

19-1996; Rev 1; 12/01

**EVALUATION KIT
AVAILABLE**

MAXIM

+3.3V, 2.488Gbps, SDH/SONET 1:16 Deserializer with Clock Recovery

General Description

The MAX3881 deserializer with clock recovery is ideal for converting 2.488Gbps serial data to 16-bit-wide, 155Mbps parallel data for SDH/SONET applications. Operating from a single +3.3V supply, this device accepts high-speed serial-data inputs and delivers single-ended PECL parallel data outputs and a differential PECL parallel clock output for interfacing with digital circuitry.

The MAX3881 includes a low-power clock recovery and data retiming function for 2.488Gbps applications. The fully integrated phase-locked loop (PLL) recovers a synchronous clock signal from the serial NRZ data input; the signal is then retimed by the recovered clock. The MAX3881's jitter performance exceeds all SDH/SONET specifications. An additional 2.488Gbps serial input is available for system loopback diagnostic testing. The device also includes a TTL-compatible loss-of-lock (LOL) monitor.

The MAX3881 is available in the extended temperature range (-40°C to +85°C) in a 64-pin TQFP-EP package.

Applications

2.488Gbps SDH/SONET Transmission Systems
Add/Drop Multiplexers
Digital Cross-Connects

Typical Application Circuit appears at end of data sheet.

Features

- ◆ Single +3.3V Supply
- ◆ 530mW Operating Power
- ◆ Fully Integrated Clock Recovery and Data Retiming
- ◆ Exceeds ANSI, ITU, and Bellcore Specifications
- ◆ Additional High-Speed Input Facilitates System Loopback Diagnostic Testing
- ◆ 2.488Gbps Serial to 155Mbps Parallel Conversion
- ◆ Differential PECL Clock Output
- ◆ Single-Ended PECL Data Outputs
- ◆ Tolerates >2000 Consecutive Identical Digits
- ◆ Loss-of-Lock Indicator

Ordering Information

PART	TEMP. RANGE	PIN-PACKAGE
MAX3881ECB	-40°C to +85°C	64 TQFP-EP*

*Exposed pad

Pin Configuration

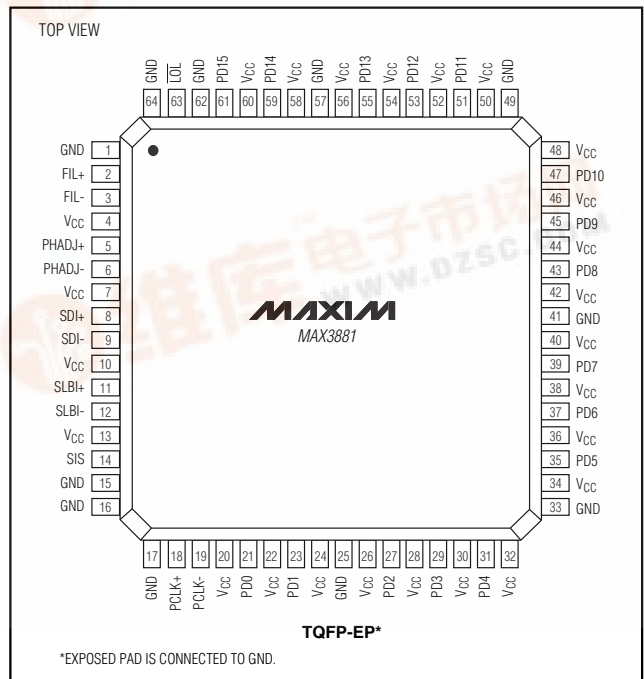

MAX3881

+3.3V, 2.488Gbps, SDH/SONET 1:16 Deserializer with Clock Recovery

ABSOLUTE MAXIMUM RATINGS

Positive Supply Voltage (V _{CC})	-0.5V to +7.0V
Input Voltage Level (SDI+, SDI-, SLBI+, SLBI-)	(V _{CC} - 0.5V) to (V _{CC} + 0.5V)
Input Current Level (SDI+, SDI-, SLBI+, SLBI-).....	±10mA
Voltage at LOL, SIS, PHADJ+, PHADJ-, FIL+, FIL-	-0.5V to (V _{CC} + 0.5V)
PECL Output Current	50mA

Continuous Power Dissipation (T _A = +85°C) 64-Pin TQFP (derate 33.3mW/°C above +85°C).....	1.44W
Operating Temperature Range	-40°C to +85°C
Storage Temperature Range	-55°C to +150°C
Lead Temperature (soldering, 10s)	+300°C

Stresses beyond those listed under "Absolute Maximum Ratings" may cause permanent damage to the device. These are stress ratings only, and functional operation of the device at these or any other conditions beyond those indicated in the operational sections of the specifications is not implied. Exposure to absolute maximum rating conditions for extended periods may affect device reliability.

DC ELECTRICAL CHARACTERISTICS

(V_{CC} = +3.0V to +3.6V, PECL loads = 50Ω to (V_{CC} - 2V), T_A = -40°C to +85°C, unless otherwise noted. Typical values are at V_{CC} = +3.3V, T_A = +25°C.)

PARAMETER	SYMBOL	CONDITIONS	MIN	TYP	MAX	UNITS
Supply Current	I _{CC}	Excluding PECL outputs		160	240	mA
SERIAL DATA INPUTS (SDI±, SLBI±)						
Differential Input Voltage	V _{ID}	Figure 1	50		800	mVp-p
Single-Ended Input Voltage	V _{IS}		V _{CC} - 0.4		V _{CC} + 0.2	V
Input Termination to V _{CC}	R _{IN}	Figure 2		50		Ω
PECL OUTPUTS (PD_, PCLK±)						
PECL Output High Voltage	V _{OH}	T _A = 0°C to +85°C	V _{CC} - 1.025		V _{CC} - 0.88	V
		T _A = -40°C to 0°C	V _{CC} - 1.085		V _{CC} - 0.88	
PECL Output Low Voltage	V _{OL}	T _A = 0°C to +85°C	V _{CC} - 1.81		V _{CC} - 1.62	V
		T _A = -40°C to 0°C	V _{CC} - 1.83		V _{CC} - 1.555	
TTL INPUTS AND OUTPUTS (SIS, LOL)						
Input High Voltage	V _{IH}		2.0			V
Input Low Voltage	V _{IL}				0.8	V
Input Current			-10		+10	μA
Output High Voltage	V _{OH}	I _{OH} ≤ 40μA	2.4		V _{CC}	V
Output Low Voltage	V _{OL}	I _{OL} ≤ 1mA			0.4	V

+3.3V, 2.488Gbps, SDH/SONET 1:16 Deserializer with Clock Recovery

AC ELECTRICAL CHARACTERISTICS

(V_{CC} = +3.0V to +3.6V, PECL loads = 50Ω to (V_{CC} - 2V), T_A = -40°C to +85°C, unless otherwise noted. Typical values are at V_{CC} = +3.3V, T_A = +25°C.) (Note 1)

PARAMETER	SYMBOL	CONDITIONS	MIN	TYP	MAX	UNITS
Serial Data Rate	SDI			2.488		Gbps
Parallel Output Data Rate				155.52		Mbps
Parallel Clock-to-Data Output Delay	t _{CLK-Q}	Figure 2	200	450	900	ps
Jitter Tolerance		f = 70kHz (Note 2)	2.31	3.3		UIp-p
		f = 100kHz	1.74	2.41		
		f = 1MHz	0.38	0.57		
		f = 10MHz	0.28	0.46		
Tolerated Consecutive Identical Digits				>2,000		Bits
Input Return Loss (SDI±, SLBI±)		100kHz to 2.5GHz		-18		dB
		2.5GHz to 4.0GHz		-11		
Output Edge Speed	t _R , t _F	20% to 80%		800		ps

Note 1: AC characteristics are guaranteed by design and characterization.

Note 2: At jitter frequencies <70kHz, the jitter tolerance of the MAX3881 outperforms the ITU/Bellcore specifications.

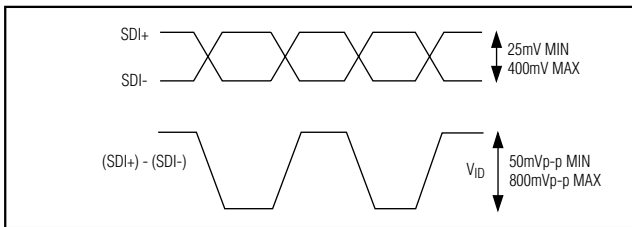

Figure 1. Input Amplitude

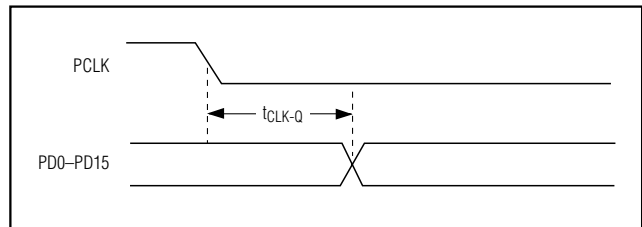

Figure 2. Timing Parameters

+3.3V, 2.488Gbps, SDH/SONET 1:16 Deserializer with Clock Recovery

Typical Operating Characteristics

(V_{CC} = +3.3V, T_A = +25°C, unless otherwise noted.)

RECOVERED DATA AND CLOCK

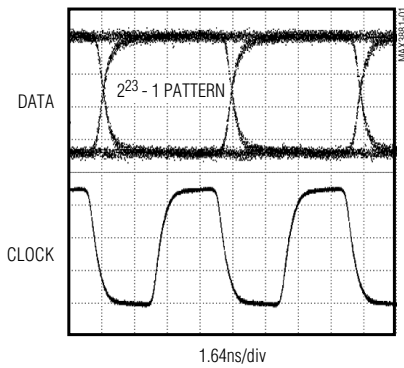

SUPPLY CURRENT vs. TEMPERATURE

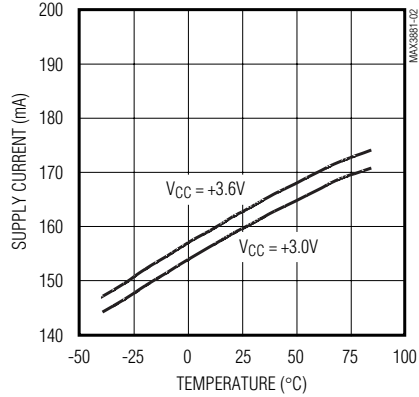

JITTER TOLERANCE

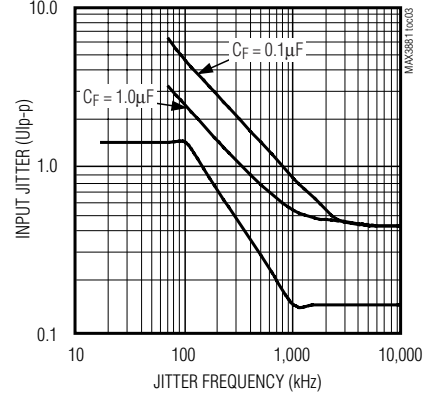

JITTER TOLERANCE vs. INPUT VOLTAGE

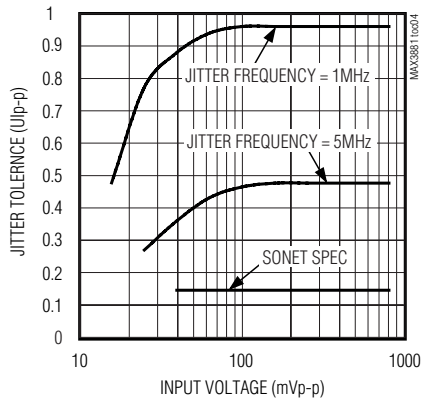

BIT ERROR RATIO vs. INPUT VOLTAGE

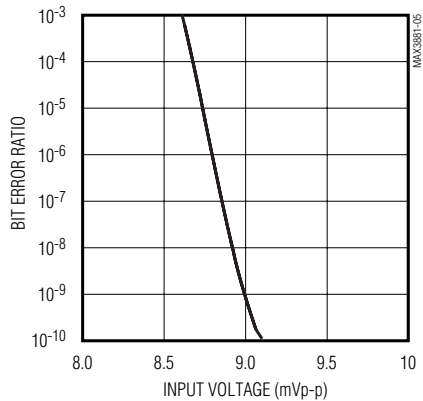

PARALLEL CLOCK TO DATA OUTPUT PROPAGATION DELAY vs. TEMPERATURE

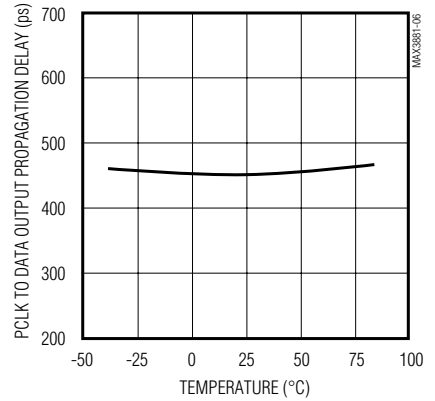

+3.3V, 2.488Gbps, SDH/SONET 1:16 Deserializer with Clock Recovery

Pin Description

MAX3881

PIN	NAME	FUNCTION
1, 15, 16, 17, 25, 33, 41, 49, 57, 62, 64	GND	Ground
2	FIL+	Positive Filter Input. PLL loop filter connection. Connect a 1.0 μ F capacitor between FIL+ and FIL-.
3	FIL-	Negative Filter Input. PLL loop filter connection. Connect a 1.0 μ F capacitor between FIL+ and FIL-.
4, 7, 10, 13, 20, 22, 24, 26, 28, 30, 32, 34, 36, 38, 40, 42, 44, 46, 48, 50, 52, 54, 56, 58, 60	VCC	+3.3V Supply Voltage
5	PHADJ+	Positive Phase-Adjust Input. Used to optimally align internal PLL phase. Connect to VCC if not used.
6	PHADJ-	Negative Phase-Adjust Input. Used to optimally align internal PLL phase. Connect to VCC if not used.
8	SDI+	Positive Serial Data Input. 2.488Gbps data stream.
9	SDI-	Negative Serial Data Input. 2.488Gbps data stream.
11	SLBI+	Positive System Loopback Input. 2.488Gbps data stream.
12	SLBI-	Negative System Loopback Input. 2.488Gbps data stream.
14	SIS	Signal Input Selection. TTL low for normal data input (SDI). TTL high for system loopback input (SLBI).
18	PCLK+	Positive Parallel Clock PECL Output
19	PCLK-	Negative Parallel Clock PECL Output
21, 23, 27, 29, 31, 35, 37, 39, 43, 45, 47, 51, 53, 55, 59, 61	PD0 to PD15	Parallel Data Single-Ended PECL Outputs. Data is updated on the negative transition of the PCLK signal (Figure 2).
63	$\overline{\text{LOL}}$	Loss-of-Lock Output. PLL loss-of-lock monitor, TTL active low (internal 10k Ω pullup resistor). The $\overline{\text{LOL}}$ monitor is valid only when a data stream is present on the inputs to the MAX3881.
EP	Exposed Pad	Ground. This must be soldered to a circuit board for proper electrical and thermal performance (see <i>Package Information</i>).

+3.3V, 2.488Gbps, SDH/SONET 1:16 Deserializer with Clock Recovery

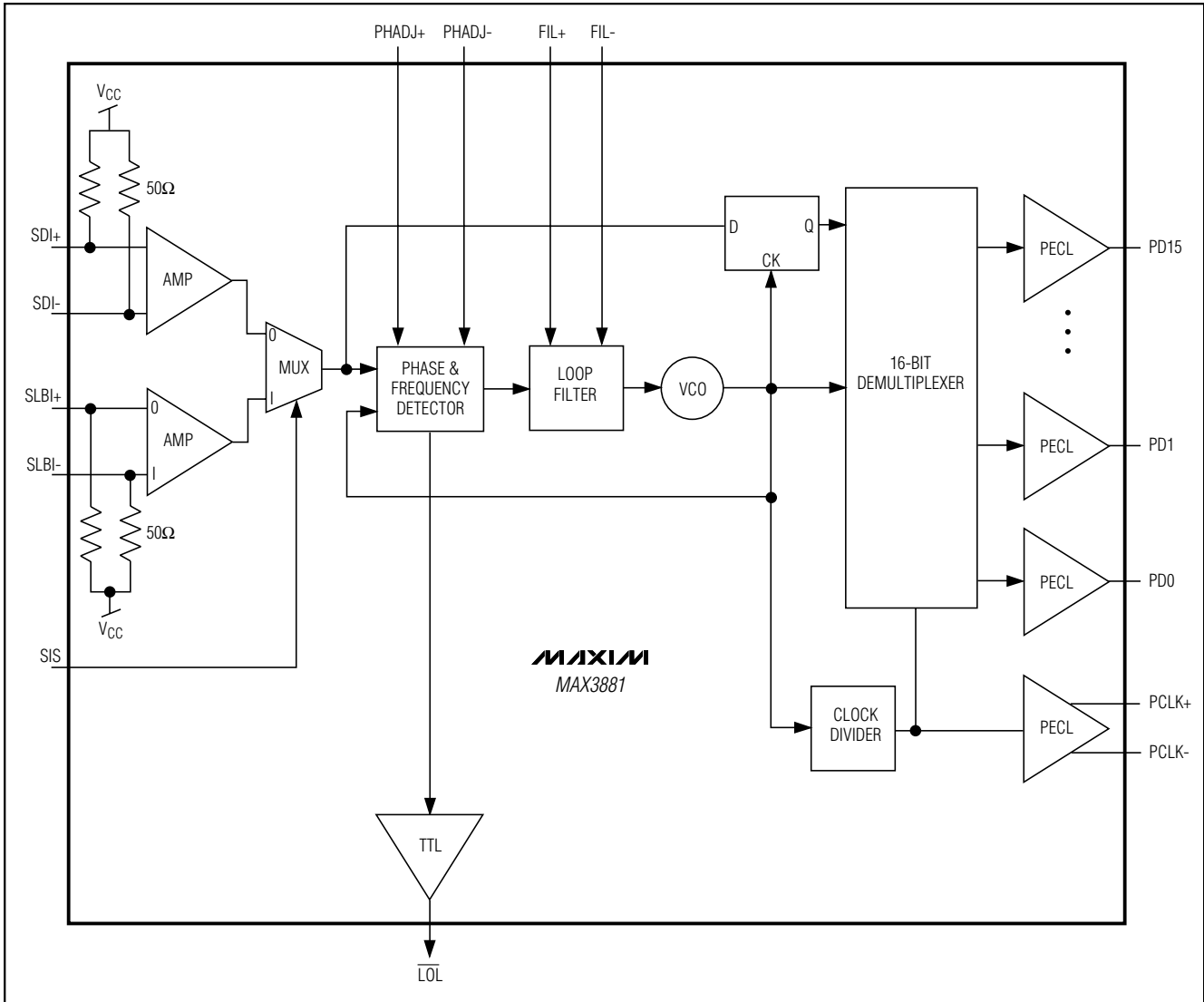

Figure 3. MAX3881 Functional Diagram

Detailed Description

The MAX3881 deserializer with clock recovery converts 2.488Gbps serial data to 16-bit-wide, 155Mbps parallel data. The device combines a fully integrated phase-locked loop (PLL), input amplifier, data retiming block, 16-bit demultiplexer, clock divider, and PECL output buffer (Figure 3). The PLL consists of a phase/frequency detector (PFD), a loop filter, and a voltage-controlled oscillator (VCO). The MAX3881 is designed to deliver the best combination of jitter performance and power

dissipation by using a differential signal architecture and low-noise design techniques. The PLL recovers the serial clock from the serial input data stream. The demultiplexer generates a 16-bit-wide 155Mbps parallel data output.

Input Amplifier

The input amplifiers on both the main data and system loopback accept a differential input amplitude from 50mVp-p to 800mVp-p. The bit error ratio (BER) is better than 1×10^{-10} for input signals as small as 9.5mVp-p,

+3.3V, 2.488Gbps, SDH/SONET 1:16 Deserializer with Clock Recovery

although the jitter tolerance performance will be degraded. For interfacing with PECL signal levels, see *Applications Information*.

Phase Detector

The phase detector in the MAX3881 produces a voltage proportional to the phase difference between the incoming data and the internal clock. Because of its feedback nature, the PLL drives the error voltage to zero, aligning the recovered clock to the center of the incoming data eye for retiming. The external phase adjust pins (PHADJ+, PHADJ-) allow the user to vary the internal phase alignment.

Frequency Detector

The digital frequency detector (FD) aids frequency acquisition during start-up conditions. The frequency difference between the received data and the VCO clock is derived by sampling the in-phase and quadrature VCO outputs on both edges of the data input signal. Depending on the polarity of the frequency difference, the FD drives the VCO until the frequency difference is reduced to zero. Once frequency acquisition is complete, the FD returns to a neutral state. False locking is completely eliminated by this digital frequency detector.

Loop Filter and VCO

The phase detector and frequency detector outputs are summed into the loop filter. A 1.0 μ F capacitor, C_F , is required to set the PLL damping ratio.

The loop filter output controls the on-chip LC VCO running at 2.488GHz. The VCO provides low phase noise and is trimmed to the correct frequency.

Loss-of-Lock Monitor

A loss-of-lock ($\overline{\text{LOL}}$) monitor is included in the MAX3881 frequency detector. A loss-of-lock condition is signaled with a TTL low. When the PLL is frequency-locked, $\overline{\text{LOL}}$ switches to TTL high in approximately 800ns.

Note that the $\overline{\text{LOL}}$ monitor is only valid when a data stream is present on the inputs to the MAX3881. As a result, $\overline{\text{LOL}}$ does not detect a loss-of-power condition resulting from a loss of the incoming signal.

Positive Emitter-Coupled Logic (PECL) Outputs

The MAX3881 features PECL outputs for the parallel clock and data outputs. For proper operation, PECL outputs should be terminated with 50 Ω to ($V_{CC} - 2V$). In many cases, it is not feasible to use the 50 Ω to ($V_{CC} - 2V$) termination, so it may be preferable to terminate to the Thévenin equivalent. See application note HFAN-1,

Interfacing Between CML, PECL, and LVDS for more details regarding the Thévenin-equivalent PECL termination.

Design Procedure

Jitter Tolerance and Input Sensitivity Trade-Offs

When the received data amplitude is higher than 50mVp-p, the MAX3881 provides a typical jitter tolerance of 0.46UIp-p at jitter frequencies greater than 10MHz. The SDH/SONET jitter tolerance specification is 0.15UIp-p, leaving a jitter allowance of 0.31UIp-p for receiver preamplifier and postamplifier design.

The BER is better than 1×10^{-10} for input signals greater than 9.5mVp-p. At 25mVp-p, jitter tolerance will be degraded, but will still be above the SDH/SONET requirement. Trade-offs can be made between jitter tolerance and input voltage according to the specific application. See the *Typical Operating Characteristics* for Jitter Tolerance and BER vs. Input Voltage graphs.

Applications Information

Consecutive Identical Digits (CIDs)

The MAX3881 has a low phase and frequency drift in the absence of data transitions. As a result, long runs of consecutive zeros and ones can be tolerated while maintaining a BER of 1×10^{-10} . The CID tolerance is tested using a $2^{13} - 1$ pseudorandom bit stream (PRBS), substituting a long run of zeros to simulate the worst case. A CID tolerance of greater than 2,000 bits is typical.

Phase Adjust

The internal clock is aligned to the center of the data eye. For specific applications, this sampling position can be shifted using the PHADJ inputs to optimize BER performance. The PHADJ inputs operate with differential input voltages up to $\pm 1.5V$. A simple resistor-divider with a bypass capacitor is sufficient to set these levels (Figure 4). When the PHADJ inputs are not used, they should be tied directly to V_{CC} .

System Loopback

The MAX3881 is designed to allow system loopback testing. The user can connect a serializer output (MAX3891) in a transceiver directly to the SLBI+ and SLBI- inputs of the MAX3881 for system diagnostics. To select the SLBI \pm inputs, apply a TTL logic high to the SIS pin.

Interfacing with PECL Input Levels

When interfacing with differential PECL input levels, it is important to attenuate the signal while still maintaining

+3.3V, 2.488Gbps, SDH/SONET 1:16 Deserializer with Clock Recovery

50Ω termination (Figure 5). AC-coupling is also required to maintain the input common-mode level.

Exposed-Pad Package

The exposed-pad (EP), 64-pin TQFP incorporates features that provide a very low thermal-resistance path for heat removal from the IC. The pad is electrical ground on the MAX3881 and must be soldered to the circuit board for proper thermal and electrical performance.

Layout Techniques

For best performance, use good high-frequency layout techniques. Filter voltage supplies, keep ground connections short, and use multiple vias where possible. Use controlled-impedance transmission lines to interface with the MAX3881 high-speed inputs and outputs. Power-supply decoupling should be placed as close to VCC pins as possible. To reduce feedthrough, take care to isolate the input signals from the output signals.

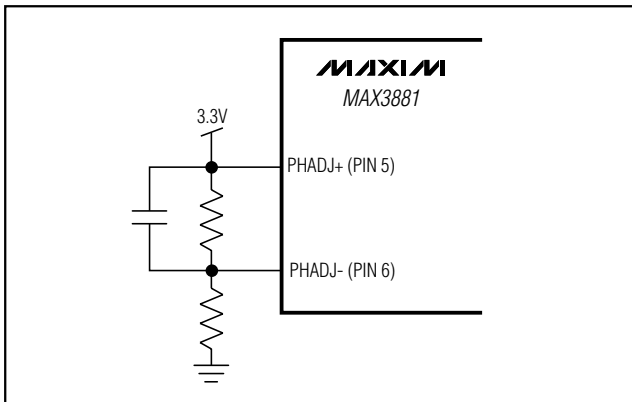

Figure 4. Phase-Adjust Resistor-Divider

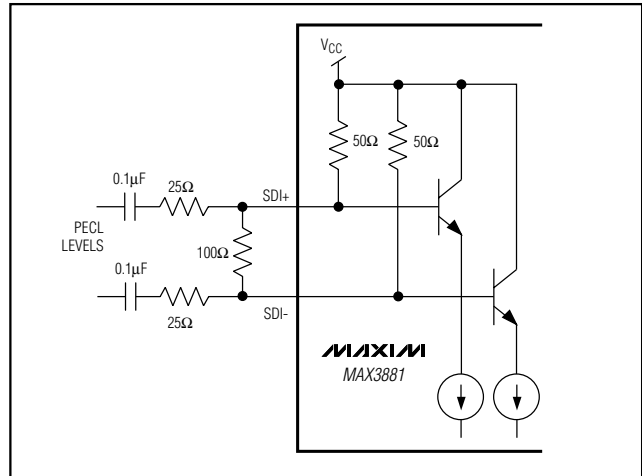

Figure 5. Interfacing with PECL Input Levels

Chip Information

TRANSISTOR COUNT: 2231
PROCESS: BiPolar

+3.3V, 2.488Gbps, SDH/SONET 1:16 Deserializer with Clock Recovery

Package Information

64L, TQFP.EPS

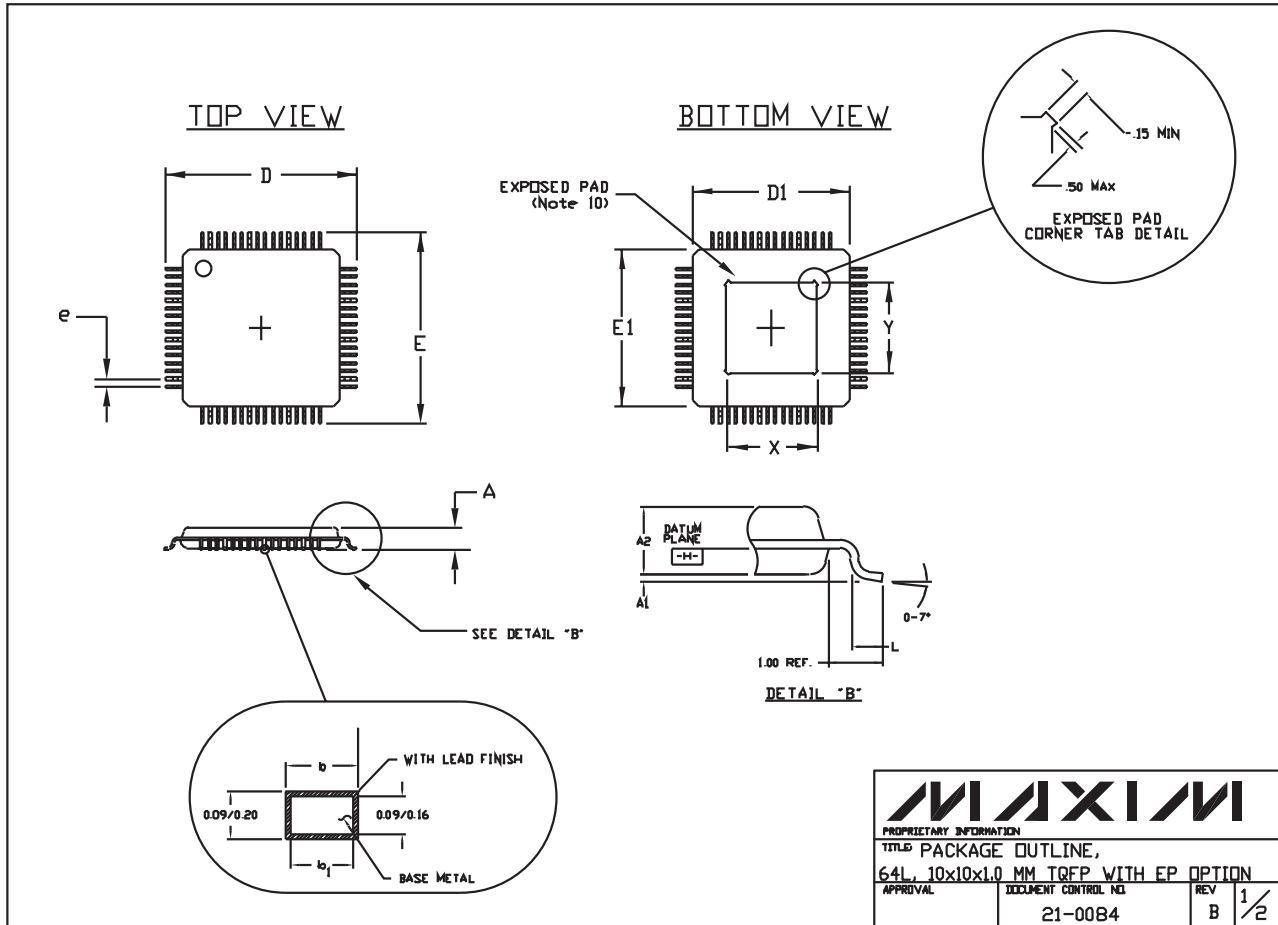

+3.3V, 2.488Gbps, SDH/SONET 1:16 Deserializer with Clock Recovery

Package Information (continued)

MAX3881

NOTES:

1. ALL DIMENSIONS AND TOLERANCING CONFORM TO ANSI Y14.5-1982.
2. DATUM PLANE -H- IS LOCATED AT MOLD PARTING LINE AND COINCIDENT WITH LEAD, WHERE LEAD EXITS PLASTIC BODY AT BOTTOM OF PARTING LINE.
3. DIMENSIONS D1 AND E1 DO NOT INCLUDE MOLD PROTRUSION. ALLOWABLE MOLD PROTRUSION IS 0.254 MM ON D1 AND E1 DIMENSIONS.
4. THE TOP OF PACKAGE IS SMALLER THAN THE BOTTOM OF PACKAGE BY 0.15 MILLIMETERS.
5. DIMENSION *b* DOES NOT INCLUDE DAMBAR PROTRUSION. ALLOWABLE DAMBAR PROTRUSION SHALL BE 0.08 MM TOTAL IN EXCESS OF THE *b* DIMENSION AT MAXIMUM MATERIAL CONDITION.
6. CONTROLLING DIMENSION: MILLIMETER.
7. THIS OUTLINE CONFORMS TO JEDEC PUBLICATION 95 REGISTRATION MO-136, VARIATION AJ.
8. LEADS SHALL BE COPLANAR WITHIN .004 INCH.
9. EXPOSED DIE PAD SHALL BE COPLANAR WITH BOTTOM OF PACKAGE WITHIN 2 MILS (.05 MM).
10. DIMENSIONS X & Y APPLY TO EXPOSED PAD (EP) VERSIONS ONLY. SEE INDIVIDUAL PRODUCT DATASHEET TO DETERMINE IF A PRODUCT USES EXPOSED PAD PACKAGE.

S Y M B O L	JEDEC VARIATION ALL DIMENSIONS IN MILLIMETERS	
	AJ	
	MIN.	MAX.
A	~	1.20
A1	0.05	0.15
A2	0.95	1.05
D	12.00 BSC.	
D1	10.00 BSC.	
E	12.00 BSC.	
E1	10.00 BSC.	
L	0.45	0.75
N	64	
e	0.50 BSC.	
b	0.17	0.27
b1	0.17	0.23
*X	4.7	5.30
*Y	4.70	5.30

* EXPOSED PAD
(Note 10)

			
PROPRIETARY INFORMATION			
TITLE: PACKAGE OUTLINE, 64L, 10x10x1.0 MM TQFP WITH EP OPTION			
APPROVAL	DOCUMENT CONTROL NO.	REV	2/2
	21-0084	B	

Maxim cannot assume responsibility for use of any circuitry other than circuitry entirely embodied in a Maxim product. No circuit patent licenses are implied. Maxim reserves the right to change the circuitry and specifications without notice at any time.

Maxim Integrated Products, 120 San Gabriel Drive, Sunnyvale, CA 94086 408-737-7600 _____ 11