

MAXIM

MAX3876 Evaluation Kit

Evaluates: MAX3876

General Description

The MAX3876 evaluation kit (EV kit) simplifies evaluation of the MAX3876 2.5Gbps clock-recovery and data-retiming IC. The EV kit enables testing of all MAX3876 functions. SMA connectors are provided for the differential CML data and clock outputs, as well as for system loopback functions.

The MAX3876 EV kit comes configured for +3.3V operation and consumes approximately 140mA.

Features

- ◆ SMA Connections for All System I/Os
- ◆ Test Point for Monitoring Loss-of-Lock (LOL)
- ◆ Single +3.3V Power-Supply Operation
- ◆ Fully Assembled and Tested

Component Suppliers

SUPPLIER	PHONE	FAX
Coilcraft	847-639-6400	847-639-1469

Note: Please indicate that you are using the MAX3876 when contacting this component supplier.

Ordering Information

PART	TEMP. RANGE	IC PACKAGE
MAX3876EVKIT	-40°C to +85°C	5mm 32 TQFP

Component List

DESIGNATION	QTY	DESCRIPTION
C1–C6, C14–C18, C21–C26, C29, C30	19	0.1µF, 10V min ceramic capacitors
C7–C11	5	Open
C12	1	1µF, 10V min X7R ceramic capacitor
C19	1	33µF ±20%, 10V min tantalum capacitor
C20	1	2.2µF, 10V min ceramic capacitor
D1	1	Red LED
L1, L2, L3	3	56nH inductors Coilcraft 0805HS-560TKBC
R1	1	392Ω ±1% resistor
R10, R13, R17, R21	4	Open

DESIGNATION	QTY	DESCRIPTION
R25, R28	2	0Ω ±5% resistors
LOL, GND, +3.3V	3	Test points
JP10	1	3-pin header (0.1in centers)
None	2	Shunts
SDI+, SDI-, SLBI+, SLBI-, SCLKO+, SCLKO-, SDO+, SDO-	8	Edge-mount SMA connectors
U1	1	MAX3876EHJ (5mm 32-pin TQFP)
None	1	MAX3876 evaluation kit
None	1	MAX3876 data sheet



MAX3876 Evaluation Kit

Detailed Description

The MAX3876 EV kit is fully assembled and factory tested. It enables testing of all MAX3876 functions.

Test Equipment Required

- +3.3V power supply with 300mA current capability
- Signal-source, 2.5Gbps minimum capability
- Jitter analyzer capable of 2.5Gbps performance
- Oscilloscope with at least 3GHz performance

Connections

The MAX3876 EV kit provides on-board capacitors for all data and clock I/O ports. The serial data and system loopback inputs (SDI+, SDI-, SLBI+, and SLBI-) can be connected directly to a 50Ω source. Additional pads for 50Ω pull-up resistors and 0.1μF power-supply decoupling capacitors are provided on the serial data and clock outputs (SDO+, SDO-, SCLKO+, and SCLKO-). The EV kit is shipped without 50Ω pull-up resistors and can be connected directly to standard test equipment. For evaluation with high-impedance probes, install the 50Ω pull-up resistors and 0.1μF decoupling capacitors.

Setup

- 1) Select either the serial data inputs, pins 2 and 3 of JP10 (SDI EN), or the system loopback inputs, pins 1 and 2 of JP10 (SLBI EN), with jumper JP10 (Table 1).
- 2) Connect the +3.3V power supply to the appropriate terminals marked on the EV kit, and apply power.
- 3) Connect a 2.5Gbps PRBS NRZ signal to the selected inputs with 50Ω cables.
- 4) Connect the outputs to a 50Ω high-speed oscilloscope.

Jitter analysis and product performance can also be observed by appropriately interfacing the EV kit with a bit-error-rate tester (BERT) and a jitter analyzer.

Jumpers, and Test Points

PLL frequency lock conditions can be monitored at the high-impedance $\overline{\text{LOL}}$ test point. A TTL high (LED off) indicates PLL frequency lock, while a TTL low (LED on) indicates a loss-of-lock condition. Note that the $\overline{\text{LOL}}$ circuitry will not detect a loss-of-power condition (refer to the MAX3876 data sheet).

Layout Considerations

The MAX3876's performance can be greatly affected by circuit board layout and design. Use good high-frequency design techniques, including minimizing ground inductances and using fixed-impedance transmission lines on the data and clock signals.

Table 1. Jumpers and Test Points

NAME	TYPE	DESCRIPTION	NORMAL POSITION
JP10	3-Pin	Used to select between the serial data input (labeled SDI EN) and the system loopback function (labeled SLBI EN) of the MAX3876	—
$\overline{\text{LOL}}$	Test Point	Used to monitor $\overline{\text{LOL}}$ voltage level	—

MAX3876 Evaluation Kit

Evaluates: MAX3876

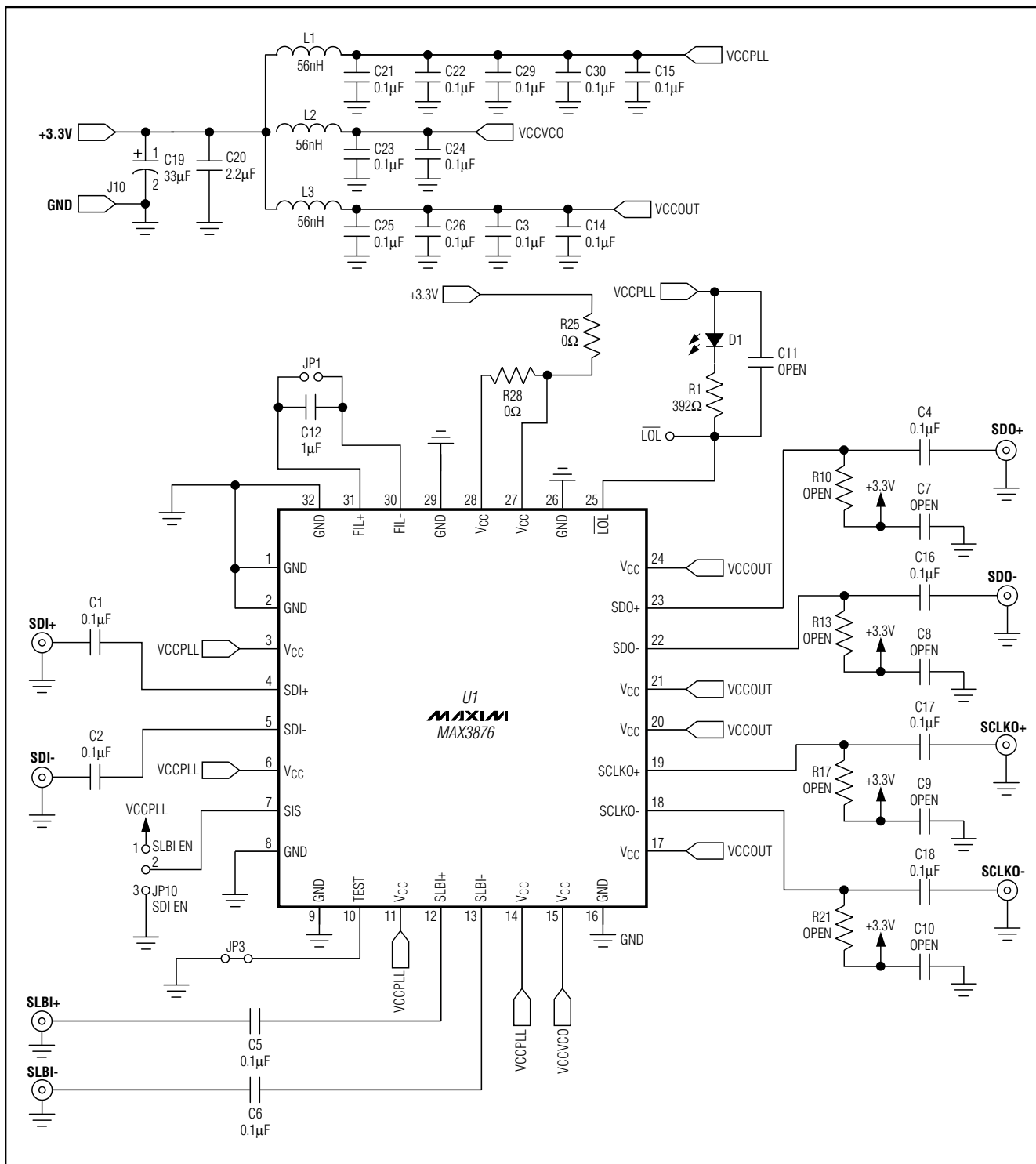

Figure 1. MAX3876 EV Kit Schematic

MAX3876 Evaluation Kit

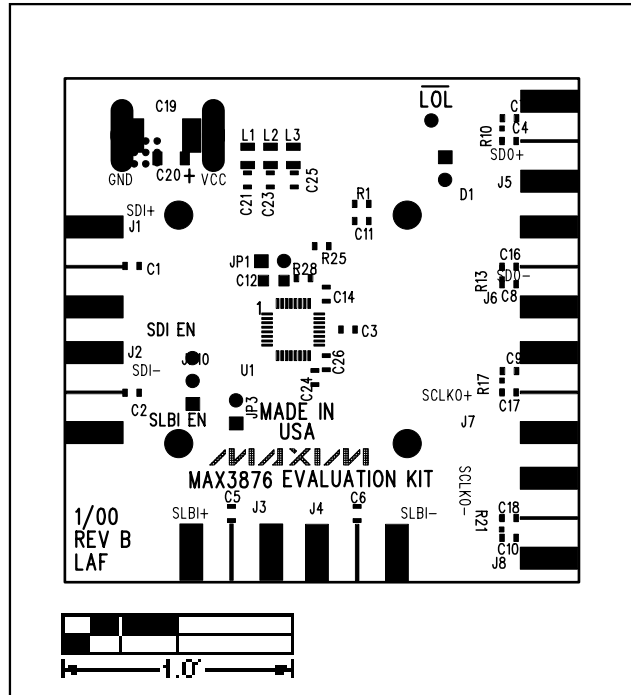

Figure 2. MAX3876 EV Kit Component Placement Guide

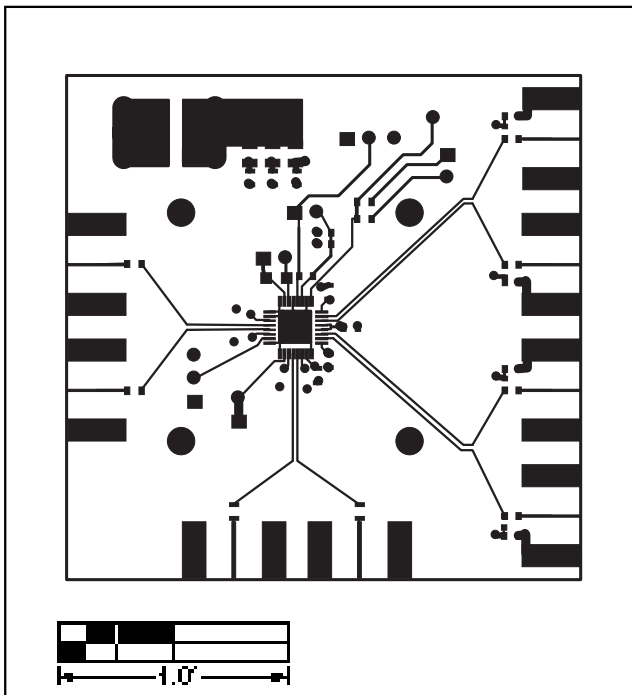

Figure 3. MAX3876 EV Kit PC Board Layout—Component Side

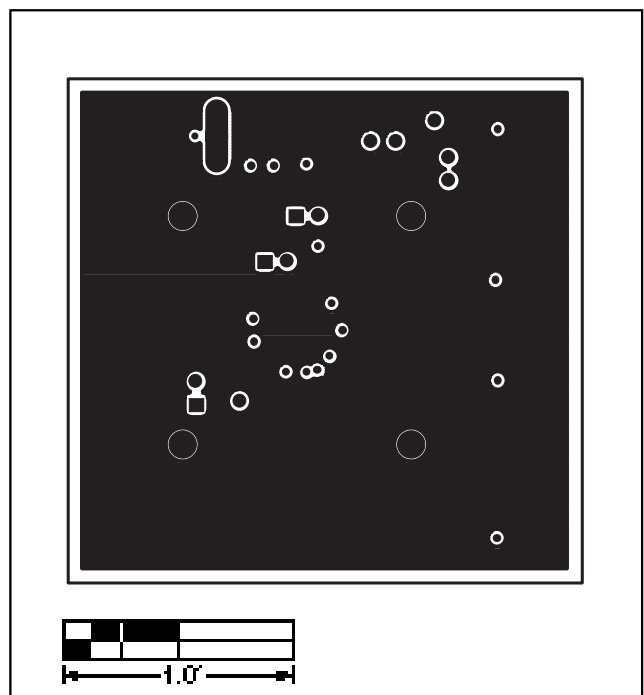

Figure 4. MAX3876 EV Kit PC Board Layout—Ground Plane

MAX3876 Evaluation Kit

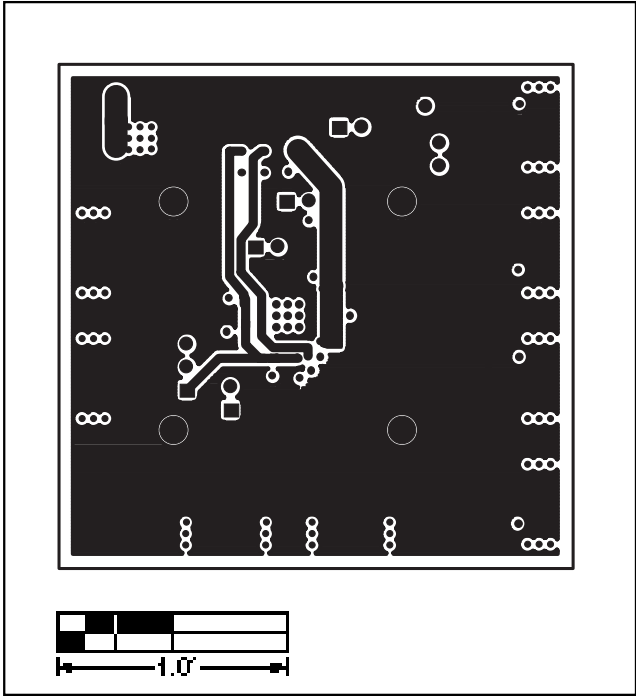

Figure 5. MAX3876 EV Kit PC Board Layout—Power Plane

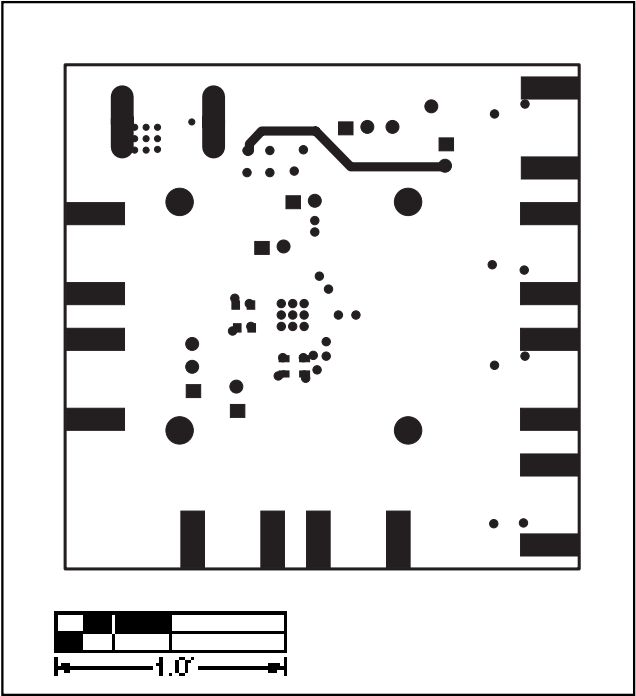

Figure 6. MAX3876 EV Kit PC Board Layout—Solder Side

Evaluates: MAX3876

Evaluates: MAX3876

MAX3876 Evaluation Kit

NOTES

Maxim cannot assume responsibility for use of any circuitry other than circuitry entirely embodied in a Maxim product. No circuit patent licenses are implied. Maxim reserves the right to change the circuitry and specifications without notice at any time.

6 _____ **Maxim Integrated Products, 120 San Gabriel Drive, Sunnyvale, CA 94086 408-737-7600**

© 2000 Maxim Integrated Products

Printed USA

MAXIM is a registered trademark of Maxim Integrated Products.