

# MAXIM

## MAX3890 Evaluation Kit

Evaluates: MAX3890

### General Description

The MAX3890 evaluation kit (EV kit) is an assembled surface-mount demonstration board that provides easy evaluation of the MAX3890 2.5Gbps 16:1 serializer with clock synthesis and low-voltage differential signal (LVDS) inputs.

### Component List

DESIGNATION	QTY	DESCRIPTION
C1–C6, C10, C11, C13, C14, C15	11	0.1 $\mu$ F $\pm$ 10%, 25V min ceramic capacitors
C7	1	0.33 $\mu$ F $\pm$ 10%, 16V min, X7R type ceramic capacitor
C8, C9, R1, R2, R23, JU6–JU9	0	Not installed
C12	1	33 $\mu$ F capacitor Sprague 593D336X9020D
J1–J6	6	SMA connectors (edge mount)
J7–J22, J24–J43	36	SMB connectors (PC mount)
J44, J45	2	SMA connectors (PC mount)
J46, J47	2	Test points
JU1–JU5	5	2-pin headers
L1–L4	4	56nH inductors Coilcraft 0805CS-560XKBC
R3	1	10k $\Omega$ $\pm$ 5% resistor
R4, R8, R12, R16	4	27 $\Omega$ $\pm$ 5% resistors
R5, R9, R13, R17	4	24 $\Omega$ $\pm$ 5% resistors
R6, R10, R14, R18	4	220 $\Omega$ $\pm$ 5% resistors
R7, R11, R15, R19	4	130 $\Omega$ $\pm$ 5% resistors
R20, R21	2	4.99k $\Omega$ $\pm$ 1% resistors
R22	1	20k $\Omega$ $\pm$ 5% resistor
U1	1	MAX3890 (64-pin TQFP-EP)
None	1	MAX3890 PC board
None	1	MAX3890 data sheet
None	3	Shunts for JU1–JU3

### Features

- ◆ +3.3V Single Supply
- ◆ Selectable Reference Clock Frequencies (155.52MHz, 77.76MHz, 51.84MHz, 38.88MHz)
- ◆ Fully Assembled and Tested Surface-Mount Board

### Ordering Information

PART	TEMP RANGE	IC PACKAGE
MAX3890EVKIT	-40°C to +85°C	64 TQFP-EP*

\*Exposed Pad

### Component Suppliers

SUPPLIER	PHONE	FAX
Coilcraft	847-639-6400	847-639-1469
Sprague	207-324-4140	603-224-1430

**Note:** Please indicate that you are using the MAX3890 when contacting these suppliers.

### Detailed Description

The MAX3890 EV kit simplifies evaluation of the MAX3890. The EV kit operates from a +3.3V single supply and includes all the external components necessary to interface with LVDS inputs and 3.3V positive-referenced emitter-coupled logic (PECL) outputs.

The LVDS inputs (PDI<sub>+</sub>, PDI<sub>-</sub>, PCLKI<sub>+</sub>, PCLKI<sub>-</sub>, RCLK<sub>+</sub>, RCLK<sub>-</sub>)\*\* are internally terminated with 100 $\Omega$  differential input resistance and therefore do not require external termination. Ensure that LVDS devices driving these inputs are not redundantly terminated. The LVDS outputs (PCLKO<sub>+</sub>, PCLKO<sub>-</sub>) require a differential termination with a 100 $\Omega$  resistor between complementary outputs. Do not terminate these outputs to ground.

### Layout Considerations

The PECL outputs have voltage attenuation (0.46) and impedance matching networks on the EV board that allow 50 $\Omega$  terminations to ground for oscilloscope interfacing. All signal inputs and outputs use coupled 50 $\Omega$  transmission lines. All input signal lines are of equal length to minimize propagation-delay skew. Likewise, all output signal lines are of equal length.

\*\*Note: PCLKO<sub>±</sub>, PCLKI<sub>±</sub>, RCLK<sub>±</sub>, and SCLK<sub>±</sub> are labeled as PCKO<sub>±</sub>, PCKI<sub>±</sub>, RCK<sub>±</sub>, and SCK<sub>±</sub> on PC board.



# MAX3890 Evaluation Kit

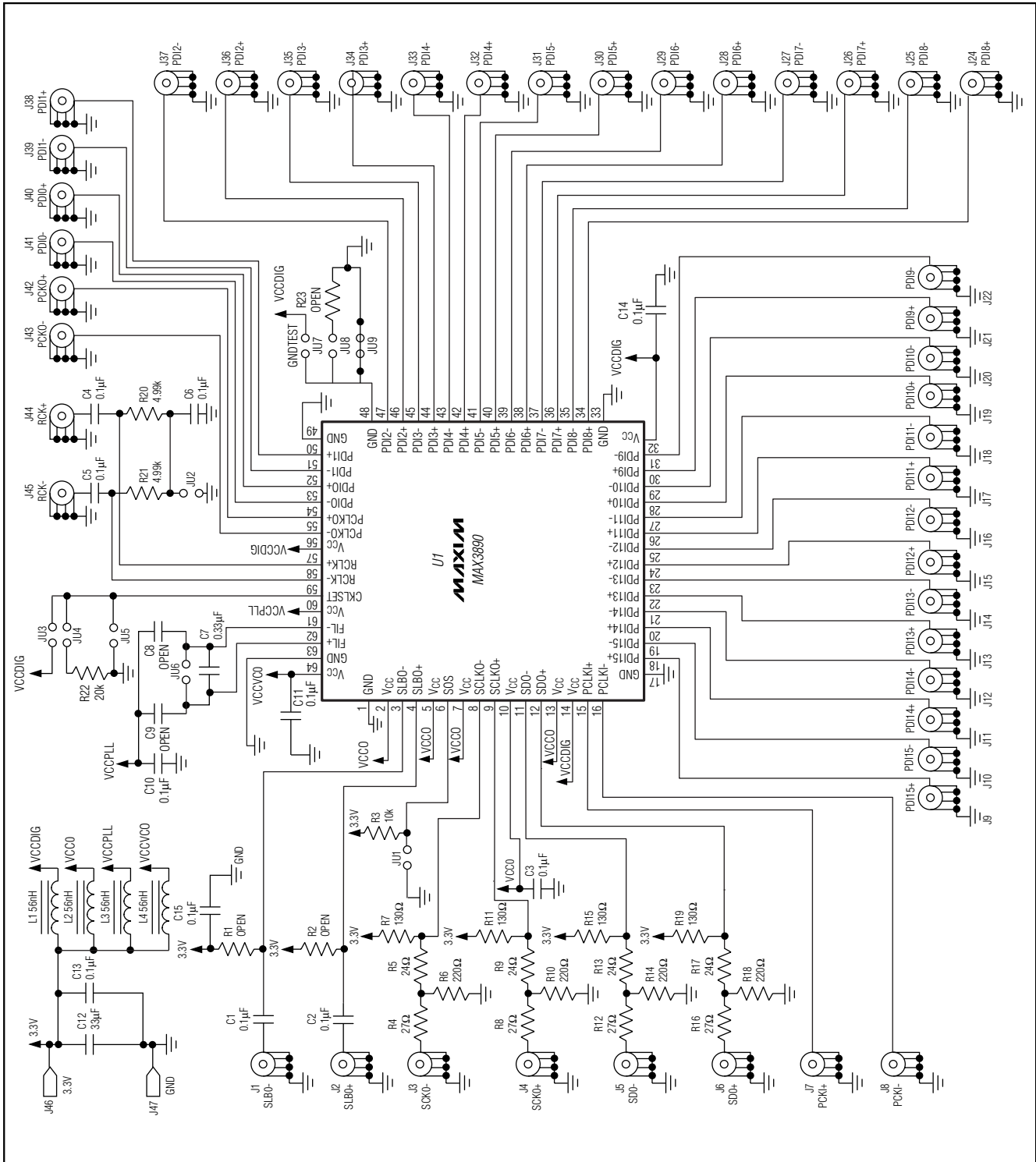

Figure 1. MAX3890 EV Kit Schematic

# MAX3890 Evaluation Kit

Evaluates: MAX3890

## Jumpers

JU1 should be shorted for normal operation and removed to enable SLBO+ and SLBO- for system loopback testing. The MAX3890 EV kit allows the use of multiple reference clock frequencies with the appropriate setting on JU3, JU4, or JU5. See Table 1 for these jumper settings.

## Exposed Pad Package

The exposed pad (EP) 64-pin TQFP incorporates features that provide a very low thermal resistance path for heat removal from the IC—either to a PC board or to an external heatsink. The MAX3890's EP must be soldered directly to a ground plane with good thermal conductance.

Table 1. CLKSET Jumper Functions

f <sub>RCLK</sub> (MHz)	JU3	JU4	JU5
155.52	Shorted (to V <sub>CC</sub> )	Open	Open
77.76	Open	Open	Open
51.84	Open	Shorted (20kΩ to ground)	Open
38.88	Open	Open	Shorted (to ground)

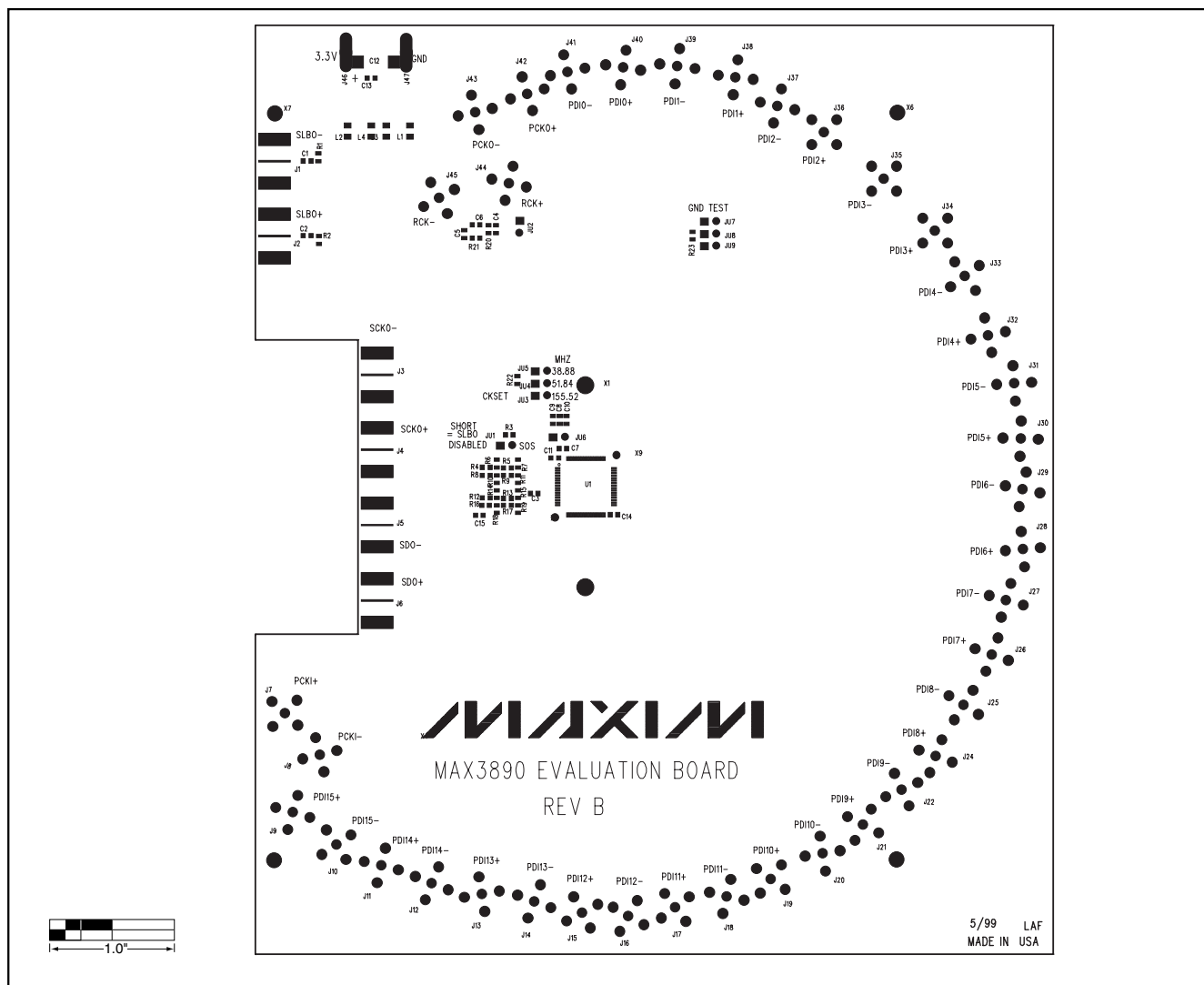

Figure 2. MAX3890 EV Kit Component Placement Guide

# MAX3890 Evaluation Kit

Evaluates: MAX3890

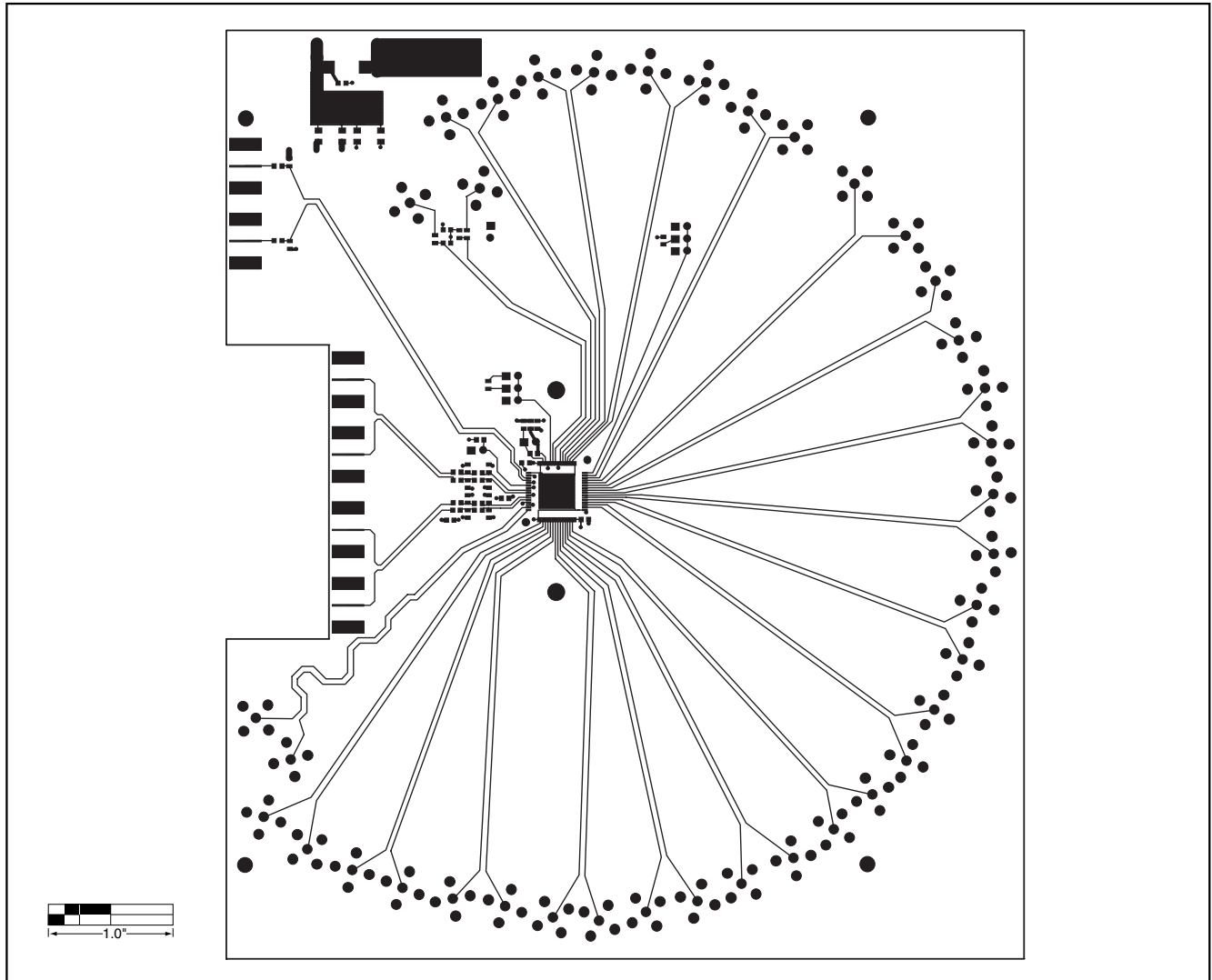

Figure 3. MAX3890 EV Kit PC Board Layout—Component Side

# MAX3890 Evaluation Kit

Evaluates: MAX3890

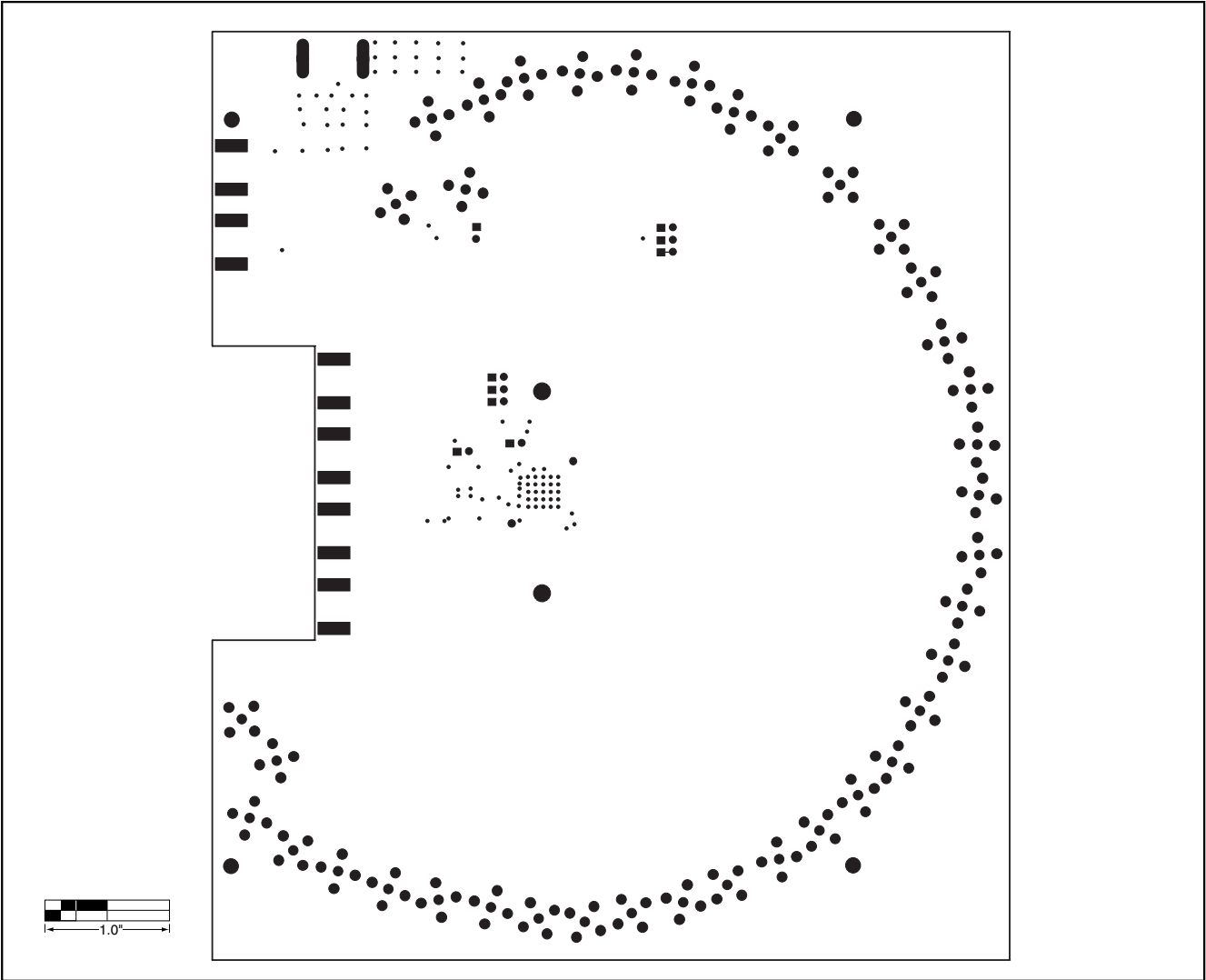

Figure 4. MAX3890 EV Kit PC Board Layout—Solder Side

# MAX3890 Evaluation Kit

Evaluates: MAX3890

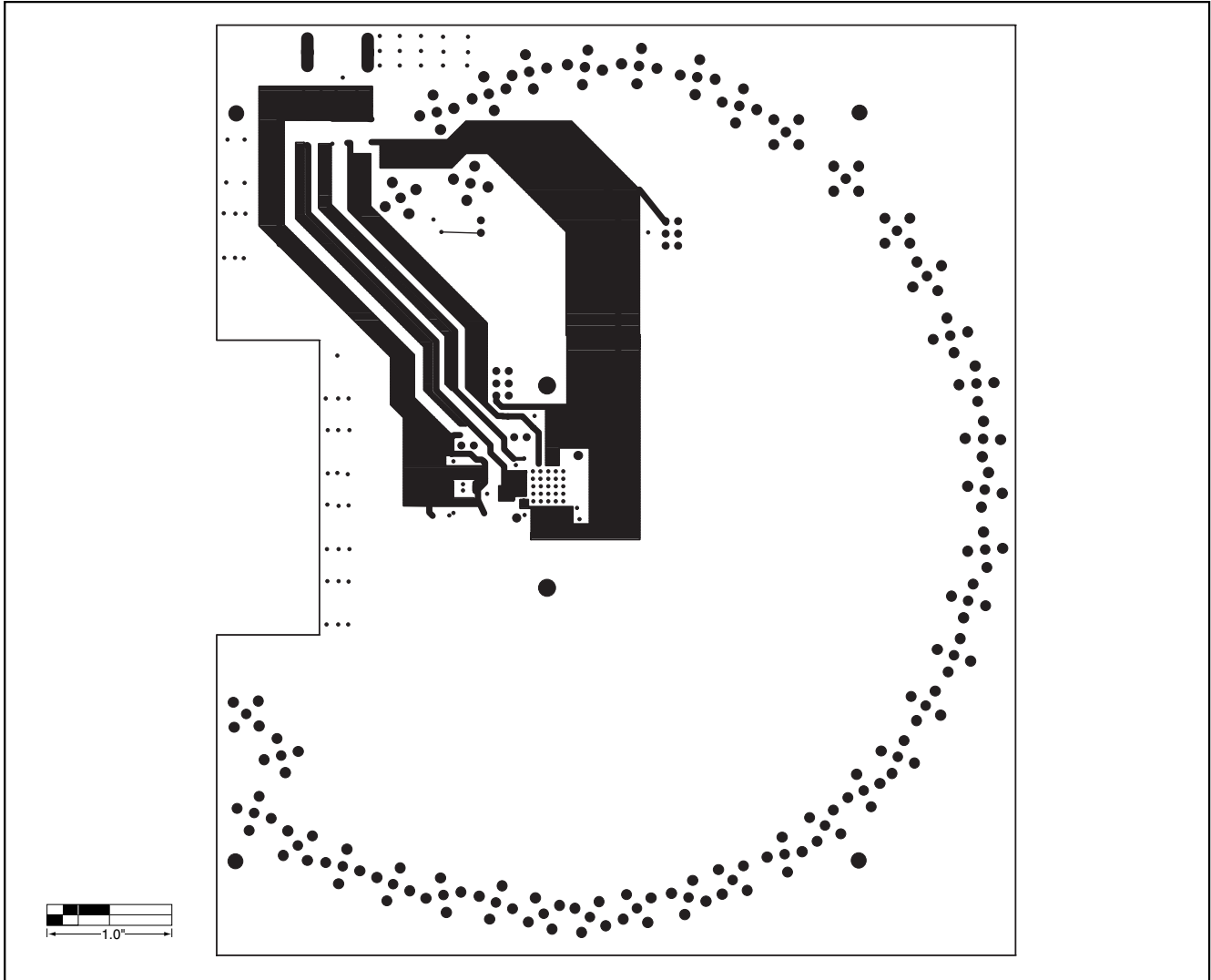

Figure 5. MAX3890 EV Kit PC Board Layout—Power Plane

# MAX3890 Evaluation Kit

Evaluates: MAX3890

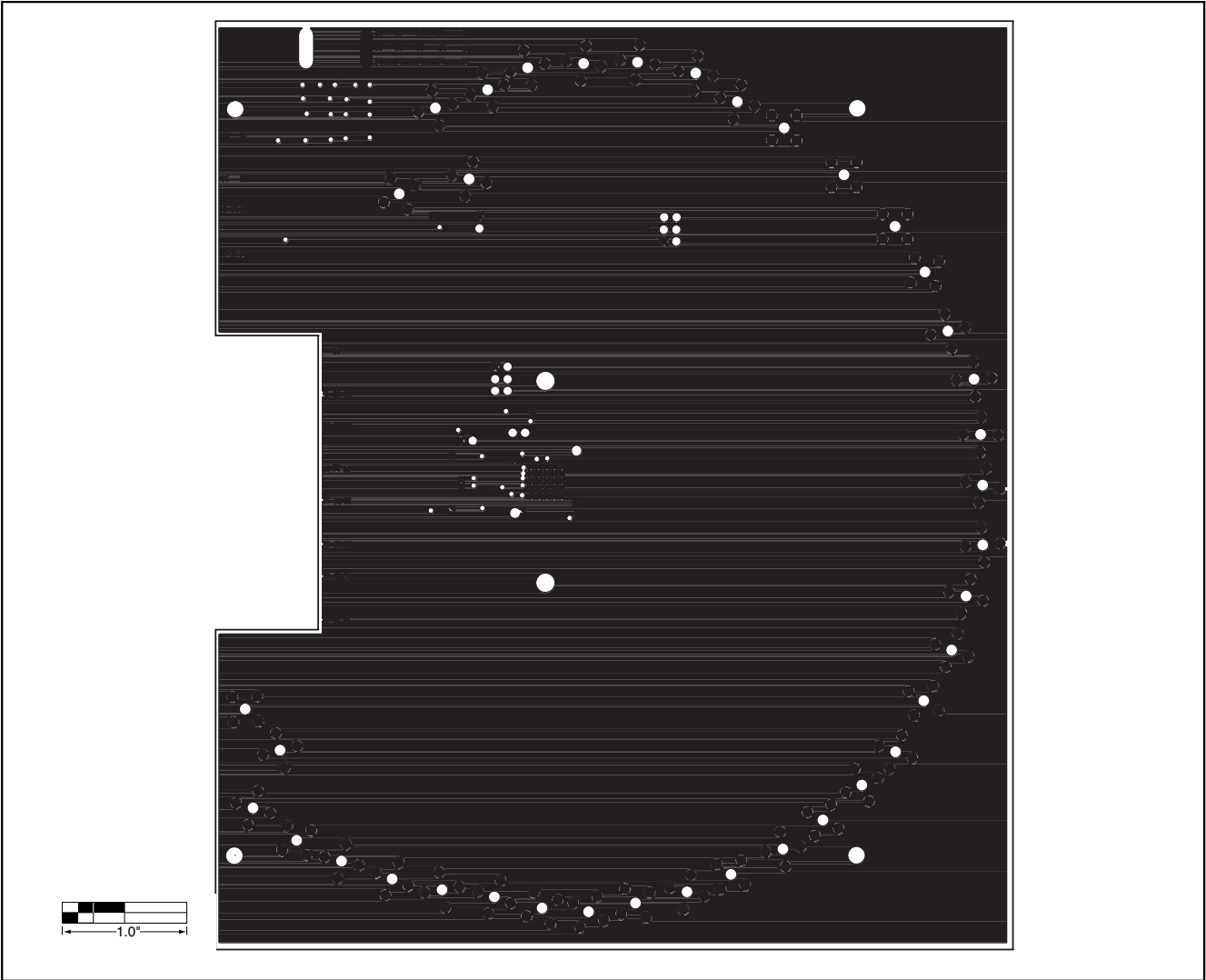

Figure 6. MAX3890 EV Kit PC Board Layout—Ground Plane

Maxim cannot assume responsibility for use of any circuitry other than circuitry entirely embodied in a Maxim product. No circuit patent licenses are implied. Maxim reserves the right to change the circuitry and specifications without notice at any time.

Maxim Integrated Products, 120 San Gabriel Drive, Sunnyvale, CA 94086 408-737-7600 \_\_\_\_\_ 7