

MAXIM

MAX1724 Evaluation Kit

General Description

The MAX1724 evaluation kit (EV kit) is a fully assembled and tested surface-mount circuit board that contains two separate boost switching-regulator circuits. The left-side circuit contains a MAX1724 with a preset 3.3V output. Other preset voltages of 2.7V, 3.0V, or 5.0V are also available. The right-side circuit contains a MAX1722, which has an adjustable output voltage. This circuit's output is set for 3.6V. All devices regulate with input voltages from 0.91V to V_{OUT}, making them ideal for 1- or 2-cell alkaline and NiMH battery applications.

The right-side circuit may also be used to evaluate the MAX1723, which features a shutdown (SHDN) mode. The MAX1722/MAX1724 has a BATT pin, which lowers the guaranteed startup voltage from 1.2V to 0.91V.

The MAX1722/MAX1723/MAX1724 feature synchronous rectification and ultra-low (1.5µA typ) quiescent current for maximum efficiency and long battery life. Operation up to 200kHz allows tiny surface-mount components.

Component List

DESIGNATION	QTY	DESCRIPTION
C1-C4	4	10µF, 10V X7R ceramic capacitors Taiyo Yuden JMK325BJ106MN
D1	0	Not installed
L1, L2	2	10µH inductors Sumida CDR43-100MC
R1	1	2MΩ ±1% resistor (0805) Venkel CR0805-10W-2004FT
R2	1	1.02MΩ ±1% resistor (0805) Venkel CR0805-10W-1024FT
U1	1	Maxim MAX1724EZK33 (5-pin THIN SOT23, top mark ADQJ)
U2	1	Maxim MAX1722EZK (5-pin THIN SOT23, top mark ADQF)
JU1, JU2	2	3-pin headers
None	2	Shunts JU1, JU2
None	1	MAX1724 PC board
None	1	MAX1722/MAX1723/MAX1724 data sheet
None	1	MAX1724 EV kit data sheet

Note: Quantities are for both circuits.

Features

- ◆ 0.91V to V_{OUT} Input Voltage Range
- ◆ Two Complete Boost Circuits
 - 3.3V Fixed (MAX1724)
 - 3.6V Adjustable Output (MAX1722)
- ◆ Up to 50mA Output from a 1-Cell Input
Up to 100mA Output from a 2-Cell Input
- ◆ 1.5µA Quiescent Current from V_{OUT}
- ◆ Up to 90% Efficiency with Synchronous Rectification
- ◆ Switching Frequency Up to 200kHz
- ◆ All Surface-Mount Design
- ◆ Fully Assembled and Tested Board

Ordering Information

PART	TEMP. RANGE	IC PACKAGE
MAX1724EVKIT	0°C to +70°C	THIN SOT23-5

Component Suppliers

SUPPLIER	PHONE	FAX	WEB
Murata	814-237-1431	814-238-0490	www.murata.com
Sumida	847-956-0666	847-956-0702	www.sumida.com
Taiyo Yuden	408-573-4150	408-573-4159	www.T-yuden.com
Venkel	512-794-0081	512-794-0087	www.venkel.com

Note: Please indicate that you are using the MAX1724 when contacting these component suppliers.

Quick Start

The MAX1724 EV kit is fully assembled and tested. Follow these steps to verify board operation. **Do not turn on the power supply until all connections are completed.**

3.3V Output (left side):

- 1) Connect a 0.91V to 3.3V supply to the VBATT pad. Connect the supply ground to the GND pad.
- 2) Connect a voltmeter to the V_{OUT} pad.
- 3) Verify there is a shunt across pins 1 and 2 of jumper JU1 (SHDN), thus enabling the MAX1724.
- 4) Turn on the power supply and verify that the output is at 3.3V.

Evaluates: MAX1722/MAX1723/MAX1724



MAX1724 Evaluation Kit

3.6V Output (right side):

- 1) Connect a 0.91V to 3.6V supply to the VBATT pad. Connect the supply ground to the GND pad.
- 2) Connect a voltmeter to the VOUT pad.
- 3) Verify there is a shunt across pins 1 and 2 of jumper JU2 to connect BATT to VBATT for the MAX1722.
- 4) Turn on the power supply and verify that the output is at 3.6V.

For instructions on selecting feedback resistors for other output voltages, see *Evaluating Other Output Voltages (Right Side)*.

Detailed Description

The MAX1724 EV kit contains two separate boost switching-regulator circuits. The left-side circuit (MAX1724) supplies a preset 3.3V output. The right-side circuit (MAX1722) supplies an adjustable 3.6V output, but can also be set from 2.0V to 5.5V. Both circuits regulate with input voltages from 0.91V to V_{OUT} , but can accept higher input voltages (below 5.5V) if it is acceptable for the output voltage to rise above the set V_{OUT} . Output current for both circuits is 50mA with a 1.2V input, and 100mA for a 2.4V input.

The 3.6V output voltage (right side) can also be adjusted from 2.0V to 5.5V using external resistors R1 and R2. The input voltage ranges from 0.91V to (V_{OUT}) when operating from a DC source.

The MAX1724 boost converter (left side) features a 0.1 μ A shutdown mode.

Jumper Selection MAX1724 Circuit (Left Side)

The MAX1724 EV kit's shutdown mode reduces the IC's quiescent current to 0.1 μ A (typ), preserving battery life. Jumper JU1 selects the shutdown mode for the MAX1724. Table 1 lists the MAX1724 jumper options.

Table 1. MAX1724 Jumper JU1 Functions

SHUNT LOCATION	SHDN PIN	MAX1724 OUTPUT
1-2	Connected to VBATT	MAX1724 enabled, $V_{OUT} = 3.3V$
2-3	Connected to GND	Shutdown mode, $V_{OUT} = V_{BATT} - V_{DIODE}$

MAX1722 Circuit (Right Side)

When jumper JU2 on the right-side circuit is used with a MAX1722, pins 1 and 2 must be connected together so that BATT is connected to the battery input (VBATT). When the right-side circuit is used to evaluate a MAX1723, see *Evaluating the MAX1723* section. Table 2 lists the MAX1722 jumper options.

Table 2. MAX1722 Jumper JU2 Functions

SHUNT LOCATION	BATT PIN
1-2	Connected to VBATT
2-3	Not allowed

3.6V Output (right side):

- 1) Connect a 0.91V to 3.6V supply to the VBATT pad. Connect the supply ground to the GND pad.
- 2) Connect a voltmeter to the VOUT pad.
- 3) Verify there is a shunt across pins 1 and 2 of jumper JU2 to connect BATT to VBATT for the MAX1722.
- 4) Turn on the power supply and verify that the output is at 3.6V.

For instructions on selecting feedback resistors for other output voltages, see *Evaluating Other Output Voltages (Right Side)*.

Evaluating Other Output Voltages (Right Side)

The MAX1722 output is set to 3.6V by feedback resistors R1 and R2. To generate output voltages other than 3.6V (2.0V to 5.5V), select different external voltage-divider resistors (R1, R2). Refer to the Setting the Output Voltage section in the MAX1722/MAX1723/MAX1724 data sheet for instructions on selecting R1 and R2 for the MAX1722/MAX1723.

Evaluating the MAX1723

The MAX1723 can be evaluated using the MAX1722 circuit (right side). Replace the MAX1722 with a MAX1723EZK. Diode D1 (Motorola MBR0520L or equivalent) may be necessary for low-voltage startup. Refer to the Low-Voltage Startup Oscillator section in the MAX1722/MAX1723/MAX1724 data sheet for additional instructions on selecting D1.

MAX1724 Evaluation Kit

Evaluates: MAX1722/MAX1723/MAX1724

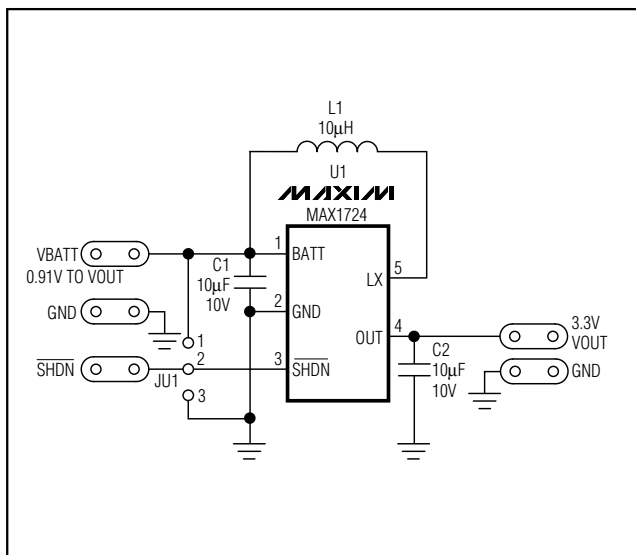

Figure 1. MAX1724 EV Kit Left-Side Circuit Schematic

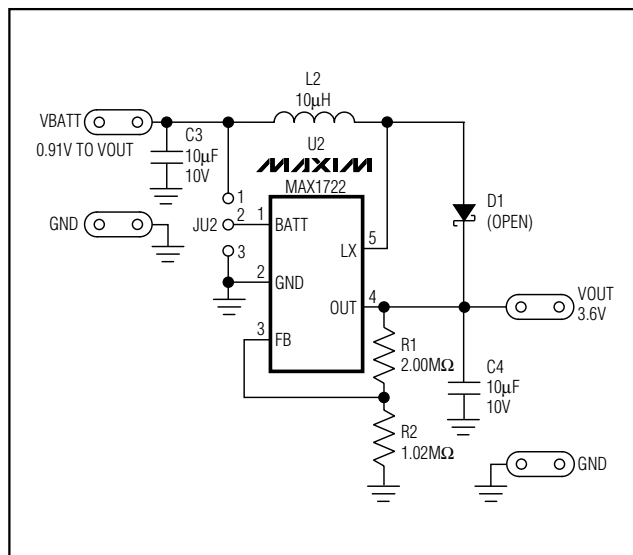

Figure 2. Right-Side Circuit Schematic for MAX1722 and MAX1723 Evaluation

The MAX1723 circuit features a shutdown mode that reduces current to 0.1µA (typ), preserving battery life. Jumper JU2 selects the MAX1723 shutdown mode. Table 3 lists the MAX1723 jumper options.

Table 3. MAX1723 Jumper JU2 Functions

SHUNT LOCATION	SHDN PIN	MAX1723 OUTPUT
1-2	Connected to VBATT	MAX1723 enabled, V _{OUT} = 3.6V
2-3	Connected to GND	Shutdown mode, V _{OUT} = V _{BATT} - V _{DIODE}

MAX1724 Evaluation Kit

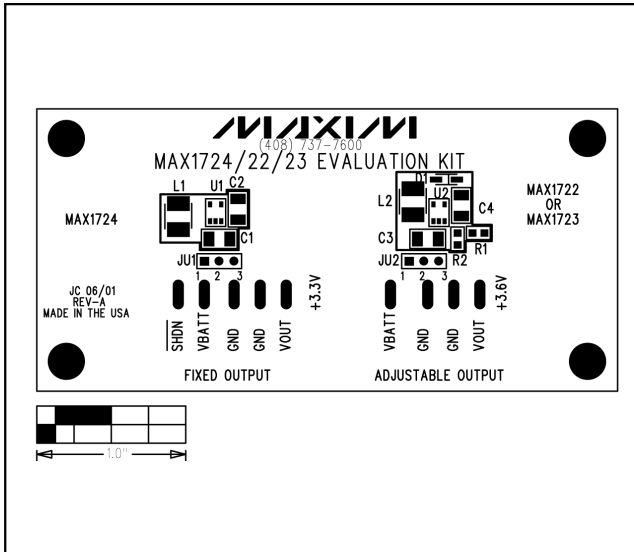

Figure 3. MAX1724 EV Kit Component Placement Guide—Component Side

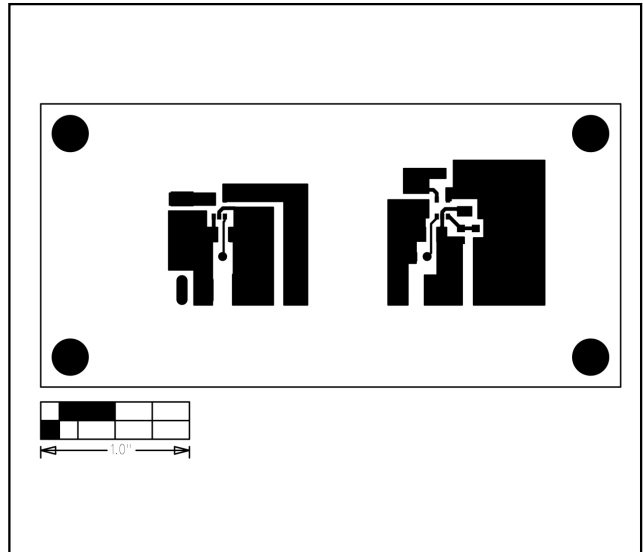

Figure 4. MAX1724 EV Kit PC Board Layout—Component Side

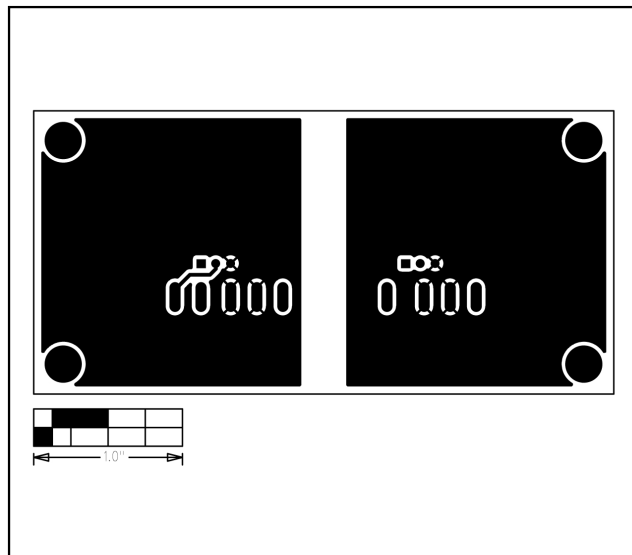

Figure 5. MAX1724 EV Kit PC Board Layout—Solder Side

Maxim cannot assume responsibility for use of any circuitry other than circuitry entirely embodied in a Maxim product. No circuit patent licenses are implied. Maxim reserves the right to change the circuitry and specifications without notice at any time.