

MAXIM

MAX1778 Evaluation Kit

General Description

The MAX1778 evaluation kit (EV kit) is a fully assembled and tested surface-mount circuit board that contains a step-up switching regulator, two charge-pump voltage-regulator circuits, a V_{COM} buffer, and a low-drop out linear regulator (LDO). The step-up switching circuit is configured for a +8V output that provides up to 250mA of current from a +3.0V supply. The EV kit can be powered from a +2.7V to +5.5V supply.

The positive charge-pump circuit is configured for a +20V output that provides more than 10mA of current. The negative charge-pump circuit is configured for a -5V output and provides more than 20mA of current. Power for both charge-pump inputs is provided from the step-up switching regulator output.

The EV kit also features an LDO linear regulator circuit, which is configured for a +2.5V output that provides more than 200mA of current. Power for the LDO regulator circuit is provided from the input supply. The V_{COM} buffer provides a +4V output and more than 150mA of peak current. The step-up switching regulator output provides power to the V_{COM} buffer.

The MAX1778 EV kit demonstrates low quiescent current and high efficiency (over 91%). High-frequency operation (500kHz/1MHz) allows the use of tiny surface-mount components and fast transient response. The MAX1778 TSSOP package (1.1mm max) with low-profile external components allows this circuit to be less than 1.2mm in height. A built-in transient load tester facilitates transient load tests. The MAX1778 EV kit can also be used to evaluate the MAX1880, MAX1881, and MAX1882 ICs.

Features

- ◆ +2.7V to +5.5V Input Range
- ◆ Output Voltages
 - +8V, >200mA (Step-Up Switching Regulator)
 - +20V, >10mA (Positive Charge-Pump Regulator)
 - 5V, >20mA (Negative Charge-Pump Regulator)
 - +2.5V, >200mA (LDO Linear Regulator)
 - +4V, >150mA Peak (V_{COM} Buffer)
- ◆ All Outputs Are Adjustable with Resistors
- ◆ >91% Efficiency
- ◆ Internal MOSFET Switches
- ◆ <1μA (typ) IC Shutdown Current
- ◆ 1MHz Step-Up Switching Regulator Frequency
- ◆ 500kHz Charge-Pump Regulator Switching Frequency
- ◆ Adjustable Fault-Trip Level
- ◆ Low-Profile External Components
- ◆ Built-In Transient Load Tester
- ◆ Surface-Mount Components
- ◆ Fully Assembled and Tested

Ordering Information

PART	TEMP. RANGE	IC PACKAGE
MAX1778EVKIT	0°C to +70°C	24 TSSOP

Component List

DESIGNATION	QTY	DESCRIPTION
C1, C16, C17, C18, C21	5	3.3μF ±10%, 10V X7R ceramic capacitors (1210) Taiyo Yuden LMK325BJ335KD
C2	1	0.47μF ±10%, 10V X7R ceramic capacitor (0603) Taiyo Yuden LMK107BJ474KA
C3, C14	2	0.01μF ±10%, 50V X7R ceramic capacitors (0603) Murata GRM39X7R103K050AD
C4, C6, C10, C22	4	0.1μF ±20%, 16V X7R ceramic capacitors (0603) Taiyo Yuden EMK107BJ104MA

DESIGNATION	QTY	DESCRIPTION
C5, C7, C11, C13, C25–C29	9	1μF ±10%, 16V X7R ceramic capacitors (1206) Murata GRM42-6X7R105K016
C8	1	1000pF ±10%, 50V X7R ceramic capacitor (0603) Murata GRM39X7R102K050AD
C9	1	0.22μF ±10%, 10V X7R ceramic capacitor (0603) Taiyo Yuden LMK107BJ224KA
C12, C20, C24	0	Not installed (0603)

Evaluates: MAX1778/MAX1880/MAX1881/MAX1882



MAX1778 Evaluation Kit

Component List (continued)

DESIGNATION	QTY	DESCRIPTION
C19	1	470pF $\pm 5\%$, 50V COH ceramic capacitor (0603) Taiyo Yuden UMK107CH4715Z
D1	1	3A, 30V Schottky diode (M-flat) Toshiba CMS02
D2, D3, D4	3	200mA, 25V Schottky diodes (SOT23) Fairchild BAT54S
D5	1	200mA, 75V ultra-fast diode (SOT23) Fairchild MMBD4148
L1	1	6.8 μ H inductor Coilcraft LPO25061B-682
N1	1	30V, 11.5A, N-channel MOSFET (SOT223) Fairchild Semiconductor NDT455N
Q1	1	40V, 600mA, NPN transistor (SOT23) Central Semiconductor CMPT2222A
R1	1	274k Ω $\pm 1\%$ resistor (0805)
R2, R4, R6	3	49.9k Ω $\pm 1\%$ resistors (0805)
R3	1	750k Ω $\pm 1\%$ resistor (0805)
R5	1	200k Ω $\pm 1\%$ resistor (0805)
R7	1	24k Ω $\pm 5\%$ resistor (0805)
R8, R10, R12	3	100k Ω $\pm 1\%$ resistors (0805)
R9	1	1M Ω $\pm 5\%$ resistor (0805)
R11, R13, R16	0	Not installed (0805)
R14, R15	2	10k Ω $\pm 1\%$ resistors (0805)
R17	1	51 Ω $\pm 5\%$ resistor (0805)
R18	1	1.0 Ω $\pm 1\%$, 1W resistor (2010) IRC LRC-LR 2010-01-1R00-F
R19	1	1.5k Ω $\pm 5\%$ resistor (0805)
R20	1	10 Ω $\pm 5\%$ resistor (0805)
R21	1	10k Ω $\pm 5\%$ resistor (0805)
U1	1	MAX1778EUG (24-pin TSSOP)
JU1	1	2-pin header
None	1	Shunt (JU1)
None	1	MAX1778 PC board
None	1	MAX1778 data sheet
None	1	MAX1778 EV kit data sheet

Component Suppliers

SUPPLIER	PHONE	FAX
Central Semiconductor	516-435-1110	516-435-1824
Coilcraft	847-639-6400	847-639-1469
Fairchild	408-822-2000	408-822-2102
IRC	512-992-7900	512-992-3377
Murata	814-237-1431	814-238-0490
Taiyo Yuden	408-573-4150	408-573-4159
Toshiba	949-455-2000	949-859-3963

Note: Please indicate that you are using the MAX1778, MAX1880, MAX1881, or MAX1882 when contacting these component suppliers.

Quick Start

The MAX1778 EV kit is fully assembled and tested. Follow these steps to verify board operation. **Do not turn on the power supply until all connections are completed.**

Output Verification

- 1) Verify that jumper JU1 (SHDN) does not have a shunt across its pins.
- 2) Connect a voltmeter to the V1 pad.
- 3) Connect a +2.7V to +5.5V DC power supply to the PIN pad. Connect the supply ground to the GND pad.
- 4) Turn on the power supply, and verify that the main output (V1) is +8V.
- 5) Verify that the negative charge-pump regulator output (VN) is -5V.
- 6) Verify that the positive charge-pump regulator output (VP) is +20V.
- 7) Verify that the LDO output (LDOOUT) is +2.5V.
- 8) Verify that the V_{COM} buffer output (BUFOUT) is +4V.

For instructions on selecting the feedback resistors for other output voltages, see *Evaluating Other Output Voltages*. The input voltage range is +2.7V to +5.5V when selecting the output voltage.

Detailed Description

The MAX1778 evaluation kit step-up switching regulator circuit can be configured for an output voltage up to +13V. A built-in transient load tester (TRANS_LOAD, CSEN) for the step-up switching regulator allows transient load tests up to 1A.

MAX1778 Evaluation Kit

Evaluates: MAX1778/MAX1880/MAX1881/MAX1882

The positive charge-pump circuit can be reconfigured to provide up to +35V by changing feedback resistors, provided that the step-up switching regulator (V1) has been changed to a higher voltage. The negative charge-pump circuit can also be reconfigured to provide up to -11V by changing feedback resistors, provided that the step-up switching regulator (V1) has been adjusted to a higher voltage.

The EV kit's LDO linear regulator circuit is configured for a +2.5V output (LDOOUT) at more than 200mA of current and can be reconfigured for other output voltages by replacing feedback resistors. When using an external transistor (Q1) for the LDO, regulator power for the LDO output is provided by PIN. When an external transistor (Q1) is not used, power is provided by the step-up switching regulator (V1). For even higher output current, the SOT23 NPN transistor (Q1) can be replaced with a larger D-PAK device.

The V_{COM} buffer output (BUFOUT) is a scaled down voltage of the step-up switching regulator (V1) and can be reconfigured for other voltages by replacing the voltage-divider resistors (R10, R11). The step-up switching regulator provides power to the V_{COM} buffer. A separate analog ground pad (GND) for the V_{COM} buffer output is provided to reduce noise coupling to the output.

The EV kit features an adjustable fault-trip level that can be reconfigured for different fault-trip levels. Unpopulated feedback-compensation PC board pads are provided for the step-up switching regulator. The linear regulator can be configured for different voltages and output currents.

The MAX1778 EV kit can also evaluate the MAX1880, MAX1881, and MAX1882. Order the IC from the phone number listed on page 1, and replace the MAX1778 with the appropriate IC.

Jumper Selection Shutdown Mode

The MAX1778 EV kit features a shutdown mode that reduces the MAX1778 quiescent current.

The 2-pin jumper (JU1) selects the MAX1778 shutdown mode. Table 1 lists the selectable jumper options.

Output Voltage Selection and Transient Load Test

Step-Up Switching-Regulator Output Voltages

The MAX1778 EV kit's step-up switching-regulator output is set to +8V by feedback resistors (R1, R2). To generate output voltages other than +8V (up to +13V), select different external voltage-divider resistors (R1, R2). The ceramic capacitors (C17, C18, C21) are rated

Table 1. Jumper JU1 Functions

SHUNT LOCATION	SHDN PIN	MAX1778 OUTPUT
None	Connected to PIN through R8	Enabled
Installed	Connected to GND	Shutdown

to +10V, so replace them with higher voltage-rated capacitors for output voltages over 10V. Refer to the *Output Voltage Selection* section in the MAX1778 data sheet for instructions on selecting the resistors.

Positive Charge-Pump Output Voltages

The MAX1778 EV kit's positive charge-pump regulator output is set to +20V by feedback resistors (R3, R4). To generate output voltages other than +20V (up to +35V), select different external voltage-divider resistors (R3, R4). Refer to the *Output Voltage Selection* section in the MAX1778/MAX1880–MAX1885 data sheet for instructions on selecting the resistors. **Check that the capacitor voltage rating is adequate for the configuration.**

Negative Charge-Pump Output Voltages

The MAX1778 EV kit's negative charge-pump regulator output is set to -5V by feedback resistors (R5, R6). To generate output voltages other than -5V (down to -11V), select different external voltage-divider resistors (R5, R6). Refer to the *Output Voltage Selection* section in the MAX1778/MAX1880–MAX1885 data sheet for instructions on selecting the resistors.

LDO Regulator Output Voltages

The MAX1778 EV kit's LDO linear regulator output is set to +2.5V by feedback resistors (R14, R15). To generate output voltages other than +2.5V (+1.25V to V_{PIN} -300mV), select different external voltage-divider resistors (R14, R15). Refer to the *Output Voltage Selection* section in the MAX1778 data sheet for instructions on selecting the resistors. The power dissipation of the NPN transistor (Q1, 350mW) must not be exceeded. If a larger transistor is required, a "DPAK" surface-mount case may be used to replace Q1 (MJD31, On Semiconductor, or similar recommended). Refer to the *External Pass Transistor* section in the MAX1778/MAX1880–MAX1885 data sheet for instructions on selecting a transistor.

V_{COM} Buffer Output Voltages

The MAX1778 EV kit's V_{COM} buffer output (BUFOUT) is configured to one half of V1's output voltage (i.e., 0.5 × 8V = +4V) by using the MAX1778 IC's internal 0.5 volt-

MAX1778 Evaluation Kit

age divider. Select different external voltage-divider resistors (R10, R11) to generate output voltages other than +4V (+1.2V to $+(V_{SUPB} - 1.2V)$). Refer to the *Output Voltage Selection* section in the MAX1778/MAX1880–MAX1885 data sheet for instructions on selecting the resistors. The VCOM buffer has a separate analog ground pad (GND) next to the VCOM buffer output (BUFOUT) to reduce any noise coupling.

Transient Load Tester

The MAX1778 EV kit features a built-in transient load tester for the step-up switching regulator. Connect a square-wave function generator (50Ω output) to the TRANS_LOAD and GND pads. Set the frequency and duty cycle as required. Note that varying the function generator output voltage (2.0V typ to 10V max) will vary the gate drive and thus will vary the amount of load connected to V1. Set the low and high voltage of the square-wave output according to the desired low- and high-load currents. Load currents can be calculated by measuring the voltage at the CSEN pad (across R18, 1Ω) and GND. Divide the measured voltage by 1Ω to obtain the actual load current.

Faults and Maximizing Transient Performance

Fault-Trip Level

The MAX1778 EV kit's fault-trip level for the step-up switching regulator and the positive charge pump is configured for a +1.1V ($0.67 \times V_{REF}$ to $0.87 \times V_{REF}$) fault-trip level. To reconfigure the EV kit for other fault-trip levels (+0.84V to +1.09V), select different external voltage-divider resistors (R12, R13). Refer to the *Fault-Trip Level* (FLTSET) section in the MAX1778/MAX1880–MAX1885 data sheet for instructions on selecting the resistors.

Table 2. Component List for Evaluating Other Linear Regulators

DESIGNATOR	CASE 1	CASE 2	CASE 3	CASE 4
LDO Output Voltage (LDOOUT)	+7.6V (V1 set to 8V)	+9V to +12.4V (V1 set to 13V)	+3.3V	+2.5V
LDO Output Current (LDOOUT)	40mA	40mA	300mA to 500mA	200mA
Q1 (external NPN)	Not installed	Not installed	D-PAK (MJD31)	SOT23 (2N2222A)
C3	Not installed	Not installed	0.01μF	0.01μF
C14	Not installed	Not installed	0.01μF	0.01μF
C27	3.3μF	2.2μF	1.0μF	1.0μF
C29	Not installed	Not installed	1.0μF	1.0μF
R14	10kΩ	10kΩ	10kΩ	10kΩ
R15	51.1kΩ	60kΩ to 89kΩ	16.5kΩ	10kΩ
R16	0Ω	0Ω	Not installed	Not installed
R19	13kΩ	13kΩ	4.02kΩ	3.01kΩ

Maximizing Transient Performance

The MAX1778 EV kit features several surface-mount, unpopulated PC board pads for installing feedback compensation components (R7, C19, C20). To maximize the transient load performance, remove capacitor C8, connect the INTG pin (pin 2) to the REF pin (pin 9) of IC U1, and remove resistor R7 and capacitor C19. Refer to the *Feedback Compensation* section in the MAX1778/MAX1880–MAX1885 data sheet for instructions on selecting other resistors and capacitors.

Evaluating Other ICs and Different Linear Regulator Configurations

Evaluating a MAX1880, MAX1881, or MAX1882

The MAX1778 EV kit can be reconfigured for evaluating the MAX1880, MAX1881, and MAX1882 ICs. U1 (MAX1778) must be removed and replaced with the new IC (24-pin TSSOP package). The linear regulator will not function when evaluating a MAX1880 or MAX1882. Refer to the MAX1778/MAX1880–MAX1885 IC data sheet for information on the various step-up switching frequency and LDO features.

Linear Regulator Voltages

The MAX1778 EV kit can be reconfigured for evaluating other linear regulator voltages and currents. Several components must be replaced to obtain higher voltages or currents. Table 2 lists the components to replace.

MAX1778 Evaluation Kit

Evaluates: MAX1778/MAX1880/MAX1881/MAX1882

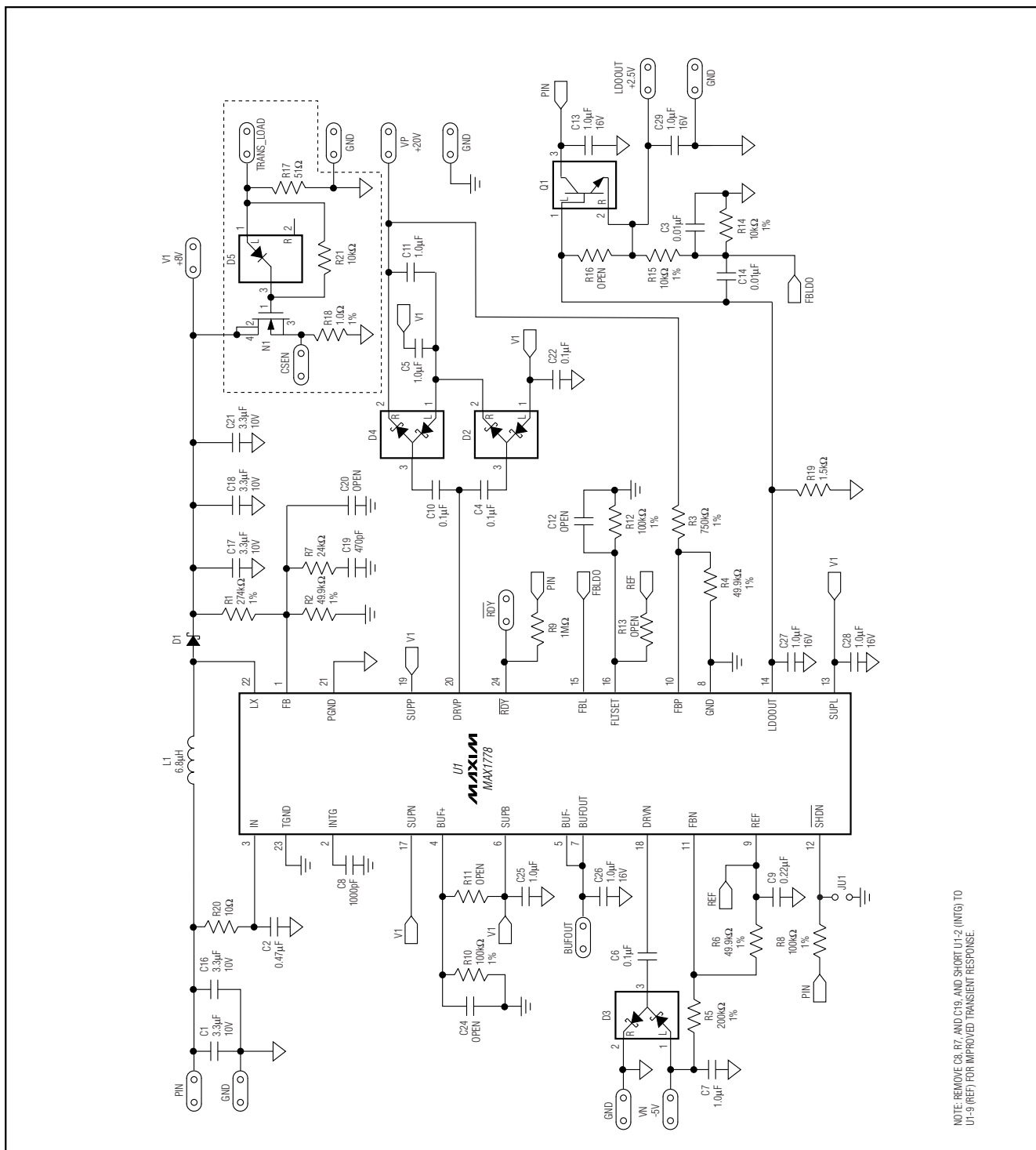

NOTE: REMOVE C8, R7, AND SHORT U1-2 (INTG) TO U1-9 (REF) FOR IMPROVED TRANSIENT RESPONSE.

Figure 1. MAX1778 EV Kit Schematic

MAX1778 Evaluation Kit

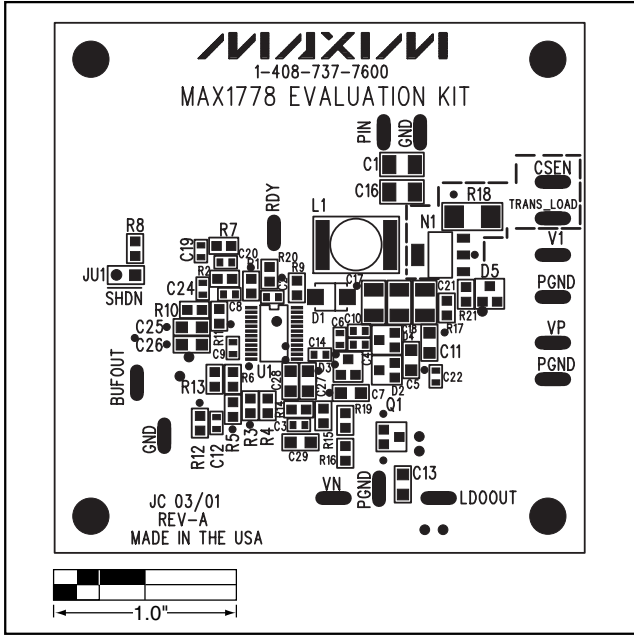

Figure 2. MAX1778 EV Kit Component Placement Guide—Component Side

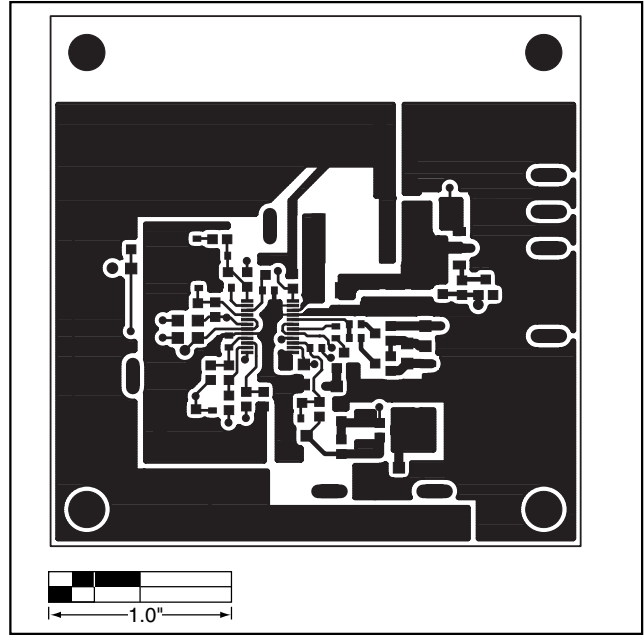

Figure 3. MAX1778 EV Kit PC Board Layout—Component Side

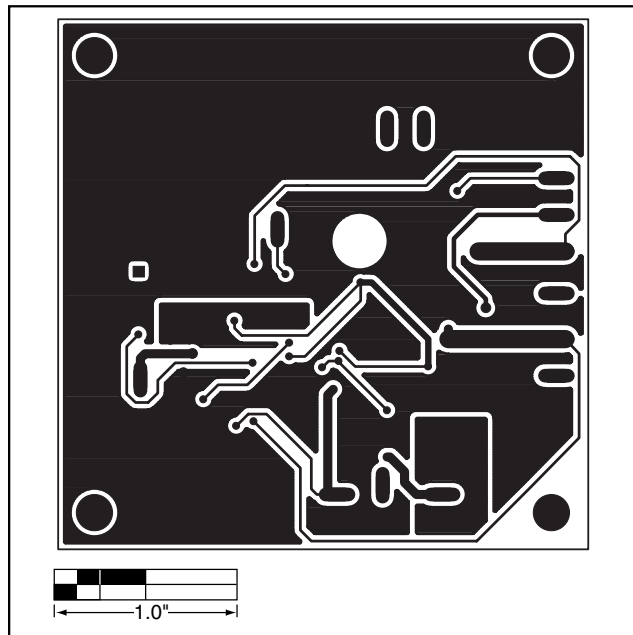

Figure 4. MAX1778 EV Kit PC Board Layout—Solder Side

Maxim cannot assume responsibility for use of any circuitry other than circuitry entirely embodied in a Maxim product. No circuit patent licenses are implied. Maxim reserves the right to change the circuitry and specifications without notice at any time.