



MAX038 Evaluation Kit

General Description

The MAX038 evaluation kit (EV kit) is a high-frequency function generator capable of producing accurate triangle/sawtooth, sine, and square/pulse waveforms up to 10MHz, using the supplied components. Output frequency and duty cycle are easily adjusted with on-board potentiometers. Removable jumpers select sine, square, or triangle waveforms, or fix the duty cycle at 50%. The output is buffered with a MAX442 amplifier capable of driving a 50Ω coaxial cable. The MAX038 EV kit is fully assembled and tested.

Ordering Information

PART	TEMP. RANGE	BOARD TYPE
MAX038EVKIT-DIP	0°C to +70°C	Through-Hole

EV Kit

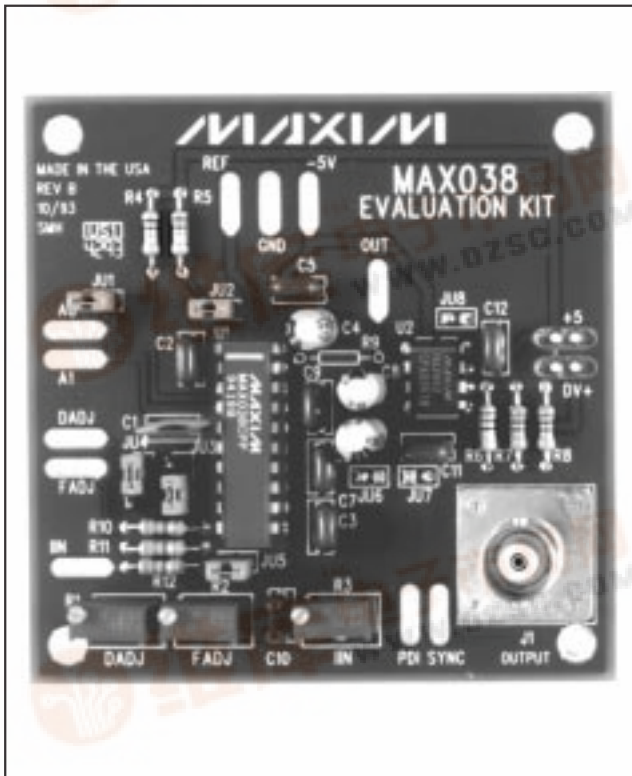

Features

- ◆ 325kHz to 10MHz Operation
- ◆ Adjustable Duty Cycle
- ◆ 2.5V Reference Output
- ◆ TTL-Compatible SYNC Output
- ◆ Fully Assembled and Tested

Component List

DESIGNATION	QTY	DESCRIPTION
U1	1	MAX038CPP
U2	1	MAX442CPA
C1	1	82pF capacitor
C2, C3, C5, C7, C9, C10, C11, C12	8	0.1μF capacitors
C4, C6, C8	3	4.7μF capacitors
R1, R2	2	20kΩ potentiometers
R3	1	50kΩ potentiometer
R4, R5	2	10kΩ, 5% resistors
R6	1	51Ω, 5% resistor
R7, R8	2	270Ω, 5% resistors
R9, R10, R11	3	0Ω resistors
R12	1	3.3kΩ, 5% resistor
JU1, JU2, JU5	3	2-pin headers
JU3, JU4	2	3-pin headers
None	5	Shunts
J1	1	BNC jack

Quick Start

The MAX038 EV kit is a fully assembled and tested board. Follow these steps to verify board operation. **Do not turn on the power supply until all connections are completed.**

- 1) Connect a +5V supply to the pad marked +5V. Connect a -5V supply to the pad marked -5V. Connect ground(s) to the GND pad.
- 2) Connect an oscilloscope to the BNC jack marked OUTPUT through a terminated 50Ω cable. The MAX038 output prior to the amplifier stage may also be monitored using an oscilloscope probe at the OUT pad.
- 3) Place the shunt across pins 2 and 3 of JU4 for 50% duty cycle. Place the shunt across pins 1 and 2 of

Evaluates: MAX038



MAX038 Evaluation Kit

JU3 to allow the frequency to be adjusted. Verify that there is a shunt on JU5.

- 4) Verify the shunts on JU1 and JU2 for a square-wave output. Refer to Table 1 for alternate waveform selections.
- 5) Apply power and verify the output waveform.

Detailed Description

Waveform Selection

To select the desired output waveform, place shunts across JU1 and JU2 in the combinations shown in Table 1. These jumpers set address pins A0 and A1 to TTL/CMOS-logic levels. External control may be initiated by connecting an external source to the A0 and A1 pads and removing the shunts on JU1 and JU2. Note that there are 10k Ω pull-up resistors to +5V on the A0 and A1 address lines.

Table 1. Waveform Jumper Select

JU1	JU2	OUTPUT WAVEFORM
Don't Care	Open	Sine Wave
Open	Short	Triangle Wave
Short	Short	Square Wave

Table 2. Frequency and Duty-Cycle Jumper Select

JUMPER	SHUNT LOCATION	MAX038 OUTPUT
JU3	1 & 2	Adjustable Frequency
	2 & 3	Pre-Set Frequency*
JU4	1 & 2	Adjustable Duty Cycle
	2 & 3	Fixed 50% Duty Cycle

* Note: Frequency pre-set by oscillator capacitor (C1) and input current (position of R3) as specified by formula [1].

Output Frequency

The output frequency is controlled by the oscillator capacitor (C1), the current injected into the IIN pin, and the voltage on the FADJ pin. The EV kit allows independent adjustment of both input current (R3) and FADJ voltage (R2). Refer to the *Detailed Description* section of the MAX038 data sheet for additional theory of operation.

Input Current Control

The current injected into the IIN pin acts as the primary frequency-adjustment control. The R3 potentiometer varies the current to the MAX038's IIN pin. The input current can be easily monitored by removing the JU5 shunt and placing a current meter across the JU5 pins. The components supplied on the EV kit will allow an input current range of 50 μ A to 725 μ A. With the VADJ pin grounded, the fundamental output frequency (F_o) is as follows:

$$F_o \text{ (MHz)} = I_{IN}(\mu\text{A}) \div C_{OSC} \text{ (pF)} \quad [1]$$

where: I_{IN} = current injected into IIN

$$= V_{REF} \div (R3 + R12)$$

$$= 2.5\text{V} \div (0\text{k}\Omega \text{ to } 50\text{k}\Omega + 3.3\text{k}\Omega)$$

C_{OSC} = external oscillator capacitor (C1)

To use an external input current, connect the external current source to the IIN pad and remove the JU5 shunt completely. Note that there is a 3.3k Ω resistor in series with the device IIN pin.

FADJ Control

Varying the FADJ voltage will also vary the output frequency. With a shunt across pins 1 and 2 of JU3, the R2 potentiometer will vary the voltage applied to the FADJ pin. With the JU3 shunt on pins 2 and 3, the FADJ pin is grounded. Grounding the FADJ pin sets the output to the fundamental output frequency (F_o), as given by equation [1].

To use an external FADJ voltage, connect the external source to the FADJ pad and remove the JU3 shunt completely. Limit the external FADJ voltage to $\pm 2.4\text{V}$.

Duty-Cycle Control

The voltage on the DADJ pin controls the duty cycle of the output waveform. With the JU4 shunt on pins 1 and 2, the R1 potentiometer will vary the voltage applied to the DADJ pin, thus varying the duty cycle 15% to 85%. With the JU4 shunt on pins 2 and 3, the DADJ pin is grounded. Grounding the DADJ pin fixes the duty cycle at 50%.

To use an external DADJ voltage, connect the external voltage source to the DADJ pad and remove the JU4 shunt completely. Limit the external DADJ voltage to $\pm 2.3\text{V}$.

MAX038 Evaluation Kit

Evaluates: MAX038

Output Buffer

The MAX038 output amplitude is fixed at $2V_{p-p}$. The MAX038 output is capable of driving a capacitive load up to $90pF$. The MAX442 amplifier buffers the MAX038 output to a 50Ω coaxial cable. The MAX442 is set at a gain of $2V/V$, so that the output amplitude remains $1V/V$ after the 50Ω back termination. The EV kit's OUT pad provides access to the output of the MAX038 prior to the MAX442 buffer stage. The MAX442 output connects to the BNC connector through a 50Ω resistor to back terminate a 50Ω coaxial cable. When a terminated 50Ω cable is connected, this resistor forms a voltage divider with the load impedance, which attenuates the signal by one-half. The MAX442 is operated with a $2V/V$ closed-loop gain to provide unity gain at the 50Ω cable's output.

The MAX442 is actually a 2-channel amplifier. A built-in multiplexer allows either of two input signals to be selected. TTL-level address pin A0 selects either IN0 or IN1. The MAX038 output is connected to MAX442 input IN0. IN1 is unused and connected to ground; it may be used by cutting the JU7 trace, thus disconnecting IN1 from ground. Likewise, the MAX442 address pin A0 can be disconnected from ground by cutting the JU8 trace. Pull up A0 to +5V to select IN1. See the MAX442 data sheet for additional operation details.

Reference Voltage

The MAX038 includes a $2.5V$ bandgap reference capable of sourcing $4mA$ and sinking $100\mu A$. Access to the reference voltage is provided at the REF pad. The reference voltage is primarily used to provide stable current to IIN and to bias DADJ and FADJ.

Extending the Output Frequency Range

The components supplied with the EV kit allow an output frequency range of $325kHz$ to $10MHz$. The frequency range is controlled primarily by the oscillator capacitor (C1) and the input current, which is a function of the reference voltage and potentiometer R3. The resulting frequency range can be shifted up or down depending on the value of C1. Refer to the Output Frequency vs. Input Current graph which appears in the *Typical Operating Characteristics* of the MAX038 data sheet.

The upper end of the range can be extended by reducing C1. The lower end of the range can be reduced by increasing the value of C1. Take care when selecting alternate capacitors if stable operation over temperature is desired. Ceramic capacitors with low temperature coefficients give the best results. Refer to the *Selecting Resistors and Capacitors* section of the MAX038 data sheet for further details.

Sync Output and Phase-Detector Input

Refer to the *SYNC Output* and *Phase Detector* sections of the MAX038 data sheet for details of circuit synchronization. Access to the Phase Detector Input (PDI) and SYNC is provided at pads PDI and SYNC.

High-speed transient currents in DGND and DV+ can cause a switching spike in the output waveform at the zero-crossing point. A lowpass output filter, as shown in Figure 3 of the MAX038 data sheet, may be used to greatly reduce the spike. Complete LC filter assemblies (S3LP series) are available from Coilcraft (phone: 708-639-6400). If the SYNC output is not required, disabling the SYNC circuit will eliminate the switching spike. Cut the trace between the DV+ and +5V pads to disable the SYNC output.

MAX038 Evaluation Kit

Evaluates: MAX038

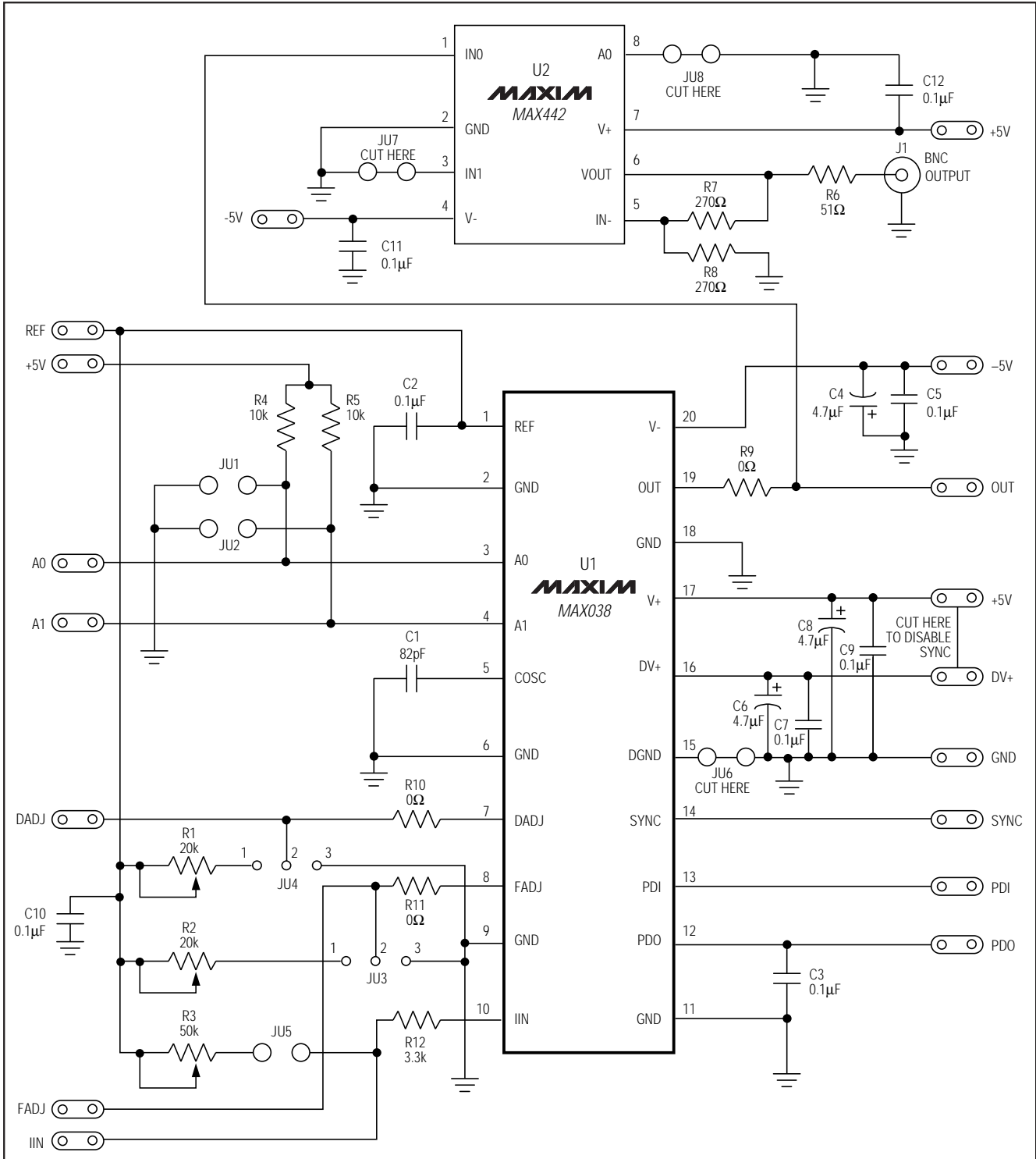

Figure 1. MAX038 EV Kit Schematic

MAX038 Evaluation Kit

Evaluates: MAX038

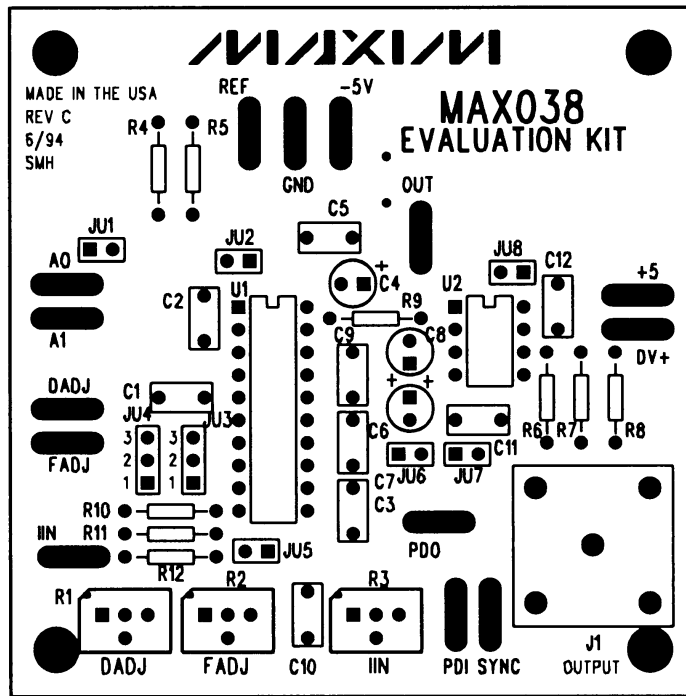

Figure 2. MAX038 EV Kit Component Placement Guide—Component Side

MAX038 Evaluation Kit

Evaluates: MAX038

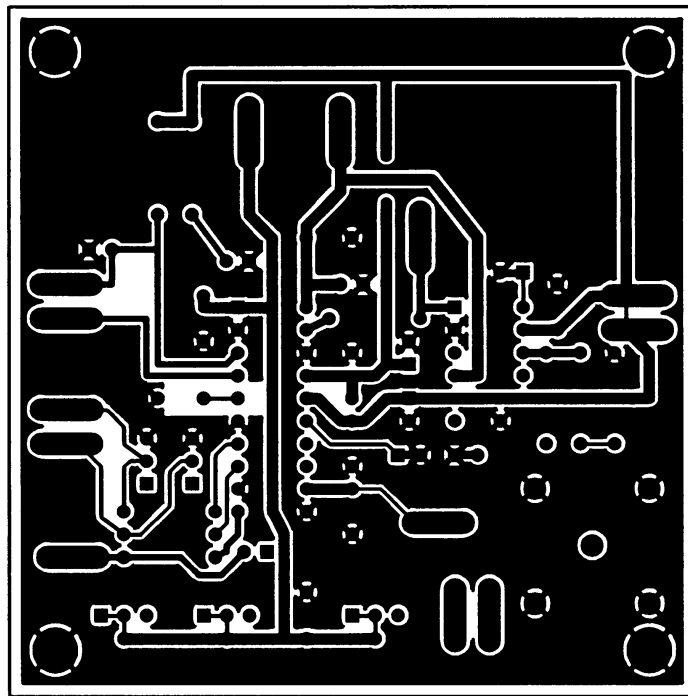

Figure 3. MAX038 EV Kit PC Board Layout—Component Side

MAX038 Evaluation Kit

Evaluates: MAX038

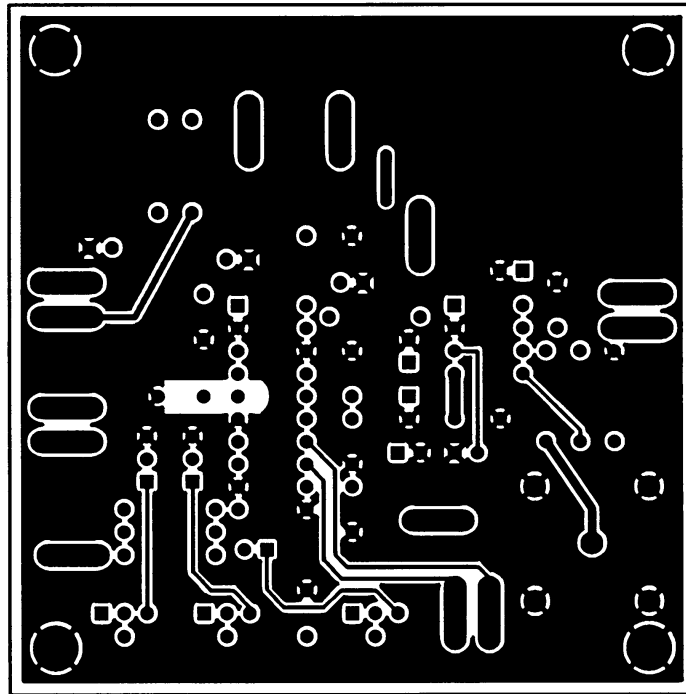

Figure 4. MAX038 EV Kit PC Board Layout—Solder Side

Evaluates: MAX038

MAX038 Evaluation Kit

NOTES

Maxim cannot assume responsibility for use of any circuitry other than circuitry entirely embodied in a Maxim product. No circuit patent licenses are implied. Maxim reserves the right to change the circuitry and specifications without notice at any time.

8 _____ Maxim Integrated Products, 120 San Gabriel Drive, Sunnyvale, CA 94086 408-737-7600