



MAX2640/MAX2641 Evaluation Kits

General Description

The MAX2640/MAX2641 evaluation kits (EV kits) simplify the evaluation of the MAX2640/MAX2641 low-noise amplifiers (LNAs). They enable testing of the device's RF performance and require no additional support circuitry. The signal inputs and outputs use SMA connectors to facilitate the connection of RF test equipment.

The MAX2640 EV kits are assembled with the MAX2640 and incorporate input and output matching components optimized for an RF frequency of 900MHz. The MAX2641 EV kits are assembled with the MAX2641 and incorporate input and output matching components optimized for an RF frequency of 1900MHz. All matching components may be changed to match RF frequencies from 400MHz to 1500MHz for the MAX2640 and from 1400MHz to 2500MHz for the MAX2641. Consult Tables 1 through 4 in the MAX2640/MAX2641 data sheet for device S-parameters and noise parameters for the design of matching networks at other frequencies.

Component Suppliers

SUPPLIER	PHONE	FAX
Coilcraft	847-639-6400	847-639-1469
Murata Electronics	800-831-9172	814-238-0490

Features

- ◆ Easy Evaluation of MAX2640/MAX2641
- ◆ +2.7V to +5.5V Single-Supply Operation
- ◆ RF Input and Output Matched to 50Ω at 900MHz (MAX2640)
- ◆ RF Input and Output Matched to 50Ω at 1900MHz (MAX2641)
- ◆ All Critical Peripheral Components Included

Ordering Information

PART	TEMP. RANGE	IC PACKAGE	SOT TOP MARK
MAX2640EVKIT	-40°C to +85°C	SOT23-6	AAAV
MAX2641EVKIT	-40°C to +85°C	SOT23-6	AAAW

Component List

DESIGNATION		QTY	DESCRIPTION
MAX2640 EV Kit	MAX2641 EV Kit		
C1, C4	C1, C4	2	470pF 5% ceramic caps (0805) Murata GRM40COG471J50V
C2	—	1	3pF ±0.1pF ceramic cap (0805) Murata GRM40COG3R0B50V
—	C2	1	100pF 5% ceramic cap (0805) Murata GRM40COG101J50V
C3	C3	1	10µF ceramic cap (1206) AVX TAJA106K010R
ZM1	—	1	2pF ±0.1pF ceramic cap (0805) Murata GRM40COG2R0B50V
—	ZM1, ZM2	2	1pF ±0.1pF ceramic caps (0603) Murata GRM39COG1R0B50V
ZM2	—		Not installed

DESIGNATION		QTY	DESCRIPTION
MAX2640 EV Kit	MAX2641 EV Kit		
Z1	—	1	9.85nH 5% air-core inductor Coilcraft 1606-9-5
—	Z1	1	2.55nH 5% air-core inductor Coilcraft 0906-3-5
RFIN, RFOUT	RFIN, RFOUT	2	SMA connectors (PC edge mount) EF Johnson 142-0701-801
U1	—	1	MAX2640EUT-T (topmark: AAAV), 6-pin SOT23-6
—	U1	1	MAX2641EUT-T (topmark: AAAW), 6-pin SOT23-6
None	—	1	MAX2640 EV kit PC board
—	None	1	MAX2641 EV kit PC board

Evaluate: MAX2640/MAX2641



MAX2640/MAX2641 Evaluation Kits

Quick Start

The MAX2640/MAX2641 EV kits are fully assembled and factory tested. Follow the instructions in the *Connections and Setup* section for proper device evaluation.

Test Equipment Required

This section lists the recommended test equipment to verify operation of the MAX2640/MAX2641. It is intended as a guide only, and some substitutions are possible.

- One RF signal generator capable of delivering at least 0dBm of output power up to 2.5GHz (HP8648C, or equivalent)
- An RF spectrum analyzer that covers the operating frequency range of the MAX2640/MAX2641 as well as a few harmonics (HP8561E, for example)
- A power supply capable of up to 100mA at +2.7V to +5.5V
- An optional ammeter for measuring the supply current
- Two 50Ω SMA cables
- (Optional) A noise figure meter (HP8970B, for example)
- (Optional) Network analyzer (HP8753D, for example) to measure return loss and gain

Connections and Setup

Checking Power Gain

This section provides a step-by-step guide to operating the EV kits and their function.

- 1) Connect a DC supply set to +3V (through an ammeter, if desired) to the V_{CC} and GND terminals on the EV kit.
- 2) Set the generator for an output frequency of 900MHz for the MAX2640 and 1900MHz for the MAX2641 at a power level of -34dBm. Connect one RF signal generator to the RFIN SMA connector.
- 3) Connect a spectrum analyzer to the RFOUT SMA connector on the EV kit. Set it to a center frequency of 900MHz for the MAX2640 and 1900MHz for the MAX2641, a total span of 200MHz, and a reference level of -10dBm.
- 4) Turn on the DC supply. The supply current should read approximately 3.5mA for either the MAX2640 or MAX2641 (if using an ammeter).
- 5) Activate the RF generator's output. A signal on the spectrum analyzer's display should indicate a typi-

cal gain of 15.1dB for the MAX2640 and 14.4dB for the MAX2641 after accounting for cable and board losses. Table EV1 lists board losses at specific frequencies.

- 6) (Optional) Another method for determining gain is using a network analyzer. This has the advantage of displaying gain versus a swept frequency band, in addition to displaying input and output return loss. Refer to the network analyzer manufacturer's user manual for setup details.

Checking Noise Figure

Noise figure measurements on low-noise devices such as the MAX2640/MAX2641 are extremely sensitive to board and lab setup losses and parasitics. There are many techniques and precautions for measuring a noise figure below 1dB. Detailed explanation of these items goes beyond the scope of this document. For more information on how to perform this level of noise figure measurement, refer to the noise figure meter operating manual as well as the Hewlett Packard application note # 57-2 "Noise Figure Measurement Accuracy."

Layout Considerations

A good PC board layout is an essential part of an RF circuit design. The EV kit PC board can serve as a guide for laying out a board using the MAX2640/MAX2641. Generally, each V_{CC} node on the PC board should have its own decoupling capacitor. This minimizes supply coupling from one section of the IC to another. A star topology for the supply layout, in which each V_{CC} node on the circuit has a separate connection to a central V_{CC} node, can further minimize coupling between sections of the circuit board.

Modifying the EV kit

The MAX2640 EV kit is factory-configured for operation at 900MHz and is easily configured to operate from 400MHz to 1500MHz. Use device parameters listed in Tables 1 and 3 of the MAX2640/MAX2641 data sheet to determine the proper input and output matching components at other frequencies. To evaluate the MAX2641 at frequencies other than the factory configured 1900MHz, use device parameters listed in Tables 2 and 4 of the MAX2640/MAX2641 data sheet to determine the proper input and output matching components. Table 1 lists recommended matching component values for the MAX2641 at 1575MHz and 2450MHz.

The MAX2640/MAX2641 are designed for AC-coupled operation. When determining matching components for other frequencies, ensure that a DC-blocking capacitor is part of the matching network.

MAX2640/MAX2641 Evaluation Kits

Evaluate: MAX2640/MAX2641

Table 1. MAX2640/MAX2641 EV Kit Board and Component Losses and Matching Component Values

FREQUENCY (MHz)		C1 VALUE (pF)	C2 VALUE (pF)	C5	Z1* VALUE (nH)	ZM1 VALUE (pF)	ZM1 POSITION	ZM2 VALUE	ZM2 POSITION	INPUT LOSS (dB)	OUTPUT LOSS (dB)
MAX2640	MAX2641										
900	—	470	3	Open	9.85	2	22	—	—	0.25	0.15
—	1575	100	100	Open	5.6	1	9.5	6.8nH†	11.5	0.37	0.30
—	1900	470	100	Open	2.55	1	9.5	1pF	25.5	0.41	0.30
—	2450	470	100	100pF	1.65	1	4	1pF	12	0.56	0.50

*The series inductor can be replaced by a transmission line of appropriate impedance and electrical length.
 †6.8nH Murata LQP11A6N8C00 (0603)

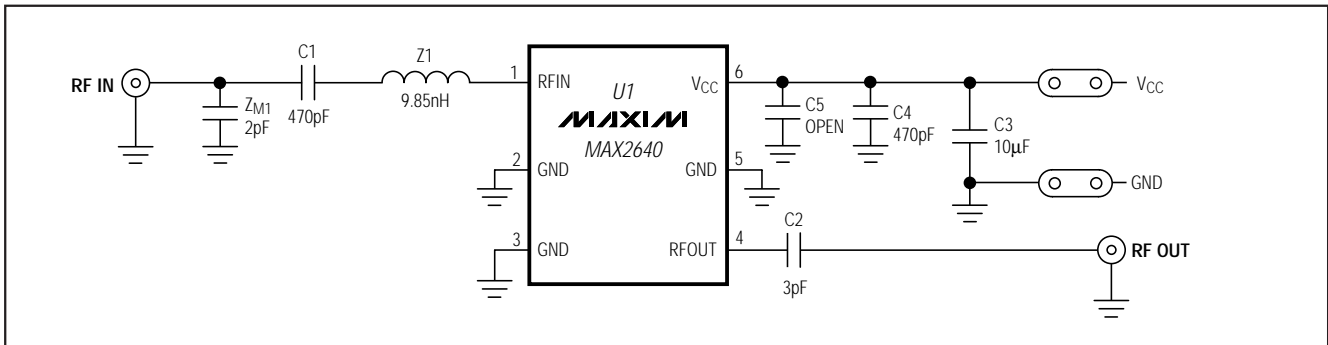

Figure 1. MAX2640 EV Kit Schematic

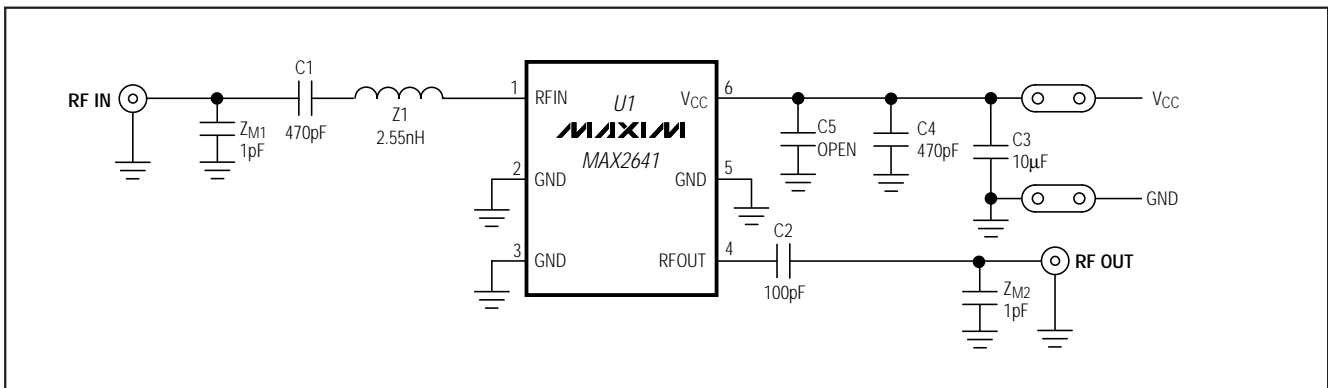

Figure 2. MAX2641 EV Kit Schematic

MAX2640/MAX2641 Evaluation Kits

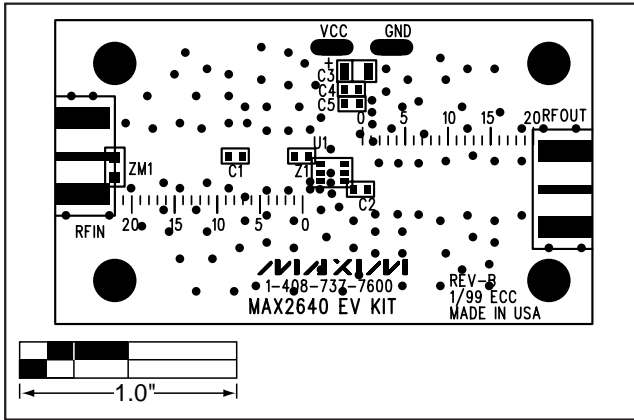

Figure 3. MAX2640 EV Kit Component Placement Guide—Component Side

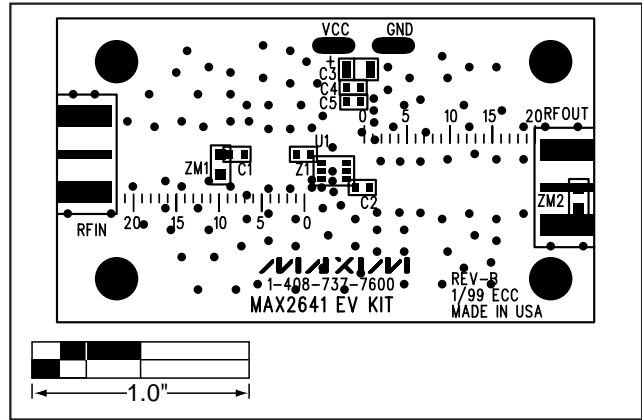

Figure 4. MAX2641 EV Kit Component Placement Guide—Component Side

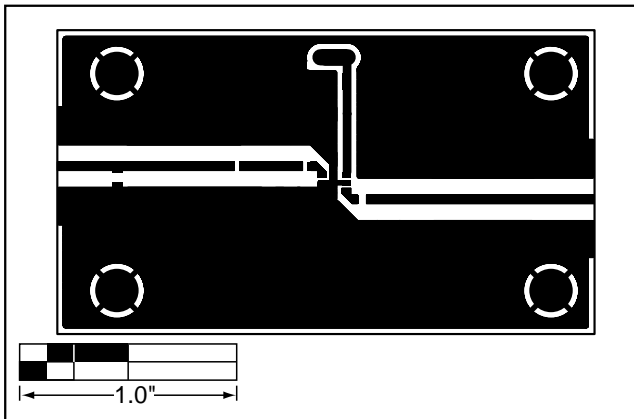

Figure 5. MAX2640 EV Kit PC Board Layout—Component Side

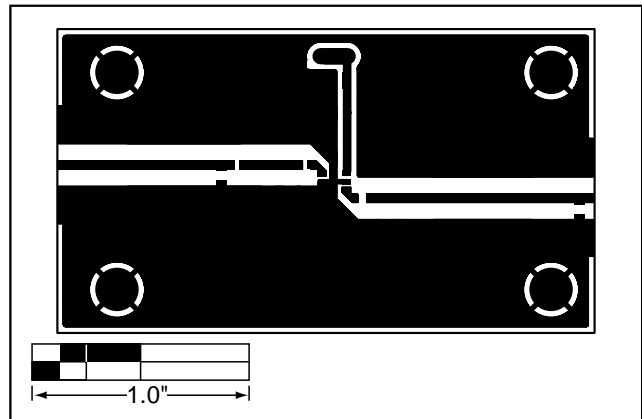

Figure 6. MAX2641 EV Kit PC Board Layout—Component Side

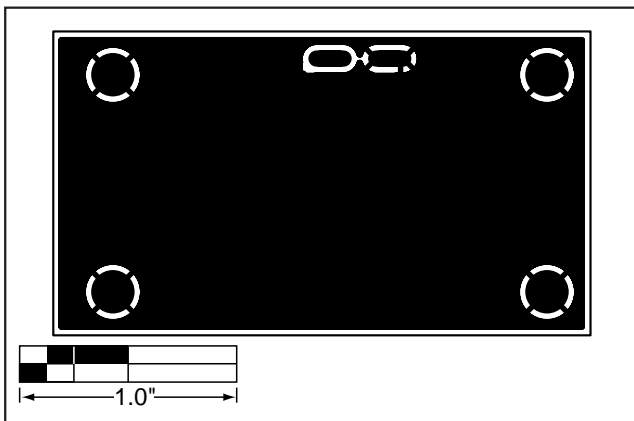

Figure 7. MAX2640/MAX2641 EV Kit PC Board Layout—Ground Plane

Maxim cannot assume responsibility for use of any circuitry other than circuitry entirely embodied in a Maxim product. No circuit patent licenses are implied. Maxim reserves the right to change the circuitry and specifications without notice at any time.

4 _____ Maxim Integrated Products, 120 San Gabriel Drive, Sunnyvale, CA 94086 408-737-7600