



FEATURES

- **UL Rated Isolated RS485: 2500V_{RMS}**
UL Recognized File #E151738
- Half- or Full-Duplex
- **Eliminates Ground Loops**
- **250kBd Maximum Data Rate**
- **Self-Powered with 420kHz Converter**
- Fail-Safe Output High for Open or Shorted Receiver Inputs
- Short-Circuit Current Limit
- Slow Slew Rate Control
- 68kΩ Input Impedance Allows Up to 128 Nodes
- Thermal Shutdown
- 8kV ESD Protection On Driver Outputs and Receiver Inputs

APPLICATIONS

- Isolated RS485 Receiver/Driver
- RS485 with Large Common Mode Voltage
- Breaking RS485 Ground Loops
- Multiple Unterminated Line Taps

DESCRIPTION

The LTC[®]1535 is an isolated RS485 full-duplex differential line transceiver. Isolated RS485 is ideal for systems where the ground loop is broken to allow for much larger common mode voltage ranges. An internal capacitive isolation barrier provides 2500V_{RMS} of isolation between the line transceiver and the logic level interface. The powered side contains a 420kHz push-pull converter to power the isolated RS485 transceiver. Internal full-duplex communication occurs through the capacitive isolation barrier. The transceiver meets RS485 and RS422 requirements.

The driver and receiver feature three-state outputs, with the driver maintaining high impedance over the entire common mode range. The drivers have short-circuit current limits in both directions and a slow slew rate select to minimize EMI or reflections. The 68kΩ receiver input allows up to 128 node connections. A fail-safe feature defaults to a high output state when the receiver inputs are open or shorted.

LTC, LTC and LT are registered trademarks of Linear Technology Corporation.

TYPICAL APPLICATION

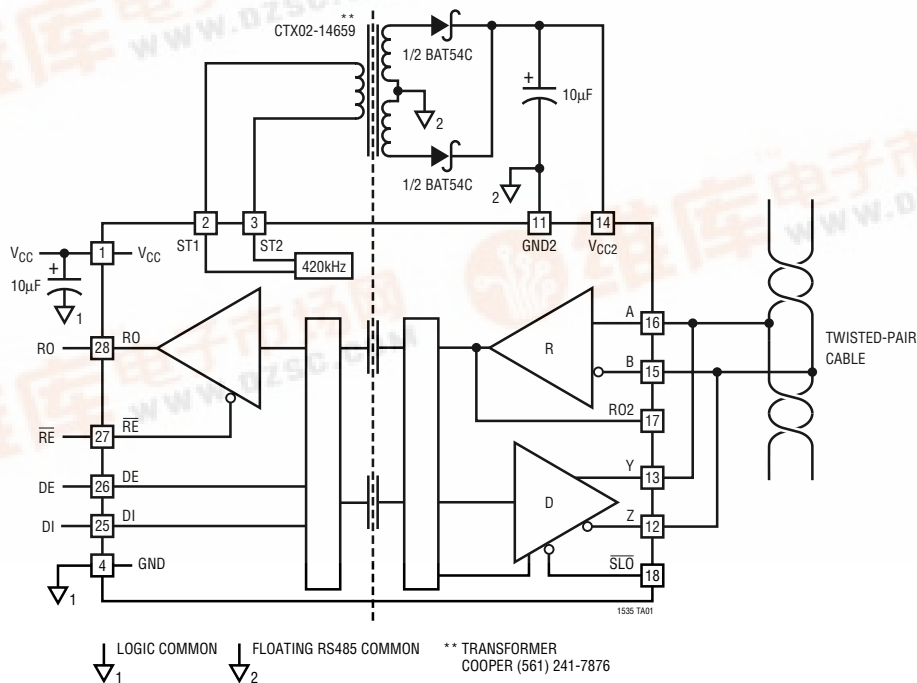

LTC1535

ABSOLUTE MAXIMUM RATINGS

(Note 1)

V_{CC} to GND	6V
V_{CC2} to GND2	8V
Control Input Voltage to GND	-0.3V to ($V_{CC} + 0.3V$)
Driver Input Voltage to GND	-0.3V to ($V_{CC} + 0.3V$)
Driver Output Voltage (Driver Disabled) to GND2	($V_{CC2} - 13V$) to 13V
Driver Output Voltage (Driver Enabled) to GND2	($V_{CC2} - 13V$) to 10V
Receiver Input Voltage to GND2	$\pm 14V$
Receiver Output Voltage	-0.3V to ($V_{CC} + 0.3V$)
Operating Temperature Range	
LTC1535C	$0^{\circ}C \leq T_A \leq 70^{\circ}C$
LTC1535I	$-40^{\circ}C \leq T_A \leq 85^{\circ}C$
Storage Temperature Range	$-65^{\circ}C$ to $150^{\circ}C$
Lead Temperature (Soldering, 10 sec)	$300^{\circ}C$

PACKAGE/ORDER INFORMATION

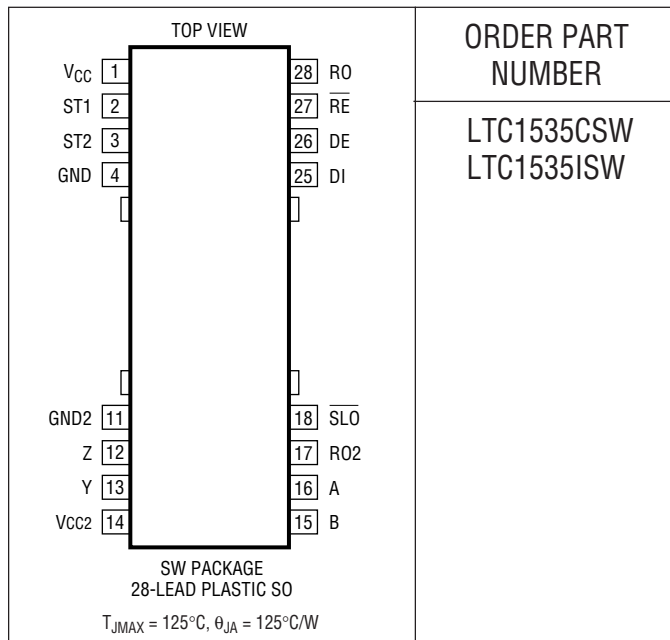

ORDER PART
NUMBER

LTC1535CSW
LTC1535ISW

Consult factory for Military grade parts.

ELECTRICAL CHARACTERISTICS

The ● denotes the specifications which apply over the full operating temperature range, otherwise specifications are at $T_A = 25^{\circ}C$. $V_{CC} = 5V$, $V_{CC2} = 5V$ unless otherwise noted.

SYMBOL	PARAMETER	CONDITIONS	MIN	TYP	MAX	UNITS	
V_{CC}	V_{CC} Supply Range		● 4.5		5.5	V	
V_{CC2}	V_{CC2} Supply Range		● 4.5		7.5	V	
I_{CC}	V_{CC} Supply Current	Transformer Not Driven (Note 10)	●	13	28	mA	
I_{CC2}	V_{CC2} Supply Current	$R = 27\Omega$, Figure 2	●	63	73	mA	
		No Load	●	7	12	mA	
V_{OD1}	Differential Driver Output	No Load	●		5	V	
V_{OD2}	Differential Driver Output	$R = 50\Omega$ (RS422) (Note 2), $V_{CC2} = 4.5V$	●	2		V	
		$R = 27\Omega$ (RS485), Figure 2, $V_{CC2} = 4.5V$	●	1.5	2	V	
V_{OC}	Driver Output Common Mode Voltage	DC Level, $R = 50\Omega$, Figure 2	●	2.0	2.5	3.0	V
I_{OSD1}	Driver Short-Circuit Current $V_{OUT} = HIGH$ $V_{OUT} = LOW$	Driver Enabled (DE = 1)	●	60	100	150	mA
		$-7V \leq V_{CM} \leq 10V$ $-7V \leq V_{CM} \leq 10V$	●	60	100	150	mA
V_{IH}	Logic Input High Voltage	DE, DI, RE	●	2	1.7		V
		SLO	●	4	2.2		V
V_{IL}	Logic Input Low Voltage	DE, DI, RE	●		1.7	0.8	V
		SLO	●		1.8	1	V
I_{IN}	Input Current (A, B)	(Note 3)			0.25	mA	
		$V_{IN} = 12V$ $V_{IN} = -7V$	●			-0.20	mA
V_{TH}	Receiver Input Threshold	$-7V \leq V_{CM} \leq 12V$, (Note 4)	●	-200	-90	-10	mV
ΔV_{TH}	Receiver Input Hysteresis	$-7V \leq V_{CM} \leq 12V$					
		$0^{\circ}C \leq T_A \leq 0^{\circ}C$ $-40^{\circ}C \leq T_A \leq 85^{\circ}C$	●	10	30	70	mV
R_{IN}	Receiver Input Impedance		●	50	68	85	k Ω

ELECTRICAL CHARACTERISTICS

The ● denotes the specifications which apply over the full operating temperature range, otherwise specifications are at $T_A = 25^\circ\text{C}$. $V_{CC} = 5\text{V}$, $V_{CC2} = 5\text{V}$ unless otherwise noted.

SYMBOL	PARAMETER	CONDITIONS	MIN	TYP	MAX	UNITS
V_{IOC}	Receiver Input Open Circuit Voltage			3.4		V
V_{OH}	RO Output High Voltage	$I_{RO} = -4\text{mA}$, $V_{CC} = 4.5\text{V}$	● 3.7	4.0		V
V_{OL}	RO Output Low Voltage	$I_{RO} = 4\text{mA}$, $V_{CC} = 4.5\text{V}$	●	0.4	0.8	V
I_{OZ}	Driver Output Leakage	Driver Disabled ($DE = 0$)		1		μA
V_{OH2}	RO2 Output High Voltage	$I_{RO2} = -4\text{mA}$, $V_{CC} = 4.5\text{V}$	● 3.7	3.9		V
V_{OL2}	RO2 Output Low Voltage	$I_{RO2} = 4\text{mA}$, $V_{CC} = 4.5\text{V}$	●	0.4	0.8	V
f_{SW}	DC Converter Frequency		● 290	420	590	kHz
R_{SWH}	DC Converter Impedance High		●	4	6	Ω
R_{SWL}	DC Converter Impedance Low		●	2.5	5	Ω
I_{REL}	\overline{RE} Output Low Current	\overline{RE} Sink Current, Fault = 0	● -40	-50	-80	μA
I_{REH}	\overline{RE} Output High Current	\overline{RE} Source Current, Fault = 1	● 80	100	130	μA
V_{UVL}	Undervoltage Low Threshold	\overline{RE} Fault = 1, (Note 5)	● 3.90	4.00	4.25	V
V_{UVH}	Undervoltage High Threshold	\overline{RE} Fault = 0, (Note 5)	● 4.05	4.20	4.40	V
V_{ISO}	Isolation Voltage	1 Minute, (Note 6) 1 Second	2500 3000			V_{RMS} V_{RMS}

SWITCHING CHARACTERISTICS

The ● denotes the specifications which apply over the full operating temperature range, otherwise specifications are at $T_A = 25^\circ\text{C}$. $V_{CC} = 5\text{V}$, $V_{CC2} = 5\text{V}$, $R = 27\Omega$ (RS485) unless otherwise noted.

SYMBOL	PARAMETER	CONDITIONS	MIN	TYP	MAX	UNITS
t_{SJ}	Data Sample Jitter	Figure 8, (Note 7)	●	250	285	ns
f_{MAX}	Max Baud Rate	Jitter = 10% Max, $\overline{SLO} = 1$, (Note 8)	● 250	410		kBd
t_{PLH}	Driver Input to Output	$DE = 1$, $\overline{SLO} = 1$, Figure 4, Figure 6 $DE = 1$, $\overline{SLO} = 0$, Figure 4, Figure 6	● ●	600 1300	855 1560	ns ns
t_{PHL}	Driver Input to Output	$DE = 1$, $\overline{SLO} = 1$, Figure 4, Figure 6 $DE = 1$, $\overline{SLO} = 0$, Figure 4, Figure 6	● ●	600 1300	855 1560	ns ns
t_r, t_f	Driver Rise or Fall Time	$DE = 1$, $\overline{SLO} = 1$, Figure 4, Figure 6 $DE = 1$, $\overline{SLO} = 0$, $V_{CC} = V_{CC2} = 4.5\text{V}$	● ●	20 500	100 1000	ns ns
t_{ZH}	Driver Enable to Output	$DI = 1$, $\overline{SLO} = 1$, Figure 5, Figure 7	●	1000	1400	ns
t_{ZL}	Driver Enable to Output	$DI = 0$, $\overline{SLO} = 1$, Figure 5, Figure 7	●	1000	1400	ns
t_{LZ}	Driver Disable to Output	$DI = 0$, $\overline{SLO} = 1$, Figure 5, Figure 7	●	700	1300	ns
t_{HZ}	Driver Disable to Output	$DI = 1$, $\overline{SLO} = 1$, Figure 5, Figure 7	●	700	1300	ns
t_{PLH}	Receiver Input to RO	$\overline{RE} = 0$, Figure 3, Figure 8	●	600	855	ns
t_{PHL}	Receiver Input to RO	$\overline{RE} = 0$, Figure 3, Figure 8	●	600	855	ns
t_{PLH}	Receiver Input to RO2	$\overline{RE} = 0$, Figure 3, Figure 8		30		ns
t_{PHL}	Receiver Input to RO2	$\overline{RE} = 0$, Figure 3, Figure 8		30		ns
t_r, t_f	Receiver Rise or Fall Time	$\overline{RE} = 0$, Figure 3, Figure 8		20		ns
t_{LZ}	Receiver Disable to Output	Figure 3, Figure 9		30		ns
t_{HZ}	Receiver Disable to Output	Figure 3, Figure 9		30		ns
t_{START}	Initial Start-Up Time	(Note 9)		1200		ns
t_{TOF}	Data Time-Out Fault	(Note 9)		1200		ns
	ST1, ST2 Duty Cycle	$0^\circ\text{C} \leq T_A \leq 70^\circ\text{C}$ $-40^\circ\text{C} \leq T_A \leq 85^\circ\text{C}$	● ●		56 57	% %

ELECTRICAL CHARACTERISTICS

Note 1: Absolute Maximum Ratings are those values beyond which the life of a device may be impaired.

Note 2: RS422 50Ω specification based on RS485 27Ω test.

Note 3: I_{IN} is tested at $V_{CC2} = 5V$, guaranteed by design from $GND2 \leq V_{CC2} \leq 5.25V$.

Note 4: Input fault conditions on the RS485 receiver are detected with a fixed receiver offset. The offset is such that an input short or open will result in a high data output.

Note 5: The low voltage detect faults when V_{CC2} or V_{CC} drops below V_{UVL} and reenables when greater than V_{UVH} . The fault can be monitored through the weak driver output on RE.

Note 6: Value derived from 1 second test.

Note 7: The input signals are internally sampled and encoded. The internal sample rate determines the data output jitter since the internal sampling is asynchronous with respect to the external data. Nominally, a 4MHz internal sample rate gives 250ns of sampling uncertainty in the input signals.

Note 8: The maximum baud rate is 250kBd with 10% sampling jitter. Lower baud rates have lower jitter.

Note 9: Start-up time is the time for communication to recover after a fault condition. Data time-out is the time a fault is indicated on RE after data communication has stopped.

Note 10: I_{CC} measured with no load, ST1 and ST2 floating.

TYPICAL PERFORMANCE CHARACTERISTICS

V_{CC} Supply Current vs Temperature

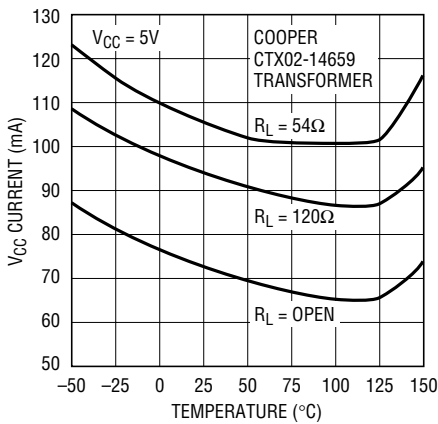

1535 G01

V_{CC2} Supply Current vs Temperature

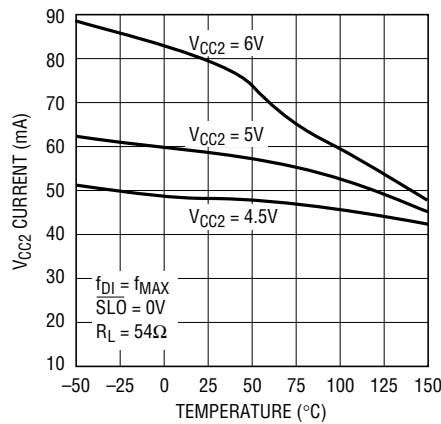

1535 G02

V_{CC2} Supply Voltage vs Temperature

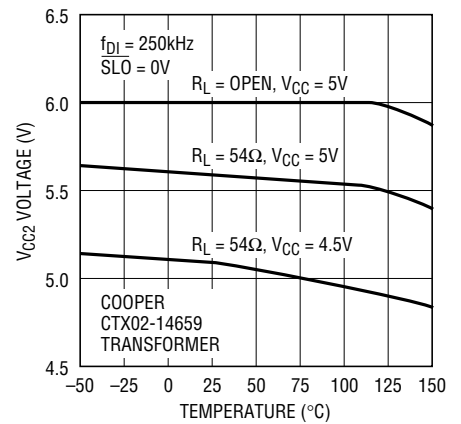

1535 G03

Maximum Baud Rate vs Temperature

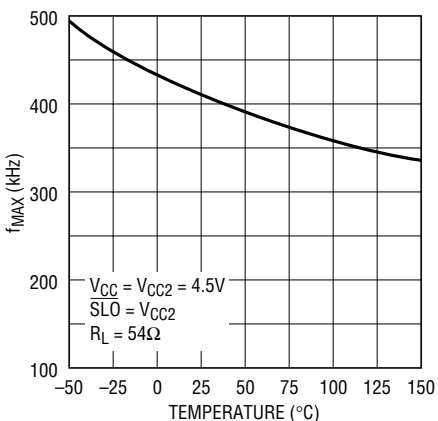

1535 G04

Driver Differential Output Rise/Fall Time vs Temperature

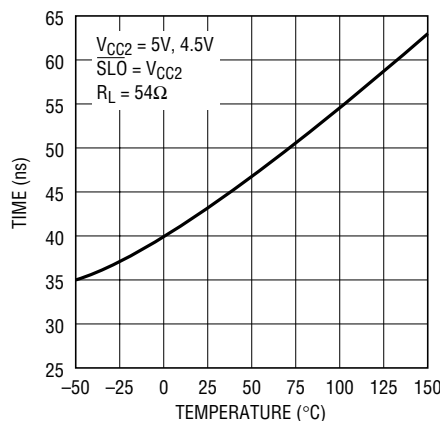

1535 G05

Driver Differential Output Rise/Fall Time vs Temperature

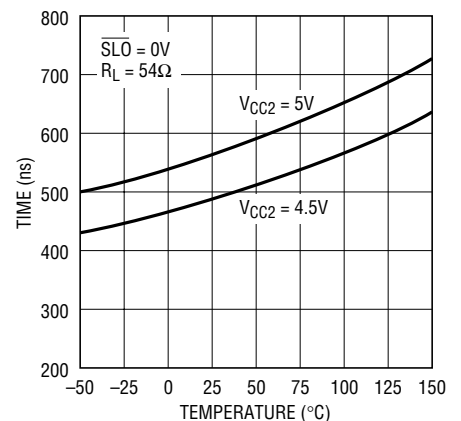

1535 G06

TYPICAL PERFORMANCE CHARACTERISTICS

Switcher Frequency vs Temperature

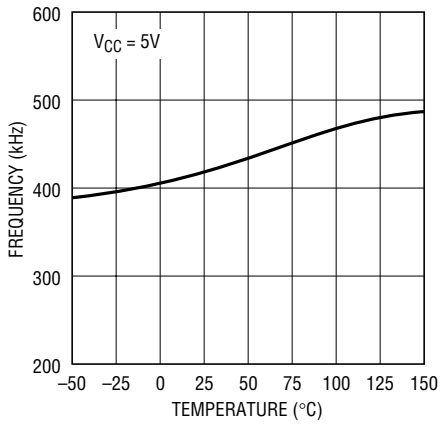

1535 G07

Driver Differential Output Voltage vs Temperature

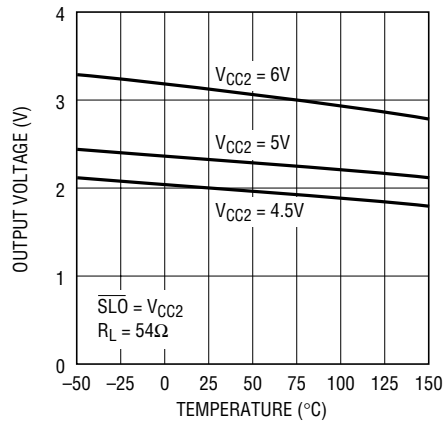

1535 G08

Receiver Output Low Voltage vs Temperature

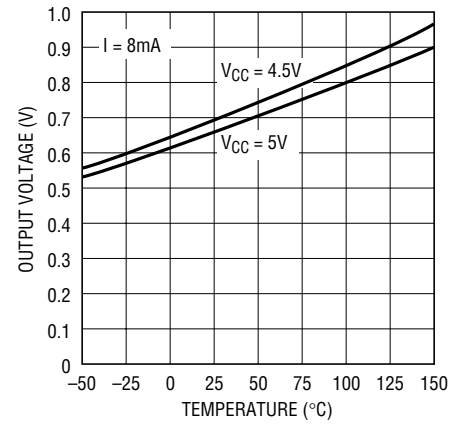

1535 G09

Receiver Output High Voltage vs Temperature

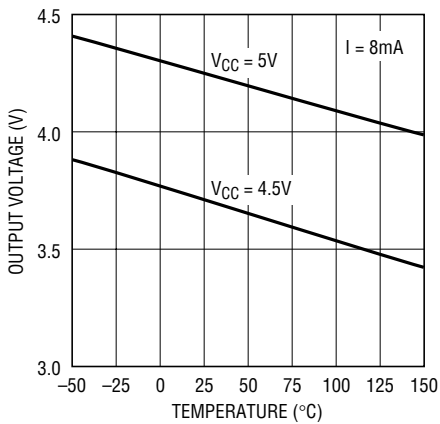

1535 G10

Driver Differential Output Voltage vs Output Current

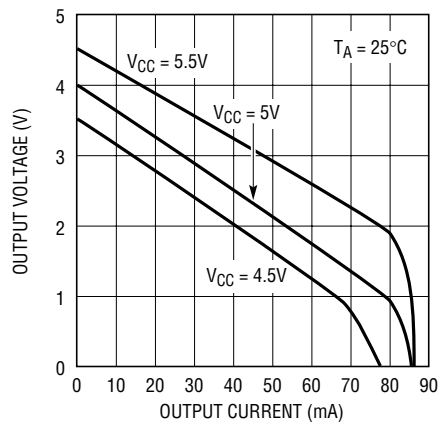

1535 G11

Driver Output High Voltage vs Output Current

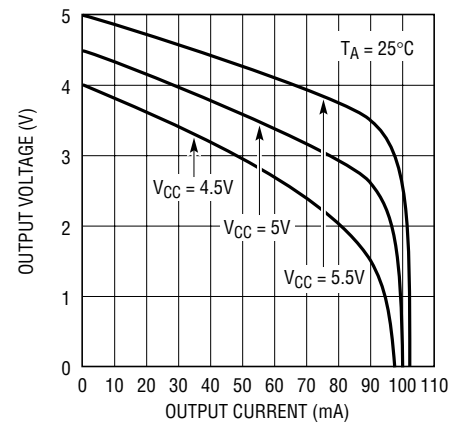

1535 G12

Driver Output Low Voltage vs Output Current

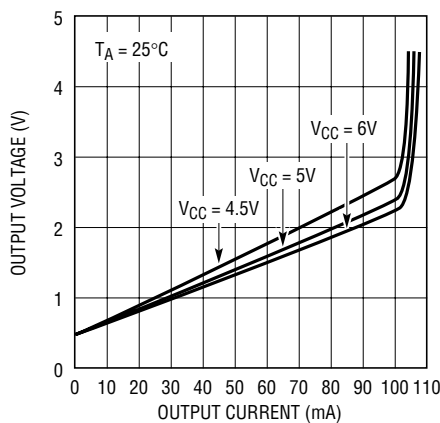

1535 G13

Driver Differential Output Voltage vs VCC2 Supply Voltage

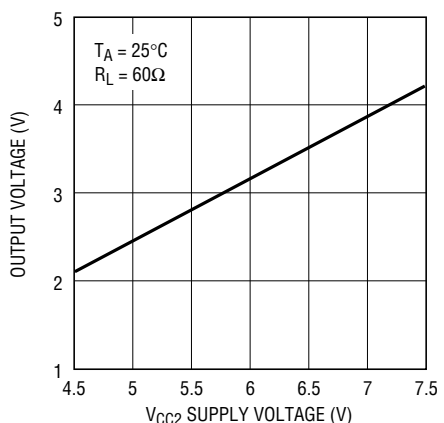

1535 G14

Receiver Output Voltage vs Load Current

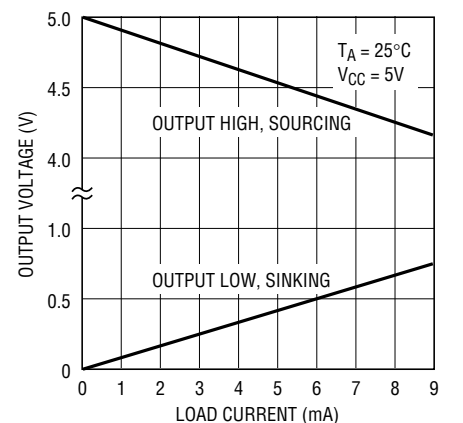

1535 G15

SWITCHING TIME WAVEFORMS

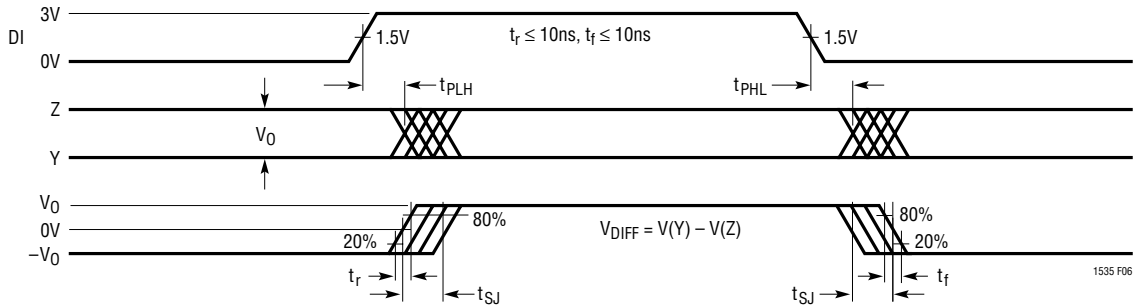

Figure 6. Driver Propagation Delays

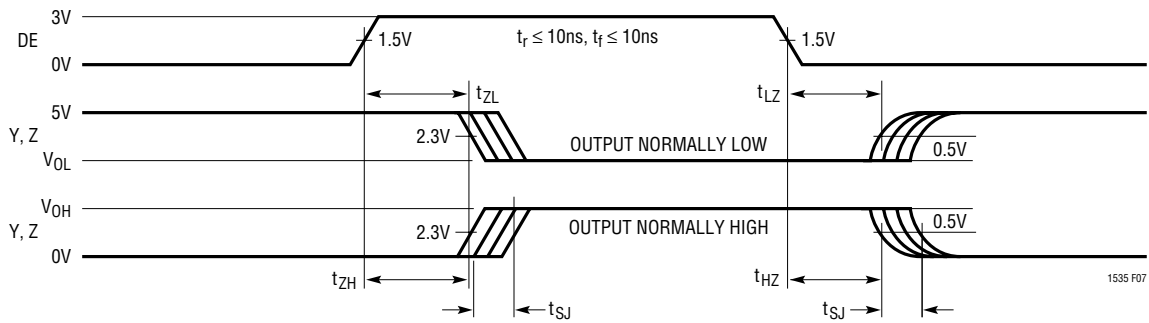

Figure 7. Driver Enable and Disable Times

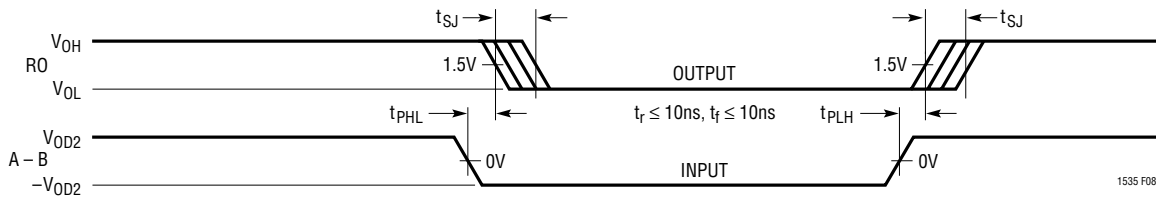

Figure 8. Receiver Propagation Delays

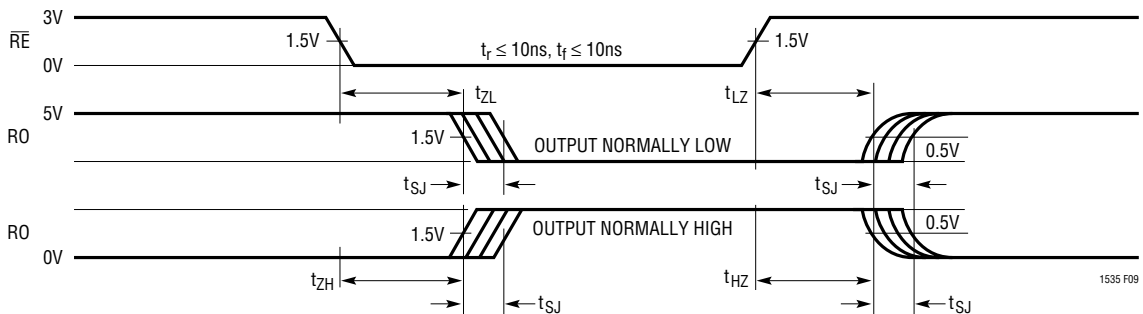

Figure 9. Receiver Enable and Disable Times

APPLICATIONS INFORMATION

Isolation Barrier and Sampled Communication

The LTC1535 uses the SW-28 isolated lead frame package to provide capacitive isolation barrier between the logic interface and the RS485 driver/receiver pair. The barrier provides 2500V_{RMS} of isolation. Communication between the two sides uses the isolation capacitors in a multiplexed way to communicate full-duplex data across this barrier (see Figure 20 and Block Diagram). The data is sampled and encoded before transmitting across the isolation barrier, which will add sampling jitter and delay to the signals (see Figures 13 and 14). The sampling jitter is approximately 250ns with a nominal delay of 600ns. At 250kBd rate, this represents 6.2% total jitter. The nominal DE signal to the driver output delay is 875ns ±125ns, which is longer due to the encoding. Communication start-up time is approximately 1μs to 2μs. A time-out fault will occur if communication from the isolated side fails. Faults can be monitored on the \overline{RE} pin.

The maximum baud rate can be determined by connecting in self-oscillation mode as shown in Figure 1. In this configuration, with $\overline{SLO} = V_{CC2}$, the oscillation frequency is set by the internal sample rate. With $\overline{SLO} = 0V$, the frequency is reduced by the slower output rise and fall times.

Push-Pull DC/DC Converter

The powered side contains a full-bridge open-loop driver, optimized for use with a single primary and center-tapped secondary transformer. Figure 10 shows the DC/DC converter in a configuration that can deliver up to 100mA of current to the isolated side using a Cooper CTX02-14659 transformer.

Because the DC/DC converter is open-loop, care in choosing low impedance parts is important for good regulation. Care must also be taken to not exceed the V_{CC2} recommended maximum voltage of 7.5V when there is very light loading. The isolated side contains a low voltage detect circuit to ensure that communication across the barrier will only occur when there is sufficient isolated supply voltage. If the output of the DC/DC converter is overloaded, the supply voltage will trip the low voltage detection at 4.2V. For higher voltage stand-off, the Cooper CTX02-14608 transformer may be used.

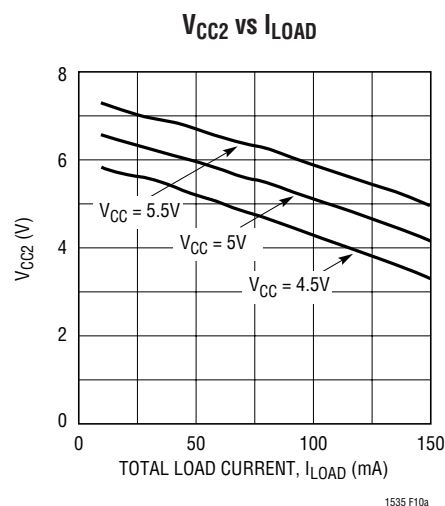
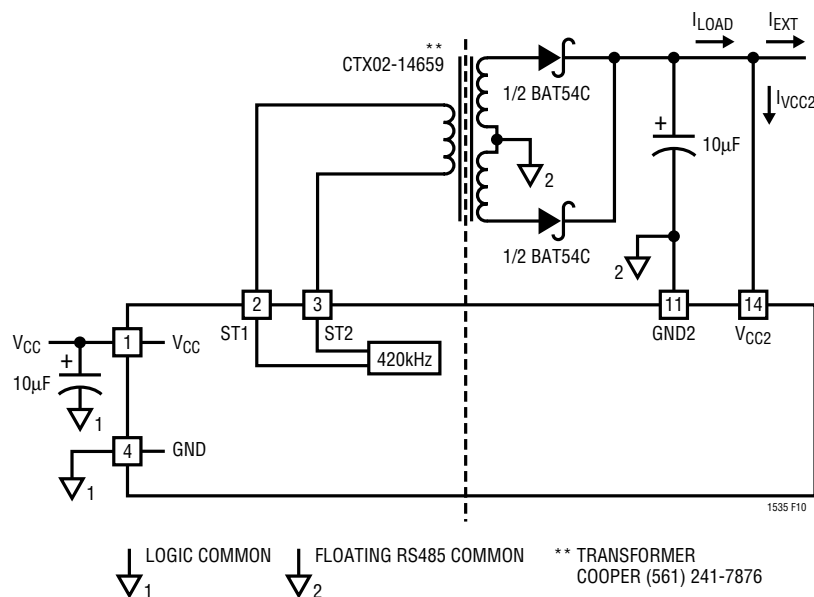

Figure 10

APPLICATIONS INFORMATION

Driver Output and Slow Slew Rate Control

The LTC1535 uses a proprietary driver output stage that allows a common mode voltage range that extends beyond the power supplies. Thus, the high impedance state is maintained over the full RS485 common mode range. The output stage provides 100mA of short-circuit current limiting in both the positive and negative directions. Thus, even under short-circuit conditions, the supply voltage from the open-loop DC converter will remain high enough for proper communication across the isolation barrier. The driver output will be disabled in the event of a thermal shutdown and a fault condition will be indicated through the \overline{RE} weak output.

The CMOS level \overline{SLO} pin selects slow or fast slew rates on the RS485 driver output (see Figures 15, 16, 17, 18 for typical waveforms). The \overline{SLO} input has an internal 100k pull-up resistor. When \overline{SLO} is low, the driver outputs are slew rate limited to reduce high frequency edges. Left open or tied high, \overline{SLO} defaults to fast edges. The part draws more current during slow slew rate edges.

Monitoring Faults on \overline{RE}

The \overline{RE} pin can be used to monitor the following fault conditions: low supply voltages, thermal shutdown or a time-out fault when there is no data communication across the barrier. During a fault, the receiver output, RO, defaults to a high state (see Table 2). Open circuit or short-circuit conditions on the twisted pair do not cause a fault indication. However, the RS485 receiver defaults to a high output state when the receiver input is open or short-circuited.

The \overline{RE} pin has a weak current drive output mode for indicating fault conditions. This fault state can be polled using a bidirectional microcontroller I/O line or by using the circuit in Figure 11, where the control to \overline{RE} is three-stated and the fault condition read back from the \overline{RE} pin. The weak drive has 100 μ A pull-up current to indicate a fault and 50 μ A pull-down current for no fault. This allows the \overline{RE} pin to be polled without disabling \overline{RE} on nonfault conditions.

Both sides contain a low voltage detect circuit. A voltage less than 4.2V on the isolated side disables communication.

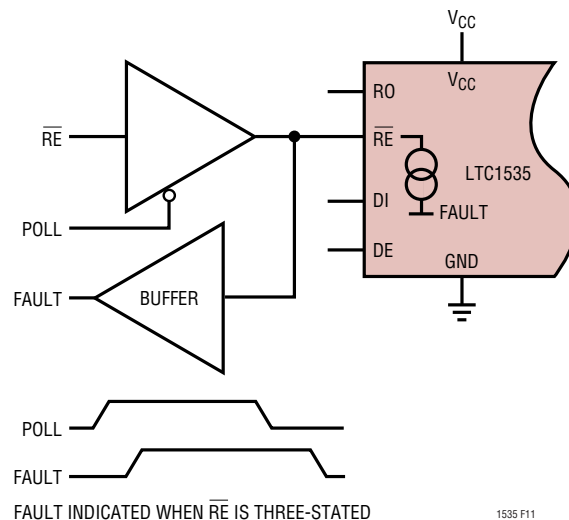

Figure 11. Detecting Fault Conditions

APPLICATIONS INFORMATION

Table 1. List of Transformers Designed for LTC1535

MANUFACTURER	PART NUMBER	DC ISOLATION VOLTAGE (1 Second)	PHONE NUMBER
Cooper	CTX02-14659	500V	(561) 241-7876
Cooper	CTX02-14608	3.75kVAC	(561) 241-7876
Epcos AG (Germany) (USA)	B78304-A1477-A3	500V	(0 89) 636-2 80 00 (800) 888-7724
Midcom	31160R	1.25kV	(605) 886-4385
Pulse FEE (France)	P1597	500V	(33) 3 84 35 04 04
Sumida (Japan)	S-167-5779	100V	03-3667-3320
Transpower	TTI7780-SM	500V	(775) 852-0145

Table 2. Fault Mode Behavior

FUNCTION (PINS)	$V_{CC} > V_{UVH}$ $V_{CC2} > V_{UVH}$	$V_{CC} < V_{UVL}$ $V_{CC2} > V_{UVH}$	$V_{CC} > V_{UVH}$ $V_{CC2} < V_{UVL}$	$V_{CC} < V_{UVL}$ $V_{CC2} > V_{UVL}$	THERMAL SHUTDOWN
DC/DC Converter (2, 3)	On	On	On	On	Off
RO (28)	$\overline{RE} = 0V$	Active	Forced High	Forced High	Forced High
	$\overline{RE} = V_{CC}$	Hi-Z	Hi-Z	Hi-Z	Hi-Z
	$\overline{RE} = \text{Floating}$	Active	Hi-Z	Hi-Z	Hi-Z
RO2 (17)	Active	Active	Active	Active	Active
Driver Outputs Y and Z (13,12)	Active	Hi-Z	Hi-Z	Hi-Z	Hi-Z
Communication Across Isolation Barrier	Active	Disabled	Disabled	Disabled	Disabled
Fault Indicator on \overline{RE} (27)	Low	High	High	High	High

Table 3. Driver Function Table

INPUTS			OUTPUTS	
\overline{RE}	DE	DI	A	B
X	1	1	1	0
X	1	0	0	1
X	0	X	Z	Z

Note: Z = high impedance, X = don't care

Table 4. Receiver Function Table

INPUTS			OUTPUTS	
\overline{RE}	DE	A-B	RO	RO2
0	X	$\geq V_{TH(MAX)}$	1	1
0	X	$\leq V_{TH(MIN)}$	0	0
0	X	Inputs Open	1	1
0	X	Inputs Shorted	1	1
1	X	$\geq V_{TH(MAX)}$	Z	1
1	X	$\leq V_{TH(MIN)}$	Z	0
1	X	Inputs Open	Z	1
1	X	Inputs Shorted	Z	1

Note: Z = high impedance, X = don't care

APPLICATIONS INFORMATION

High Voltage Considerations

The LTC1535 eliminates ground loops on data communication lines. However, such isolation can bring potentially dangerous voltages onto the circuit board. An example would be accidental faulting to 117V AC at some point on the cable which is then conducted to the PC board. Figure 12 shows how to detect and warn the user or installer that a voltage fault condition exists on the twisted pair or its shield. A small (3.2mm) glow lamp is connected between GND2 (the isolated ground) and the equipment's safety "earth" ground. If a potential of more than 75V AC is present on the twisted pair or shield, B1 will light, indicating a wiring fault. Resistors R3 and R4 are used to ballast the current in B1. Two resistors are necessary because they can only stand off 200V each, as well as for power dissipation. As shown, the circuit can withstand a direct fault to a 440V 3Ø system.

Other problems introduced by floating the twisted pair include the collection of static charge on the twisted pair, its shield and the attached circuitry. Resistors R1 and R2

provide a path to shunt static charge safely to ground. Again, two resistors are necessary to withstand high voltage faults. Electrostatic spikes, electromagnetically induced transients and radio frequency pickup are shunted by addition capacitor C1.

Receiver Inputs Fail-Safe

The LTC1535 features an input common mode range covering the entire RS485 specified range of -7V to 12V. Differential signals of greater than $\pm 200\text{mV}$ within the specified input common mode range will be converted to TTL compatible signals at the receiver outputs, RO and RO2. A small amount of input hysteresis is included to minimize the effects of noise on the line signals. If the receiver inputs are floating or shorted, a designed-in receiver offset guarantees a fail-safe logic high at the receiver outputs. If a fail-safe logic low is desired, connect as shown in Figure 19.

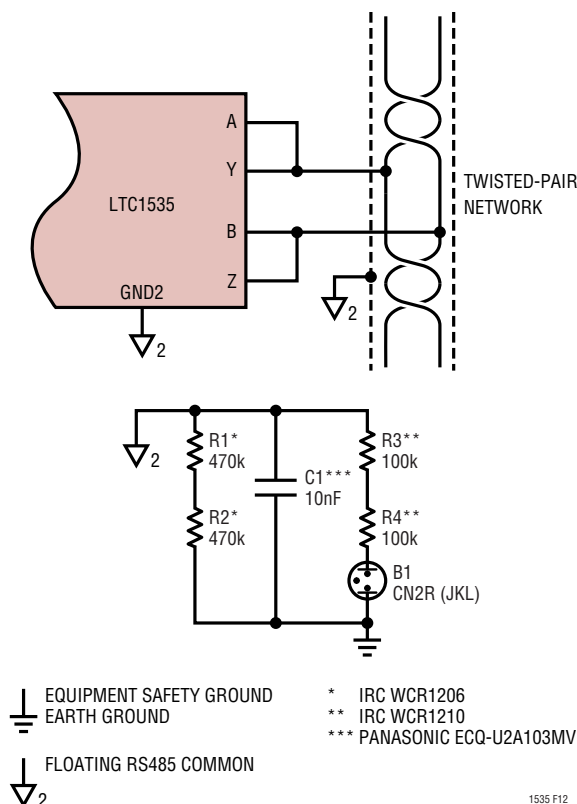

Figure 12. Detecting Wiring Faults

APPLICATIONS INFORMATION

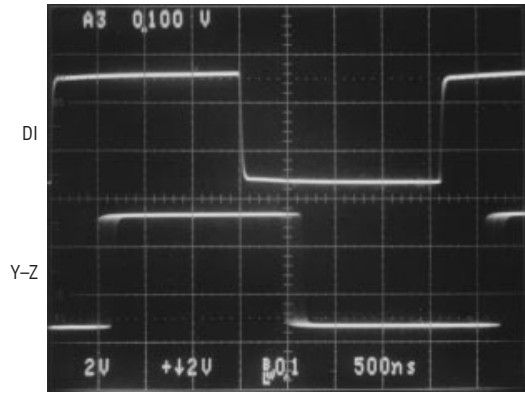

Figure 13. Driver Propagation Delay with Sample Jitter. $SLO = V_{CC2}$

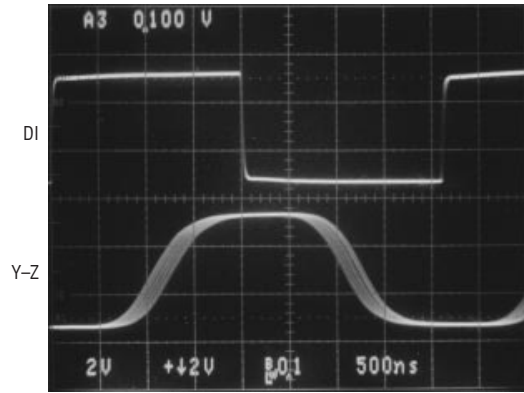

Figure 14. Driver Propagation Delay with Sample Jitter. $SLO = 0V$

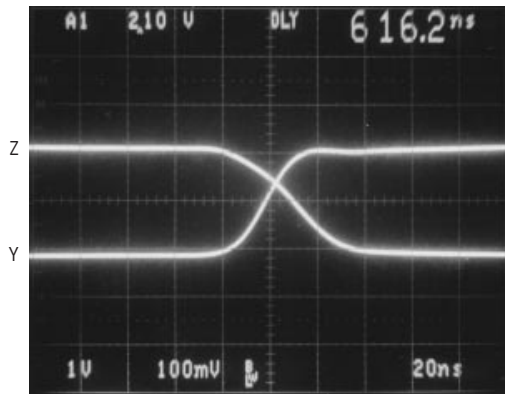

Figure 15. Driver Output. $R = 27\Omega$, $V_{CC2} = 5V$, $SLO = V_{CC2}$

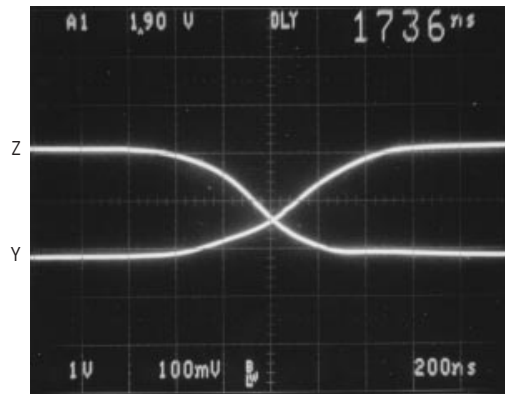

Figure 16. Driver Output. $R = 27\Omega$, $V_{CC2} = 5V$, $SLO = 0V$

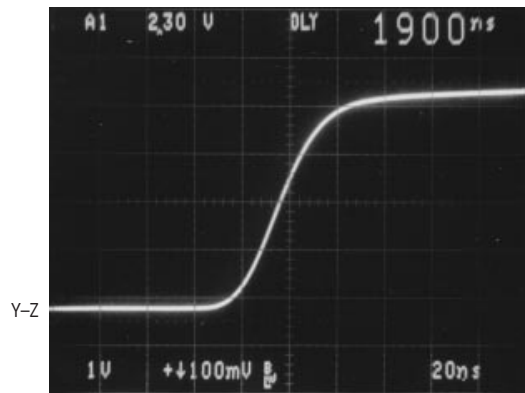

Figure 17. Driver Differential Output. $R = 27\Omega$, $V_{CC2} = 5V$, $SLO = V_{CC2}$

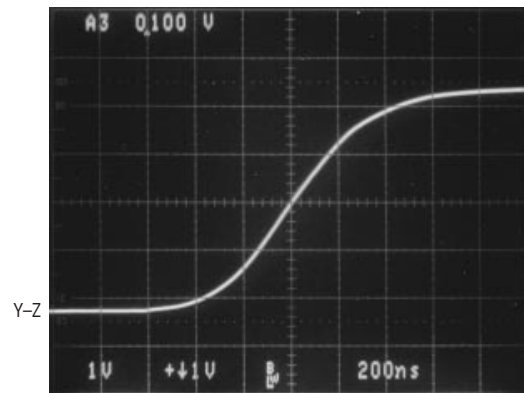

Figure 18. Driver Differential Output. $R = 27\Omega$, $V_{CC2} = 5V$, $SLO = 0V$

LTC1535

TYPICAL APPLICATIONS

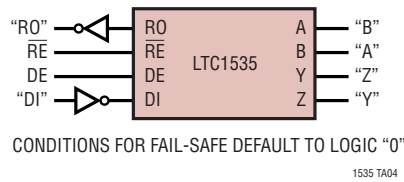

Figure 19. Fail-Safe Logic "0"

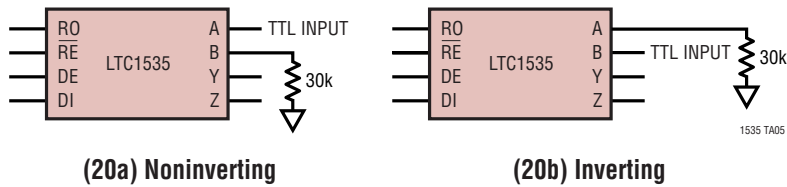
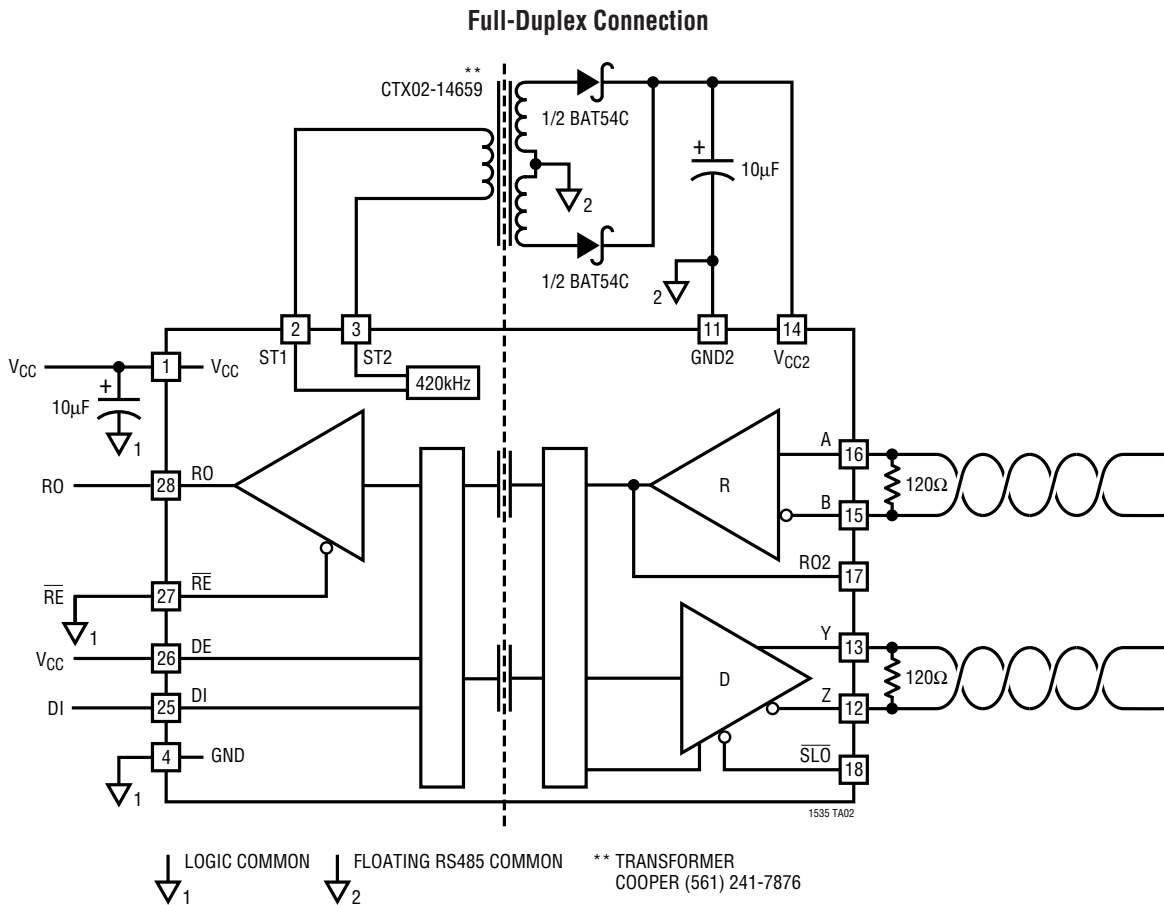
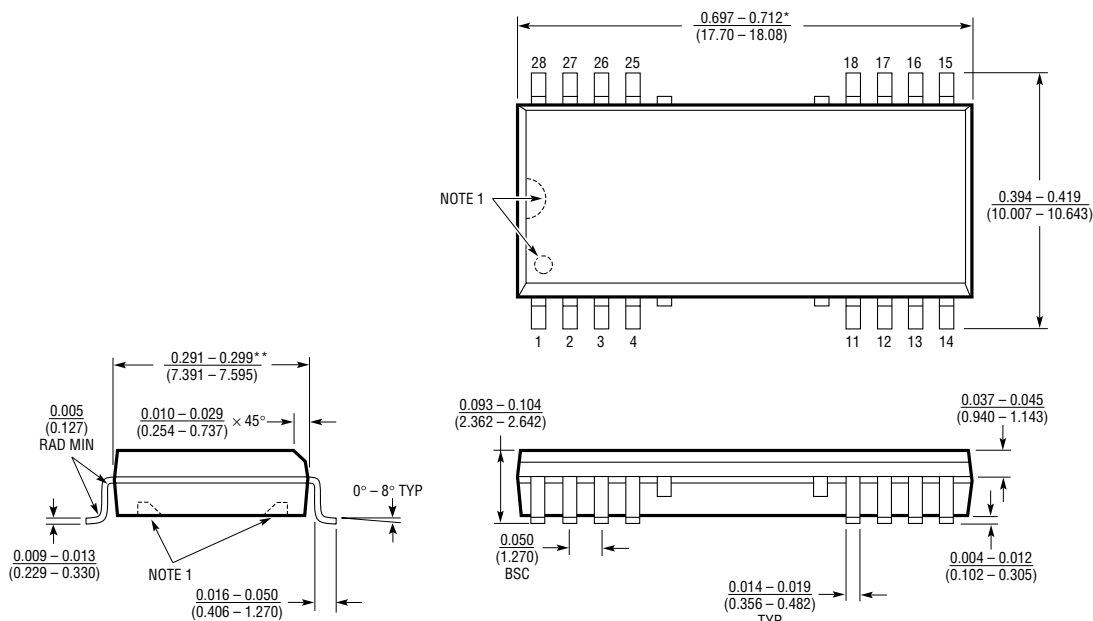

Figure 20. Configuring Receiver for TTL Level Input. Y and Z Outputs Are TTL Compatible with No Modification



PACKAGE DESCRIPTION Dimensions in inches (millimeters) unless otherwise noted.

SW Package
28-Lead Plastic Small Outline Isolation Barrier (Wide 0.300)
 (LTC DWG # 05-08-1690)



NOTE:
 1. PIN 1 IDENT, NOTCH ON TOP AND CAVITIES ON THE BOTTOM OF PACKAGES ARE THE MANUFACTURING OPTIONS
 THE PART MAY BE SUPPLIED WITH OR WITHOUT ANY OF THE OPTIONS.
 *DIMENSION DOES NOT INCLUDE MOLD FLASH. MOLD FLASH SHALL NOT EXCEED 0.006" (0.152mm) PER SIDE
 **DIMENSION DOES NOT INCLUDE INTERLEAD FLASH. INTERLEAD FLASH SHALL NOT EXCEED 0.010" (0.254mm) PER SIDE

SW28 (ISO) 1098

