



500mA High Efficiency, Low Noise, Inductorless Step-Down DC/DC Converter

FEATURES

- 500mA Output Current
- No Inductors
- 2.7V to 5.5V Input Voltage Range
- Typical Efficiency 50% Higher Than LDOs
- 2-Phase, Spread Spectrum Operation for Low Input and Output Noise
- Shutdown Disconnects Load from V_{IN}
- Adjustable Output Voltage Range: 0.9V to 1.6V
- Super Burst, Burst and Burst Defeat Operation
- Low Operating Current: $I_{IN} = 35\mu A$ (Burst Mode[®] Operation)
- Super Burst Operating Current: $I_{IN} = 8\mu A$
- Low Shutdown Current: $I_{IN} = 0.01\mu A$ Typ
- Soft-Start Limits Inrush Current at Turn-On
- Short-Circuit and Overtemperature Protected
- Available in a Thermally Enhanced 10-Pin MSOP Package

APPLICATIONS

- Handheld Devices
- Cellular Phones
- Portable Electronic Equipment
- DSP Power Supplies

DESCRIPTION

August 2002

The LTC[®]3251 is a 2-phase charge pump step-down DC/DC converter that produces a regulated output from a 2.7V to 5.5V input. The part uses switched capacitor fractional conversion to achieve a typical efficiency increase of 50% over that of a linear regulator. No inductors are required. V_{OUT} is resistor programmable from 0.9V to 1.6V with up to 500mA of load current

A unique 2-phase spread spectrum architecture provides a very low noise regulated output as well as low noise at the input. The part has four operating modes: Continuous Spread Spectrum, Spread Spectrum with Burst Mode operation, Super Burst[™] mode operation and shutdown.

Low operating current (35 μA in Burst Mode operation, 8 μA in Super Burst mode operation) and low external parts count (five small ceramic capacitors and two resistors) make the LTC3251 ideally suited for space-constrained battery-powered applications. The part is short-circuit and overtemperature protected, and is available in a thermally enhanced 10-pin MSOP package.

LT, LTC and LT are registered trademarks of Linear Technology Corporation.
Burst Mode is a registered trademark of Linear Technology Corporation.
Super Burst is a trademark of Linear Technology Corporation.

TYPICAL APPLICATION

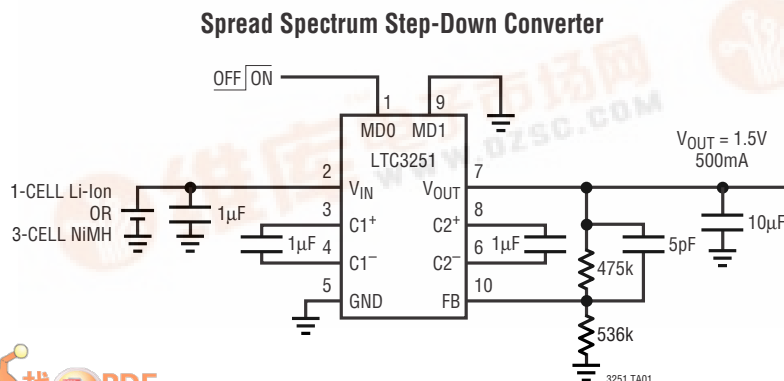

1.5V Efficiency vs Input Voltage
(Burst Mode Operation)

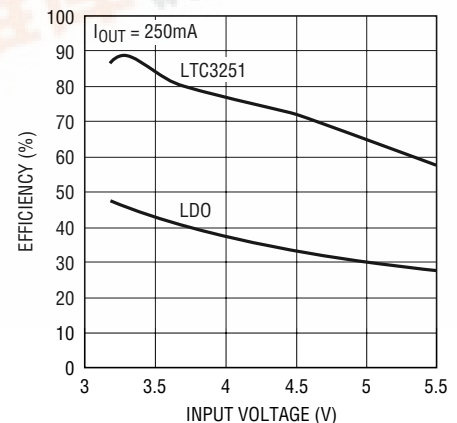

LTC3251

ABSOLUTE MAXIMUM RATINGS

(Note 1)

V_{IN} to GND	-0.3V to 6V
MD0, MD1 and FB to GND	-0.3V to ($V_{IN} + 0.3V$)
I_{OUT} (Note 2)	650mA
Operating Temperature Range (Note 3) ...	-40°C to 85°C
Storage Temperature Range	-65°C to 150°C
Lead Temperature (Soldering, 10 sec)	300°C

PACKAGE/ORDER INFORMATION

<p>MSE PACKAGE 10-LEAD PLASTIC MSOP</p> <p>EXPOSED PAD IS GROUND (MUST BE SOLDERED TO PCB)</p> <p>$T_{JMAX} = 125^{\circ}C$, $\theta_{JA} = 40^{\circ}C/W$</p>	ORDER PART NUMBER
	LTC3251EMSE
	MSE PART MARKING
	LTB4

Consult LTC Marketing for parts specified with wider operating temperature ranges.

ELECTRICAL CHARACTERISTICS

The ● denotes the specifications which apply over the full operating temperature range, otherwise specifications are at $T_A = 25^{\circ}C$. $V_{IN} = 3.6V$, $V_{OUT} = 1.5V$, $C_1 = C_2 = 1\mu F$, $C_{IN} = 1\mu F$, $C_{OUT} = 10\mu F$, all capacitors ceramic, unless otherwise noted.

SYMBOL	PARAMETER	CONDITIONS	MIN	TYP	MAX	UNITS	
	V_{IN} Minimum Operating Voltage	(Note 4)	●	2.7		V	
	V_{IN} Maximum Operating Voltage		●		5.5	V	
	V_{IN} Continuous Mode Operating Current	$I_{OUT} = 0mA$, $V_{MD0} = 0$, $V_{MD1} = V_{IN}$	●	3	5	mA	
	V_{IN} Burst Mode Operating Current	$I_{OUT} = 0mA$, $V_{MD0} = V_{IN}$, $V_{MD1} = 0$	●	35	60	μA	
	V_{IN} Super Burst Mode Operating Current	$I_{OUT} = 0mA$, $V_{MD0} = V_{IN}$, $V_{MD1} = V_{IN}$	●	8	15	μA	
	V_{IN} Shutdown Current	$V_{MD0} = 0V$, $V_{MD1} = 0V$	●	0.01	1	μA	
	V_{FB} Regulation Voltage	$I_{OUT} = 0mA$, $2.7V \leq V_{IN} \leq 5.5V$	●	0.78	0.8	0.82	V
	I_{OUT} Continuous Output Current	$V_{MD0} = 0$, $V_{MD1} = V_{IN}$ or $V_{MD0} = V_{IN}$, $V_{MD1} = 0$	●		500	mA	
	I_{OUT} Super Burst Output Current	$V_{MD0} = V_{IN}$, $V_{MD1} = V_{IN}$	●		40	mA	
	Load Regulation (Referred to FB Pin)	$0mA \leq I_{OUT} \leq 500mA$		0.045		mV/mA	
	Line Regulation (Referred to FB Pin)	$0mA \leq I_{OUT} \leq 500mA$		0.2		%/V	
I_{FB}	FB Input Current	$V_{FB} = 0.85V$	●	-50	50	nA	
	V_R Output Ripple	$I_{OUT} = 500mA$		12		mV _{p-p}	
	Spread Spectrum Frequency Range	f_{MIN} Switching Frequency	●	0.8	1.0	MHz	
		f_{MAX} Switching Frequency	●		1.6	2	MHz
V_{IH}	MD0, MD1 Input High Voltage	$2.7V \leq V_{IN} \leq 5.5V$	●	0.8	1.2	V	
V_{IL}	MD0, MD1 Input Low Voltage	$2.7V \leq V_{IN} \leq 5.5V$	●	0.4	0.8	V	
I_{IH}	MD0, MD1 Input High Current	$MD0 = V_{IN}$, $MD1 = V_{IN}$	●	-1	1	μA	
I_{IL}	MD0, MD1 Input Low Current	$MD0 = 0V$, $MD1 = 0V$	●	-1	1	μA	
t_{ON}	Turn-On Time	$R_{OUT} = 3\Omega$, Burst or Continuous Mode Operation		1		ms	
R_{OL}	Open-Loop Output Impedance	$V_{IN} = 3V$, $I_{OUT} = 200mA$ (Note 5)	●	0.45	0.7	Ω	

Note 1: Absolute Maximum Ratings are those values beyond which the life of a device may be impaired.

Note 2: Based on long term current density limitations.

Note 3: The LTC3251E is guaranteed to meet specified performance from 0°C to 70°C. Specifications over the -40°C to 85°C operating temperature range are assured by design, characterization and correlation with statistical process controls.

Note 4: Minimum operating voltage required for regulation is:

$$V_{IN} \geq 2 \cdot (V_{OUT} + R_{OL} \cdot I_{OUT})$$

Note 5: Output not in regulation; $V_{FB} = 0.76V$, $R_{OL} = (V_{IN}/2 - V_{OUT})/I_{OUT}$.

TYPICAL PERFORMANCE CHARACTERISTICS

No Load Supply Current vs Supply Voltage (Continuous Mode)

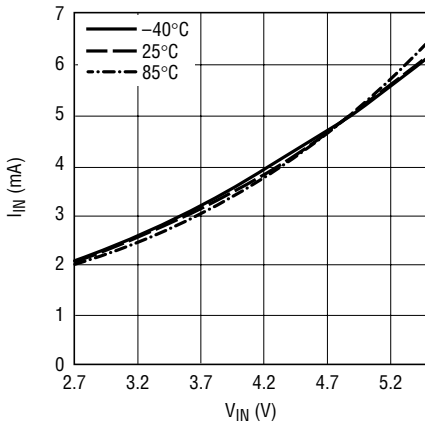

3251 G01

No Load Supply Current vs Supply Voltage (Burst Mode Operation)

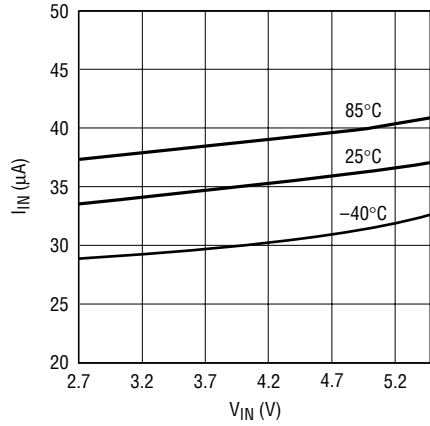

3251 G02

No Load Supply Current vs Supply Voltage (Super Burst Mode Operation)

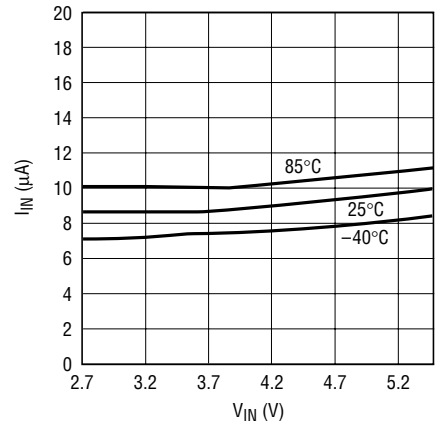

3251 G03

1.5V Output Voltage vs Supply Voltage (Burst Mode Operation/Continuous Mode)

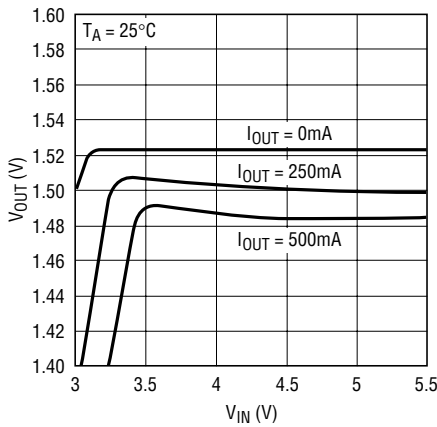

3251 G04

1.2V Output Voltage vs Supply Voltage (Burst Mode Operation/Continuous Mode)

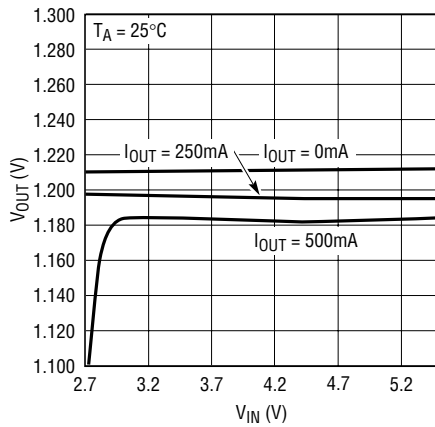

3251 G05

1.5V Output Voltage vs Supply Voltage (Super Burst Mode Operation)

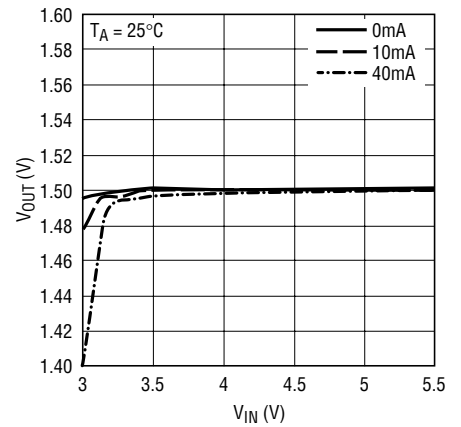

3251 G06

FB Voltage vs Output Current (Burst Mode Operation/Continuous Mode)

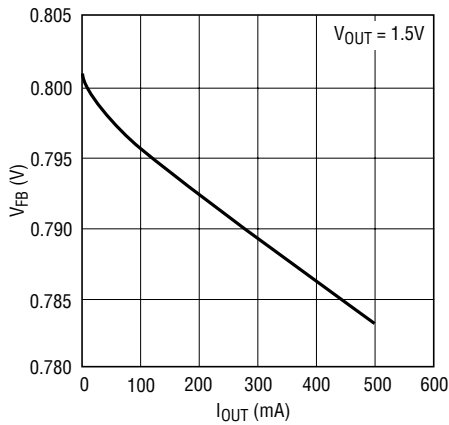

3251 G07

1.5V Output Efficiency vs Output Current (Burst Mode Operation)

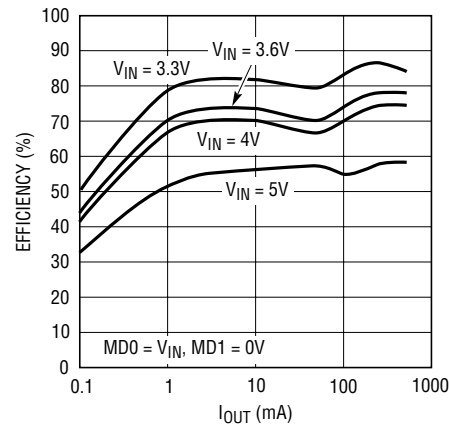

3251 G08

1.5V Output Efficiency vs Output Current (Super Burst Mode Operation)

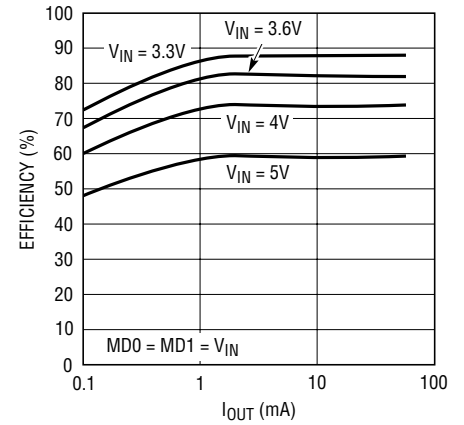

3251 G09

TYPICAL PERFORMANCE CHARACTERISTICS

MD0/MD1 Input Threshold Voltage vs Supply Voltage

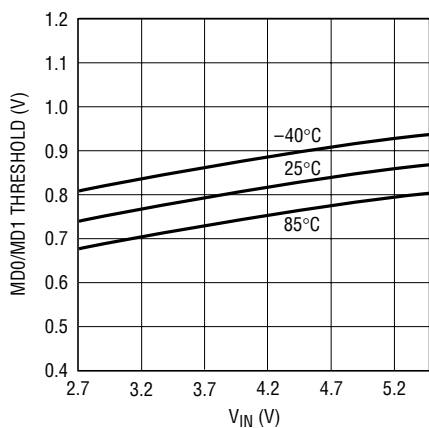

3251 G10

Max/Min Oscillator Frequency vs Supply Voltage

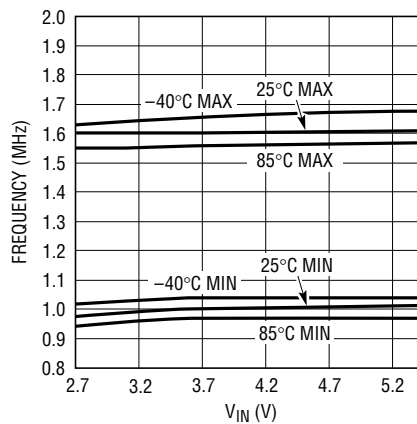

3251 G11

Output Transient Response (Continuous Mode)

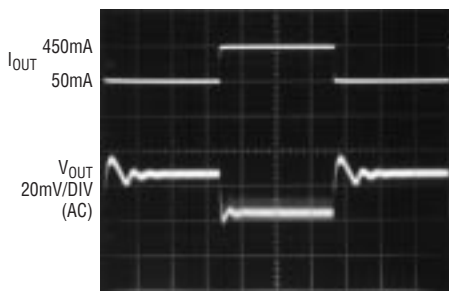

T_A = 25°C 10μs/DIV 3251 G13
 C_{OUT} = 10μF X5R 6.3V
 V_{OUT} = 1.5V

Output Transient Response (Burst Mode Operation)

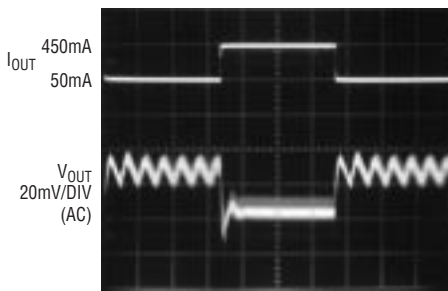

T_A = 25°C 10μs/DIV 3251 G14
 C_{OUT} = 10μF X5R 6.3V
 V_{OUT} = 1.5V

Supply Transient Response (Continuous Mode)

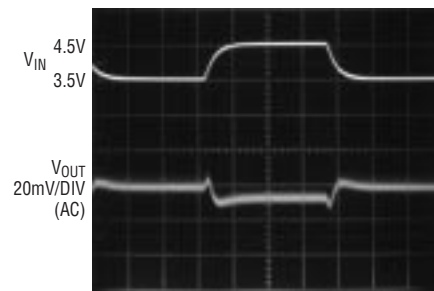

T_A = 25°C 20μs/DIV 3251 G15
 C_{OUT} = 10μF X5R 6.3V
 I_{OUT} = 250mA
 V_{OUT} = 1.5V

PIN FUNCTIONS

MD0 (Pin 1)/MD1 (Pin 9): Mode Input Pins. The Mode input pins are used to set the operating mode of the LTC3251. The modes of operation are:

MD1	MD0	OPERATING MODE
0	0	Shutdown
0	1	Spread Spectrum with Burst
1	0	Continuous Spread Spectrum
1	1	Super Burst

MD0 and MD1 are high impedance CMOS inputs and must not be allowed to float.

V_{IN} (Pin 2): Input Supply Voltage. Operating V_{IN} may be between 2.7V and 5.5V. Bypass V_{IN} with a ≥ 1μF low ESR ceramic capacitor to GND (C_{OUT}).

C1⁺ (Pin 3): Flying Capacitor 1 Positive Terminal (C1).

C1⁻ (Pin 4): Flying Capacitor 1 Negative Terminal (C1).

GND (Pin 5): Ground. Connect to a ground plane for best performance.

C2⁻ (Pin 6): Flying Capacitor 2 Negative Terminal (C2).

PIN FUNCTIONS

V_{OUT} (Pin 7): Regulated Output Voltage. V_{OUT} is disconnected from V_{IN} during shutdown. Bypass V_{OUT} with a low ESR ceramic capacitor to GND (C_{IN}). See V_{OUT} Capacitor Selection for capacitor size requirements.

C2⁺ (Pin 8): Flying Capacitor 2 Positive Terminal (C2).

FB (Pin 10): Feedback Input Pin. An output divider should be connected from V_{OUT} to FB to program the output voltage.

SIMPLIFIED BLOCK DIAGRAM

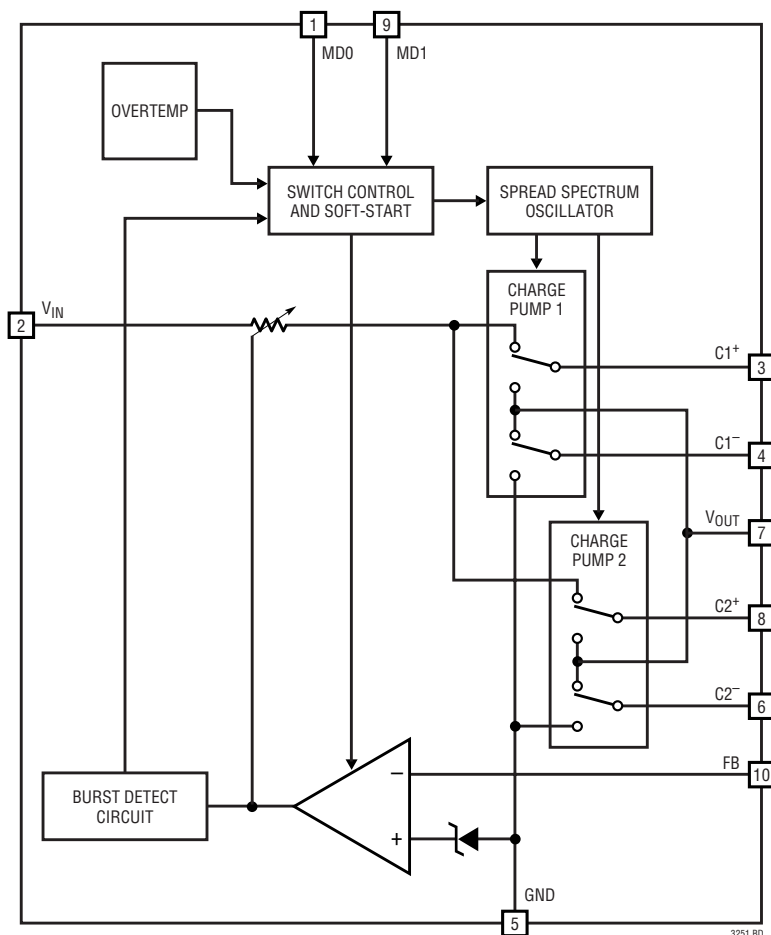

OPERATION (Refer to Block Diagram)

The LTC3251 uses a dual phase switched capacitor charge pump to step down V_{IN} to a regulated output voltage. Regulation is achieved by sensing the output voltage through an external resistor divider and modulating the charge pump output current based on the error signal. A 2-phase nonoverlapping clock activates the two charge

pumps. The two charge pumps work in parallel, but out of phase from each other. On the first phase of the clock, current is transferred from V_{IN}, through the external flying capacitor 1, to V_{OUT} via the switches of Charge Pump 1. Not only is current being delivered to V_{OUT} on the first phase, but the flying capacitor is also being charged. On

OPERATION (Refer to Block Diagram)

the second phase of the clock, flying capacitor 1 is connected from V_{OUT} to ground, transferring the charge stored during the first phase of the clock to V_{OUT} via the switches of Charge Pump 1. Charge Pump 2 operates in the same manner, but with the phases of the clock reversed. This dual phase architecture achieves extremely low output and input noise by providing constant charge transfer from V_{IN} to V_{OUT} .

Using this method of switching, only half of the output current is delivered from V_{IN} , thus achieving a 50% increase in efficiency over a conventional LDO. A spread spectrum oscillator, which utilizes random switching frequencies between 1MHz and 1.6MHz, sets the rate of charging and discharging of the flying capacitors. The part also has two types of low current Burst Mode operation to improve efficiency even at light loads.

In shutdown mode, all circuitry is turned off and the LTC3251 draws only leakage current from the V_{IN} supply. Furthermore, V_{OUT} is disconnected from V_{IN} . The MD0 and MD1 pins are CMOS inputs with threshold voltages of approximately 0.8V to allow regulator control with low voltage logic levels. The LTC3251 is in shutdown when a logic low is applied to both mode pins. Since the mode pins are high impedance CMOS inputs, they should never be allowed to float. Always drive the mode pins with valid logic levels.

Short-Circuit/Thermal Protection

The LTC3251 has built-in short-circuit current limiting as well as overtemperature protection. During short-circuit conditions, internal circuitry automatically limits the output current to approximately 800mA. At higher temperatures, or in cases where internal power dissipation causes excessive self heating on chip (i.e., output short circuit), the thermal shutdown circuitry will shut down the charge pumps when the junction temperature exceeds approximately 160°C. It will reenables the charge pumps once the junction temperature drops back to approximately 150°C. The LTC3251 will cycle in and out of thermal shutdown without latch-up or damage until the overstress condition is removed. Long term overstress ($I_{OUT} > 650\text{mA}$ and/or $T_J > 125^\circ\text{C}$) should be avoided as it can degrade the performance or shorten the life of the part.

Soft-Start

To prevent excessive current flow at V_{IN} during start-up, the LTC3251 has built-in soft-start circuitry. Soft-start is achieved by increasing the amount of current available to the output charge storage capacitor linearly over a period of approximately 500 μs . Soft-start is enabled whenever the device is brought out of shutdown, and is disabled shortly after regulation is achieved.

Spread Spectrum Operation

Switching regulators can be particularly troublesome where electromagnetic interference (EMI) is concerned. Switching regulators operate on a cycle-by-cycle basis to transfer power to an output. In most cases the frequency of operation is either fixed or is a constant based on the output load. This method of conversion creates large components of noise at the frequency of operation (fundamental) and multiples of the operating frequency (harmonics). Figure 1a shows a conventional buck switching converter. Figures 1b and 1c are the input and output noise spectrums for the buck converter of Figure 1 with $V_{IN} = 3.6\text{V}$, $V_{OUT} = 1.5\text{V}$ and $I_{OUT} = 500\text{mA}$.

Unlike conventional buck converters, the LTC3251's internal oscillator is designed to produce a clock pulse whose period is random on a cycle-by-cycle basis, but fixed between 1MHz and 1.6MHz. This has the benefit of spreading the switching noise over a range of frequencies, thus significantly reducing the peak noise. Figures 2b and 2c are the input and output noise spectrums for the LTC3251 of Figure 2a with $V_{IN} = 3.6\text{V}$, $V_{OUT} = 1.5\text{V}$ and $I_{OUT} = 500\text{mA}$. Note the significant reduction in peak output noise (>20dBm) with only 1/2 the output capacitance and the virtual elimination of input harmonics with only 1/10 the input capacitance. Spread spectrum operation is used exclusively in "continuous" mode and for output currents greater than about 50mA in Burst Mode operation.

Low Current Burst Mode Operation

To improve efficiency at low output currents, a Burst Mode function is included in the LTC3251. An output current sense is used to detect when the required output current drops below an internally set threshold (50mA typ). When this occurs, the part shuts down the internal oscillator and

OPERATION (Refer to Block Diagram)

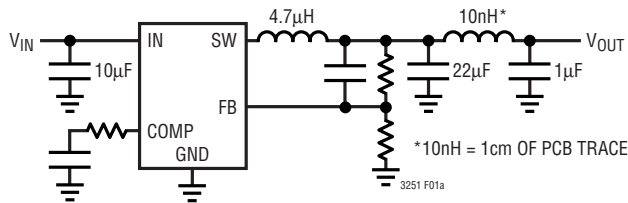

Figure 1a. Conventional Buck Switching Converter

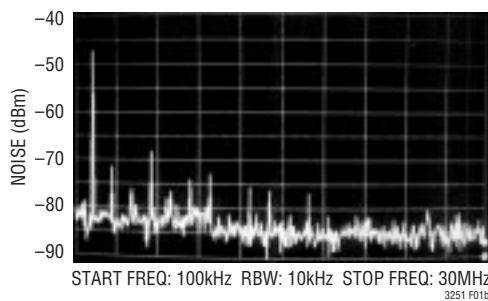

Figure 1b. Conventional Buck Converter Output Noise Spectrum with 22µF Output Capacitor ($I_O = 500\text{mA}$)

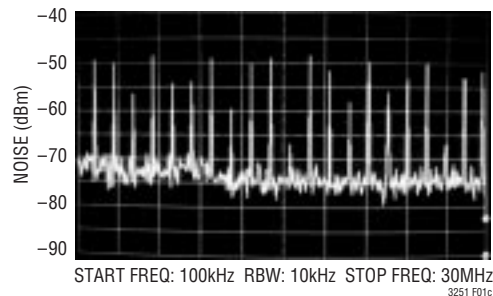

Figure 1c. Conventional Buck Converter Input Noise Spectrum with 10µF Input Capacitor ($I_O = 500\text{mA}$)

goes into a low current operating state. The LTC3251 will remain in the low current operating state until the output voltage has dropped enough to require another burst of current. When the output current exceeds 50mA, the LTC3251 will operate in continuous mode. Unlike traditional charge pumps, where the burst current is dependant on many factors (i.e., supply, switch strength, capacitor selection, etc.), the LTC3251's burst current is set by the burst threshold and hysteresis. This means that the V_{OUT} ripple voltage in Burst Mode operation will be fixed and is typically 15mV with a 10µF output capacitor.

Ultralow Current Super Burst Mode Operation

To further optimize the supply current for low output current requirements, a Super Burst mode operation is

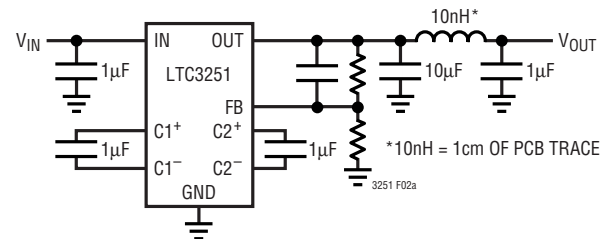

Figure 2a. LTC3251 Buck Converter

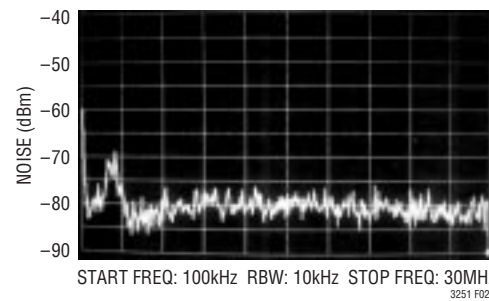

Figure 2b. LTC3251 Output Noise Spectrum with 10µF Output Capacitor ($I_O = 500\text{mA}$)

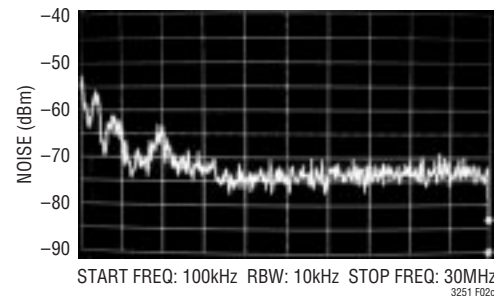

Figure 2c. LTC3251 Input Noise Spectrum with 1µF Input Capacitor ($I_O = 500\text{mA}$)

included in the LTC3251. This mode is very similar to Burst Mode operation, but much of the internal circuitry and switch is shut down to further reduce supply current. In Super Burst mode operation an internal hysteretic comparator connected to the FB pin is used to enable/disable charge transfer. The hysteresis of the comparator and the amount of current deliverable to the output are limited to keep output ripple low. The V_{OUT} ripple voltage in Super Burst mode operation is typically 35mV with a 10µF output capacitor. The LTC3251 can deliver 40mA of current in Super Burst mode operation but does not switch to continuous mode.

V_{OUT} Capacitor Selection

The style and value of capacitors used with the LTC3251

OPERATION (Refer to Block Diagram)

determine several important parameters such as regulator control loop stability, output ripple and charge pump strength.

The dual phase nature of the LTC3251 minimizes output noise significantly but not completely. What small ripple that does exist is controlled by the value of C_{OUT} directly. Increasing the size of C_{OUT} will proportionately reduce the output ripple. The ESR (equivalent series resistance) of C_{OUT} plays the dominant role in output noise. When the LTC3251 switches between clock phases there is a period where all switches are turned off. This “blanking period” shows up as a spike at the output and is a direct function of the output current times the ESR value. To reduce output noise and ripple, it is suggested that a low ESR ($<0.08\Omega$) ceramic capacitor be used for C_{OUT} . Tantalum and aluminum capacitors are not recommended because of their high ESR.

Both the style and value of C_{OUT} can significantly affect the stability of the LTC3251. As shown in the Block Diagram, the LTC3251 uses a control loop to adjust the strength of the charge pump to match the current required at the output. The error signal of this loop is stored directly on the output charge storage capacitor. Thus the charge storage capacitor also serves to form the dominant pole for the control loop. The desired output voltage also affects stability. As the divider ratio (R_A/R_B) drops, the effective closed-loop gain increases, thus requiring a larger output capacitor for stability. Figure 3 shows the suggested output capacitor for optimal transient response. The value of the output capacitance should not drop below the minimum capacitance line to prevent excessive ring-

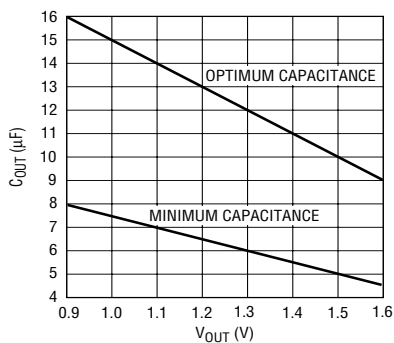

Figure 3

ing or instability. (see Ceramic Capacitor Selection Guidelines section).

Likewise excessive ESR on the output capacitor will tend to degrade the loop stability of the LTC3251. The closed loop output impedance of the LTC3251 is approximately:

$$R_O = 0.045\Omega \cdot \frac{V_{OUT}}{0.8V}$$

For example, with the output programmed to 1.5V, the R_O is 0.085Ω , which produces a 40mV output change for a 500mA load current step. For stability and good load transient response, it is important for the output capacitor to have 0.08Ω or less of ESR. Ceramic capacitors typically have exceptional ESR, and combined with a tight board layout, should yield excellent stability and load transient performance.

Further output noise reduction can be achieved by filtering the LTC3251 output through a very small series inductor as shown in Figure 4. A 10nH inductor will reject the fast output transients caused by the blanking period. The 10nH inductor can be fabricated on the PC board with about 1cm (0.4") of 1mm wide PC board trace.

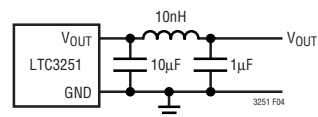

Figure 4. 10nH Inductor Used for Additional Output Noise Reduction

V_{IN} Capacitor Selection

The dual phase architecture used by the LTC3251 makes input noise filtering much less demanding than conventional charge pump regulators. The LTC3251 input current should be continuous at about $I_{OUT}/2$. The blanking period described in the V_{OUT} section also effects the input. For this reason it is recommended that a low ESR, $1\mu F$ ($0.4\mu F$ min) or greater ceramic capacitor be used for C_{IN} (see Ceramic Capacitor Selection Guidelines section).

In cases where the supply impedance is high, heavy output transients can cause significant input transients. These input transients feed back to the output which slows the output transient recovery and increases overshoot. This effect can generally be avoided by using low impedance

OPERATION (Refer to Block Diagram)

supplies and short supply connections. If this is not possible, a $\geq 4.7\mu\text{F}$ capacitor is recommended for the input capacitor. Aluminum and tantalum capacitors are not recommended because of their high ESR.

Further input noise reduction can be achieved by filtering the input through a very small series inductor as shown in Figure 5. A 10nH inductor will reject the fast input transients caused by the blanking period, thereby presenting a nearly constant load to the input supply. For economy, the 10nH inductor can be fabricated on the PC board with about 1cm (0.4") of 1mm wide PC board trace.

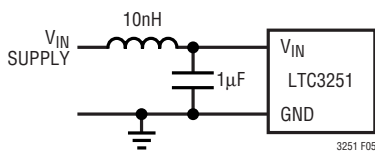

Figure 5. 10nH Inductor Used for Additional Input Noise Reduction

Flying Capacitor Selection

Warning: A polarized capacitor such as tantalum or aluminum should never be used for the flying capacitors since their voltages can reverse upon start-up of the LTC3251. Ceramic capacitors should always be used for the flying capacitors.

The flying capacitors control the strength of the charge pump. In order to achieve the rated output current, it is necessary for the flying capacitor to have at least $0.4\mu\text{F}$ of capacitance over operating temperature with a 2V bias (see Ceramic Capacitor Selection Guidelines). If only 200mA or less of output current is required for the application, the flying capacitor minimum can be reduced to $0.15\mu\text{F}$.

Ceramic Capacitor Selection Guidelines

Capacitors of different materials lose their capacitance with higher temperature and voltage at different rates. For example, a ceramic capacitor made of X5R or X7R material will retain most of its capacitance from -40°C to 85°C , whereas a Z5U or Y5V style capacitor will lose considerable capacitance over that range (60% to 80% loss typ). Z5U and Y5V capacitors may also have a very strong

voltage coefficient, causing them to lose an additional 60% or more of their capacitance when the rated voltage is applied. Therefore, when comparing different capacitors, it is often more appropriate to compare the amount of achievable capacitance for a given case size rather than discussing the specified capacitance value. For example, over rated voltage and temperature conditions, a $4.7\mu\text{F}$, 10V, Y5V ceramic capacitor in an 0805 case may not provide any more capacitance than a $1\mu\text{F}$, 10V, X5R or X7R available in the same 0805 case. In fact, over bias and temperature range, the $1\mu\text{F}$, 10V, X5R or X7R will provide more capacitance than the $4.7\mu\text{F}$, 10V, Y5V. The capacitor manufacturer's data sheet should be consulted to determine what value of capacitor is needed to ensure minimum capacitance values are met over operating temperature and bias voltage.

Below is a list of ceramic capacitor manufacturers and how to contact them:

AVX	www.avxcorp.com
Kemet	www.kemet.com
Murata	www.murata.com
Taiyo Yuden	www.t-yuden.com
Vishay	www.vishay.com

Layout Considerations

Due to the high switching frequency and transient currents produced by the LTC3251, careful board layout is necessary for optimal performance. A true ground plane and short connections to all capacitors will improve performance and ensure proper regulation under all conditions. Figure 6 shows the recommended layout configuration.

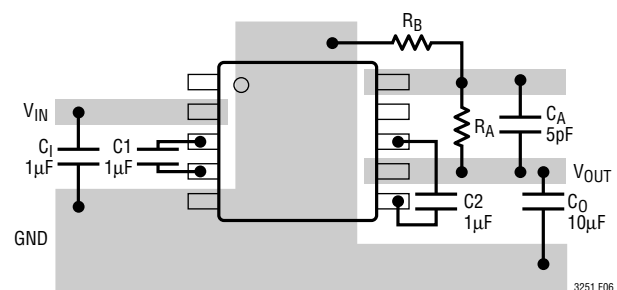

Figure 6. Recommended Layout

LTC3251

OPERATION (Refer to Block Diagram)

The flying capacitor pins C1⁺, C1⁻, C2⁺, C2⁻ will have very high edge rate wave forms. The large dv/dt on these pins can couple energy capacitively to adjacent printed circuit board runs. Magnetic fields can also be generated if the flying capacitors are not close to the LTC3251 (i.e., the loop area is large). To decouple capacitive energy transfer, a Faraday shield may be used. This is a grounded PC trace between the sensitive node and the LTC3251 pins. For a high quality AC ground, it should be returned to a solid ground plane that extends all the way to the LTC3251. Keep the FB trace away from or shielded from the flying capacitor traces or degraded performance could result.

Thermal Management

If the junction temperature increases above approximately 160°C, the thermal shutdown circuitry will automatically deactivate the output. To reduce the maximum junction temperature, a good thermal connection to the PC board is recommended. Connecting the 10-pin MSE paddle directly to a ground plane, and maintaining a solid ground plane under the device on one or more layers of the PC board, can reduce the thermal resistance of the package and PC board considerably. Using this method a θ_{JA} of 40°C/W should be achieved.

Power Efficiency

The power efficiency (η) of the LTC3251 is approximately 50% higher than a conventional linear regulator. This occurs because the input current for a 2-to-1 step-down charge pump is approximately half the output current. For an ideal 2-to-1 step-down charge pump the power efficiency is given by:

$$\eta \equiv \frac{P_{OUT}}{P_{IN}} = \frac{V_{OUT} \cdot I_{OUT}}{V_{IN} \cdot \frac{1}{2} I_{OUT}} = \frac{2V_{OUT}}{V_{IN}}$$

At moderate to high output power the switching losses and quiescent current of the LTC3251 is negligible and the expression above is valid. For example with $V_{IN} = 3.6V$, $I_{OUT} = 200mA$ and V_{OUT} regulating to 1.5V the measured efficiency is 81% which is in close agreement with the theoretical 83.3% calculation.

Programming the LTC3251 Output Voltage (FB Pin)

The LTC3251 is programmed to an arbitrary output voltage via an external resistive divider. Figure 7 shows the required voltage divider connection. The voltage divider ratio is given by the expression:

$$\frac{R_A}{R_B} = \frac{V_{OUT}}{0.8V} - 1$$

Typical values for total voltage divider resistance can range from several k Ω s up to 1M Ω .

The user may want to consider load regulation when setting the desired output voltage. The closed loop output impedance of the LTC3251 is approximately:

$$R_O = 0.045\Omega \cdot \frac{V_{OUT}}{0.8V}$$

For a 1.5V output, R_O is 0.085 Ω , which produces a 40mV output change for a 500mA load current step. Thus, the user may want to target an unloaded output voltage slightly higher than desired to compensate for the output load conditions. The output may be programmed for regulation voltages of 0.9V to 1.6V.

Since the LTC3251 employs a 2-to-1 charge pump architecture, it is not possible to achieve output voltages greater than half the available input voltage. The minimum V_{IN} supply required for regulation can be determined by the following equation:

$$V_{IN(MIN)} \leq 2 \cdot (V_{OUT(MIN)} + I_{OUT} \cdot R_{OL})$$

The compensation capacitor (C_A) is necessary to counteract the pole caused by the large valued resistors R_A and R_B , and the input capacitance of the FB pin. For best results, C_A should be 5pF for all R_A or R_B greater than 10k and can be omitted if both R_A and R_B are less than 10k.

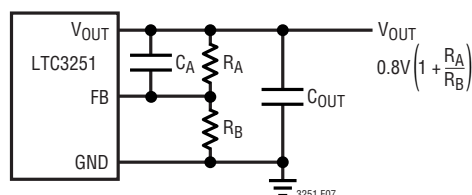
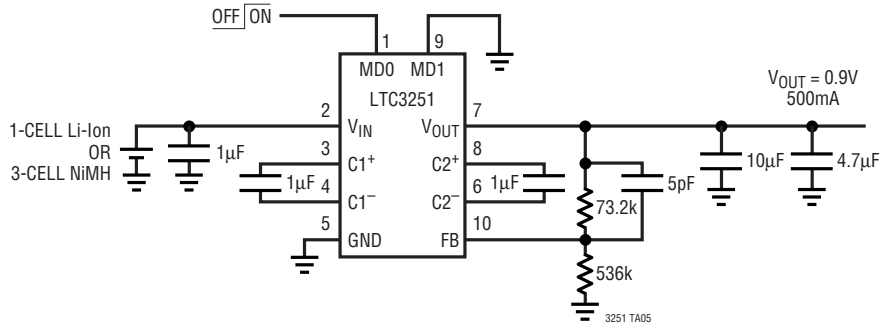

Figure 7. Programming the LTC3251

TYPICAL APPLICATION

0.9V Output Continuous/Burst Mode Operation with Shutdown



PACKAGE DESCRIPTION

MSE Package 10-Lead Plastic MSOP (Reference LTC DWG # 05-08-1663)

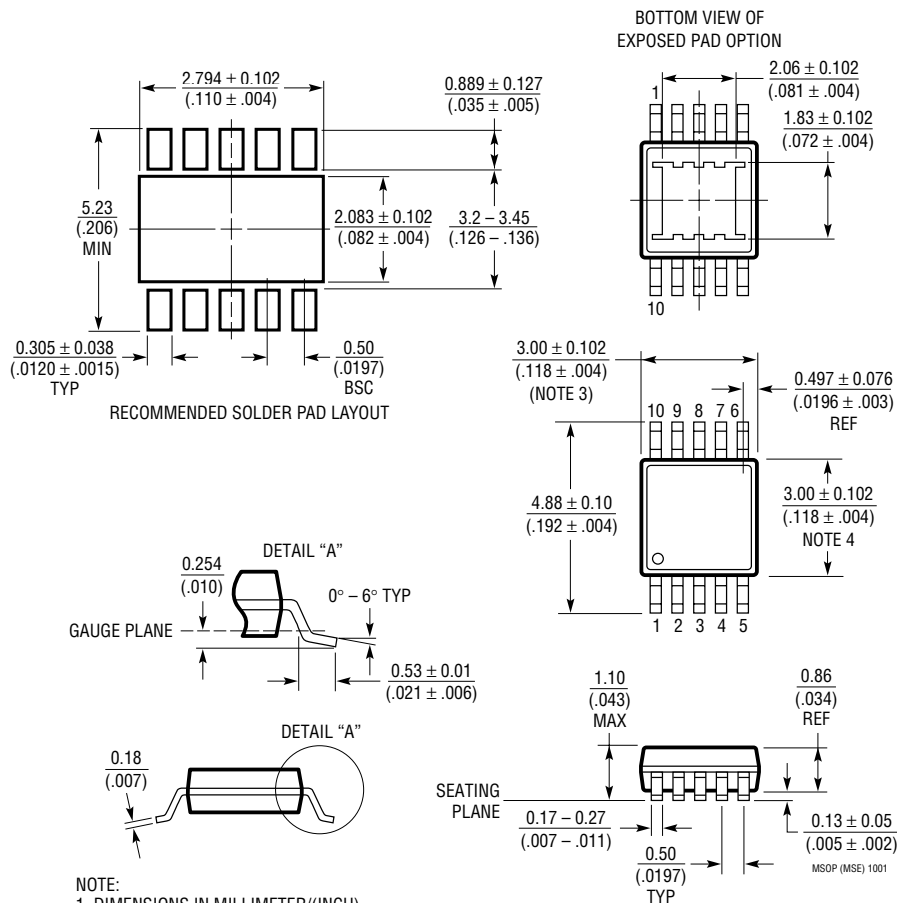

- NOTE:
1. DIMENSIONS IN MILLIMETER/(INCH)
 2. DRAWING NOT TO SCALE
 3. DIMENSION DOES NOT INCLUDE MOLD FLASH, PROTRUSIONS OR GATE BURRS.
MOLD FLASH, PROTRUSIONS OR GATE BURRS SHALL NOT EXCEED 0.152mm (.006") PER SIDE
 4. DIMENSION DOES NOT INCLUDE INTERLEAD FLASH OR PROTRUSIONS.
INTERLEAD FLASH OR PROTRUSIONS SHALL NOT EXCEED 0.152mm (.006") PER SIDE
 5. LEAD COPLANARITY (BOTTOM OF LEADS AFTER FORMING) SHALL BE 0.102mm (.004") MAX

LTC3251

TYPICAL APPLICATIONS

3.3V to 1.5V Conversion, Continuous Spread Spectrum Operation with Shutdown

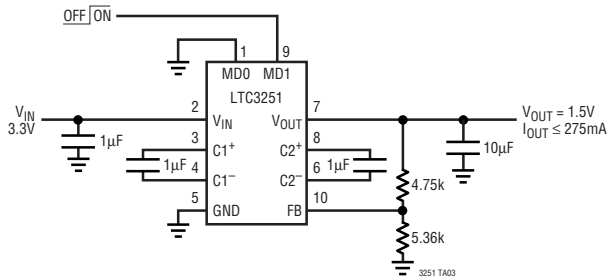

1.2V Output with μ Processor Control of Operating Modes

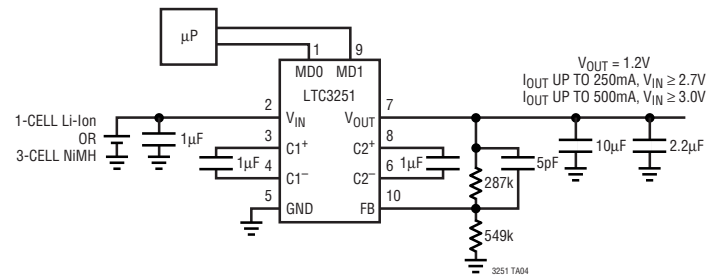

RELATED PARTS

PART NUMBER	DESCRIPTION	COMMENTS
LTC1514	50mA, 650kHz, Step-Up/Down Charge Pump with Low Battery Comparator	$V_{IN} = 2.7V$ to $10V$, $V_{OUT} = 3V$ or $5V$, Regulated Output, $I_Q = 60\mu A$, $I_{SHDN} = 10\mu A$, S8
LTC1515	50mA, 650kHz, Step-Up/Down Charge Pump with Power-On Reset	$V_{IN} = 2.7V$ to $10V$, $V_{OUT} = 3.3V$ or $5V$, Regulated Output, $I_Q = 60\mu A$, $I_{SHDN} = <1\mu A$, S8
LT1776	500mA (I_{OUT}), 200kHz, High Efficiency Step-Down DC/DC Converter	90% Efficiency, $V_{IN} = 7.4V$ to $40V$, V_{OUT} Min = $1.24V$, $I_Q = 3.2mA$, $I_{SHDN} = 30\mu A$, N8, S8
LTC1911-1.5	250mA, 1.5MHz, High Efficiency Step-Down Charge Pump	75% Efficiency, $V_{IN} = 2.7V$ to $5.5V$, $V_{OUT} = 1.5V$, Regulated Output, $I_Q = 180\mu A$, $I_{SHDN} = 10\mu A$, MS8
LTC1911-1.8	250mA, 1.5MHz, High Efficiency Step-Down Charge Pump	75% Efficiency, $V_{IN} = 2.7V$ to $5.5V$, $V_{OUT} = 1.8V$, Regulated Output, $I_Q = 180\mu A$, $I_{SHDN} = 10\mu A$, MS8
LTC3250-1.5	250mA, 1.5MHz, High Efficiency Step-Down Charge Pump	85% Efficiency, $V_{IN} = 3.1V$ to $5.5V$, $V_{OUT} = 1.5V$, Regulated Output, $I_Q = 35\mu A$, $I_{SHDN} = <1\mu A$, ThinSOT
LTC3404	600mA (I_{OUT}), 1.4MHz, Synchronous Step-Down DC/DC Converter	95% Efficiency, $V_{IN} = 2.7V$ to $6V$, V_{OUT} Min = $0.8V$, $I_Q = 10\mu A$, $I_{SHDN} = <1\mu A$, MS8
LTC3405/LTC3405A	300mA (I_{OUT}), 1.5MHz, Synchronous Step-Down DC/DC Converter	95% Efficiency, $V_{IN} = 2.7V$ to $6V$, V_{OUT} Min = $0.8V$, $I_Q = 20\mu A$, $I_{SHDN} = <1\mu A$, ThinSOT
LTC3406/LTC3406B	600mA (I_{OUT}), 1.5MHz, Synchronous Step-Down DC/DC Converter	95% Efficiency, $V_{IN} = 2.5V$ to $5.5V$, V_{OUT} Min = $0.6V$, $I_Q = 20\mu A$, $I_{SHDN} = <1\mu A$, ThinSOT
LTC3411	1.25A (I_{OUT}), 4MHz, Synchronous Step-Down DC/DC Converter	95% Efficiency, $V_{IN} = 2.5V$ to $5.5V$, V_{OUT} Min = $0.8V$, $I_Q = 60\mu A$, $I_{SHDN} = <1\mu A$, MS10
LTC3412	2.5A (I_{OUT}), 4MHz, Synchronous Step-Down DC/DC Converter	95% Efficiency, $V_{IN} = 2.5V$ to $5.5V$, V_{OUT} Min = $0.8V$, $I_Q = 60\mu A$, $I_{SHDN} = <1\mu A$, TSSOP-16E
LTC3440	600mA (I_{OUT}), 2MHz, Synchronous Buck-Boost DC/DC Converter	95% Efficiency, $V_{IN} = 2.5V$ to $5.5V$, V_{OUT} Min = $2.5V$, $I_Q = <25\mu A$, $I_{SHDN} = 1\mu A$, MS10