



Micropower Step-Down Switching Regulators in ThinSOT

October 2002

FEATURES

- Wide Input Voltage Range: 3.2V to 34V
- Micropower Operation: $I_Q = 12\mu A$
- 5V at 250mA from 6.5V to 34V Input (LT1934)
- 5V at 60mA from 6.5V to 34V Input (LT1934-1)
- 3.3V at 250mA from 4.5V to 34V Input (LT1934)
- 3.3V at 60mA from 4.5V to 34V Input (LT1934-1)
- Low Shutdown Current: $< 1\mu A$
- Low V_{CESAT} Switch: 200mV at 300mA
- Low Profile (1mm) ThinSOT™ Package

APPLICATIONS

- Wall Transformer Regulation
- Automotive Battery Regulation
- Standby Power for Portable Products
- Distributed Supply Regulation
- Industrial Control Supplies

DESCRIPTION

The LT[®]1934 is a micropower step-down DC/DC converter with internal 400mA power switch, packaged in a low profile (1mm) ThinSOT. With its wide input range of 3.2V to 34V, the LT1934 can regulate a wide variety of power sources, from 4-cell alkaline batteries and 5V logic rails to unregulated wall transformers and lead-acid batteries. Quiescent current is just 12 μA and a zero current shutdown mode disconnects the load from the input source, simplifying power management in battery-powered systems. Burst Mode[®] operation and the low drop internal power switch result in high efficiency over a broad range of load current.

The LT1934 provides up to 300mA of output current. The LT1934-1 has a lower current limit, allowing optimum choice of external components when the required output current is less than 60mA. Fast current limiting protects the LT1934 and external components against shorted outputs, even at 34V input.

LT, LTC and LT are registered trademarks of Linear Technology Corporation.
Burst Mode is a registered trademark of Linear Technology Corporation.
ThinSOT is a trademark of Linear Technology Corporation.

TYPICAL APPLICATION

3.3V Step-Down Converter

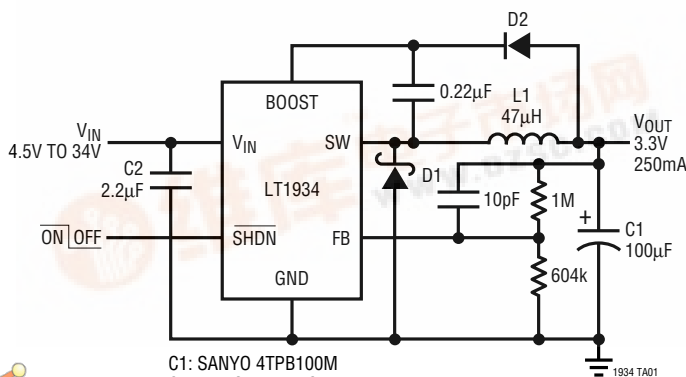

- C1: SANYO 4TPB100M
- C2: TAIYO YUDEN GMK325BJ225MN
- D1: ZETEX ZHCS400
- D2: CENTRAL CMDSH-3
- L1: SUMIDA CDRH4D28-470

Efficiency

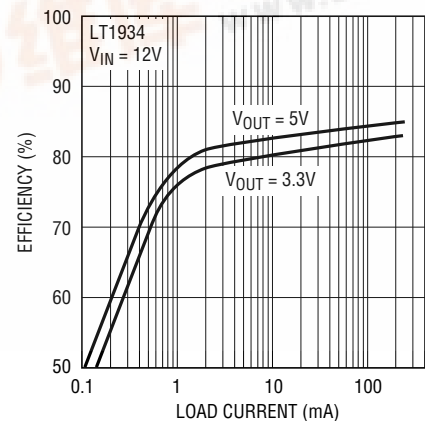

1934 TA02

LT1934/LT1934-1

ABSOLUTE MAXIMUM RATINGS

(Note 1)

Input Voltage (V_{IN})	34V
BOOST Pin Voltage	40V
BOOST Pin Above SW Pin	20V
SHDN Pin	34V
FB Voltage	6V
SW Voltage	V_{IN}
Operating Temperature Range (Note 2) ..	-40°C to 85°C
Maximum Junction Temperature	125°C
Storage Temperature Range	-65°C to 150°C
Lead Temperature (Soldering, 10 sec).....	300°C

PACKAGE/ORDER INFORMATION

	ORDER PART NUMBER
	LT1934ES6 LT1934ES6-1
	S6 PART MARKING
	LTXP LTF8

Consult LTC Marketing for parts specified with wider operating temperature ranges.

ELECTRICAL CHARACTERISTICS

The ● denotes specifications which apply over the full operating temperature range, otherwise specifications are at $T_A = 25^\circ\text{C}$. $V_{IN} = 10\text{V}$, $V_{BOOST} = 15\text{V}$, unless otherwise noted.

PARAMETER	CONDITIONS	MIN	TYP	MAX	UNITS
Undervoltage Lockout			3	3.2	V
Quiescent Current	$V_{FB} = 1.3\text{V}$ $V_{SHDN} = 0\text{V}$		12 0.01	22 2	μA μA
FB Comparator Trip Voltage	V_{FB} Falling	● 1.22	1.25	1.27	V
FB Comparator Hysteresis			10		mV
FB Pin Bias Current (Note 3)	$V_{FB} = 1.25\text{V}$	●	2	15	nA
FB Voltage Line Regulation	$4\text{V} < V_{IN} < 34\text{V}$		0.007		%/V
Switch Off Time	$V_{FB} > 1\text{V}$ $V_{FB} = 0\text{V}$		1.4 12	1.8 2.3	μs μs
Maximum Duty Cycle	$V_{FB} = 1\text{V}$	● 85	88		%
Switch V_{CESAT}	$I_{SW} = 300\text{mA}$ (LT1934) $I_{SW} = 75\text{mA}$ (LT1934-1)		200 65	300 120	mV mV
Switch Current Limit	LT1934 LT1934-1	350 90	400 120	490 160	mA mA
BOOST Pin Current	$I_{SW} = 300\text{mA}$ (LT1934) $I_{SW} = 75\text{mA}$ (LT1934-1)		8.5 6.0	12 10	mA mA
Minimum Boost Voltage (Note 4)	$I_{SW} = 300\text{mA}$ (LT1934) $I_{SW} = 75\text{mA}$ (LT1934-1)		1.8 1.7	2.5 2.5	V V
Switch Leakage Current				2	μA
SHDN Pin Current	$V_{SHDN} = 2.3\text{V}$ $V_{SHDN} = 34\text{V}$		0.5 1.5	5	μA μA
SHDN Input Voltage High		2.3			V
SHDN Input Voltage Low				0.25	V

Note 1: Absolute Maximum Ratings are those values beyond which the life of the device may be impaired.

Note 2: The LT1934E and LT1934E-1 are guaranteed to meet performance specifications from 0°C to 70°C. Specifications over the -40°C to 85°C operating temperature range are assured by design, characterization and correlation with statistical process controls.

Note 3: Bias current flows out of the FB pin.

Note 4: This is the minimum voltage across the boost capacitor needed to guarantee full saturation of the internal power switch.

TYPICAL PERFORMANCE CHARACTERISTICS

LT1934 Efficiency, $V_{OUT} = 5V$

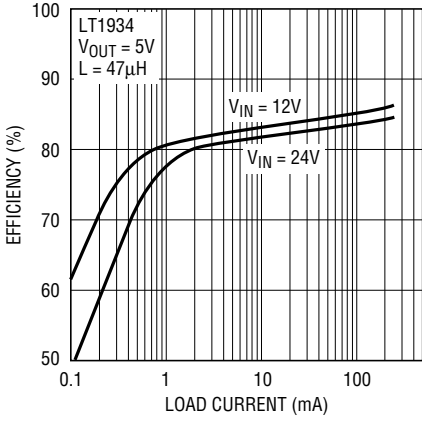

LT1934 Efficiency, $V_{OUT} = 3.3V$

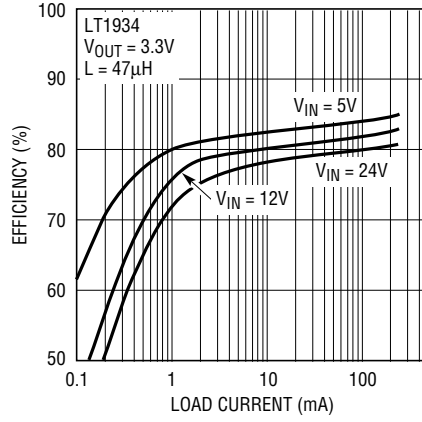

LT1934-1 Efficiency, $V_{OUT} = 5V$

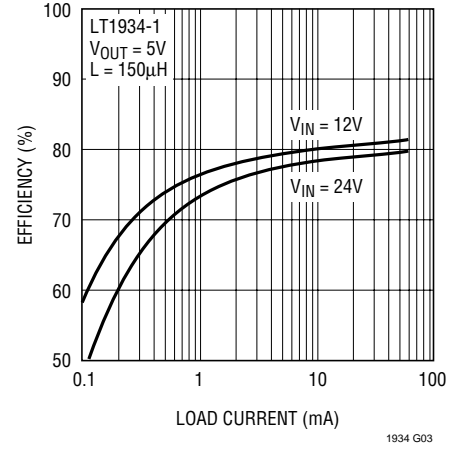

LT1934-1 Efficiency, $V_{OUT} = 3.3V$

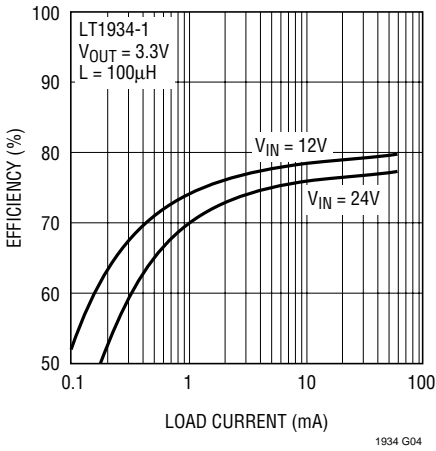

Current Limit vs Temperature

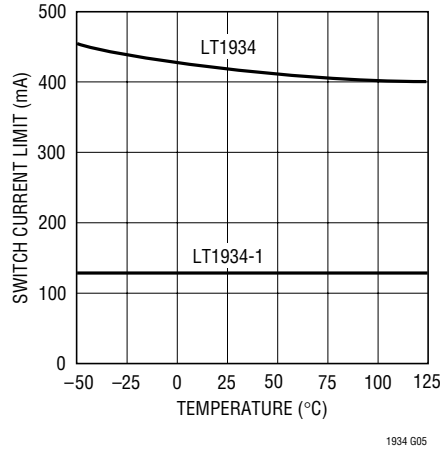

Off Time vs Temperature

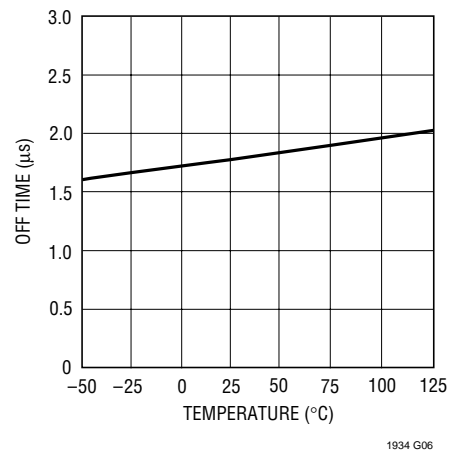

Frequency Foldback

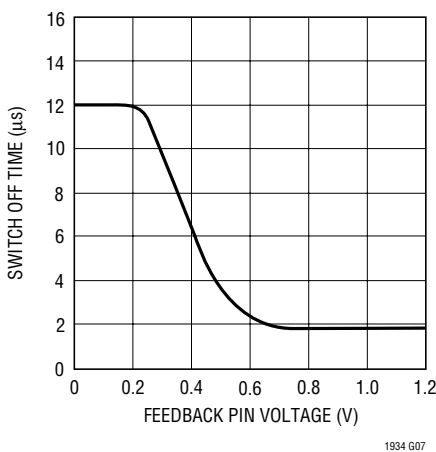

V_{FB} vs Temperature

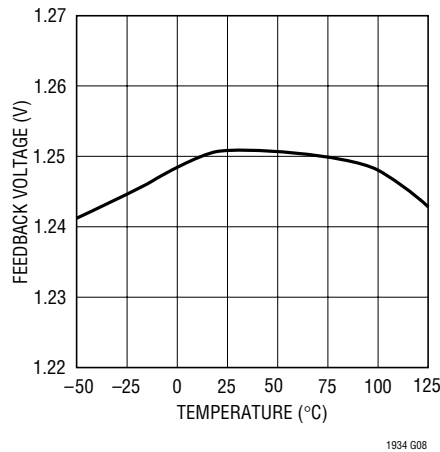

SHDN Bias Current vs SHDN Voltage

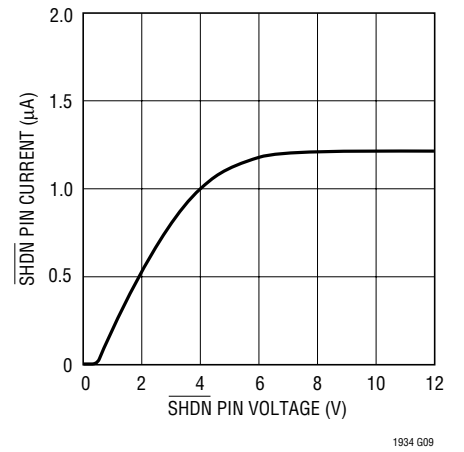

TYPICAL PERFORMANCE CHARACTERISTICS

Quiescent Current vs Temperature

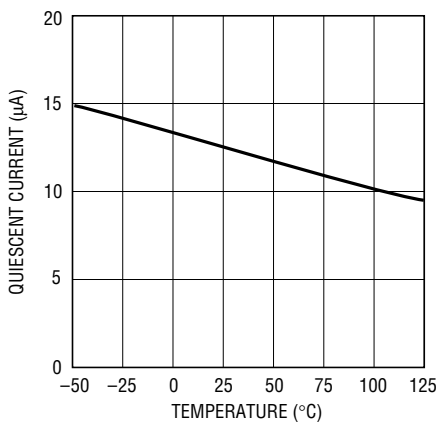

1934 G10

Undervoltage Lockout vs Temperature

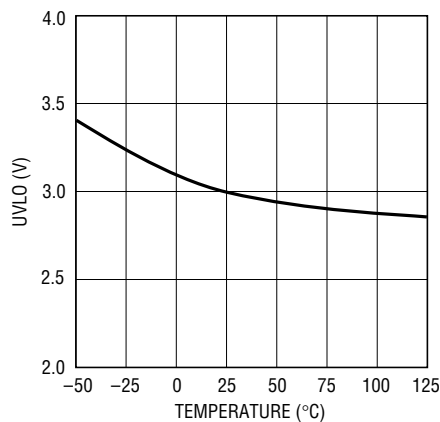

1934 G11

**Minimum Input Voltage
V_{OUT} = 3.3V**

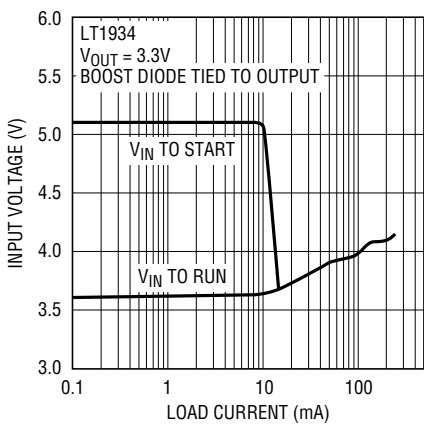

1934 G12

**Minimum Input Voltage
V_{OUT} = 5V**

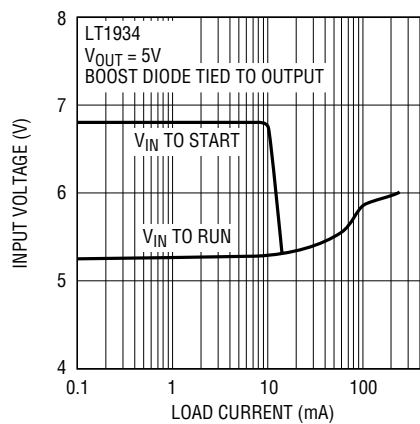

1934 G13

PIN FUNCTIONS

BOOST (Pin 1): The BOOST pin is used to provide a drive voltage, higher than the input voltage, to the internal bipolar NPN power switch.

GND (Pin 2): Tie the GND pin to a local ground plane below the LT1934 and the circuit components. Return the feedback divider to this pin.

FB (Pin 3): The LT1934 regulates its feedback pin to 1.25V. Connect the feedback resistor divider tap to this pin. Set the output voltage according to $V_{OUT} = 1.25V (1 + R1/R2)$ or $R1 = R2 (V_{OUT}/1.25 - 1)$.

SHDN (Pin 4): The $\overline{\text{SHDN}}$ pin is used to put the LT1934 in shutdown mode. Tie to ground to shut down the LT1934. Apply 2.3V or more for normal operation. If the shutdown feature is not used, tie this pin to the V_{IN} pin.

V_{IN} (Pin 5): The V_{IN} pin supplies current to the LT1934's internal regulator and to the internal power switch. This pin must be locally bypassed.

SW (Pin 6): The SW pin is the output of the internal power switch. Connect this pin to the inductor, catch diode and boost capacitor.

BLOCK DIAGRAM

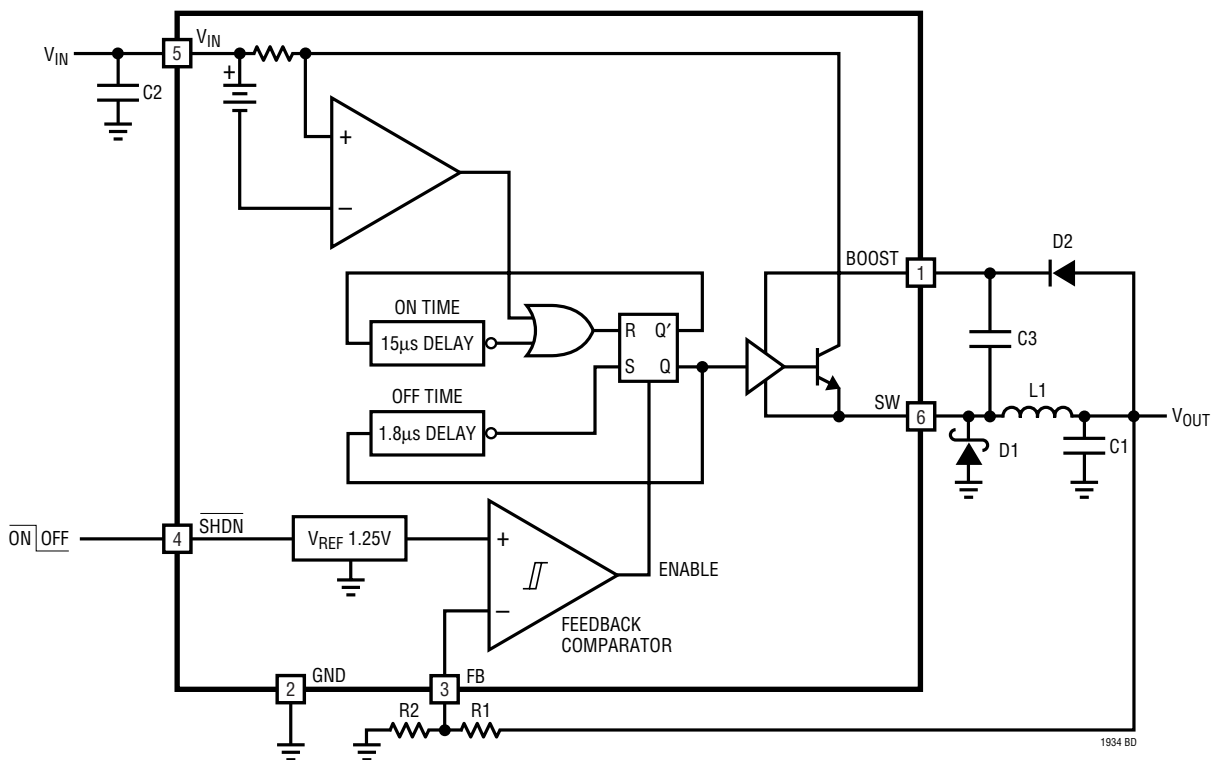

LT1934/LT1934-1

OPERATION (Refer to Block Diagram)

The LT1934 uses Burst Mode control, combining both low quiescent current operation and high switching frequency, which result in high efficiency across a wide range of load currents and a small total circuit size.

A comparator monitors the voltage at the FB pin of the LT1934. If this voltage is higher than the internal 1.25V reference, the comparator disables the oscillator and power switch. In this state, only the comparator, reference and undervoltage lockout circuits are active, and the current into the V_{IN} pin is just 12 μ A. As the load current discharges the output capacitor, the voltage at the FB pin falls below 1.25V and the comparator enables the oscillator. The LT1934 begins to switch, delivering current to the output capacitor. The output voltage rises, and when it overcomes the feedback comparator's hysteresis, the oscillator is disabled and the LT1934 returns to its micropower state.

The oscillator consists of two one-shots and a flip-flop. A rising edge from the off-time one-shot sets the flip-flop, which turns on the internal NPN power switch. The switch remains on until either the on-time one-shot trips or the current limit is reached. A sense resistor and amplifier monitor the current through the switch and resets

the flip-flop when this current reaches 400mA (120mA for the LT1934-1). After the 1.8 μ s delay of the off-time one-shot, the cycle repeats. Generally, the LT1934 will reach current limit on every cycle—the off time is fixed and the on time is regulated so that the LT1934 operates at the correct duty cycle. The 1.8 μ s off time is lengthened when the FB pin voltage falls below 0.8V; this foldback behavior helps control the output current during start-up and overload. Figure 1 shows several waveforms of an LT1934 producing 3.3V from a 10V input. When the switch is on, the SW pin voltage is at 10V. When the switch is off, the inductor current pulls the SW pin down until it is clamped near ground by the external catch diode.

The switch driver operates from either the input or from the BOOST pin. An external capacitor and diode are used to generate a voltage at the BOOST pin that is higher than the input supply. This allows the driver to fully saturate the bipolar switch for efficient operation.

If the $\overline{\text{SHDN}}$ pin is grounded, all internal circuits are turned off and V_{IN} current reduces to the device leakage current, typically a few nA.

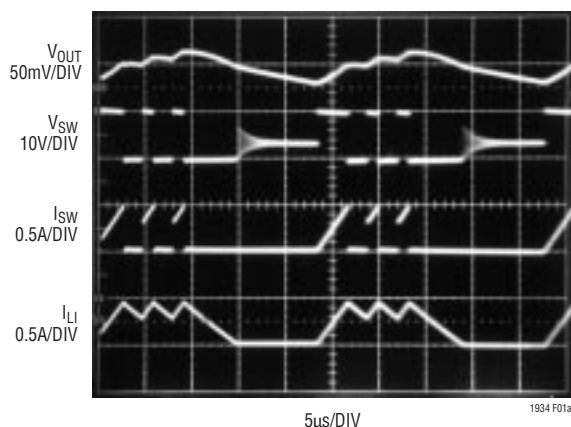

Figure 1. Operating Waveforms of the LT1934 Converting 10V to 3.3V at 180mA (Front Page Schematic)

APPLICATIONS INFORMATION

Which One to Use: LT1934 or LT1934-1?

The only difference between the LT1934 and LT1934-1 is the peak current through the internal switch and the inductor. If your maximum load current is less than 60mA, use the LT1934-1. If your maximum load is higher, use the LT1934; it can supply up to ~300mA.

While the LT1934-1 can't deliver as much output current, it has other advantages. The lower peak switch current allows the use of smaller components (input capacitor, inductor and output capacitor). The ripple current at the input of the LT1934-1 circuit will be smaller and may be an important consideration if the input supply is current limited or has high impedance. The LT1934-1's current draw during faults (output overload or short) and start-up is lower.

The maximum load current that the LT1934 or LT1934-1 can deliver depends on the value of the inductor used. Table 1 lists inductor value, minimum output capacitor and maximum load for 3.3V and 5V circuits. Increasing the value of the capacitor will lower the output voltage ripple. Component selection is covered in more detail in the following sections.

Minimum Input Voltage

The minimum input voltage required to generate a particular output voltage is determined by either the LT1934's undervoltage lockout of ~3V or by its maximum duty

cycle. The duty cycle is the fraction of time that the internal switch is on and is determined by the input and output voltages:

$$DC = (V_{OUT} + V_D)/(V_{IN} - V_{SW} + V_D)$$

where V_D is the forward voltage drop of the catch diode (~0.4V) and V_{SW} is the voltage drop of the internal switch (~0.3V at maximum load for the LT1934, ~0.1V for the LT1934-1). This leads to a minimum input voltage of:

$$V_{IN(MIN)} = (V_{OUT} + V_D)/DC_{MAX} - V_D + V_{SW}$$

with $DC_{MAX} = 0.85$.

Inductor Selection

A good first choice for the inductor value is:

$$L = 2.5 \cdot (V_{OUT} + V_D) \cdot 1.8\mu s / I_{LIM}$$

where I_{LIM} is the switch current limit (400mA for the LT1934 and 120mA for the LT1934-1). This choice provides a worst-case maximum load current of 250mA (60mA for the LT1934-1). The inductor's RMS current rating must be greater than the load current and its saturation current should be greater than I_{LIM} . To keep efficiency high, the series resistance (DCR) should be less than 0.3 Ω (1 Ω for the LT1934-1). Table 2 lists several vendors and types that are suitable.

This simple rule may not provide the optimum value for your application. If the load current is less, then you can relax the value of the inductor and operate with higher ripple current. This allows you to use a physically smaller inductor, or one with a lower DCR resulting in higher efficiency. The following provides more details to guide inductor selection. First, the value must be chosen so that the LT1934 can supply the maximum load current drawn from the output. Second, the inductor must be rated appropriately so that the LT1934 will function reliably and the inductor itself will not be overly stressed.

Detailed Inductor Selection and Maximum Load Current

The square wave that the LT1934 produces at its switch pin results in a triangle wave of current in the inductor. The LT1934 limits the peak inductor current to I_{LIM} . Because

Table 1

PART	V _{OUT}	L	MINIMUM C _{OUT}	MAXIMUM LOAD
LT1934	3.3V	100 μ H	100 μ F	300mA
		47 μ H	47 μ F	250mA
		33 μ H	33 μ F	200mA
	5V	150 μ H	47 μ F	300mA
		68 μ H	33 μ F	250mA
		47 μ H	22 μ F	200mA
LT1934-1	3.3V	150 μ H	15 μ F	60mA
		100 μ H	10 μ F	45mA
		68 μ H	10 μ F	20mA
	5V	220 μ H	10 μ F	60mA
		150 μ H	4.7 μ F	45mA
		100 μ H	4.7 μ F	20mA

APPLICATIONS INFORMATION

Table 2. Inductor Vendors

Vendor	Phone	URL	Part Series	Comments
Murata	(404) 426-1300	www.murata.com	LQH3C	Small, Low Cost, 2mm Height
Sumida	(847) 956-0666	www.sumida.com	CR43 CDRH4D28 CDRH5D28	
Coilcraft	(847) 639-6400	www.coilcraft.com	DO1607C DO1608C DT1608C	
Würth Electronics	(866) 362-6673	www.we-online.com	WE-PD1, 2, 3, 4	

the average inductor current equals the load current, the maximum load current is:

$$I_{OUT(MAX)} = I_{PK} - \Delta I_L / 2$$

where I_{PK} is the peak inductor current and ΔI_L is the peak-to-peak ripple current in the inductor. The ripple current is determined by the off time, $t_{OFF} = 1.8\mu s$, and the inductor value:

$$\Delta I_L = (V_{OUT} + V_D) \cdot t_{OFF} / L$$

I_{PK} is nominally equal to I_{LIM} . However, there is a slight delay in the control circuitry that results in a higher peak current and a more accurate value is:

$$I_{PK} = I_{LIM} + 150ns \cdot (V_{IN} - V_{OUT}) / L$$

These expressions are combined to give the maximum load current that the LT1934 will deliver:

$$I_{OUT(MAX)} = 350mA + 150ns \cdot (V_{IN} - V_{OUT}) / L - 1.8\mu s \cdot (V_{OUT} + V_D) / 2L \text{ (LT1934)}$$

$$I_{OUT(MAX)} = 90mA + 150ns \cdot (V_{IN} - V_{OUT}) / L - 1.8\mu s \cdot (V_{OUT} + V_D) / 2L \text{ (LT1934-1)}$$

The minimum current limit is used here to be conservative. The third term is generally larger than the second term, so that increasing the inductor value results in a higher output current. This equation can be used to evaluate a chosen inductor or it can be used to choose L for a given maximum load current. The simple, single equation rule given above for choosing L was found by setting $\Delta I_L = I_{LIM} / 2.5$. This results in $I_{OUT(MAX)} \sim 0.8I_{LIM}$ (ignoring the delay term). Note that this analysis assumes that the inductor current is continuous, which is true if the ripple current is less than the peak current or $\Delta I_L < I_{PK}$.

The inductor must carry the peak current without saturating excessively. When an inductor carries too much current, its core material can no longer generate additional magnetic flux (it saturates) and the inductance drops, sometimes very rapidly with increasing current. This condition allows the inductor current to increase at a very high rate, leading to high ripple current and decreased overload protection.

Inductor vendors provide current ratings for power inductors. These are based on either the saturation current or on the RMS current that the inductor can carry without dissipating too much power. In some cases it is not clear which of these two determine the current rating. Some data sheets are more thorough and show two current ratings, one for saturation and one for dissipation. For LT1934 applications, the RMS current rating should be higher than the load current, while the saturation current should be higher than the peak inductor current calculated above.

Input Capacitor

Step-down regulators draw current from the input supply in pulses with very fast rise and fall times. The input capacitor is required to reduce the resulting voltage ripple at the LT1934 and to force this switching current into a tight local loop, minimizing EMI. The input capacitor must have low impedance at the switching frequency to do this effectively. A $2.2\mu F$ ceramic capacitor ($1\mu F$ for the LT1934-1) satisfies these requirements.

If the input source impedance is high, a larger value capacitor may be required to keep input ripple low. In this case, an electrolytic of $10\mu F$ or more in parallel with a $1\mu F$ ceramic is a good combination. Be aware that the input

APPLICATIONS INFORMATION

capacitor is subject to large surge currents if the LT1934 circuit is connected to a low impedance supply, and that some electrolytic capacitors (in particular tantalum) must be specified for such use.

Output Capacitor and Output Ripple

The output capacitor filters the inductor’s ripple current and stores energy to satisfy the load current when the LT1934 is quiescent. In order to keep output voltage ripple low, the impedance of the capacitor must be low at the LT1934’s switching frequency. The capacitor’s equivalent series resistance (ESR) determines this impedance. Choose one with low ESR intended for use in switching regulators. The contribution to ripple voltage due to the ESR is approximately $I_{LIM} \cdot ESR$. ESR should be less than $\sim 150m\Omega$ for the LT1934 and less than $\sim 500m\Omega$ for the LT1934-1.

The value of the output capacitor must be large enough to accept the energy stored in the inductor without a large change in output voltage. Setting this voltage step equal to 1% of the output voltage, the output capacitor must be:

$$C_{OUT} > 50 \cdot L \cdot (I_{LIM}/V_{OUT})^2$$

For example, an LT1934 producing 3.3V with $L = 47\mu H$ requires $33\mu F$. This value can be relaxed if small circuit size is more important than low output ripple.

Sanyo’s POSCAP series in B-case and C-case sizes provides very good performance in a small package for the LT1934. Similar performance in traditional tantalum capacitors requires a larger package (C- or D-case). The

LT1934-1, with its lower switch current, can use a B-case tantalum capacitor.

With a high quality capacitor filtering the ripple current from the inductor, the output voltage ripple is determined by the hysteresis and delay in the LT1934’s feedback comparator. This ripple can be reduced further by adding a small (typically 10pF) phase lead capacitor between the output and the feedback pin.

Ceramic Capacitors

Ceramic capacitors are small, robust and have very low ESR. However, ceramic capacitors can cause problems when used with the LT1934.

Not all ceramic capacitors are suitable. X5R and X7R types are stable over temperature and applied voltage and give dependable service. Other types (Y5V and Z5U) have very large temperature and voltage coefficients of capacitance. In the application circuit they may have only a small fraction of their nominal capacitance and voltage ripple may be much larger than expected.

Ceramic capacitors are piezoelectric. The LT1934’s switching frequency depends on the load current, and at light loads the LT1934 can excite the ceramic capacitor at audio frequencies, generating audible noise. If this is unacceptable, use a high performance electrolytic capacitor at the output. The input capacitor can be a parallel combination of a $2.2\mu F$ ceramic capacitor and a low cost electrolytic capacitor. The level of noise produced by the LT1934-1

Table 3. Capacitor Vendors

Vendor	Phone	URL	Part Series	Comments
Panasonic	(714) 373-7366	www.panasonic.com	Ceramic, Polymer, Tantalum	EEF Series
Kemet	(864) 963-6300	www.kemet.com	Ceramic, Tantalum	T494, T495
Sanyo	(408) 749-9714	www.sanyovideo.com	Ceramic, Polymer, Tantalum	POSCAP
Murata	(404) 436-1300	www.murata.com	Ceramic	
AVX		www.avxcorp.com	Ceramic, Tantalum	TPS Series
Taiyo Yuden	(864) 963-6300	www.taiyo-yuden.com	Ceramic	

APPLICATIONS INFORMATION

when used with ceramic capacitors will be lower and may be acceptable.

A final precaution regarding ceramic capacitors concerns the maximum input voltage rating of the LT1934. Because ceramic capacitors have low series resistance, they can combine with trace or cable inductance to produce a high quality (under damped) tank circuit. If the input of the LT1934 is bypassed with a ceramic capacitor and the circuit is connected to a low impedance voltage source through a cable, then the input voltage can ring to twice its nominal value and exceed the LT1934's rating, damaging the part. To avoid this, include a high ESR electrolytic capacitor in parallel with the ceramic capacitor. This will damp the tank circuit and prevent the voltage overshoot. See Application Note 88 for more details.

Catch Diode

A 0.5A Schottky diode is recommended for the catch diode, D1. The diode must have a reverse voltage rating equal to or greater than the maximum input voltage. The ON Semiconductor MBR0540 is a good choice; it is rated for 0.5A forward current and a maximum reverse voltage of 40V. The Zetex ZHCS400 is a similar part in a smaller package.

Schottky diodes with lower reverse voltage ratings usually have a lower forward drop and may result in higher efficiency with moderate to high load currents. However, these diodes also have higher leakage currents. This leakage current mimics a load current at the output and can raise the quiescent current of the LT1934 circuit, especially at elevated temperatures.

BOOST Pin Considerations

Capacitor C3 and diode D2 are used to generate a boost voltage that is higher than the input voltage. In most cases a 0.1μF capacitor and fast switching diode (such as the 1N4148 or 1N914) will work well. Figure 2 shows two ways to arrange the boost circuit. The BOOST pin must be more than 2.5V above the SW pin for best efficiency. For outputs of 3.3V and above, the standard circuit (Figure 2a) is best. For outputs between 2.8V and 3V, use a 0.22μF

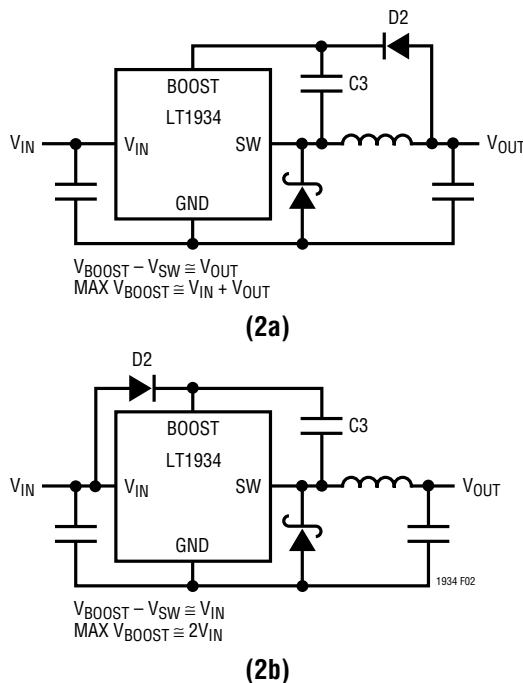

Figure 2. Two Circuits for Generating the Boost Voltage

capacitor and a small Schottky diode (such as the BAT-54). For lower output voltages the boost diode can be tied to the input (Figure 2b). The circuit in Figure 2a is more efficient because the BOOST pin current comes from a lower voltage source. You must also be sure that the maximum voltage rating of the BOOST pin is not exceeded.

The minimum operating voltage of an LT1934 application is limited by the undervoltage lockout (~3V) and by the maximum duty cycle as outlined above. For proper start-up, the minimum input voltage is also limited by the boost circuit. If the input voltage is ramped slowly, or the LT1934 is turned on with its \overline{SHDN} pin when the output is already in regulation, then the boost capacitor may not be fully charged. Because the boost capacitor is charged with the energy stored in the inductor, the circuit will rely on some minimum load current to get the boost circuit running properly. This minimum load will depend on input and output voltages, and on the arrangement of the boost circuit. The minimum load generally goes to zero once the circuit has started. Figure 3 shows a plot of minimum load

APPLICATIONS INFORMATION

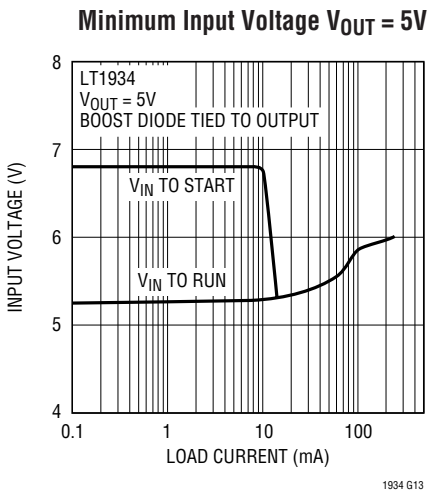
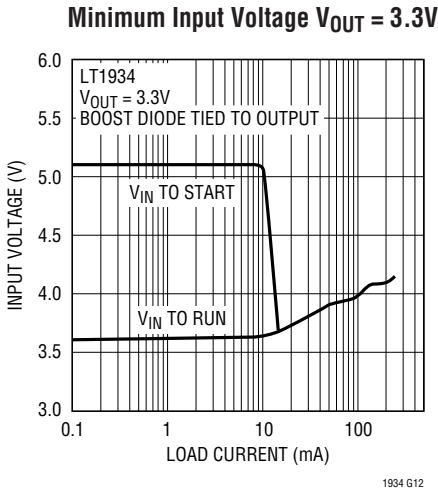

Figure 3. The Minimum Input Voltage Depends on Output Voltage, Load Current and Boost Circuit

to start and to run as a function of input voltage. In many cases the discharged output capacitor will present a load to the switcher which will allow it to start. The plots show the worst-case situation where V_{IN} is ramping very slowly. Use a Schottky diode (such as the BAT-54) for the lowest start-up voltage.

Shorted Input Protection

If the inductor is chosen so that it won't saturate excessively, an LT1934 buck regulator will tolerate a shorted output. There is another situation to consider in systems where the output will be held high when the input to the LT1934 is absent. This may occur in battery charging

applications or in battery backup systems where a battery or some other supply is diode OR-ed with the LT1934's output. If the V_{IN} pin is allowed to float and the \overline{SHDN} pin is held high (either by a logic signal or because it is tied to V_{IN}), then the LT1934's internal circuitry will pull its quiescent current through its SW pin. This is fine if your system can tolerate a few mA in this state. If you ground the \overline{SHDN} pin, the SW pin current will drop to essentially zero. However, if the V_{IN} pin is grounded while the output is held high, then parasitic diodes inside the LT1934 can pull large currents from the output through the SW pin and the V_{IN} pin. Figure 4 shows a circuit that will run only when the input voltage is present and that protects against a shorted or reversed input.

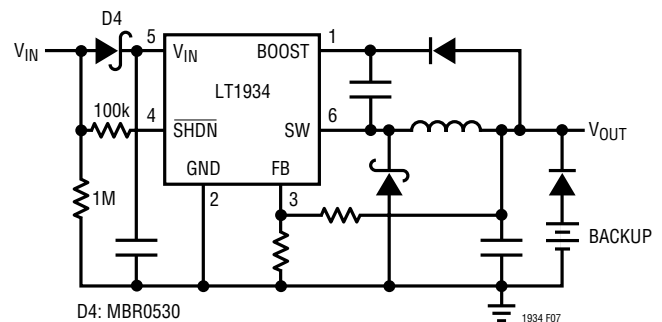

Figure 4. Diode D4 Prevents a Shorted Input from Discharging a Backup Battery Tied to the Output; It Also Protects the Circuit from a Reversed Input. The LT1934 Runs Only When the Input is Present

PCB Layout

For proper operation and minimum EMI, care must be taken during printed circuit board layout. Figure 5 shows the high current paths in the buck regulator circuit. Note that large, switched currents flow in the power switch, the catch diode (D1) and the input capacitor (C2). The loop formed by these components should be as small as possible. Furthermore, the system ground should be tied to the regulator ground in only one place; this prevents the switched current from injecting noise into the system ground. These components, along with the inductor and output capacitor, should be placed on the same side of the circuit board, and their connections should be made on that layer. Place a local, unbroken ground plane below these components, and tie this ground plane to system

APPLICATIONS INFORMATION

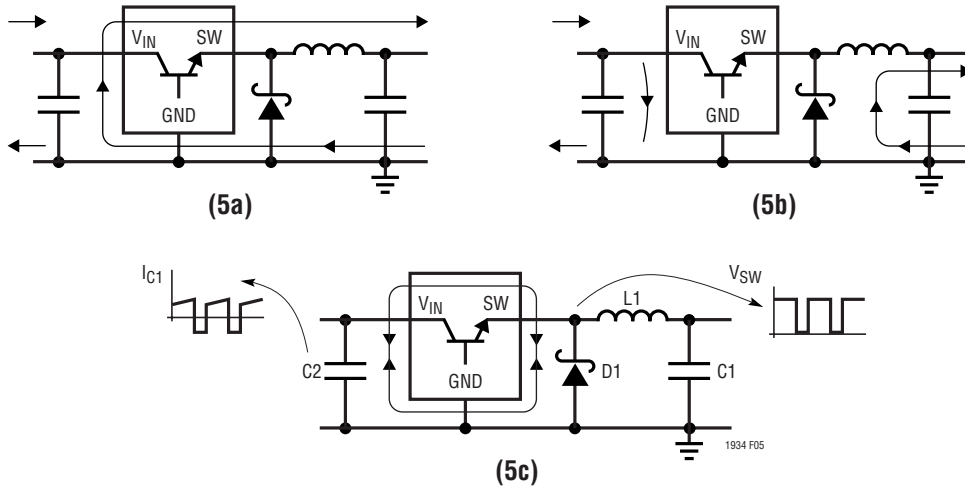

Figure 5. Subtracting the Current When the Switch is On (a) from the Current When the Switch is Off (b) Reveals the Path of the High Frequency Switching Current (c). Keep This Loop Small. The Voltage on the SW and BOOST Nodes Will Also be Switched; Keep These Nodes as Small as Possible. Finally, Make Sure the Circuit is Shielded with a Local Ground Plane

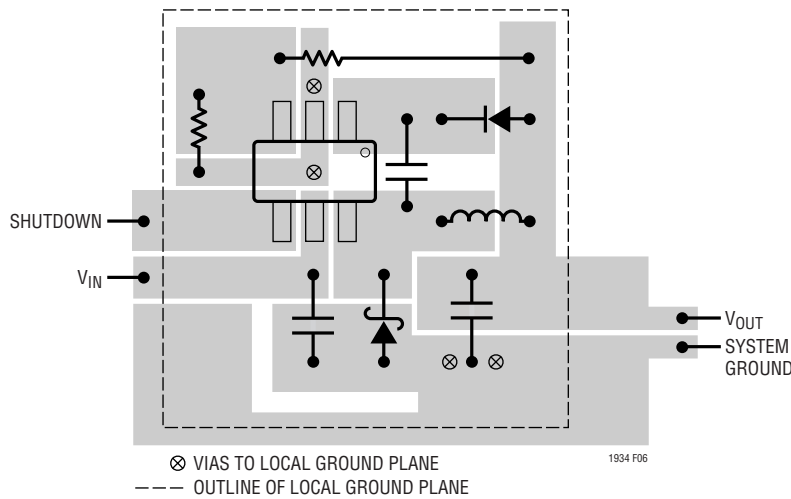

Figure 6. A Good PCB Layout Ensures Proper, Low EMI Operation

ground at one location, ideally at the ground terminal of the output capacitor C1. Additionally, the SW and BOOST nodes should be kept as small as possible. Finally, keep the FB node as small as possible so that the ground pin and ground traces will shield it from the SW and BOOST nodes.

Figure 6 shows component placement with trace, ground plane and via locations. Include two vias near the GND pin of the LT1934 to help remove heat from the LT1934 to the ground plane.

TYPICAL APPLICATIONS

3.3V Step-Down Converter

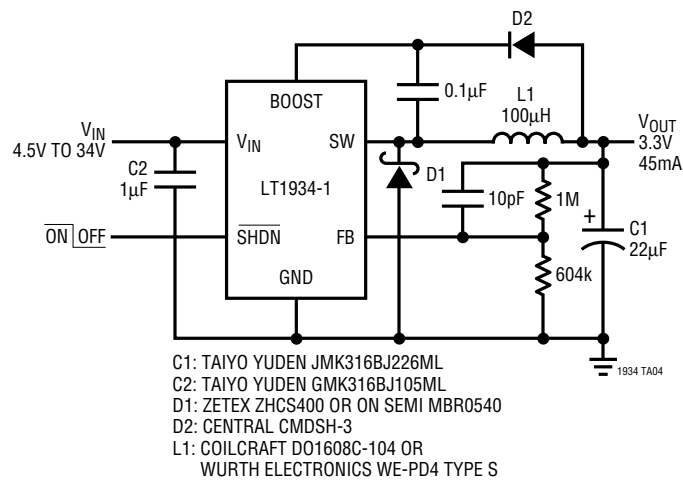

5V Step-Down Converter

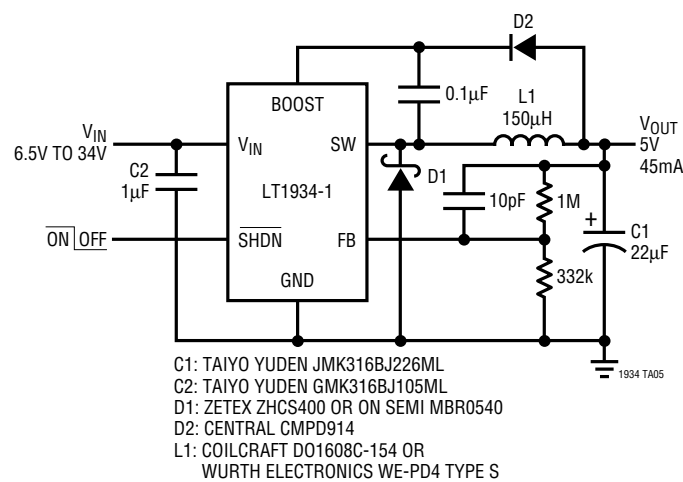

TYPICAL APPLICATIONS

1.8V Step-Down Converter

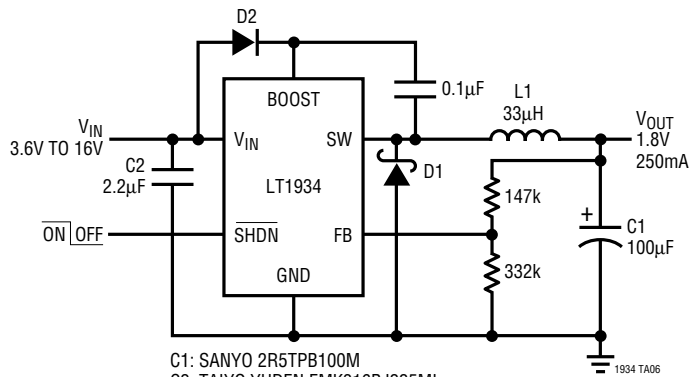

- C1: SANYO 2R5TPB100M
- C2: TAIYO YUDEN EMK316BJ225ML
- D1: ZETEX ZHCS400 OR ON SEMI MBR0540
- D2: CENTRAL CMPD914
- L1: SUMIDA CR43-330

PACKAGE DESCRIPTION

S6 Package
6-Lead Plastic TSOT-23
 (Reference LTC DWG # 05-08-1636)

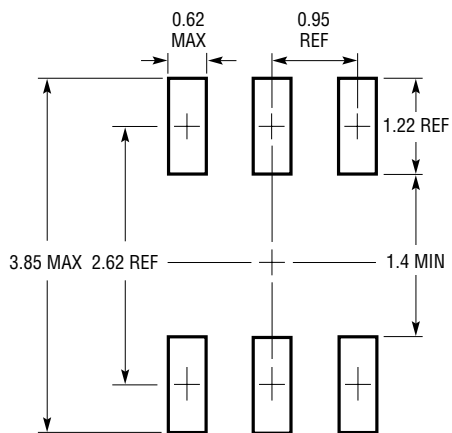

RECOMMENDED SOLDER PAD LAYOUT
 PER IPC CALCULATOR

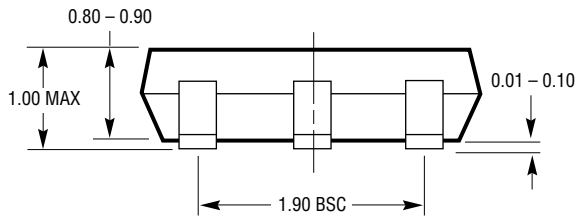
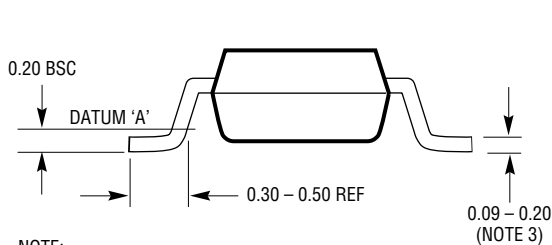
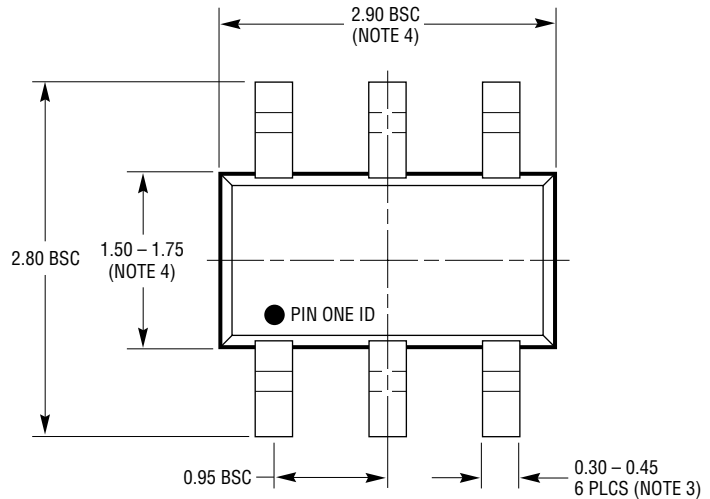

S6 TSOT-23 0302

- NOTE:
1. DIMENSIONS ARE IN MILLIMETERS
 2. DRAWING NOT TO SCALE
 3. DIMENSIONS ARE INCLUSIVE OF PLATING
 4. DIMENSIONS ARE EXCLUSIVE OF MOLD FLASH AND METAL BURR
 5. MOLD FLASH SHALL NOT EXCEED 0.254mm
 6. JEDEC PACKAGE REFERENCE IS MO-193

LT1934/LT1934-1

TYPICAL APPLICATION

5V Step-Down Converter

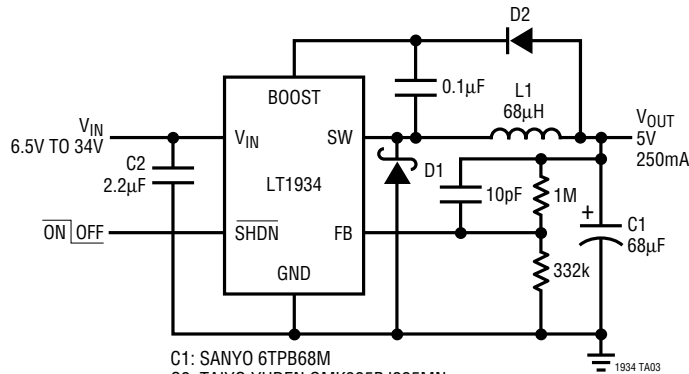

C1: SANYO 6TPB68M
 C2: TAIYO YUDEN GMK325BJ225MN
 D1: ZETEX ZHCS400 OR ON SEMI MBR0540
 D2: CENTRAL CMPD914
 L1: SUMIDA CDRH5D28-680

RELATED PARTS

PART NUMBER	DESCRIPTION	COMMENTS
LT1616	25V, 500mA (I_{OUT}), 1.4MHz, High Efficiency Step-Down DC/DC Converter	$V_{IN} = 3.6V$ to 25V, $V_{OUT} = 1.25V$, $I_Q = 1.9mA$, $I_{SD} = <1\mu A$, ThinSOT Package
LT1676	60V, 440mA (I_{OUT}), 100kHz, High Efficiency Step-Down DC/DC Converter	$V_{IN} = 7.4V$ to 60V, $V_{OUT} = 1.24V$, $I_Q = 3.2mA$, $I_{SD} = 2.5\mu A$, S8 Package
LT1765	25V, 2.75A (I_{OUT}), 1.25MHz, High Efficiency Step-Down DC/DC Converter	$V_{IN} = 3V$ to 25V, $V_{OUT} = 1.2V$, $I_Q = 1mA$, $I_{SD} = 15\mu A$, S8, TSSOP16E Packages
LT1766	60V, 1.2A (I_{OUT}), 200kHz, High Efficiency Step-Down DC/DC Converter	$V_{IN} = 5.5V$ to 60V, $V_{OUT} = 1.2V$, $I_Q = 2.5mA$, $I_{SD} = 25\mu A$, TSSOP16/E Package
LT1767	25V, 1.2A (I_{OUT}), 1.25MHz, High Efficiency Step-Down DC/DC Converter	$V_{IN} = 3V$ to 25V; $V_{OUT} = 1.2V$, $I_Q = 1mA$, $I_{SD} = 6\mu A$, MS8/E Packages
LT1776	40V, 550mA (I_{OUT}), 200kHz, High Efficiency Step-Down DC/DC Converter	$V_{IN} = 7.4V$ to 40V; $V_{OUT} = 1.24V$, $I_Q = 3.2mA$, $I_{SD} = 30\mu A$, N8, S8 Packages
LTC®1877	600mA (I_{OUT}), 550kHz, Synchronous Step-Down DC/DC Converter	$V_{IN} = 2.7V$ to 10V; $V_{OUT} = 0.8V$, $I_Q = 10\mu A$, $I_{SD} = <1\mu A$, MS8 Package
LTC1879	1.2A (I_{OUT}), 550kHz, Synchronous Step-Down DC/DC Converter	$V_{IN} = 2.7V$ to 10V; $V_{OUT} = 0.8V$, $I_Q = 15\mu A$, $I_{SD} = <1\mu A$, TSSOP16 Package
LT1956	60V, 1.2A (I_{OUT}), 500kHz, High Efficiency Step-Down DC/DC Converter	$V_{IN} = 5.5V$ to 60V, $V_{OUT} = 1.2V$, $I_Q = 2.5mA$, $I_{SD} = 25\mu A$, TSSOP16/E Package
LTC3405/LTC3405A	300mA (I_{OUT}), 1.5MHz, Synchronous Step-Down DC/DC Converter	$V_{IN} = 2.7V$ to 6V, $V_{OUT} = 0.8V$, $I_Q = 20\mu A$, $I_{SD} = <1\mu A$, ThinSOT Package
LTC3406/LTC3406B	600mA (I_{OUT}), 1.5MHz, Synchronous Step-Down DC/DC Converter	$V_{IN} = 2.5V$ to 5.5V, $V_{OUT} = 0.6V$, $I_Q = 20\mu A$, $I_{SD} = <1\mu A$, ThinSOT Package
LTC3411	1.25A (I_{OUT}), 4MHz, Synchronous Step-Down DC/DC Converter	$V_{IN} = 2.5V$ to 5.5V, $V_{OUT} = 0.8V$, $I_Q = 60\mu A$, $I_{SD} = <1\mu A$, MS Package
LTC3412	2.5A (I_{OUT}), 4MHz, Synchronous Step-Down DC/DC Converter	$V_{IN} = 2.5V$ to 5.5V, $V_{OUT} = 0.8V$, $I_Q = 60\mu A$, $I_{SD} = <1\mu A$, TSSOP16E Package
LTC3430	60V, 2.75A (I_{OUT}), 200kHz, High Efficiency Step-Down DC/DC Converter	$V_{IN} = 5.5V$ to 60V, $V_{OUT} = 1.2V$, $I_Q = 2.5mA$, $I_{SD} = 30\mu A$, TSSOP16E Package