

TOSHIBA

TMP87P808/808L

CMOS 8-Bit Microcontroller

**TMP87P808M, TMP87P808N
TMP87P808LM, TMP87P808LN**

The 87P808/808L is a high-speed, high-performance 8-bit single chip microcomputer, which has 64K bits One-Time PROM. The 87P808/808L is pin compatible with the 87C408/808/408L/808L. The operations possible with the 87C408/808/408L/808L can be performed by writing programs to PROM. The 87P808/808L can write and verify in the same way as the TC57256AD using an adapter socket and a general-purpose PROM programmer.

Part No.	ROM	RAM	Package	Adapter socket	Operation Voltage Range
TMP87P808M	8 K x 8-bit	256 x 8-bit	P-SOP28-450-1.27	BM11116	2.7 V to 5.5 V at 4.2 MHz
TMP87P808N			P-SDIP28-400-1.78	BM11122	4.5 V to 5.5 V at 8 MHz
TMP87P808LM	8 K x 8-bit	256 x 8-bit	P-SOP28-450-1.27	BM11116	1.8 V to 4.0 V at 4.2 MHz
TMP87P808LN			P-SDIP28-400-1.78	BM11122	

Pin Assignments (Top View)

P-SOP28-400-1.78 / P-SDIP28-450-1.27

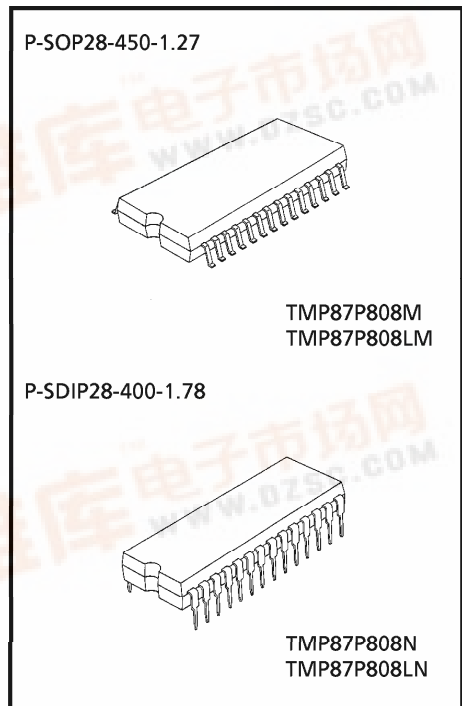
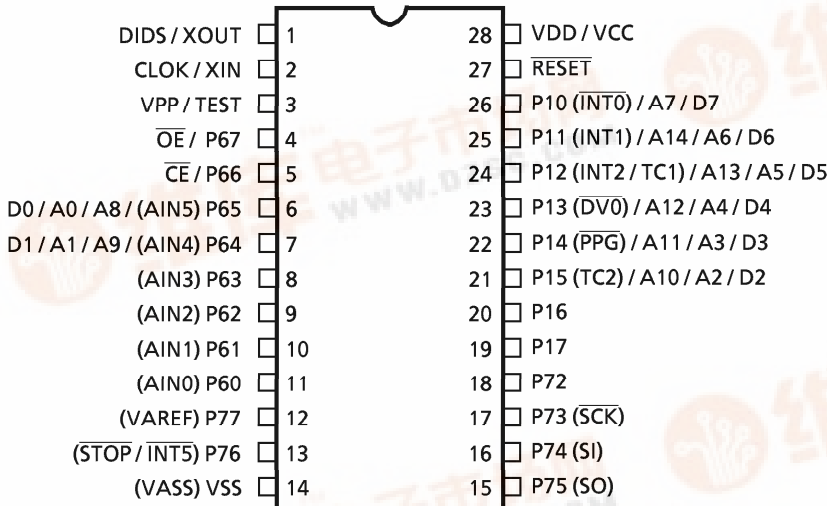

000707EBP1

- For a discussion of how the reliability of microcontrollers can be predicted, please refer to Section 1.3 of the chapter entitled Quality and Reliability Assurance / Handling Precautions.
- TOSHIBA is continually working to improve the quality and reliability of its products. Nevertheless, semiconductor devices in general can malfunction or fail due to their inherent electrical sensitivity and vulnerability to physical stress. It is the responsibility of the buyer, when utilizing TOSHIBA products, to comply with the standards of safety in making a safe design for the entire system, and to avoid situations in which a malfunction or failure of such TOSHIBA products could cause loss of human life, bodily injury or damage to property. In developing your designs, please ensure that TOSHIBA products are used within specified operating ranges as set forth in the most recent TOSHIBA products specifications. Also, please keep in mind the precautions and conditions set forth in the "Handling Guide for Semiconductor Devices," or "TOSHIBA Semiconductor Reliability Handbook" etc..
- The TOSHIBA products listed in this document are intended for usage in general electronics applications (computer, personal equipment, office equipment, measuring equipment, industrial robotics, domestic appliances, etc.). These TOSHIBA products are neither intended nor warranted for usage in equipment that requires extraordinarily high quality and/or reliability or a malfunction or failure of which may cause loss of human life or bodily injury ("Unintended Usage"). Unintended Usage include atomic energy control instruments, airplane or spaceship instruments, transportation instruments, traffic signal instruments, combustion control instruments, medical instruments, all types of safety devices, etc.. Unintended Usage of TOSHIBA products listed in this document shall be made at the customer's own risk.
- The products described in this document are subject to the foreign exchange and foreign trade laws.
- The information contained herein is presented only as a guide for the applications of our products. No responsibility is assumed by TOSHIBA CORPORATION for any infringements of intellectual property or other rights of the third parties which may result from its use. No license is granted by implication or otherwise under any intellectual property or other rights of TOSHIBA CORPORATION or others.
- The information contained herein is subject to change without notice.



Pin Function

The 87P808/808L has two modes: MCU and PROM.

(1) MCU mode

In this mode, the 87P808/808L is pin compatible with the 87C408/808/408L/808L (fix the TEST pin at low level).

(2) PROM mode

Pin Name (PROM mode)	Input / Output	Functions	Pin name (MCU mode)
A14 to A8	Input	Program memory address inputs	P10 to P15, P64, P65
A7 to A0			P10 to P15, P64, P65
D7 to D0	I/O	Program memory data input/outputs	P10 to P15, P64, P65
\overline{CE}	Input	Chip enable signal input	P66
\overline{OE}		Output enable signal input	P67
VPP	Power supply	+ 12.5 V / 5 V (Program supply voltage)	TEST
VCC		+ 5 V	VDD
GND		0 V	VSS
P17 to P16	I/O	PROM mode setting pins. Be fixed at low level.	
P63 to P60			
P77 to P72			
\overline{RESET}			
XIN	Input	Connect an 8 MHz oscillator to stabilize the internal state.	
XOUT	Output		
VAREF	Power supply	0 V (GND)	
VASS			

Operational Description

The configuration and function of the 87P808/808L are the same as those of the 87C408/808/408L/808L, except in that a one-time PROM is used instead of an on-chip mask ROM.

1. Operating Mode

The 87P808/808L has two modes: MCU and PROM.

1.1 MCU Mode

The MCU mode is activated by fixing the TEST/VPP pin at low level.

In the MCU mode, operation is the same as with the 87C408/808/408L/808L (TEST/VPP pin cannot be used open because it has no built in pull-down resistance.)

1.1.1 Program Memory

The 87P808/808L have an 8 Kbytes (addresses E000 to FFFF_H in the MCU mode, addresses 6000 to 7FFF_H in the PROM mode) one-time PROM.

When the 87P808/808L is used as a system evaluation of the 87C408/808/408L/808L, the data is written to the program storage area shown in Figure 1-1.

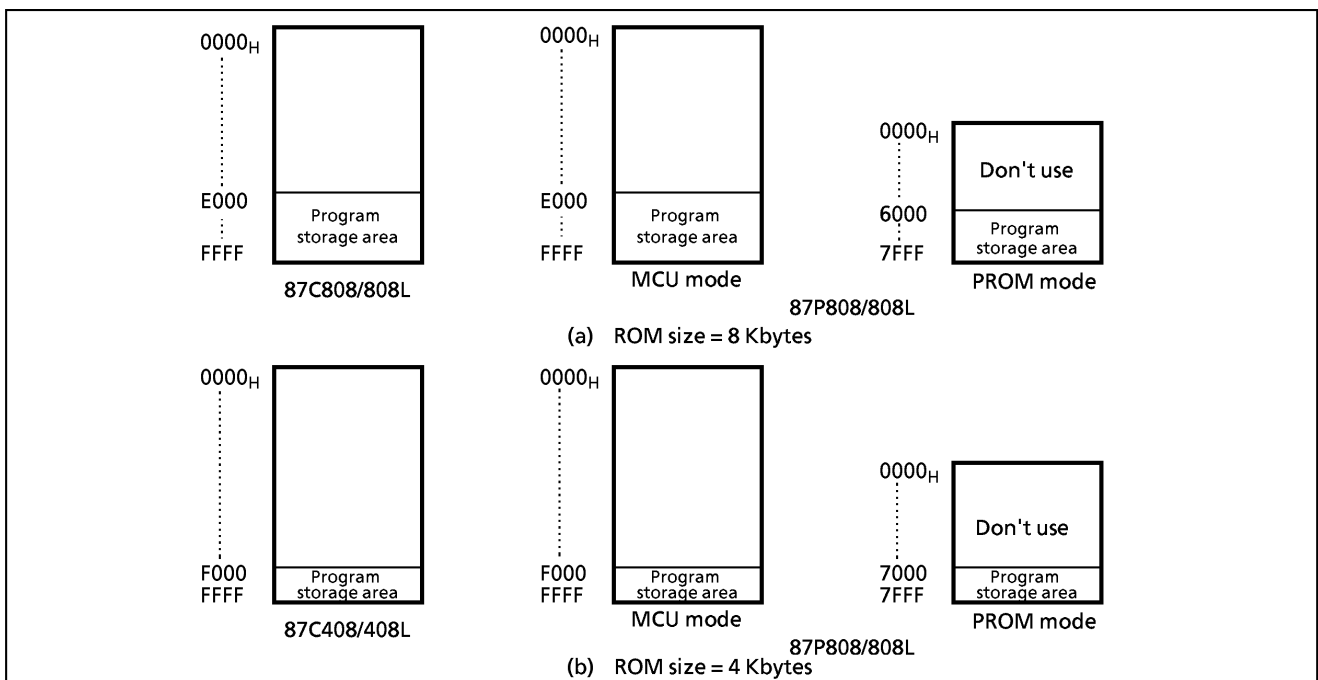

Figure 1-1. Program Memory Area

Note: Either write the data FFH to the unused area or set the general-purpose PROM programmer to access only the program storage area

1.1.2 Data Memory

The 87P808/808L has an 256 bytes data memory (static RAM).

Electrical Characteristics

(1) 87P808

Absolute Maximum Ratings

 $(V_{SS} = 0\text{ V})$

Parameter	Symbol	Conditions	Ratings	Unit	
Supply Voltage	V_{DD}		- 0.3 to 6.5	V	
Program Voltage	V_{PP}	TEST / V_{PP} pin	- 0.3 to 13.0	V	
Input Voltage	V_{IN}		- 0.3 to $V_{DD} + 0.3$	V	
Output Voltage	V_{OUT}		- 0.3 to $V_{DD} + 0.3$	V	
Output Current (Per 1 pin)	IOL	I_{OUT1}	P1, P6	3.2	mA
		I_{OUT2}	P7 (Middle current port)	15	mA
	IOH	I_{OUT3}	P1, P6, P7	- 1.8	mA
Output Current (Total)	IOL	ΣI_{OUT1}	P1, P6	50	mA
		ΣI_{OUT2}	P7 (Middle current port)	60	mA
	IOH	ΣI_{OUT3}	P1, P6, P7	30	mA
Power Dissipation [Topr = 70°C]	PD	SDIP	300	mW	
		SOP	180		
Soldering Temperature (time)	Tsld		260 (10 s)	°C	
Storage Temperature	Tstg		- 55 to 125	°C	
Operating Temperature	Topr		- 30 to 70	°C	

Note: The absolute maximum ratings are rated values which must not be exceeded during operation, even for an instant. Any one of the ratings must not be exceeded. If any absolute maximum rating is exceeded, a device may break down or its performance may be degraded, causing it to catch fire or explode resulting in injury to the user. Thus, when designing products which include this device, ensure that no absolute maximum rating value will ever be exceeded.

Recommended Operating Conditions

 $(V_{SS} = 0\text{ V}, \text{Topr} = -30\text{ to }70^\circ\text{C})$

Parameter	Symbol	Pins	Conditions	Min	Max	Unit	
Supply Voltage	V_{DD}		$f_c = 8\text{ MHz}$	NORMAL mode	4.5	5.5	V
				IDLE mode			
			$f_c = 4.2\text{ MHz}$	NORMAL mode	2.7		
				IDLE mode			
Input High Voltage	V_{IH1}	Except hysteresis input	$V_{DD} \geq 4.5\text{ V}$	$V_{DD} \times 0.70$	V_{DD}	V	
	V_{IH2}	Hysteresis input		$V_{DD} \times 0.75$			
	V_{IH3}		$2.7\text{ V} \leq V_D < 4.5\text{ V}$	$V_{DD} \times 0.90$			
	V_{IH4}		$V_{DD} < 2.7\text{ V}$	$V_{DD} \times 0.95$			
Input Low Voltage	V_{IL1}	Except hysteresis input	$V_{DD} \geq 4.5\text{ V}$	0	$V_{DD} \times 0.30$	V	
	V_{IL2}	Hysteresis input		$V_{DD} \times 0.25$			
	V_{IL3}		$2.7\text{ V} \leq V_{DD} < 4.5\text{ V}$	$V_{DD} \times 0.10$			
Clock Frequency	f_c	XIN, XOUT	$V_{DD} = 4.5\text{ to }5.5\text{ V}$	1.0	8.0	MHz	
			$V_{DD} = 2.7\text{ to }5.5\text{ V}$		4.2		

Note 1: The recommended operating conditions for a device are operating conditions under which it can be guaranteed that the device will operate as specified. If the device is used under operating conditions other than the recommended operating conditions (supply voltage, operating temperature range, specified AC/DC values etc.), malfunction may occur. Thus, when designing products which include this device, ensure that the recommended operating conditions for the device are always adhered to.

Note 2: Clock frequency f_c : Supply voltage range is specified in NORMAL mode and IDLE mode.

Note 3: Minimum of clock frequency: $1\text{ MHz} \leq f_{c\text{gk}}$

D.C. Characteristics

(V_{SS} = 0 V, T_{opr} = -30 to 70°C)

Parameter	Symbol	PINS	Conditions	Min	Typ.	Max	Unit		
Hysteresis Voltage	V _{HS}	Hysteresis inputs		-	0.9	-	V		
Input Current	I _{IN1}	TEST	V _{DD} = 5.5 V V _{IN} = 5.5 V / 0 V	-2	-	2	μA		
	I _{IN2}	Tri-state ports							
	I _{IN3}	RESET, STOP							
Input Resistance	R _{IN1}	TEST		30	70	150	kΩ		
	R _{IN2}	RESET		100	220	450			
	R _{IN3}	STOP _i	i = 2 to 5	30	130	250			
Output Leak Current	I _{LO}	Tri-state ports	V _{DD} = 5.5 V, V _{OUT} = 5.5 V / 0V	-2	-	2	μA		
Output High Voltage	V _{OH2}	Tri-state ports Ports P1, P6	V _{DD} = 4.5 V, I _{OH} = -0.7 mA	4.1	-	-	V		
Low Output Voltage	V _{OL}	Except XOUT and P7	V _{DD} = 4.5 V, I _{OL} = 1.6 mA	-	-	0.4	V		
Low Output Current	I _{OL3}	P7	V _{DD} = 4.5 V, V _{OL} = 1.0 V	-	7	-	mA		
Supply Current in NORMAL mode	I _{DD}		V _{DD} = 5.5 V fc = 8 MHz V _{IN} = 5.3 V / 0.2V	fcgck	fc	-	7.0	11	mA
Supply Current in IDLE mode					fc/2	-	4.4	7.0	
					fc/4	-	2.8	5.1	
					fc/8	-	2.2	4.5	
				fcgck	fc	-	3.6	5.5	
fc/2					-	2.6	4.2		
fc/4			-		2.0	3.7			
Supply Current in NORMAL mode			V _{DD} = 3.0 V fc = 4.19 MHz V _{IN} = 2.8 V / 0.2V	fcgck	fc	-	1.7	2.8	
					fc/2	-	1.1	2.0	
					fc/4	-	0.7	1.4	
Supply Current in IDLE mode				fcgck	fc	-	0.9	1.6	
					fc/2	-	0.7	1.4	
	fc/4	-			0.5	1.0			
Supply Current in STOP mode			V _{DD} = 5.5 V V _{IN} = 5.3 V / 0.2 V	-	0.5	10	μA		

Note 1: Typical values show those at T_{opr} = 25°C, V_{DD} = 5 V.

Note 2: Input Current I_{IN1}, I_{IN3}: The current through resistor is not included, when the input resistor (pull-up or pull-down) is contained.

Note 3: I_{DD}; Except for I_{REF}

A/D Conversion Characteristics

(V_{SS} = 0 V, V_{DD} = 2.7 to 5.5V, T_{opr} = -30 to 70°C)

Parameter	Symbol	Conditions	Min	Typ.	Max	Unit
Analog Reference Voltage	V _{AREF}		2.7	-	V _{DD}	V
	V _{ASS}		V _{SS}			
Analog Input Voltage Range	V _{AIN}		V _{ASS}	-	V _{AREF}	V
Analog Reference Current	I _{REF}	V _{AREF} = 5.5 V, V _{ASS} (V _{SS}) = 0.0 V	-	0.8	1.0	mA
Nonlinearity Error		V _{DD} = 5.0 V, V _{AREF} = 5.000 V V _{ASS} (V _{SS}) = 0.000 V	-	-	± 1	LSB
Zero Point Error		or	-	-	± 1	
Full Scale Error		V _{DD} = 2.7 V, V _{AREF} = 2.700 V V _{ASS} (V _{SS}) = 0.000 V	-	-	± 1	
Total Error			-	-	± 2	

Note: Quantizing error is not contained in those errors.

A.C. Characteristics (I)

(V_{SS} = 0 V, V_{DD} = 4.5 to 5.5 V, Topr = -30 to 70°C)

Parameter	Symbol	Conditions	Min	Typ.	Max	Unit
Machine Cycle Timer	t _{cy}	In NORMAL mode	0.5	-	4	μs
		In IDLE mode				
High Level Clock Pulse Width	t _{WCH}	For external clock operation f _c = 8 MHz	50	-	-	ns
Low Level Clock Pulse Width	t _{WCL}					
A/D Conversion Time	t _{ADC}	ACK = 0	-	46	-	t _{cy}
		ACK = 1		184		
A/D Sampling Time	t _{AIN}		-	4	-	

A.C. Characteristics (II)

(V_{SS} = 0 V, V_{DD} = 2.7 to 5.5 V, Topr = -30 to 70°C)

Parameter	Symbol	Conditions	Min	Typ.	Max	Unit
Machine Cycle Time	t _{cy}	In NORMAL mode	0.95	-	4	μs
		In IDLE mode				
High Level Clock Pulse Width	t _{WCH}	For external clock operation f _c = 4.2 MHz	110	-	-	ns
Low Level Clock Pulse Width	t _{WCL}					
A/D Conversion Time	t _{ADC}	ACK = 0	-	46	-	t _{cy}
		ACK = 1		184		
A/D Sampling Time	t _{AIN}		-	4		

Note: A/D conversion timing:
Internal circuit for AIN0 to 5

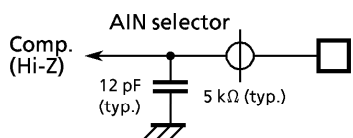

※ To maintain a precision of A/D conversion, internal condenser must be charged until t_{AIN} is over.

A/D conversion timing

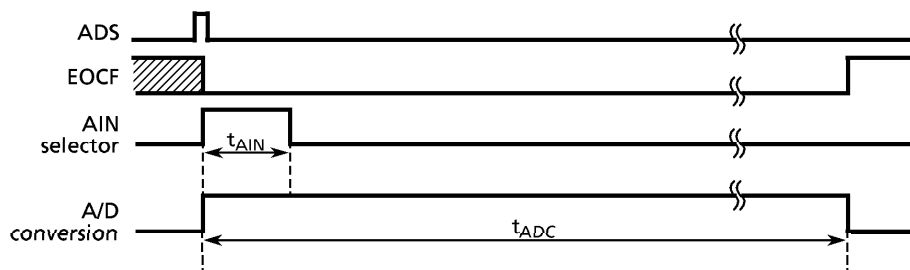

Recommended Oscillating Conditions (I)

(V_{SS} = 0 V, V_{DD} = 4.5 to 5.5 V, Topr = - 30 to 70°C)

Parameter	Oscillator	Oscillation Frequency	Recommended Oscillator	Recommended Conditions	
				C ₁	C ₂
High-frequency Oscillation	Ceramic Resonator	8 MHz (VDD = 4.5 to 5.5 V)	KYOCERA KBR8.0M	30 pF	30 pF
			MURATA CSAC8.00MT	30 pF	30 pF
			MURATA CSA8.00MTZ CST8.00MTW CSTS8.00MT	—	—
	Ceramic Resonator	4.19 MHz (VDD = 2.7 to 5.5 V)	MURATA CSA4.19MG	30 pF	30 pF
			MURATA CST4.19MGW	—	—
			KYOCERA KBR4.0MS	30 pF	30 pF
Crystal Oscillator	8 MHz (VDD = 4.5 to 5.5 V)	TOYOCOM 210B 8.0000	20 pF	20 pF	
		4 MHz (VDD = 2.7 to 5.5 V)			TOYOCOM 204B 4.000

Recommended Oscillating Conditions (II)

(V_{SS} = 0 V, V_{DD} = 2.7 to 5.5 V, Topr = - 30 to 70°C)

Parameter	Oscillator	Oscillation Frequency	Recommended Oscillator	Recommended Conditions	
				C ₁	C ₂
High-frequency Oscillation	Ceramic Resonator	4.19 MHz (VDD = 2.7 to 5.5 V)	MURATA CSA4.19MG	30 pF	30 pF
			MURATA CST4.19MGW	—	—
		4 MHz (VDD = 2.7 to 5.5 V)	MURATA CSA4.00MG CSA4.00MGC	30 pF	30 pF
			MURATA CST4.00MGW CSTC4.00MG	—	—
			MURATA CSTCS4.00MG	—	—
			—	—	—

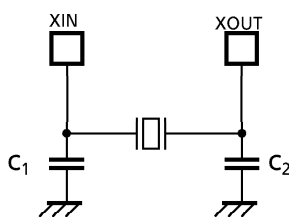

(1) High-frequency Oscillation

Note: When used in high electric field such as a picture tube, the package is recommended to be electrically shielded to maintain a regular operation.

D.C. Characteristics, A.C. Characteristics

($V_{SS} = 0\text{ V}$)

(1) Read Operation ($T_{opr} = 0\text{ to }70^\circ\text{C}$)

Parameter	Symbol	Conditions	Min	Typ.	Max	Unit
Input High Voltage	V_{IH4}		$V_{CC} \times 0.67$	–	V_{CC}	V
Input Low Voltage	V_{IL4}		0	–	$V_{CC} \times 0.3$	V
Supply Voltage	V_{CC}		4.75	5.00	5.25	V
Program Supply Voltage	V_{PP}		$V_{CC} - 0.6$	V_{CC}	$V_{CC} + 0.6$	
Address Set-up Time	t_{ASU}		400	–	–	ns
Address Access Time	t_{ACC}	$V_{CC} = 5.0 \pm 0.25\text{ V}$	–	5tcyc	–	ns

Note: tcyc = 400 ns

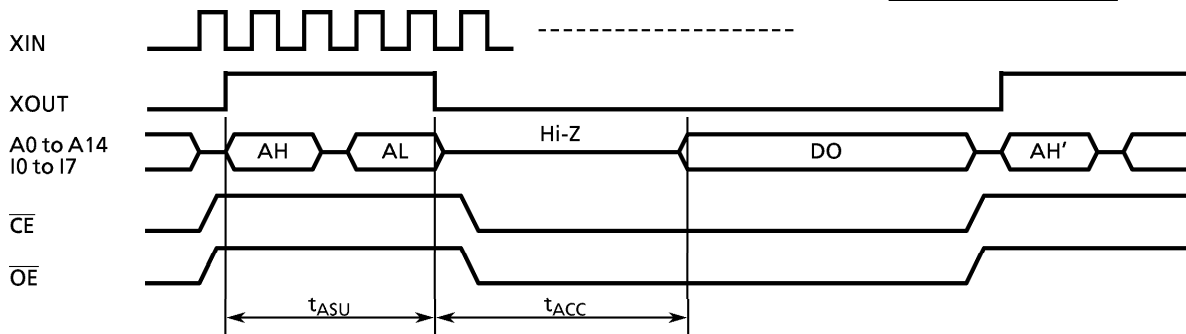

(2) Program Operation (High speed write mode - I) ($T_{opr} = 25 \pm 5^\circ\text{C}$)

Parameter	Symbol	Conditions	Min	Typ.	Max	Unit
Input High Voltage	V_{IH4}		$V_{CC} \times 0.7$	–	V_{CC}	V
Input Low Voltage	V_{IL4}		0	–	$V_{CC} \times 0.12$	V
Supply Voltage	V_{CC}		5.75	6.0	6.25	V
Program Supply Voltage	V_{PP}		12.0	12.5	13.0	V
Initial Program Pulse Width	t_{PW}	$V_{CC} = 6.0\text{ V} \pm 0.25\text{ V}$, $V_{PP} = 12.5\text{ V} \pm 0.25\text{ V}$	0.95	1.0	1.05	ms

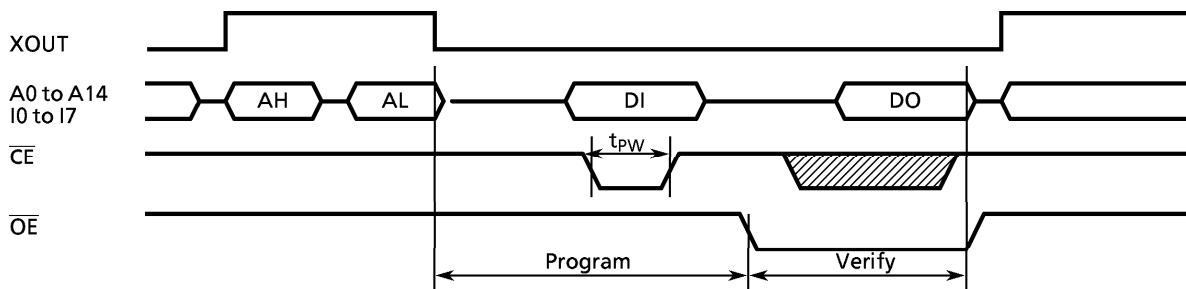

Note: DO ; Data output (I0 to I7) AL ; Address input (A0 to A7)
DI ; Data input (I0 to I7) AH ; Address input (A8 to A14)

- Note 1: When V_{CC} power supply is turned on or after, V_{PP} must be increased.
When V_{CC} power supply is turned off or before, V_{PP} must be decreased.
- Note 2: The device must not be set to the EPROM programmer or picked up from it under applying the program voltage ($12.5\text{ V} \pm 0.5\text{ V}$) to the V_{PP} pin as the device is damaged.
- Note 3: Be sure to execute the recommended programing mode with the recommended programing adaptor. If a mode or an adaptor except the above, the misoperation sometimes occurs.

(3) Program Operation (High speed write mode - II) ($T_{opr} = 25 \pm 5^{\circ}\text{C}$)

Parameter	Symbol	Conditions	Min	Typ.	Max	Unit
Input High Voltage	V_{IH4}		$V_{CC} \times 0.7$	–	V_{CC}	V
Input Low Voltage	V_{IL4}		0	–	$V_{CC} \times 0.12$	V
Supply Voltage	V_{CC}		6.00	6.25	6.50	V
Program Supply Voltage	V_{PP}		12.50	12.75	13.0	V
Initial Program Pulse Width	t_{PW}	$V_{CC} = 6.25 \text{ V} \pm 0.25 \text{ V}$, $V_{PP} = 12.75 \text{ V} \pm 0.25 \text{ V}$	0.095	0.1	0.105	ms

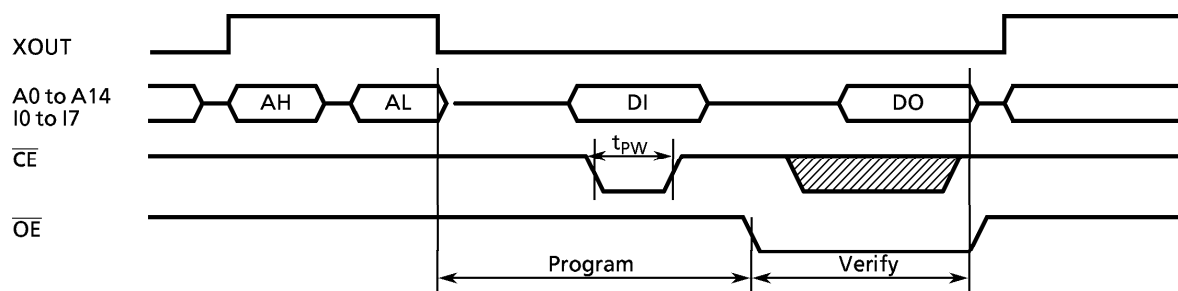

Note: DO ; Data output (I0 to I7) AL ; Address input (A0 to A7)
 DI ; Data input (I0 to I7) AH ; Address input (A8 to A14)

- Note 1: When V_{CC} power supply is turned on or after, V_{pp} must be increased.
 When V_{CC} power supply is turned off or before, V_{pp} must be decreased.*
- Note 2: The device must not be set to the EPROM programmer or picked up from it under applying the program voltage ($12.5 \text{ V} \pm 0.5 \text{ V}$) to the V_{pp} pin as the device is damaged.*
- Note 3: Be sure to execute the recommended programming mode with the recommended programming adaptor. If a mode or an adaptor except the above, the misoperation sometimes occurs.*

Recommended EPROM Programmer

- | | |
|-----------|--------------------------------|
| DATA I/O | UNISTTE (SITE40) |
| ADVANTEST | R4945A |
| AVAL DATA | PECKER11 MARK-II (version 5.5) |

Electrical Characteristics

(1) 87P808L

Absolute Maximum Ratings

 $(V_{SS} = 0\text{ V})$

Parameter	Symbol	Conditions	Ratings	Unit	
Supply Voltage	V_{DD}		- 0.3 to 6.5	V	
Program Voltage	V_{PP}	TEST / V_{PP} pin	- 0.3 to 13.0	V	
Input Voltage	V_{IN}		- 0.3 to $V_{DD} + 0.3$	V	
Output Voltage	V_{OUT}		- 0.3 to $V_{DD} + 0.3$	V	
Output Current (Per 1 pin)	IOL	I_{OUT1}	P1, P6	3.2	mA
		I_{OUT2}	P7 (Middle current port)	15	mA
	IOL	I_{OUT3}	P1, P6, P7	- 1.8	mA
Output Current (Total)	IOL	ΣI_{OUT1}	P1, P6	50	mA
		ΣI_{OUT2}	P7 (Middle current port)	60	mA
	IOL	ΣI_{OUT3}	P1, P6, P7	30	mA
Power Dissipation [Topr = 70°C]	PD		SDIP	300	mW
			SOP	180	
Soldering Temperature (time)	Tsld		260 (10 s)	°C	
Storage Temperature	Tstg		- 55 to 125	°C	
Operating Temperature	Topr		- 30 to 70	°C	

Note: The absolute maximum ratings are rated values which must not be exceeded during operation, even for an instant. Any one of the ratings must not be exceeded. If any absolute maximum rating is exceeded, a device may break down or its performance may be degraded, causing it to catch fire or explode resulting in injury to the user. Thus, when designing products which include this device, ensure that no absolute maximum rating value will ever be exceeded.

Recommended Operating Conditions

 $(V_{SS} = 0\text{ V}, \text{Topr} = -30\text{ to }70^\circ\text{C})$

Parameter	Symbol	Pins	Conditions	Min	Max	Unit	
Supply Voltage	V_{DD}		$f_c = 4.2\text{ MHz}$	NORMAL mode	1.8	4.0	V
				IDLE mode			
				STOP mode			
Input High Voltage	V_{IH}			$V_{DD} \times 0.90$	V_{DD}	V	
Input Low Voltage	V_{IL}			0	$V_{DD} \times 0.10$	V	
Clock Frequency	f_c	XIN, XOUT	$V_{DD} = 1.8\text{ to }4.0\text{ V}$	1.0	4.2	MHz	

Note 1: The recommended operating conditions for a device are operating conditions under which it can be guaranteed that the device will operate as specified. If the device is used under operating conditions other than the recommended operating conditions (supply voltage, operating temperature range, specified AC/DC values etc.), malfunction may occur. Thus, when designing products which include this device, ensure that the recommended operating conditions for the device are always adhered to.

Note 2: Clock frequency f_c : Supply voltage range is specified in NORMAL mode and IDLE mode.

Note 3: Minimum of clock frequency: $1\text{ MHz} \leq f_{cgck}$

D.C. Characteristics

(V_{SS} = 0 V, Topr = - 30 to 70°C)

Parameter	Symbol	PINS	Conditions	Min	Typ.	Max	Unit			
Hysteresis Voltage	V _{HS}	Hysteresis inputs		-	0.9	-	V			
Input Current	I _{IN1}	TEST	V _{DD} = 4.0 V V _{IN} = 4.0 V / 0 V	-2	-	2	μA			
	I _{IN2}	Tri-state ports								
	I _{IN3}	RESET, STOP								
Input Resistance	R _{IN1}	TEST	i = 2 to 5	30	70	150	kΩ			
	R _{IN2}	RESET		100	220	450				
	R _{IN3}	STOPi		30	130	250				
Output Leak Current	I _{LO}	Tri-state ports	V _{DD} = 4.0 V, V _{OUT} = 4.0 V / 0V	-2	-	2	μA			
Output High Voltage	V _{OH2}	Tri-state ports	V _{DD} = 4.0 V, I _{OH} = - 0.5 mA	3.6	-	-	V			
Output Low Voltage	V _{OL}	Except XOUT and P7	V _{DD} = 4.0V, I _{OL} = 1.3 mA	-	-	0.4	V			
Output Low Current	I _{OL3}	P7	V _{DD} = 4.0 V, V _{OL} = 1.0 V	-	6	-	mA			
Supply Current in NORMAL mode	I _{DD}		V _{DD} = 4 V fc = 4.19 MHz V _{IN} = 3.8 V / 0.2V	fcgck	fc	-	2.25	3.6	mA	
Supply Current in IDLE mode					fcgck	fc/2	-	1.35		2.5
						fc/4	-	0.9		1.9
Supply Current in NORMAL mode					fcgck	fc/8	-	0.7		1.65
				fc		-	1.2	1.9		
Supply Current in IDLE mode				fcgck	fc/2	-	0.9	1.7		
					fc/4	-	0.7	1.5		
Supply Current in NORMAL mode				fcgck	fc/8	-	0.6	1.4		
			fc		-	1.5	2.5			
Supply Current in IDLE mode			fcgck	fc/2	-	0.85	1.6			
				fc/4	-	0.6	1.2			
Supply Current in NORMAL mode			fcgck	fc/8	-	0.4	1.0			
				fc	-	0.8	1.4			
Supply Current in IDLE mode			fcgck	fc/2	-	0.55	1.1			
	fc/4	-		0.45	0.9					
Supply Current in NORMAL mode	fcgck	fc/8	-	0.35	0.85					
		fc	-	0.9	1.3					
Supply Current in IDLE mode	fcgck	fc/2	-	0.5	0.8					
		fc/4	-	0.3	0.45					
Supply Current in NORMAL mode	fcgck	fc/8	-	0.2	0.35					
		fc	-	0.35	0.5					
Supply Current in IDLE mode	fcgck	fc/2	-	0.23	0.35					
		fc/4	-	0.17	0.26					
Supply Current in NORMAL mode	fcgck	fc/8	-	0.14	0.24					
		fc	-	0.35	0.5					
Supply Current in STOP mode			V _{DD} = 4.0 V V _{IN} = 3.8 V / 0.2 V	-	0.5	10	μA			

Note 1: Typical values show those at Topr = 25°C, VDD = 4 V.

Note 2: Input Current I_{IN1}, I_{IN3}: The current through resistor is not included, when the input resistor (pull-up or pull-down) is contained.

Note3: I_{DD} ; Except for I_{REF}

A/D Conversion Characteristics (I)

(V_{DD} = 1.8 to 4.0 V, T_{opr} = -30 to 70°C, V_{SS} = 0V)

Parameter	Symbol	Conditions	Min	Typ.	Max	Unit
Analog Reference Voltage	V _{AREF}		1.8	-	V _{DD}	V
	V _{ASS}		V _{SS}			
Analog Input Voltage Range	V _{AIN}		V _{ASS}	-	V _{AREF}	V
Nonlinearity Error		1.8 V ≤ V _{AREF} < 2.7 V V _{AREF} ≤ V _{DD} ≤ 4.0 V _{ASS} (V _{SS}) = 0.000V ACK = 1 (Note2)	-	-	± 2	LSB
Zero Point Error			-	-	± 2	
Full Scale Error			-	-	± 2	
Total Error			-	-	± 4	

Note1: Quantizing error is not contained in those errors.**Note2:** ACK ; bit5 of ADCCR (#000E_H). conversion time = 184 tcy (175.6 μs / at fcgck = 4.19 MHz)

A/D Conversion Characteristics (II)

(V_{SS} = 0V, V_{DD} = 2.7 to 4.0 V, T_{opr} = -30 to 70°C)

Parameter	Symbol	Conditions	Min	Typ.	Max	Unit
Analog Reference Voltage	V _{AREF}		2.7	-	V _{DD}	V
	V _{ASS}		V _{SS}			
Analog Input Voltage Range	V _{AIN}		V _{ASS}	-	V _{AREF}	V
Analog Reference Current	I _{REF}	V _{AREF} = 4.0V, V _{ASS} (V _{SS}) = 0.0V	-	0.5	1.0	mA
Nonlinearity Error		V _{DD} = 4.0 V V _{AREF} = 4.000V V _{ASS} (V _{SS}) = 0.000V or V _{DD} = 2.7 V V _{AREF} = 2.700V V _{ASS} (V _{SS}) = 0.000V	-	-	± 1	LSB
Zero Point Error			-	-	± 1	
Full Scale Error			-	-	± 1	
Total Error			-	-	± 2	

Note: Quantizing error is not contained in those errors.

A.C. Characteristics

(V_{SS} = 0 V, V_{DD} = 1.8 to 4.0 V, T_{opr} = -30 to 70°C)

Parameter	Symbol	Conditions	Min	Typ.	Max	Unit
Machine Cycle Time	t _{cy}	In NORMAL mode	0.95	-	4	μs
		In IDLE mode				
High Level Clock Pulse Width	t _{WCH}	For external clock operation f _c = 4.2 MHz	110	-	-	ns
Low Level Clock Pulse Width	t _{WCL}					
A/D Conversion Time	t _{ADC}	ACK = 0	-	46	-	t _{cy}
		ACK = 1		184		
A/D Sampling Time	t _{AIN}		-	4		

Note: A/D conversion timing:
Internal circuit for AIN 0 to 5

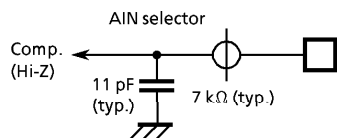

※ To maintain a precision of A/D conversion, internal condenser must be charged until t_{AIN} is over.

A/D conversion timing

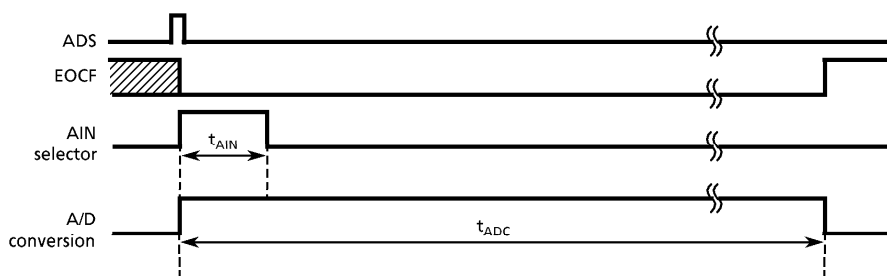

Recommended Oscillating Conditions

(V_{SS} = 0 V, T_{opr} = - 30 to 70°C)

Parameter	Oscillator	Oscillation Frequency	Recommended Oscillator	Recommended Conditions	
				C ₁	C ₂
High-frequency Oscillation	Ceramic Resonator	4.19 MHz (VDD = 2.7 to 5.5 V)	MURATA CSA4.19MG	30 pF	30 pF
			MURATA CST4.19MGW	—	—
		4 MHz (VDD = 2.7 to 5.5 V)	MURATA CSA4.00MG	30 pF	30 pF
			MURATA CSA4.00MGC	—	—
			MURATA CST4.00MGW	—	—
			MURATA CSTC4.00MG	—	—
MURATA CSTCS4.00MG	—	—			

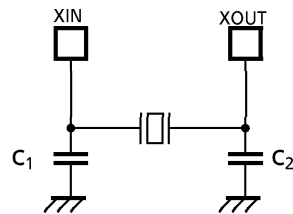

(1) High-frequency Oscillation

Note: When used in high electric field such as a picture tube, the package is recommended to be electrically shielded to maintain a regular operation.

D.C. Characteristics, A.C. Characteristics

(V_{SS} = 0 V)

(1) Read Operation (T_{opr} = 0 to 70°C)

Parameter	Symbol	Conditions	Min	Typ.	Max	Unit
Input High Voltage	V _{IH4}		V _{CC} × 0.67	–	V _{CC}	V
Input Low Voltage	V _{IL4}		0	–	V _{CC} × 0.3	V
Supply Voltage	V _{CC}		4.75	5.00	5.25	V
Program Supply Voltage	V _{PP}		V _{CC} – 0.6	V _{CC}	V _{CC} + 0.6	
Address Set-up Time	t _{ASU}		400	–	–	ns
Address Access Time	t _{ACC}	V _{CC} = 5.0 ± 0.25 V	–	5tcyc	–	ns

Note: tcyc = 400 ns

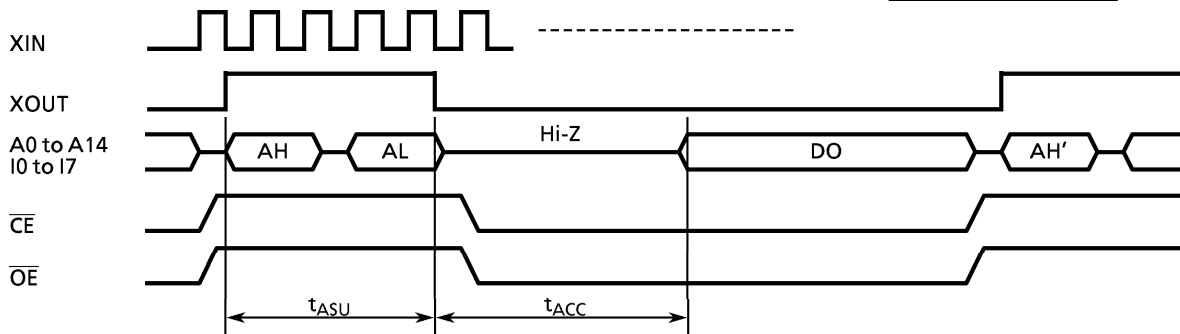

(2) Program Operation (High speed write mode - I) (T_{opr} = 25 ± 5°C)

Parameter	Symbol	Conditions	Min	Typ.	Max	Unit
Input High Voltage	V _{IH4}		V _{CC} × 0.7	–	V _{CC}	V
Input Low Voltage	V _{IL4}		0	–	V _{CC} × 0.12	V
Supply Voltage	V _{CC}		5.75	6.0	6.25	V
Program Supply Voltage	V _{PP}		12.0	12.5	13.0	V
Initial Program Pulse Width	t _{PW}	V _{CC} = 6.0 V ± 0.25 V, V _{PP} = 12.5 V ± 0.25 V	0.95	1.0	1.05	ms

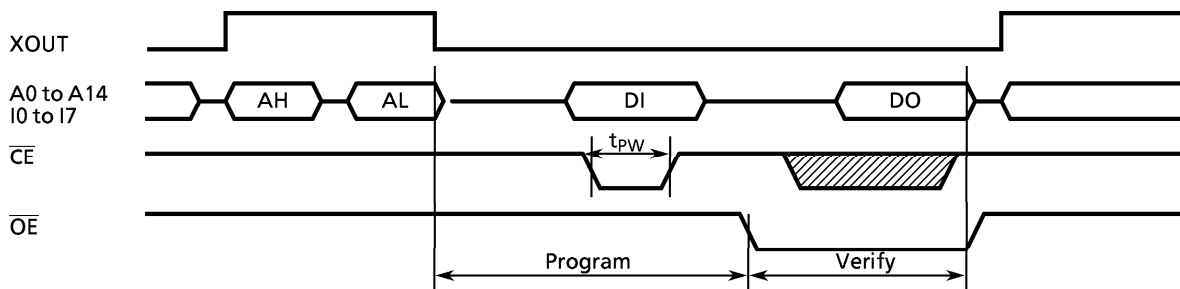

Note: DO ; Data output (I0 to I7) AL ; Address input (A0 to A7)
DI ; Data input (I0 to I7) AH ; Address input (A8 to A14)

- Note 1: When V_{CC} power supply is turned on or after, V_{PP} must be increased. When V_{CC} power supply is turned off or before, V_{PP} must be decreased.
- Note 2: The device must not be set to the EPROM programmer or picked up from it under applying the program voltage (12.5 V ± 0.5 V) to the V_{PP} pin as the device is damaged.
- Note 3: Be sure to execute the recommended programing mode with the recommended programing adaptor. If a mode or an adaptor except the above, the misoperation sometimes occurs.

(3) Program Operation (High speed write mode - II) ($T_{opr} = 25 \pm 5^{\circ}\text{C}$)

Parameter	Symbol	Conditions	Min	Typ.	Max	Unit
Input High Voltage	V_{IH4}		$V_{CC} \times 0.7$	-	V_{CC}	V
Input Low Voltage	V_{IL4}		0	-	$V_{CC} \times 0.12$	V
Supply Voltage	V_{CC}		6.00	6.25	6.50	V
Program Supply Voltage	V_{PP}		12.50	12.75	13.0	V
Initial Program Pulse Width	t_{PW}	$V_{CC} = 6.25\text{ V} \pm 0.25\text{ V}$, $V_{PP} = 12.75\text{ V} \pm 0.25\text{ V}$	0.095	0.1	0.105	ms

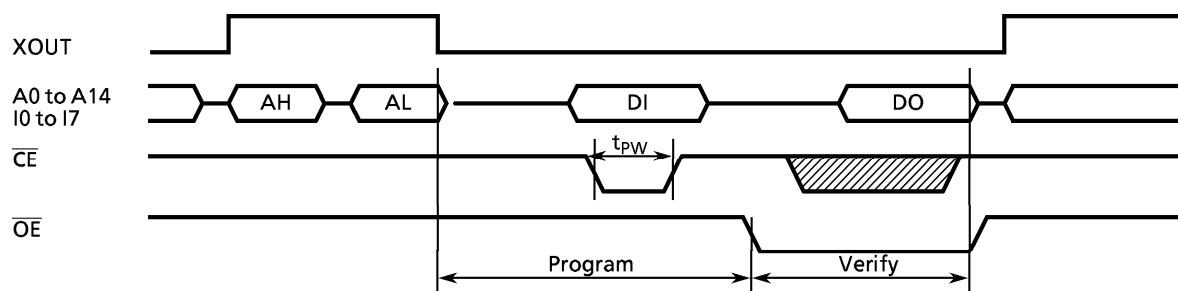

Note: DO ; Data output (I0 to I7) AL ; Address input (A0 to A7)
 DI ; Data input (I0 to I7) AH ; Address input (A8 to A14)

- Note1: When V_{CC} power supply is turned on or after, V_{PP} must be increased.
 When V_{CC} power supply is turned off or before, V_{PP} must be decreased.
- Note2: The device must not be set to the EPROM programmer or picked up from it under applying the program voltage ($12.5\text{ V} \pm 0.5\text{ V}$) to the V_{PP} pin as the device is damaged.
- Note3: Be sure to execute the recommended programming mode with the recommended programming adaptor. If a mode or an adaptor except the above, the misoperation sometimes occurs.

Recommended EPROM Programmer

DATA I/O UNISTTE (SITE40)
 ADVANTEST R4945A
 AVAL DATA PECKER11 MARK-II (version 5.5)