



Features

- Low power consumption
- Low voltage drop
- Low temperature coefficient
- High input voltage (up to 24V)
- High output current : 100mA ($P_d \leq 250mW$)
- Output voltage accuracy: tolerance $\pm 3\%$
- TO-92, SOT-89 and SOT-25 package

Applications

- Battery-powered equipment
- Communication equipment
- Audio/Video equipment

General Description

The HT75XX-1 series is a set of three-terminal high current low voltage regulator implemented in CMOS technology. They can deliver 100mA output current and allow an input voltage as high as 24V. They are available with several fixed output voltages ranging from 3.0V to 5.0V. CMOS technology ensures low voltage drop and low quiescent current.

Although designed primarily as fixed voltage regulators, these devices can be used with external components to obtain variable voltages and currents.

Selection Table

Part No.	Output Voltage	Tolerance	Package	Marking
HT7530-1	3.0V	$\pm 3\%$	TO-92 SOT-89 SOT-25	75XX-1 (for TO-92) 75XX-1 (for SOT-89) 5XX1 (for SOT-25)
HT7533-1	3.3V	$\pm 3\%$		
HT7536-1	3.6V	$\pm 3\%$		
HT7544-1	4.4V	$\pm 3\%$		
HT7550-1	5.0V	$\pm 3\%$		

Note: "XX" stands for output voltages.

Block Diagram

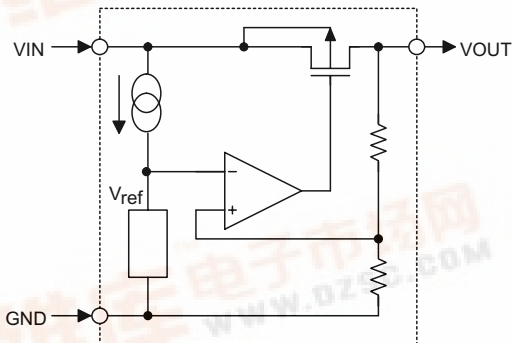

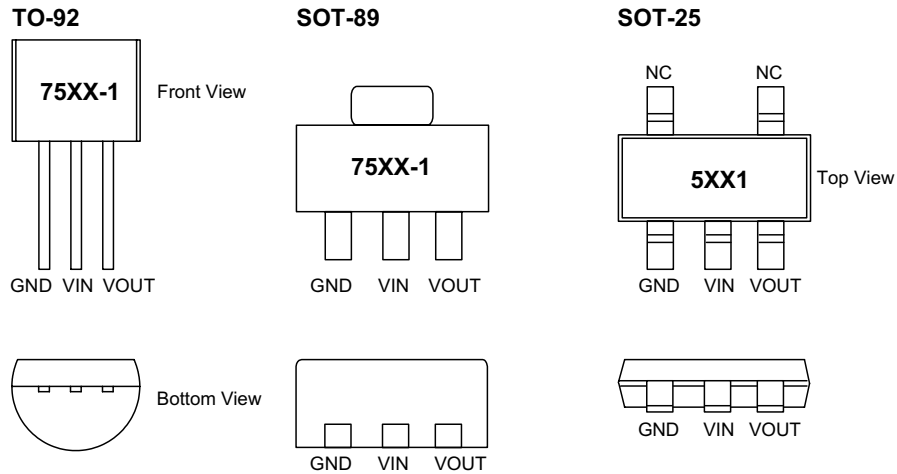
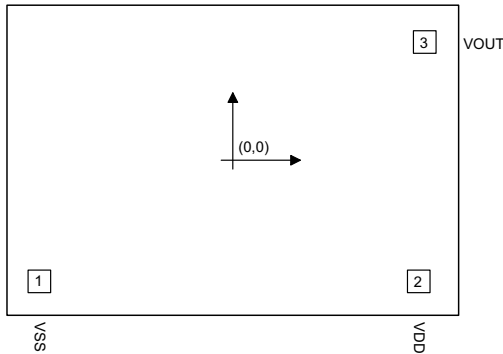
Pin Assignment

Pad Assignment

Pad Coordinates

 Unit: μm

Pad No.	X	Y
1	-639.00	-406.00
2	618.50	-406.00
3	641.85	392.10

 Chip size: $1540 \times 1070 (\mu\text{m})^2$

*The IC substrate should be connected to VDD in the PCB layout artwork.

Absolute Maximum Ratings

Supply Voltage	-0.3V to 26V	Storage Temperature	-50°C to 125°C
Power Consumption (*1)	250mW	Operating Temperature	0°C to 70°C
Power Consumption (*2)	150mW		

Note: These are stress ratings only. Stresses exceeding the range specified under "Absolute Maximum Ratings" may cause substantial damage to the device. Functional operation of this device at other conditions beyond those listed in the specification is not implied and prolonged exposure to extreme conditions may affect device reliability.

*1: applied to SOT89 and TO-92

*2: applied to SOT-25

Electrical Characteristics
HT7530-1, +3.0V output type

Ta=25°C

Symbol	Parameter	Test Conditions		Min.	Typ.	Max.	Unit
		V _{IN}	Conditions				
V _{OUT}	Output Voltage Tolerance	5V	I _{OUT} =10mA	2.91	3.0	3.09	V
I _{OUT}	Output Current	5V	—	60	100	—	mA
ΔV _{OUT}	Load Regulation	5V	1mA ≤ I _{OUT} ≤ 50mA	—	60	150	mV
V _{DIF}	Voltage Drop	—	I _{OUT} =1mA	—	100	—	mV
I _{SS}	Current Consumption	5V	No load	—	3.5	7	μA
$\frac{\Delta V_{OUT}}{\Delta V_{IN} \times V_{OUT}}$	Line Regulation	—	4V ≤ V _{IN} ≤ 24V I _{OUT} =1mA	—	0.2	—	%/V
V _{IN}	Input Voltage	—	—	—	—	24	V
$\frac{\Delta V_{OUT}}{\Delta T_a}$	Temperature Coefficient	5V	I _{OUT} =10mA 0°C < Ta < 70°C	—	±0.45	—	mV/°C

HT7533-1, +3.3V output type

Ta=25°C

Symbol	Parameter	Test Conditions		Min.	Typ.	Max.	Unit
		V _{IN}	Conditions				
V _{OUT}	Output Voltage Tolerance	5.5V	I _{OUT} =10mA	3.201	3.3	3.399	V
I _{OUT}	Output Current	5.5V	—	60	100	—	mA
ΔV _{OUT}	Load Regulation	5.5V	1mA ≤ I _{OUT} ≤ 50mA	—	60	150	mV
V _{DIF}	Voltage Drop	—	I _{OUT} =1mA	—	100	—	mV
I _{SS}	Current Consumption	5.5V	No load	—	3.5	7	μA
$\frac{\Delta V_{OUT}}{\Delta V_{IN} \times V_{OUT}}$	Line Regulation	—	4.5V ≤ V _{IN} ≤ 24V I _{OUT} =1mA	—	0.2	—	%/V
V _{IN}	Input Voltage	—	—	—	—	24	V
$\frac{\Delta V_{OUT}}{\Delta T_a}$	Temperature Coefficient	5.5V	I _{OUT} =10mA 0°C < Ta < 70°C	—	±0.5	—	mV/°C

HT7536-1, +3.6V output type

Ta=25°C

Symbol	Parameter	Test Conditions		Min.	Typ.	Max.	Unit
		V _{IN}	Conditions				
V _{OUT}	Output Voltage Tolerance	5.6V	I _{OUT} =10mA	3.492	3.6	3.708	V
I _{OUT}	Output Current	5.6V	—	60	100	—	mA
ΔV _{OUT}	Load Regulation	5.6V	1mA ≤ I _{OUT} ≤ 50mA	—	60	150	mV
V _{DIF}	Voltage Drop	—	I _{OUT} =1mA	—	100	—	mV
I _{SS}	Current Consumption	5.6V	No load	—	3.5	7	μA
$\frac{\Delta V_{OUT}}{\Delta V_{IN} \times V_{OUT}}$	Line Regulation	—	4.6V ≤ V _{IN} ≤ 24V I _{OUT} =1mA	—	0.2	—	%/V
V _{IN}	Input Voltage	—	—	—	—	24	V
$\frac{\Delta V_{OUT}}{\Delta T_a}$	Temperature Coefficient	5.6V	I _{OUT} =10mA 0°C < Ta < 70°C	—	±0.6	—	mV/°C

HT7544-1, +4.4V output type

Ta=25°C

Symbol	Parameter	Test Conditions		Min.	Typ.	Max.	Unit
		V _{IN}	Conditions				
V _{OUT}	Output Voltage Tolerance	6.4V	I _{OUT} =10mA	4.268	4.4	4.532	V
I _{OUT}	Output Current	6.4V	—	60	100	—	mA
ΔV _{OUT}	Load Regulation	6.4V	1mA≤I _{OUT} ≤50mA	—	60	150	mV
V _{DIF}	Voltage Drop	—	I _{OUT} =1mA	—	100	—	mV
I _{SS}	Current Consumption	6.4V	No load	—	3.5	7	μA
$\frac{\Delta V_{OUT}}{\Delta V_{IN} \times V_{OUT}}$	Line Regulation	—	5.4V≤V _{IN} ≤24V I _{OUT} =1mA	—	0.2	—	%/V
V _{IN}	Input Voltage	—	—	—	—	24	V
$\frac{\Delta V_{OUT}}{\Delta T_a}$	Temperature Coefficient	6.4V	I _{OUT} =10mA 0°C<Ta<70°C	—	±0.7	—	mV/°C

HT7550-1, +5.0V output type

Ta=25°C

Symbol	Parameter	Test Conditions		Min.	Typ.	Max.	Unit
		V _{IN}	Conditions				
V _{OUT}	Output Voltage Tolerance	7V	I _{OUT} =10mA	4.85	5.0	5.15	V
I _{OUT}	Output Current	7V	—	100	150	—	mA
ΔV _{OUT}	Load Regulation	7V	1mA≤I _{OUT} ≤70mA	—	60	150	mV
V _{DIF}	Voltage Drop	—	I _{OUT} =1mA	—	100	—	mV
I _{SS}	Current Consumption	7V	No load	—	3.5	7	μA
$\frac{\Delta V_{OUT}}{\Delta V_{IN} \times V_{OUT}}$	Line Regulation	—	6V≤V _{IN} ≤24V I _{OUT} =1mA	—	0.2	—	%/V
V _{IN}	Input Voltage	—	—	—	—	24	V
$\frac{\Delta V_{OUT}}{\Delta T_a}$	Temperature Coefficient	7V	I _{OUT} =10mA 0°C<Ta<70°C	—	±0.75	—	mV/°C

Application Circuits

Basic circuit

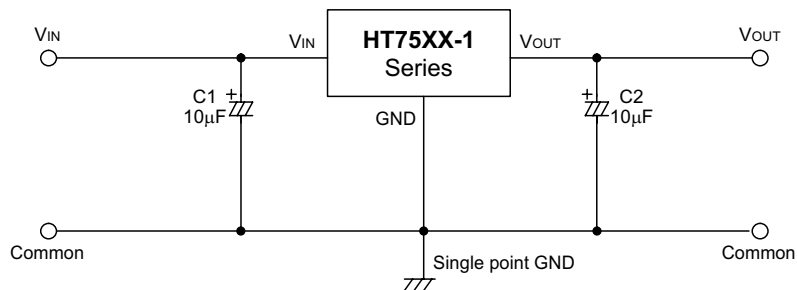

High output current positive voltage regulator

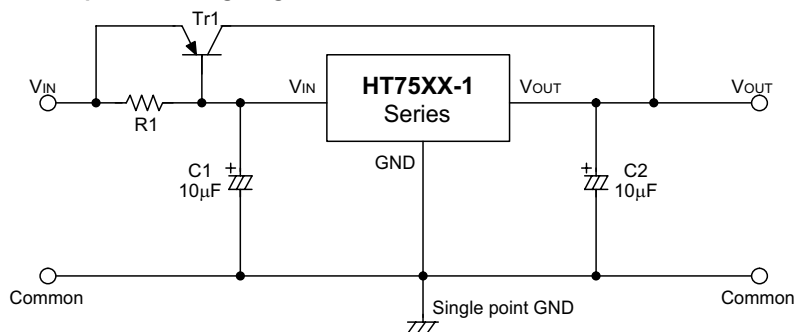

Short-Circuit protection for Tr1

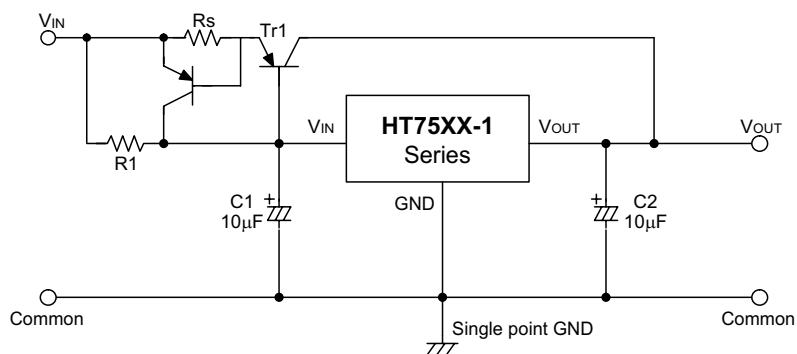

Circuit for increasing output voltage

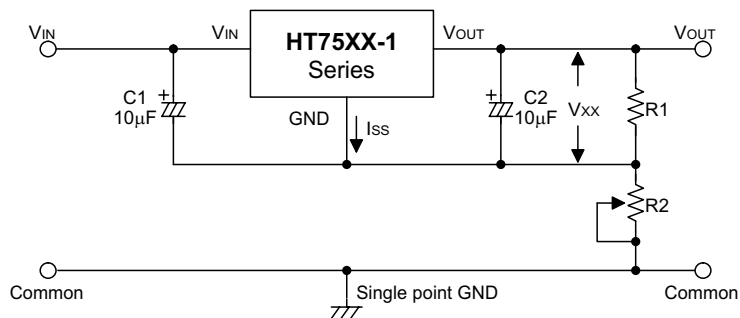

$$V_{OUT} = V_{xx} \left(1 + \frac{R2}{R1} \right) + I_{SS} R2$$

Circuit for increasing output voltage

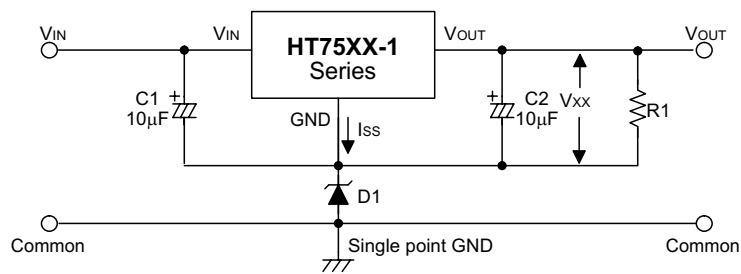

$$V_{OUT} = V_{XX} + V_{D1}$$

Constant current regulator

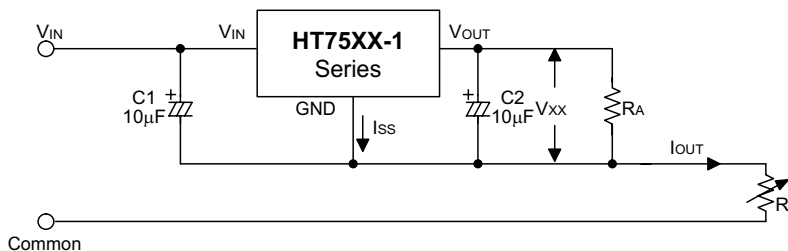

$$I_{OUT} = \frac{V_{XX}}{R_A} + I_{SS}$$

Dual supply

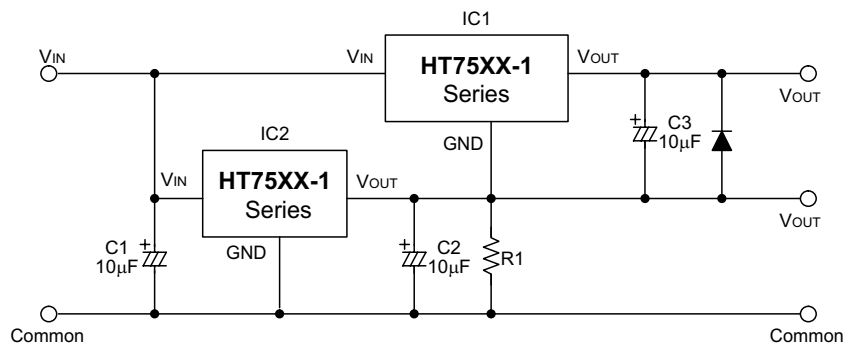

Package Information

3-pin TO-92 outline dimensions

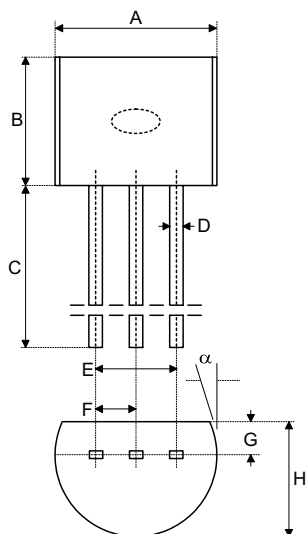

Symbol	Dimensions in mil		
	Min.	Nom.	Max.
A	170	—	200
B	170	—	200
C	500	—	—
D	11	—	20
E	90	—	110
F	45	—	55
G	45	—	65
H	130	—	160
I	8	—	18
α	4°	—	6°

3-pin SOT-89 outline dimensions

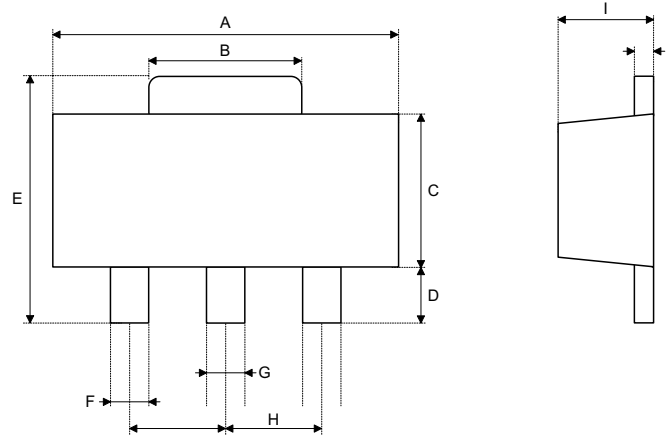

Symbol	Dimensions in mil		
	Min.	Nom.	Max.
A	173	—	181
B	64	—	72
C	90	—	102
D	35	—	47
E	155	—	167
F	14	—	19
G	17	—	22
H	—	59	—
I	55	—	63
J	14	—	17

5-pin SOT-25 outline dimensions

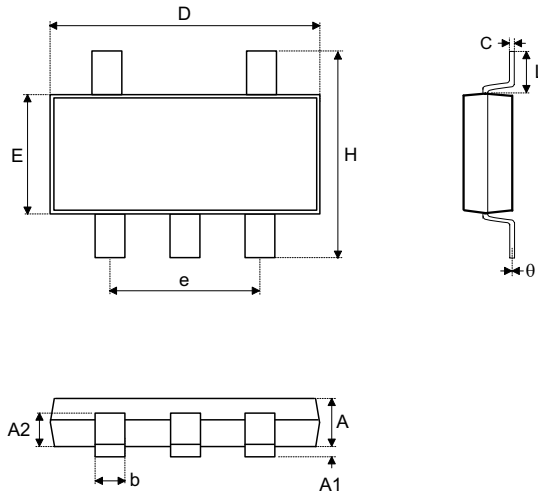

Symbol	Dimensions in mm		
	Min.	Nom.	Max.
A	1.00	—	1.30
A1	—	—	0.10
A2	0.70	—	0.90
b	0.35	—	0.50
C	0.10	—	0.25
D	2.70	—	3.10
E	1.40	—	1.80
e	—	1.90	—
H	2.60	—	3
L	0.37	—	—
θ	1°	—	9°

Product Tape and Reel Specifications

TO-92 reel dimensions (Unit: mm)

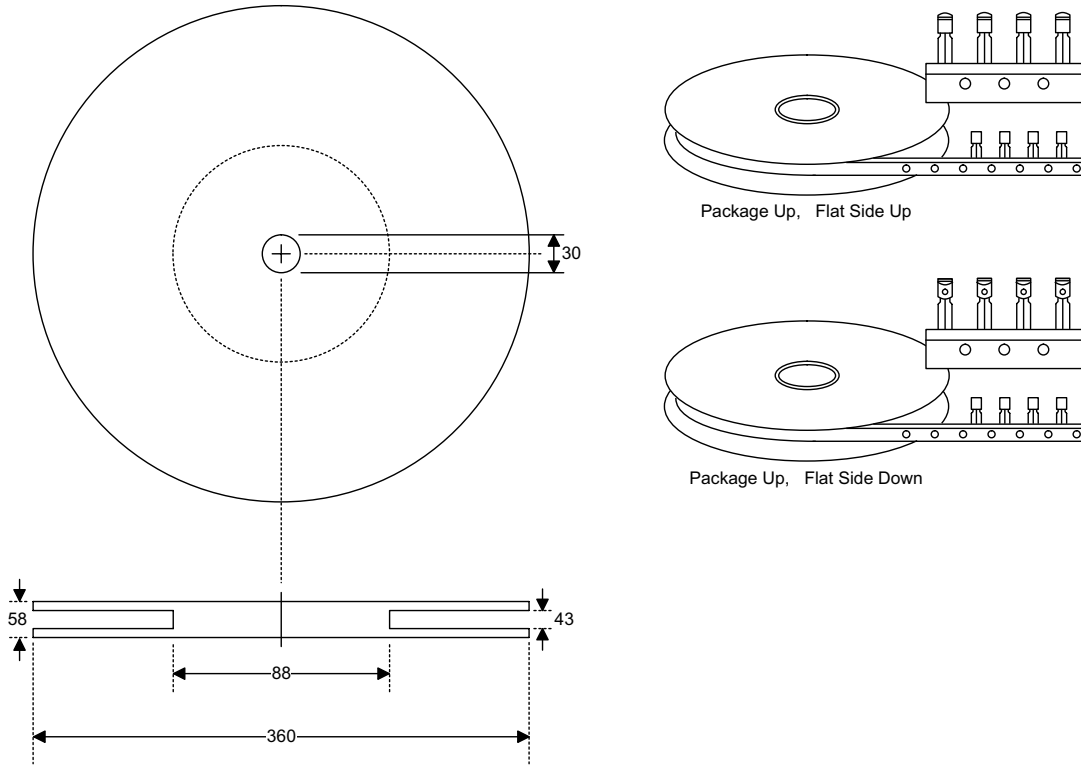

SOT-89 & SOT-25 reel dimensions

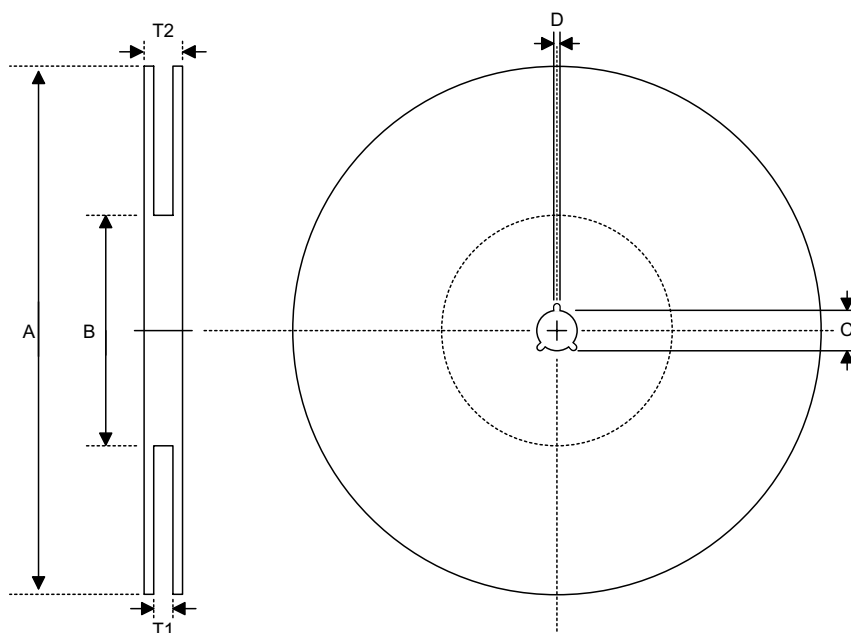

SOT-89

Symbol	Description	Dimensions in mm
A	Reel Outer Diameter	180±1.0
B	Reel Inner Diameter	62±1.5
C	Spindle Hole Diameter	12.75±0.15
D	Key Slit Width	1.9±0.15
T1	Space Between Flange	12.4±0.2
T2	Reel Thickness	17-0.4

SOT-25

Symbol	Description	Dimensions in mm
A	Reel Outer Diameter	178±1.0
B	Reel Inner Diameter	62±1.0
C	Spindle Hole Diameter	13.0±0.2
D	Key Slit Width	2.5±0.25
T1	Space Between Flange	8.4±1.5 -0.0
T2	Reel Thickness	11.4±1.5

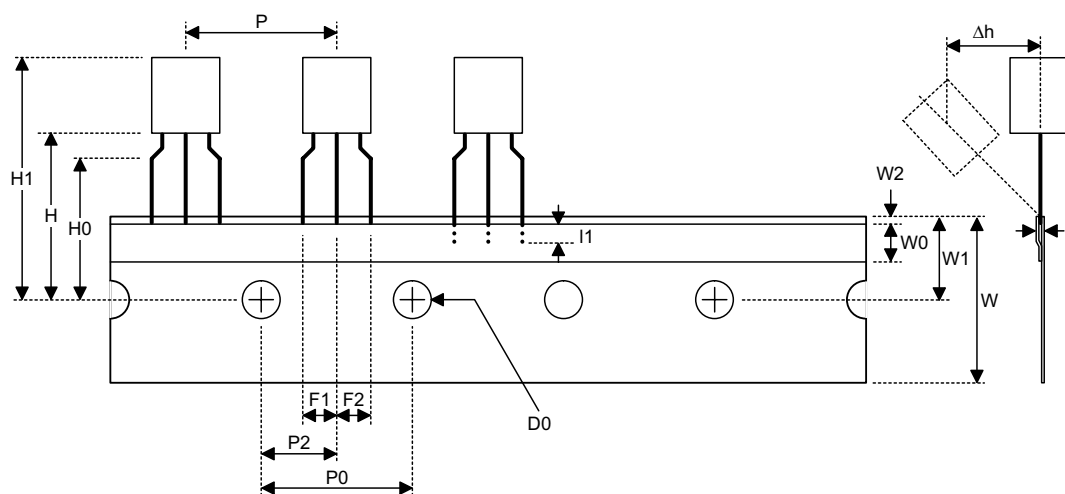
TO-92 carrier tape dimensions

TO-92

Symbol	Description	Dimensions in mm
l ₁	Taped Lead Length	(2.5)
P	Component Pitch	12.7±1.0
P ₀	Perforation Pitch	12.7±0.3
P ₂	Component to Perforation (Length Direction)	6.35±0.4
F ₁	Lead Spread	2.5+0.4 -0.1
F ₂	Lead Spread	2.5+0.4 -0.1
Δh	Component Alignment	0±0.1
W	Carrier Tape Width	18.0+1.0 -0.5
W ₀	Hold-down Tape Width	6.0±0.5
W ₁	Perforation Position	9.0±0.5
W ₂	Hold-down Tape Position	(0.5)
H ₀	Lead Clinch Height	16.0±0.5
H ₁	Component Height	Less than 24.7
D ₀	Perforation Diameter	4.0±0.2
t	Taped Lead Thickness	0.7±0.2
H	Component Base Height	19.0±0.5

Note: Thickness less than 0.38±0.05mm~0.5mm

P₀ Accumulated pitch tolerance: ±1mm/20pitches.

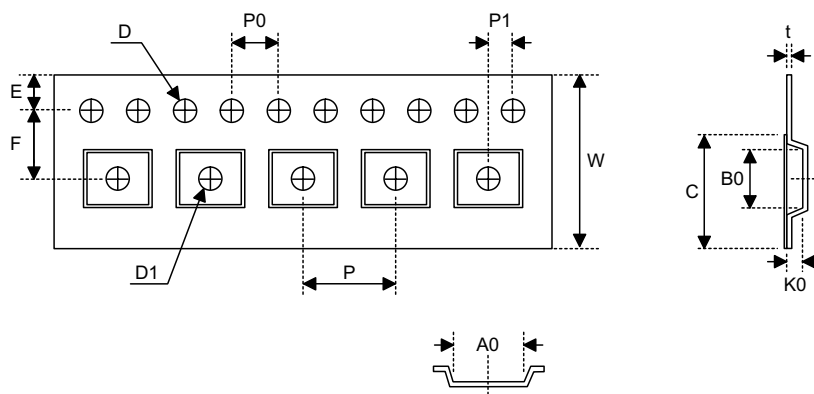
() Bracketed figures are for consultation only

SOT-89 & SOT-25 carrier tape dimensions

SOT-89

Symbol	Description	Dimensions in mm
W	Carrier Tape Width	12.0+0.3 -0.1
P	Cavity Pitch	8.0±0.1
E	Perforation Position	1.75±0.1
F	Cavity to Perforation (Width Direction)	5.5±0.05
D	Perforation Diameter	1.5+0.1
D1	Cavity Hole Diameter	1.5+0.1
P0	Perforation Pitch	4.0±0.1
P1	Cavity to Perforation (Length Direction)	2.0±0.10
A0	Cavity Length	4.8±0.1
B0	Cavity Width	4.5±0.1
K0	Cavity Depth	1.8±0.1
t	Carrier Tape Thickness	0.30±0.013
C	Cover Tape Width	9.3

SOT-25

Symbol	Description	Dimensions in mm
W	Carrier Tape Width	8.0±0.3
P	Cavity Pitch	4.0
E	Perforation Position	1.75
F	Cavity to Perforation (Width Direction)	3.5±0.05
D	Perforation Diameter	1.5+0.1
D1	Cavity Hole Diameter	1.5+0.1
P0	Perforation Pitch	4.0
P1	Cavity to Perforation (Length Direction)	2.0
A0	Cavity Length	3.15
B0	Cavity Width	3.2
K0	Cavity Depth	1.4
t	Carrier Tape Thickness	0.20±0.03
C	Cover Tape Width	5.3

Holtek Semiconductor Inc. (Headquarters)

No.3, Creation Rd. II, Science-based Industrial Park, Hsinchu, Taiwan
Tel: 886-3-563-1999
Fax: 886-3-563-1189
<http://www.holtek.com.tw>

Holtek Semiconductor Inc. (Sales Office)

11F, No.576, Sec.7 Chung Hsiao E. Rd., Taipei, Taiwan
Tel: 886-2-2782-9635
Fax: 886-2-2782-9636
Fax: 886-2-2782-7128 (International sales hotline)

Holtek Semiconductor (Shanghai) Inc.

7th Floor, Building 2, No.889, Yi Shan Rd., Shanghai, China
Tel: 021-6485-5560
Fax: 021-6485-0313
<http://www.holtek.com.cn>

Holtek Semiconductor (Hong Kong) Ltd.

Block A, 3/F, Tin On Industrial Building, 777-779 Cheung Sha Wan Rd., Kowloon, Hong Kong
Tel: 852-2-745-8288
Fax: 852-2-742-8657

Holmate Semiconductor, Inc.

46712 Fremont Blvd., Fremont, CA 94538
Tel: 510-252-9880
Fax: 510-252-9885
<http://www.holmate.com>

Copyright © 2002 by HOLTEK SEMICONDUCTOR INC.

The information appearing in this Data Sheet is believed to be accurate at the time of publication. However, Holtek assumes no responsibility arising from the use of the specifications described. The applications mentioned herein are used solely for the purpose of illustration and Holtek makes no warranty or representation that such applications will be suitable without further modification, nor recommends the use of its products for application that may present a risk to human life due to malfunction or otherwise. Holtek's products are not authorized for use as critical components in life support devices or systems. Holtek reserves the right to alter its products without prior notification. For the most up-to-date information, please visit our web site at <http://www.holtek.com.tw>.