

**FAIRCHILD**  
SEMICONDUCTOR™

September 1983  
Revised February 1999

## MM74HC374 3-STATE Octal D-Type Flip-Flop

### General Description

The MM74HC374 high speed Octal D-Type Flip-Flops utilize advanced silicon-gate CMOS technology. They possess the high noise immunity and low power consumption of standard CMOS integrated circuits, as well as the ability to drive 15 LS-TTL loads. Due to the large output drive capability and the 3-STATE feature, these devices are ideally suited for interfacing with bus lines in a bus organized system.

These devices are positive edge triggered flip-flops. Data at the D inputs, meeting the setup and hold time requirements, are transferred to the Q outputs on positive going transitions of the CLOCK (CK) input. When a high logic level is applied to the OUTPUT CONTROL (OC) input, all outputs go to a high impedance state, regardless of what

signals are present at the other inputs and the state of the storage elements.

The 74HC logic family is speed, function, and pinout compatible with the standard 74LS logic family. All inputs are protected from damage due to static discharge by internal diode clamps to  $V_{CC}$  and ground.

### Features

- Typical propagation delay: 20 ns
- Wide operating voltage range: 2–6V
- Low input current: 1  $\mu$ A maximum
- Low quiescent current: 80  $\mu$ A maximum
- Compatible with bus-oriented systems
- Output drive capability: 15 LS-TTL loads

### Ordering Code:

Order Number	Package Number	Package Description
MM74HC374WM	M20B	20-Lead Small Outline Integrated Circuit (SOIC), JEDEC MS-013, 0.300" Wide
MM74HC374SJ	M20D	20-Lead Small Outline Package (SOP), EIAJ TYPE II, 5.3mm Wide
MM74HC374MTC	MTC20	20-Lead Thin Shrink Small Outline Package (TSSOP), JEDEC MO-153, 4.4mm Wide
MM74HC374N	N20A	20-Lead Plastic Dual-In-Line Package (PDIP), JEDEC MS-001, 0.300" Wide

Devices also available in Tape and Reel. Specify by appending the suffix letter "X" to the ordering code.

### Connection Diagram

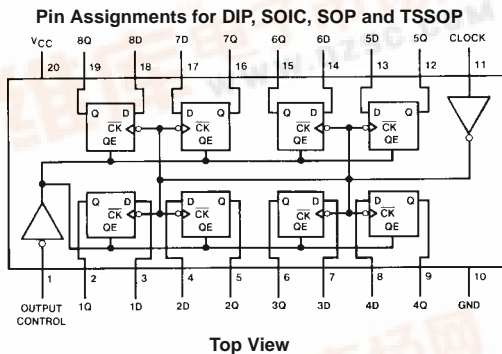

### Truth Table

Output Control	Clock	Data	Output
L	↑	H	H
L	↑	L	L
L	L	X	$Q_0$
H	X	X	Z

H = HIGH Level  
L = LOW Level  
X = Don't Care  
↑ = Transition from LOW-to-HIGH  
Z = High Impedance State  
 $Q_0$  = The level of the output before steady state input conditions were established

MM74HC374 3-STATE Octal D-Type Flip-Flop



**Absolute Maximum Ratings** (Note 1)

(Note 2)

Supply Voltage ( $V_{CC}$ )	-0.5 to +7.0V
DC Input Voltage ( $V_{IN}$ )	-1.5 to $V_{CC} + 1.5V$
DC Output Voltage ( $V_{OUT}$ )	-0.5 to $V_{CC} + 0.5V$
Clamp Diode Current ( $I_{IK}, I_{OK}$ )	$\pm 20$ mA
DC Output Current, per pin ( $I_{OUT}$ )	$\pm 35$ mA
DC $V_{CC}$ or GND Current, per pin ( $I_{CC}$ )	$\pm 70$ mA
Storage Temperature Range ( $T_{STG}$ )	-65°C to +150°C
Power Dissipation ( $P_D$ )	
(Note 3)	600 mW
S.O. Package only	500 mW
Lead Temperature ( $T_L$ )	
(Soldering 10 seconds)	260°C

**Recommended Operating Conditions**

	Min	Max	Units
Supply Voltage ( $V_{CC}$ )	2	6	V
DC Input or Output Voltage ( $V_{IN}, V_{OUT}$ )	0	$V_{CC}$	V
Operating Temperature Range ( $T_A$ )	-40	+85	°C
Input Rise or Fall Times ( $t_r, t_f$ )			
$V_{CC} = 2.0V$		1000	ns
$V_{CC} = 4.5V$		500	ns
$V_{CC} = 6.0V$		400	ns

**Note 1:** Absolute Maximum Ratings are those values beyond which damage to the device may occur.

**Note 2:** Unless otherwise specified all voltages are referenced to ground.

**Note 3:** Power Dissipation temperature derating — plastic "N" package: -12 mW/°C from 65°C to 85°C.

**DC Electrical Characteristics**

Symbol	Parameter	Conditions	$V_{CC}$	$T_A = 25^\circ\text{C}$			Units	
				Typ	Guaranteed Limits			
$V_{IH}$	Minimum HIGH Level Input Voltage		2.0V		1.5	1.5	V	
			4.5V		3.15	3.15	V	
			6.0V		4.2	4.2	V	
$V_{IL}$	Maximum LOW Level Input Voltage		2.0V		0.5	0.5	V	
			4.5V		1.35	1.35	V	
			6.0V		1.8	1.8	V	
$V_{OH}$	Minimum HIGH Level Output Voltage	$V_{IN} = V_{IH}$ or $V_{IL}$ $ I_{OUT}  \leq 20 \mu\text{A}$	2.0V	2.0	1.9	1.9	V	
			4.5V	4.5	4.4	4.4	V	
			6.0V	6.0	5.9	5.9	V	
		$V_{IN} = V_{IH}$ or $V_{IL}$ $ I_{OUT}  \leq 6.0 \text{ mA}$ $ I_{OUT}  \leq 7.8 \text{ mA}$	4.5V	4.2	3.98	3.84	3.7	V
			6.0V	5.7	5.48	5.34	5.2	V
$V_{OL}$	Maximum LOW Level Output Voltage	$V_{IN} = V_{IH}$ or $V_{IL}$ $ I_{OUT}  \leq 20 \mu\text{A}$	2.0V	0	0.1	0.1	V	
			4.5V	0	0.1	0.1	V	
			6.0V	0	0.1	0.1	V	
		$V_{IN} = V_{IH}$ or $V_{IL}$ $ I_{OUT}  \leq 6.0 \text{ mA}$ $ I_{OUT}  \leq 7.8 \text{ mA}$	4.5V	0.2	0.26	0.33	0.4	V
			6.0V	0.2	0.26	0.33	0.4	V
$I_{IN}$	Maximum Input Current	$V_{IN} = V_{CC}$ or GND	6.0V		$\pm 0.1$	$\pm 1.0$	$\pm 1.0$	$\mu\text{A}$
$I_{OZ}$	Maximum 3-STATE Output Leakage Current	$V_{IN} = V_{IH}$ , $OC = V_{IH}$ $V_{OUT} = V_{CC}$ or GND	6.0V		$\pm 0.5$	$\pm 5$	$\pm 10$	$\mu\text{A}$
$I_{CC}$	Maximum Quiescent Supply Current	$V_{IN} = V_{CC}$ or GND $I_{OUT} = 0 \mu\text{A}$	6.0V		8.0	80	160	$\mu\text{A}$

**Note 4:** For a power supply of  $5V \pm 10\%$  the worst case output voltages ( $V_{OH}$ , and  $V_{OL}$ ) occur for HC at 4.5V. Thus the 4.5V values should be used when designing with this supply. Worst case  $V_{IH}$  and  $V_{IL}$  occur at  $V_{CC} = 5.5V$  and 4.5V respectively. (The  $V_{IH}$  value at 5.5V is 3.85V.) The worst case leakage current ( $I_{IN}$ ,  $I_{CC}$ , and  $I_{OZ}$ ) occur for CMOS at the higher voltage and so the 6.0V values should be used.

**AC Electrical Characteristics** $V_{CC} = 5V, T_A = 25^{\circ}C, t_r = t_f = 6 \text{ ns}$ 

Symbol	Parameter	Conditions	Typ	Guaranteed Limit	Units
$f_{MAX}$	Maximum Operating Frequency		50	35	MHz
$t_{PHL}, t_{PLH}$	Maximum Propagation Delay Clock to Q	$C_L = 45 \text{ pF}$	20	32	ns
$t_{PZH}, t_{PZL}$	Maximum Output Enable Time	$R_L = k\Omega$ $C_L = 45 \text{ pF}$	19	28	ns
$t_{PHZ}, t_{PLZ}$	Maximum Output Disable Time	$R_L = k\Omega$ $C_L = 5 \text{ pF}$	17	25	ns
$t_S$	Minimum Setup Time			20	ns
$t_H$	Minimum Hold Time			5	ns
$t_W$	Minimum Pulse Width		9	16	ns

AC Electrical Characteristics								
V <sub>CC</sub> = 2.0–6.0V, C <sub>L</sub> = 50 pF, t <sub>r</sub> = t <sub>f</sub> = 6 ns (unless otherwise specified)								
Symbol	Parameter	Conditions	V <sub>CC</sub>	T <sub>A</sub> = 25°C	T <sub>A</sub> = –40 to 85°C	T <sub>A</sub> = –55 to 125°C	Units	
				Typ	Guaranteed Limits			
f <sub>MAX</sub>	Maximum Operating Frequency	C <sub>L</sub> = 50 pF	2.0V		6	5	4	MHz
			4.5V		30	24	20	MHz
			6.0V		35	28	23	MHz
t <sub>PHL</sub> , t <sub>PLH</sub>	Maximum Propagation Delay, Clock to Q	C <sub>L</sub> = 50 pF	2.0V	68	180	225	270	ns
		C <sub>L</sub> = 150 pF	2.0V	110	230	288	345	ns
		C <sub>L</sub> = 50 pF	4.5V	22	36	45	48	ns
		C <sub>L</sub> = 150 pF	4.5V	30	46	57	69	ns
		C <sub>L</sub> = 50 pF	6.0V	20	31	39	46	ns
t <sub>PZH</sub> , t <sub>PZL</sub>	Maximum Output Enable Time	R <sub>L</sub> = 1 kΩ						
		C <sub>L</sub> = 50 pF	2.0V	50	150	189	225	ns
		C <sub>L</sub> = 150 pF	2.0V	80	200	250	300	ns
		C <sub>L</sub> = 50 pF	4.5V	21	30	37	45	ns
		C <sub>L</sub> = 150 pF	4.5V	30	40	50	60	ns
t <sub>PHZ</sub> , t <sub>PLZ</sub>	Maximum Output Disable Time	R <sub>L</sub> = 1 kΩ	2.0V	50	150	189	225	ns
		C <sub>L</sub> = 50 pF	4.5V	21	30	37	45	ns
		C <sub>L</sub> = 150 pF	6.0V	19	26	31	39	ns
t <sub>S</sub>	Minimum Setup Time		2.0V		50	60	75	ns
			4.5V		9	13	15	ns
			6.0V		9	11	13	ns
t <sub>H</sub>	Minimum Hold Time		2.0V		5	30	5	ns
			4.5V		5	5	5	ns
			6.0V		5	5	5	ns
t <sub>W</sub>	Minimum Pulse Width		2.0V	30	80	100	120	ns
			4.5V	9	16	20	24	ns
			6.0V	8	14	18	20	ns
t <sub>THL</sub> , t <sub>TLH</sub>	Maximum Output Rise and Fall Time	C <sub>L</sub> = 50 pF	2.0V	25	60	75	90	ns
			4.5V	7	12	15	18	ns
			6.0V	6	10	13	15	ns
t <sub>r</sub> , t <sub>f</sub>	Maximum Input Rise and Fall Time, Clock		2.0V		1000	1000	1000	ns
			4.5V		500	500	500	ns
			6.0V		400	400	400	ns
C <sub>PD</sub>	Power Dissipation Capacitance (Note 5)	(per flip-flop)						
		OC = V <sub>CC</sub>		30				pF
		OC=GND		50				pF
C <sub>IN</sub>	Maximum Input Capacitance			5	10	10	10	pF

**Note 5:** C<sub>PD</sub> determines the no load dynamic power consumption, P<sub>D</sub> = C<sub>PD</sub> V<sub>CC</sub><sup>2</sup>f + I<sub>CC</sub> V<sub>CC</sub>, and the no load dynamic current consumption, I<sub>S</sub> = C<sub>PD</sub> V<sub>CC</sub> f + I<sub>CC</sub>.

**Physical Dimensions** inches (millimeters) unless otherwise noted

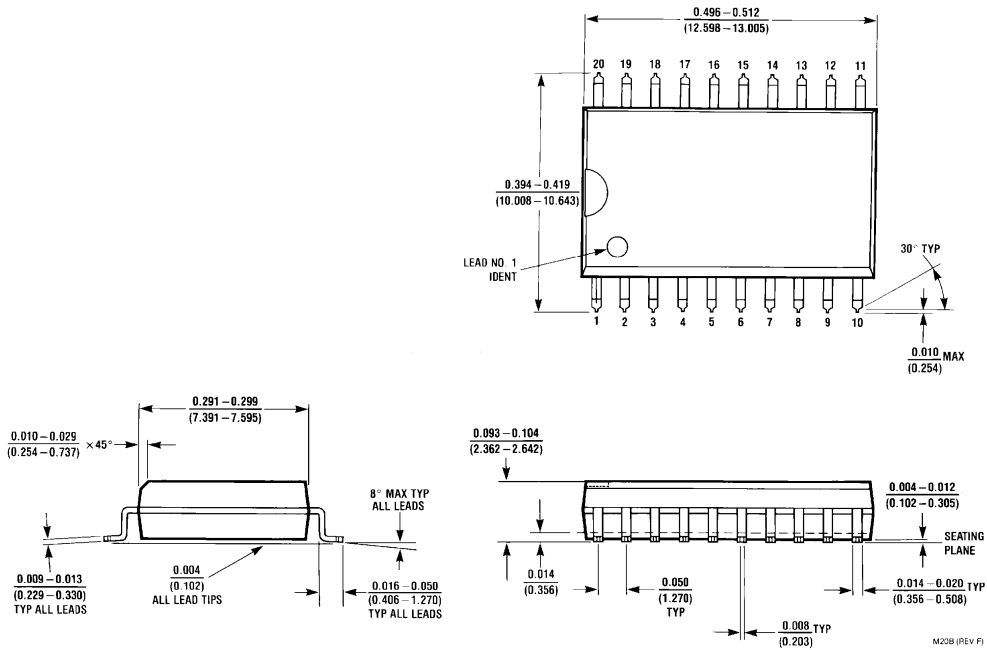

**20-Lead Small Outline Integrated Circuit (SOIC), JEDEC MS-013, 0.300" Wide  
Package Number M20B**

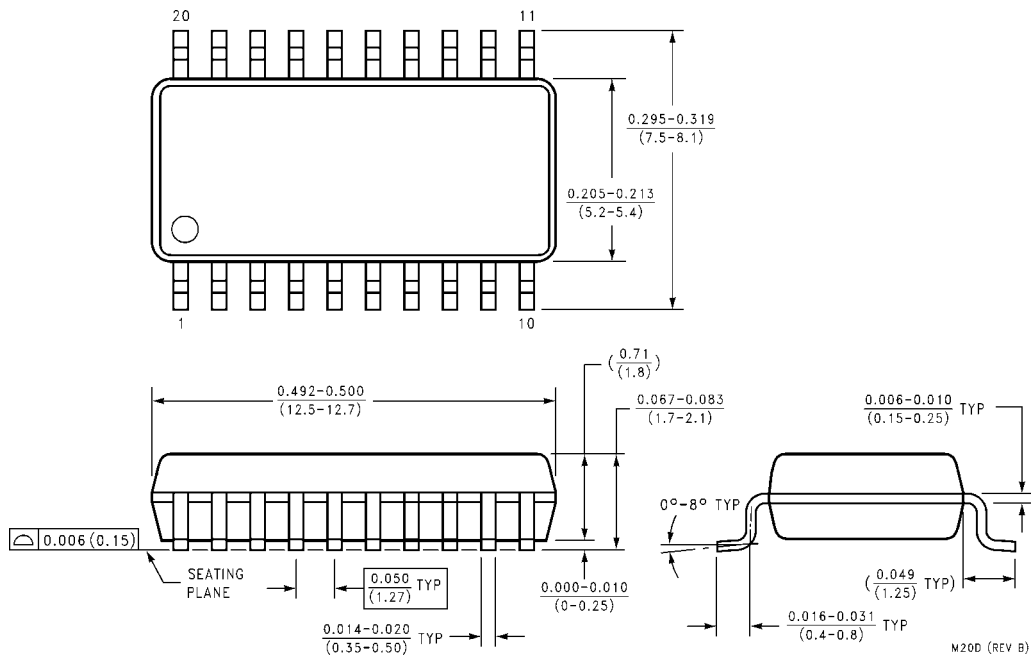

**20-Lead Small Outline Package (SOP), EIAJ TYPE II, 5.3mm Wide  
Package Number M20D**

**Physical Dimensions** inches (millimeters) unless otherwise noted (Continued)

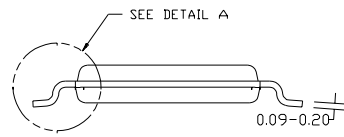
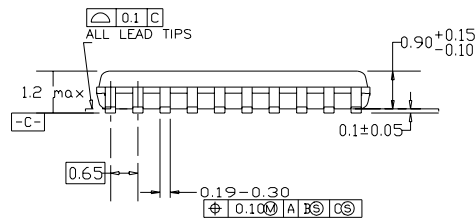
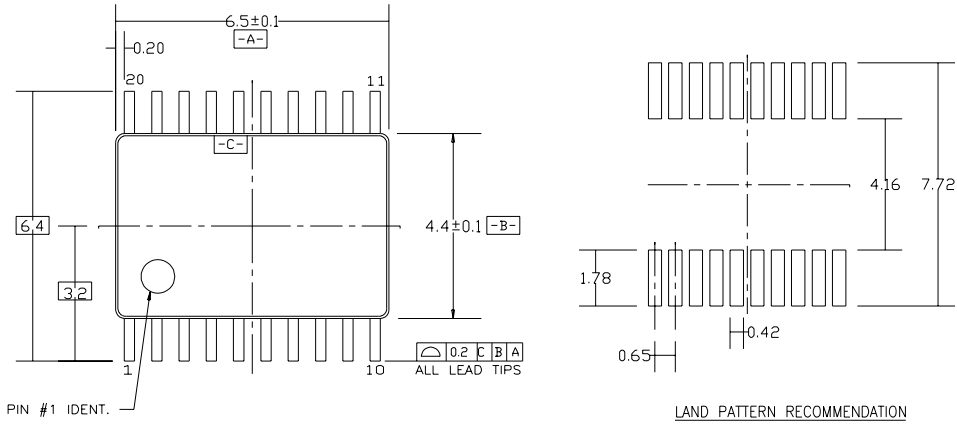

DIMENSIONS ARE IN MILLIMETERS

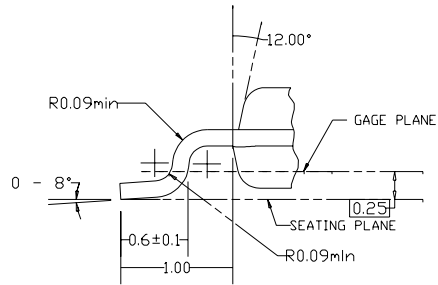

DETAIL A

NOTES:

- A. CONFORMS TO JEDEC REGISTRATION MO-153, VARIATION AC, REF NOTE 6, DATE 7/93.
- B. DIMENSIONS ARE IN MILLIMETERS.
- C. DIMENSIONS ARE EXCLUSIVE OF BURRS, MOLDS FLASH, AND TIE BAR EXTRUSIONS.
- D. DIMENSIONS AND TOLERANCES PER ANSI Y14.5M, 1982.

**20-Lead Thin Shrink Small Outline Package (TSSOP), JEDEC MO-153, 4.4mm Wide  
Package Number MTC20**

**Physical Dimensions** inches (millimeters) unless otherwise noted (Continued)

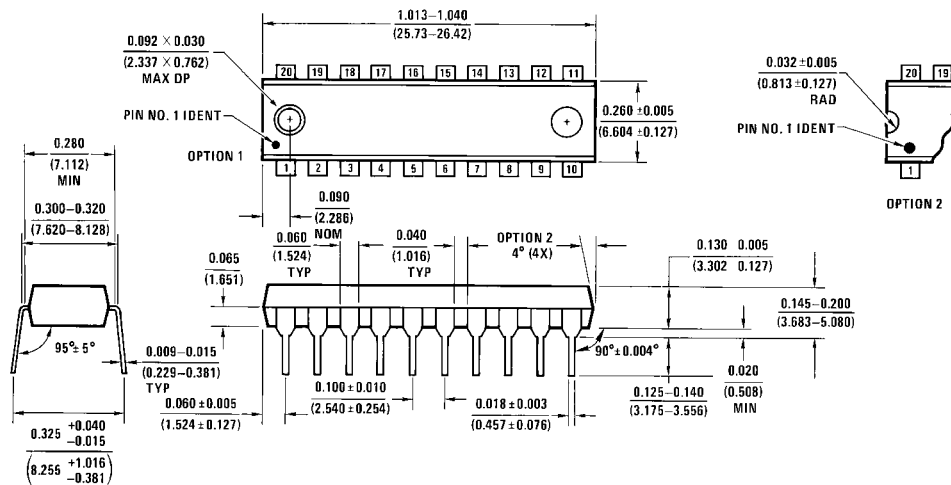

**20-Lead Plastic Dual-In-Line Package (PDIP), JEDEC MS-001, 0.300" Wide  
Package Number N20A**

N20A (REV G)

**LIFE SUPPORT POLICY**

FAIRCHILD'S PRODUCTS ARE NOT AUTHORIZED FOR USE AS CRITICAL COMPONENTS IN LIFE SUPPORT DEVICES OR SYSTEMS WITHOUT THE EXPRESS WRITTEN APPROVAL OF THE PRESIDENT OF FAIRCHILD SEMICONDUCTOR CORPORATION. As used herein:

1. Life support devices or systems are devices or systems which, (a) are intended for surgical implant into the body, or (b) support or sustain life, and (c) whose failure to perform when properly used in accordance with instructions for use provided in the labeling, can be reasonably expected to result in a significant injury to the user.
2. A critical component in any component of a life support device or system whose failure to perform can be reasonably expected to cause the failure of the life support device or system, or to affect its safety or effectiveness.

[www.fairchildsemi.com](http://www.fairchildsemi.com)