



# TDA7427A

## AM-FM RADIO FREQUENCY SYNTHESIZER AND IF COUNTER

- ON-CHIP REFERENCE OSCILLATOR AND PROGRAMMABLE IF COUNTER
- VHF INPUT AND PRECOUNTER FOR FREQUENCIES UP TO 290MHz (SUITABLE FOR DAB APPLICATION)
- HF INPUT FOR FREQUENCIES UP TO 64MHz (SHORT WAVE BAND)
- IN-LOCK DETECTOR FOR SEARCH/STOP STATION FUNCTION
- STAND-BY MODE FOR LOW POWER CONSUMPTION
- HIGH CURRENT SOURCE FOR 0.5ms LOCK-IN TIME
- DIGITAL PORT EXTENSION WITH SIX OUTPUTS FOR FLEXIBILITY IN APPLICATION
- FULLY PROGRAMMABLE BY I<sup>2</sup>C BUS



with an additional IF counting system that performs all the functions needed in a complete PLL radio tuning system for conventional and high speed RDS tuners. The device has dedicated outputs for IN-LOCK detection and Search/Stop station.

### DESCRIPTION

The TDA7427A is a PLL frequency synthesizer

### BLOCK DIAGRAM

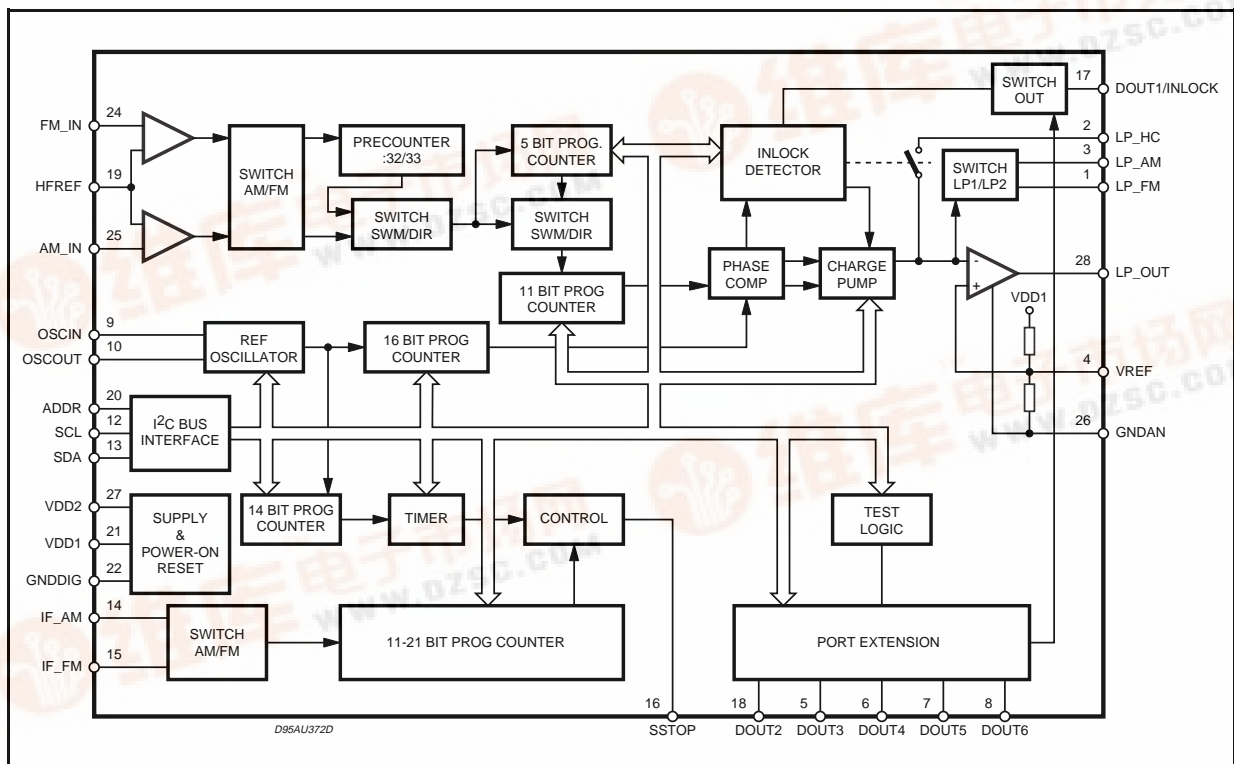

## TDA7427A

### ABSOLUTE MAXIMUM RATINGS

Symbol	Parameter	Value	Unit
V <sub>DD1</sub>	Supply Voltage	- 0.3 to + 7	V
V <sub>DD2</sub>	Supply Voltage	- 0.3 to + 11	V
P <sub>tot</sub>	Total Power Dissipation	300	mW
T <sub>stg</sub>	Storage Temperature	- 55 to + 150	°C
T <sub>amb</sub>	Ambient Temperature	-40 to + 85	°C

### PIN CONNECTION

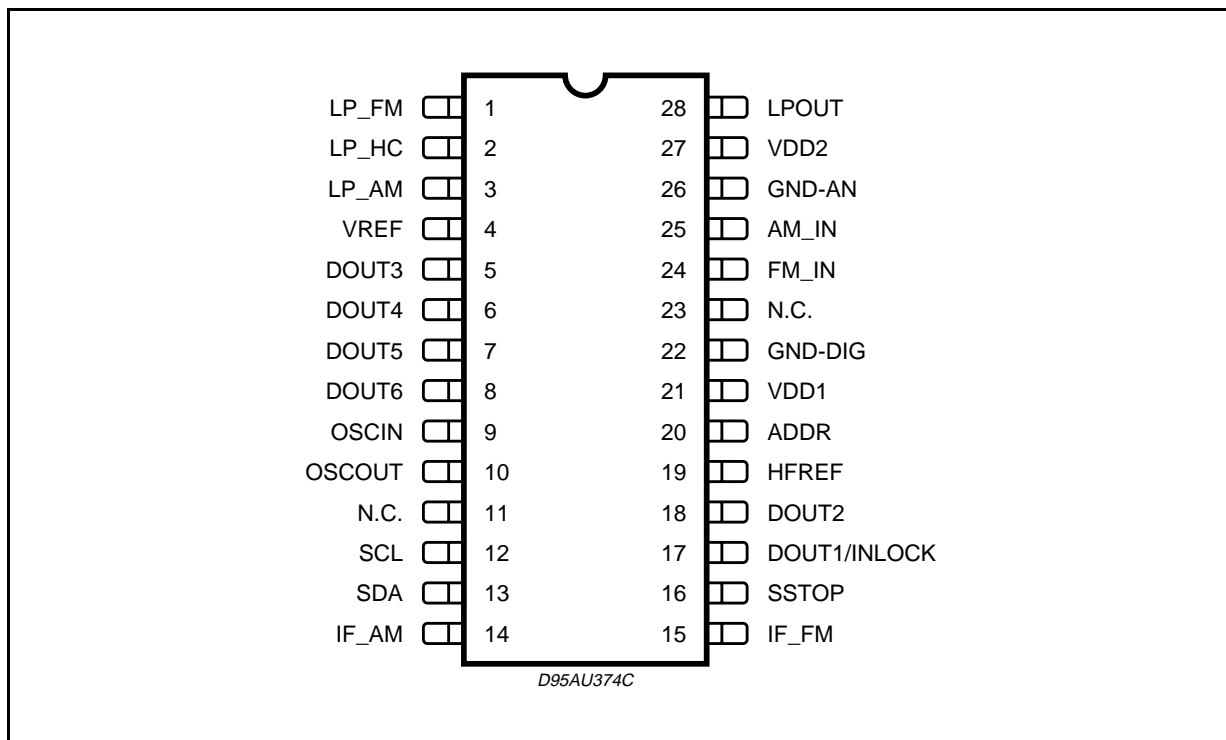

### THERMAL DATA

Symbol	Parameter	TSSOP28	SO 28	Unit
R <sub>th j-amb</sub>	Thermal Resistance Junction-Ambient	160	65	°C/W

## PIN DESCRIPTION

PIN	SYMBOL	DESCRIPTION
1	LP_FM	Filter OPAMP input, charge pump output (FM mode)
2	LP_HC	Filter OPAMP input, charge pump output (high current mode)
3	LP_AM	Filter OPAMP input, charge pump output (AM mode)
4	VREF	OPAMP reference voltage
5	DOUT3	Digital Output 3 (open collector)
6	DOUT4	Digital Output 4 (open collector)
7	DOUT5	Digital Output 5 (open collector)
8	DOUT6	Digital Output 6 (open collector)
9	OSCIN	Reference Oscillator Input
10	OSCOU	Reference Oscillator Output
11	N.C.	Not connected
12	SCL	I <sup>2</sup> C bus clock input
13	SDA	I <sup>2</sup> C bus data I/O
14	IF_AM	IF counter HF input
15	IF_FM	IF counter VHF input
16	SSTOP	IF counter result output
17*	DOUT1	Digital output 1 (push-pull)
17*	INLOCK	Inlock detector output
18	DOUT2	Digital Output 2 (open collector)
19	HF-REF	HF reference pin
20	ADDR	I <sup>2</sup> C bus address pin
21	VDD1	Supply Voltage
22	GND-DIG	Digital ground
23	N.C.	Not connected
24	FM_IN	High frequency input FM
25	AM_IN	High frequency input AM
26	GND-AN	Analog ground
27	VDD2	Supply Voltage
28	LP_OUT	Filter OPAMP output

\* Pin function is selectable by software (see software specification)

## TDA7427A

**ELECTRICAL CHARACTERISTICS** ( $T_{amb} = 25^{\circ}\text{C}$ ;  $V_{DD1} = 5\text{V}$ ;  $V_{DD2} = 10\text{V}$ ;  $f_{osc} = 4\text{MHz}$ ; unless otherwise specified).

Symbol	Parameter	Test Condition	Min.	Typ.	Max.	Unit
$V_{DD1}$	Supply Voltage		4.5	5.0	5.5	V
$V_{DD2}$	Supply Voltage			9.0	11.0	V
$I_{DD1}$	Supply Current	no output load	2	4	6	mA
$I_{DD2}$	Supply Current	PLL locked	1	2	3	mA
$I_{DD1\ STB}$	Supply Current	Standby mode			1	$\mu\text{A}$
<b>RF INPUT (AM_IN, FM_IN)</b>						
$f_{iAM}$	Input Frequency AM	$V_i = 100\text{mV}_{rms}$ sinusoidal	0.5		64	MHz
$f_{iFM}$	Input Frequency FM	$V_i = 100\text{mV}_{rms}$ sinusoidal	30		200	MHz
$V_{iMIN}$	Min Input Voltage AM	0.5 to 16MHz range sinusoidal			30	mVrms
$V_{iMAX}$	Max Input Voltage AM	0.6 to 16MHz range sinusoidal	600			mVrms
$V_{iMIN}$	Min Input Voltage FM	70 to 120MHz range sinusoidal			30	mVrms
$V_{iMAX}$	Max Input Voltage FM	70 to 120MHz range sinusoidal	600			mVrms
$Z_{in}$	Input Impedance FM input		3	4	5	$\text{K}\Omega$
$Z_{in}$	Input Impedance AM input		3	4	5	$\text{K}\Omega$
<b>IF COUNTER (IF_AM, IF_FM)</b>						
$f_{iAM}$	Input Frequency range AM	$V_i = 100\text{mV}_{rms}$	0.400		11	MHz
$f_{iFM}$	Input Frequency range FM	$V_i = 100\text{mV}_{rms}$	10		11	MHz
$V_{iMIN}$	Min Input Voltage AM IF pin	$f_{in} = 455\text{kHz}$			30	mVrms
$V_{iMIN}$	Min Input Voltage FM IF pin	$f_{in} = 10.7\text{MHz}$			30	mVrms
$V_{iMAX}$	Max Input Voltage AM IF pin	$f_{in} = 455\text{kHz}$	600			mVrms
$V_{iMAX}$	Max Input Voltage FM IF pin	$f_{in} = 10.7\text{MHz}$	600			mVrms
$Z_{in}$	Input Impedance FM IF pin		3	4	5	$\text{K}\Omega$
$Z_{in}$	Input Impedance AM IF pin		3	4	5	$\text{K}\Omega$
<b>BUS INTERFACE</b>						
$T_j$	Noise Suppression Time Constant on SCL, SDA Input			50		ns
$f_{SCL}$	SCL Clock Frequency				400	kHz
$t_{AA}$	SCL Low to SDA Data Valid		300			ns
$t_{buf}$	Time the bus must be free for the new transmission		4.7			$\mu\text{s}$
$t_{HD-START}$	START Condition hold time		4.0			$\mu\text{s}$
$t_{LOW}$	Clock Low Period		4.7			$\mu\text{s}$
$t_{HIGH}$	Clock High Period		4.0			$\mu\text{s}$
$t_{SU-SDA}$	Start Condition Setup Time		4.7			$\mu\text{s}$
$t_{HD-DATA}$	Data Input Hold Time				1	$\mu\text{s}$
$t_{SU-DATA}$	Data Input Setup Time		250			ns
$t_R$	SDA & SCL Rise Time				1	$\mu\text{s}$
$t_F$	SDA & SCL Full Time			0.3		$\mu\text{s}$
$t_{SU-STOP}$	Stop Condition Setup Time		4.7			$\mu\text{s}$
$t_{DH}$	DATA OUT Time		300			ns

## ELECTRICAL CHARACTERISTICS (continued)

Symbol	Parameter	Test Condition	Min.	Typ.	Max.	Unit
V <sub>IL</sub>	Input Low Voltage				1	V
V <sub>IH</sub>	Input High Voltage		3			V
I <sub>IN</sub>	Input Current		-5		+5	μA
V <sub>OUT</sub>	Output Voltage SDA acknowledge	I <sub>O</sub> = 1.6mA		0.15	0.4	V
<b>OSCILLATOR</b>						
t <sub>bu</sub>	Build Up Time	f <sub>out</sub> = 4MHz			100	ms
C <sub>in</sub>	Internal Capacitance			20		pF
C <sub>OUT</sub>	Internal Capacitance	f <sub>osc</sub> = 4MHz		20		pF
Z <sub>in</sub>	Input Impedance	f <sub>osc</sub> = 4MHz			100	KΩ
V <sub>in</sub>	Input Voltage (for Slave Mode)	f <sub>IN</sub> = 4 to 13MHz (Sinus) capacitance coupling	300		V <sub>DD</sub>	mV <sub>pp</sub>
f <sub>in</sub>	Max Input frequency (for Slave Mode)	V <sub>IN</sub> = 600mV <sub>PP</sub> (Sinus)	30			MHz
<b>LOOP FILTER (LP_FM, LP_AM, LP_HC, LP_OUT)</b>						
I <sub>IN</sub>	Input Leakage Current (*)	V <sub>IN</sub> = GND; PD <sub>out</sub> = Tristate (1)	-1	0.1	1	μA
I <sub>IN</sub>	Input Leakage Current (*)	V <sub>IN</sub> = V <sub>DD1</sub> ; PD <sub>out</sub> = Tristate (1)	-1	0.1	1	μA
V <sub>OL</sub>	Output Voltage Low	I <sub>IN</sub> = -0.2mA		0	0.5	V
V <sub>OH</sub>	Output Voltage High	I <sub>OUT</sub> = 0.2mA	9.5	10		V
I <sub>OUT</sub>	Output Current Sink		10	30		mA
I <sub>OUT</sub>	Output Current Source	V <sub>out</sub> = 0.5 to 9.5V	10	30		mA
<b>DOUT1/SSTOP (push-pull outputs)</b>						
V <sub>OL</sub>	Output Voltage Low	I <sub>OUT</sub> = -0.1mA		0.1	0.2	V
V <sub>OH</sub>	Output Voltage High	I <sub>OUT</sub> = 0.1mA	V <sub>DD1</sub> *0.2	4.9		V
<b>DOUT2 to 6 (open collector outputs)</b>						
I <sub>OUT</sub>	Output leakage Current	V <sub>OUT</sub> = 10V	-1	0.1	1	mA
V <sub>OL</sub>	Output Voltage Low	I <sub>OUT</sub> = -1mA		0.2	0.5	V
I <sub>OUT</sub>	Output Current Sink	V <sub>out</sub> = 0.5 to 9.5V		3	5	mA

1) PD = Phase Detector

(\*) LP\_FM and LP\_HC pins only

**GENERAL DESCRIPTION**

This circuit contains a frequency synthesiser and a loop filter for use in FM/AM radio tuning systems. Only a VCO is required to build a complete PLL system. For auto search/stop operation an IF counter system is available.

For FM and SW AM application, the counter works in a two-stage configuration. The first stage is a swallow counter with a two modulus (:32/33) precounter. The second stage is an 11-bit programmable counter.

For LW and MW application, a 16-bit programmable counter is available.

The circuit receives the scaling factors for the programmable counters and the values of the reference frequencies via a I<sup>2</sup>C bus interface.

The reference frequency is generated by an internal XTAL oscillator followed by the reference divider. The device can operate with XTAL oscillator between 4 and 13MHz either in master mode and in slave mode.

The reference and step frequencies are free selectable. (XTAL frequency divided by an integer value). The outputs signals of the phase detector are switching the programmable current sources. The loop filter integrates their currents to a DC voltage.

Values of the current sources are programmable by 6 bits also received via the I<sup>2</sup>C bus.

To minimize the noise induced by the digital part of the system, a separate power supply supplies the internal loop filter amplifier. The loop gain can be set for different conditions by setting the current values of the charge/pump generator.

**IF COUNTER SYSTEM**

Two separate inputs are available for AM and FM IF signals. The level of integration is adjustable by six different measuring cycle times.

The tolerance of the accepted count value is adjustable, to reach an optimum compromise for search speed and precision of the evaluation.

For the FM range the center frequency of the measured count value is adjustable in 32 steps, to get the possibility of fitting the IF filter tolerance. In the AM range an IF frequency of 448 to 479KHz ( 10.684 to 10.715MHz for AM up-conversion) with 1KHz steps is available.

**PLL FREQUENCY SYNTHESIZER**

**Input Amplifiers**

The signals applied on AM and FM inputs are amplified to get a logic level in order to drive the frequency dividers.

The typical input impedance for FM and AM inputs is 4kΩ.

**Table 1. Address Organization**

FUNCTION	SUBAD	MSB							LSB	
		BIT 7	BIT 6	BIT 5	BIT 4	BIT 3	BIT 2	BIT 1	BIT 0	
PLL CHARGE PUMP	00H	LPIN1/2	CURRH	B1	B0	A3	A2	A1	A0	
PLL COUNTER	01H	PC7	PC6	PC5	PC4	PC3	PC2	PC1	PC0	
PLL COUNTER	02H	PC15	PC14	PC13	PC12	PC11	PC10	PC9	PC8	
PLL REF COUNTER	03H	RC7	RC6	RC5	RC4	RC3	RC2	RC1	RC0	
PLL REF COUNTER	04H	RC15	RC14	RC13	RC12	RC11	RC10	RC9	RC8	
PLL LOCK DETECT	05H	LDENA	INLOCK	D3	D2	D1	D0	PM1	PM0	
IFC REF COUNTER	06H	IRC7	IRC6	IRC5	IRC4	IRC3	IRC2	IRC1	IRC0	
IFC REF COUNTER	07H	IFCM1	IFCM0	IRC13	IRC12	IRC11	IRC10	IRC9	IRC8	
IFC CONTROL	08H	IFENA	-	-	-	-	EW2	EW1	EW0	
IFC CONTROL	09H	IFS2	IFS1	IFS0	CF4	CF3	CF2	CF1	CF0	
OSC ADJUST	0AH	-	-	-	OSC4	OSC3	OSC2	OSC1	OSC0	
PORT EXTENSION	0BH	-	-	DOUT3	DOUT4	DOUT5	DOUT6	DOUT2	DOUT1	

Figure 1. FM and AM (SW) operation (swallow mode)

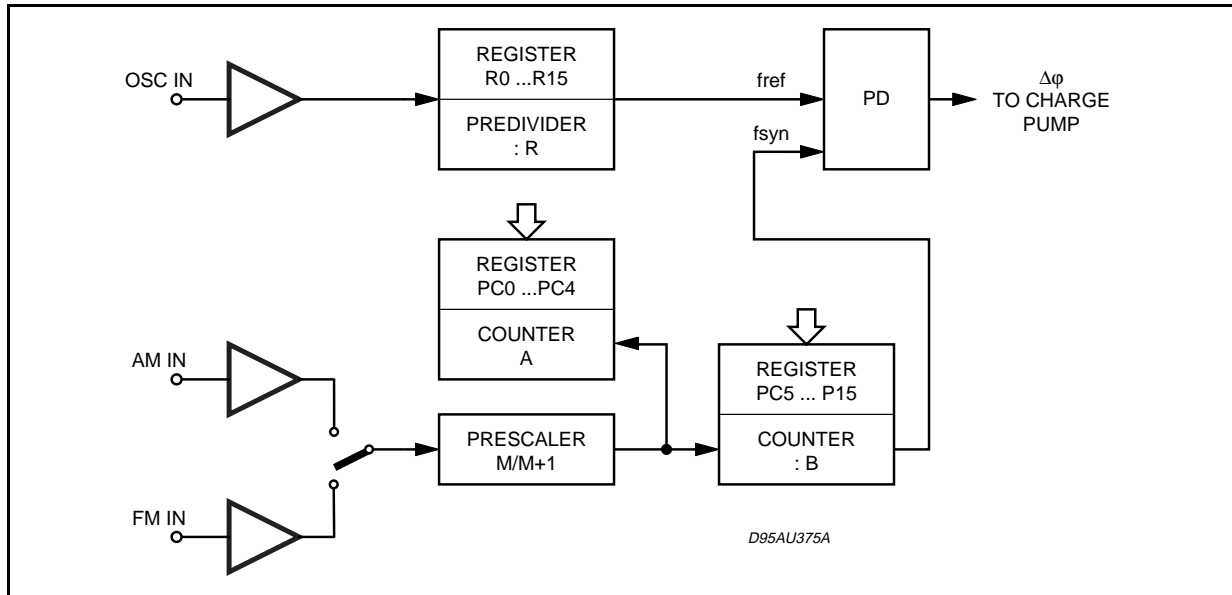
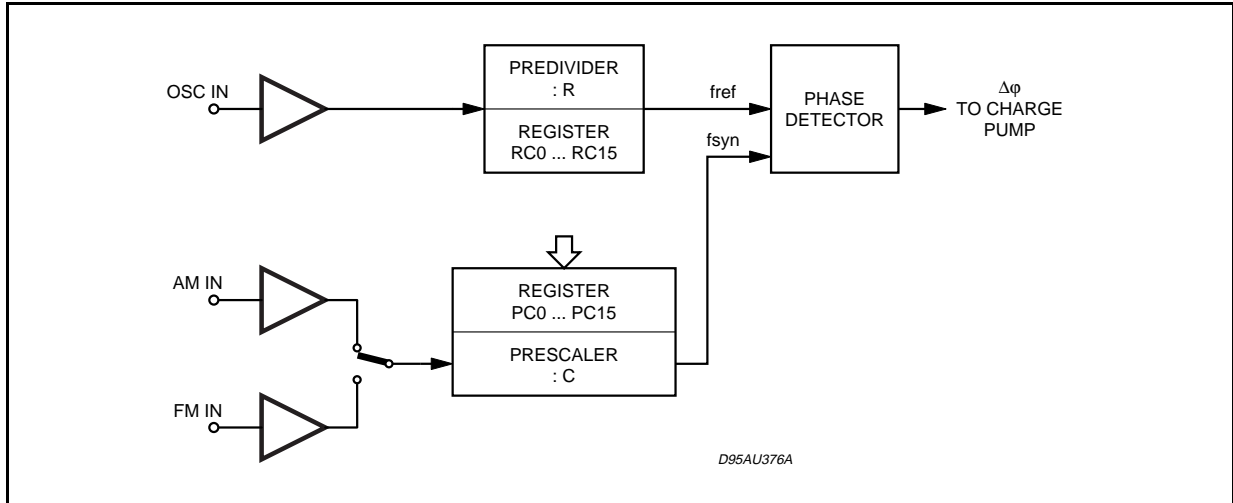

Table 2. Control Register Functions.

REGISTER NAME	FUNCTION
PC	Programmable counter for VCO frequency
RC	Reference counter PLL
IRC	Reference counter IF
IFCM	IF counter mode selector
EW	Frequency error window IF counter
IFENA	Enable IFRC
CF	Center frequency IF counter
IFS	Sampling time IF counter
PM	Stby, FM, AM, AM swallow mode selector
D	Programmable delay and phase error for lock detector
LPIN1/2	Loop filter input select
PLLSTOP	PLL stop
A	Charge pump high current
B	Charge pump low current
LDENA	Lock detector enable
CURRH	Set current high
OSC	Oscillator adjust
DOUT1	Push pull output 5V
DOUT2...6	Open collector output
INLOCK	Lock detector output

Figure 2. AM direct mode operation for SW, MW and LW



**DIVIDER FROM VCO FREQUENCY TO REFERENCE FREQUENCY**

This divider provides a low frequency  $f_{SYN}$  which phase is compared with the reference frequency  $f_{REF}$ . It is controlled by the registers PC0 to PC4 and PC5 to PC15

**OPERATING MODES**

Four operating modes are available for PLL; they are user programmable with the Mode PM registers (see table below).

PM0	PM1	Operating Mode
0	0	Standby
1	0	AM (swallow)
0	1	AM (direct)
1	1	FM

- **Standby mode:** in this mode all device functions are stopped. This allows low current consumption without loss of information in all registers. The pin LP-OUT is forced to 0V, and all data registers are set to EFH. The oscillator keeps running.

- **FM and AM (SW) Swallow Mode (SW):** in this mode the FM or AM signal is applied to a 32/33 prescaler, which is controlled by a 5 bit divider 'A'. The 5 bit register (PC0 to PC4) controls this divider. In parallel the output of the prescaler is connected to a 11 bit divider 'B'. (PC5 to PC15).

$$f_{OSC} = (R+1) \cdot f_{REF}$$

Dividing range calculation :

$$f_{VCO} = [ 33 \cdot A + (B + 1 - A) \cdot 32 ] \cdot f_{REF}$$

$$f_{VCO} = (32 \cdot B + A + 32) \cdot f_{REF}$$

Important: for correct operation  $A \leq 32$ ,  $B \geq A$ , with A and B variable values of the dividers).

- **AM direct mode:** the AM signal is applied directly to the 16 bit static divider 'C'. (PC0 to PC15)

$$f_{OSC} = (R + 1) \cdot f_{REF}$$

Dividing range:

$$f_{VCO} = (C + 1) \cdot f_{REF}$$

**THREE STATE PHASE COMPARATOR**

The phase comparator generates a phase error signal according to phase difference between  $f_{SYN}$  and  $f_{REF}$ . This phase error signal drives the charge pump current generator (fig. 3)

**CHARGE PUMP CURRENT GENERATOR**

This stage generates signed pulses of current. The phase error signal decides the duration and polarity of those pulses.

The current absolute values are programmable by A0, A1, A2 registers for high current and B0, B1, registers for low current.

**LOW NOISE CMOS OP-AMP**

An internal voltage divider at pin VREF connects the positive input of the low noise Op-Amp. The charge pump output connects the negative input. This internal amplifier in cooperation with external components can provide an active filter.



Figure 3. Phase comparator waveforms

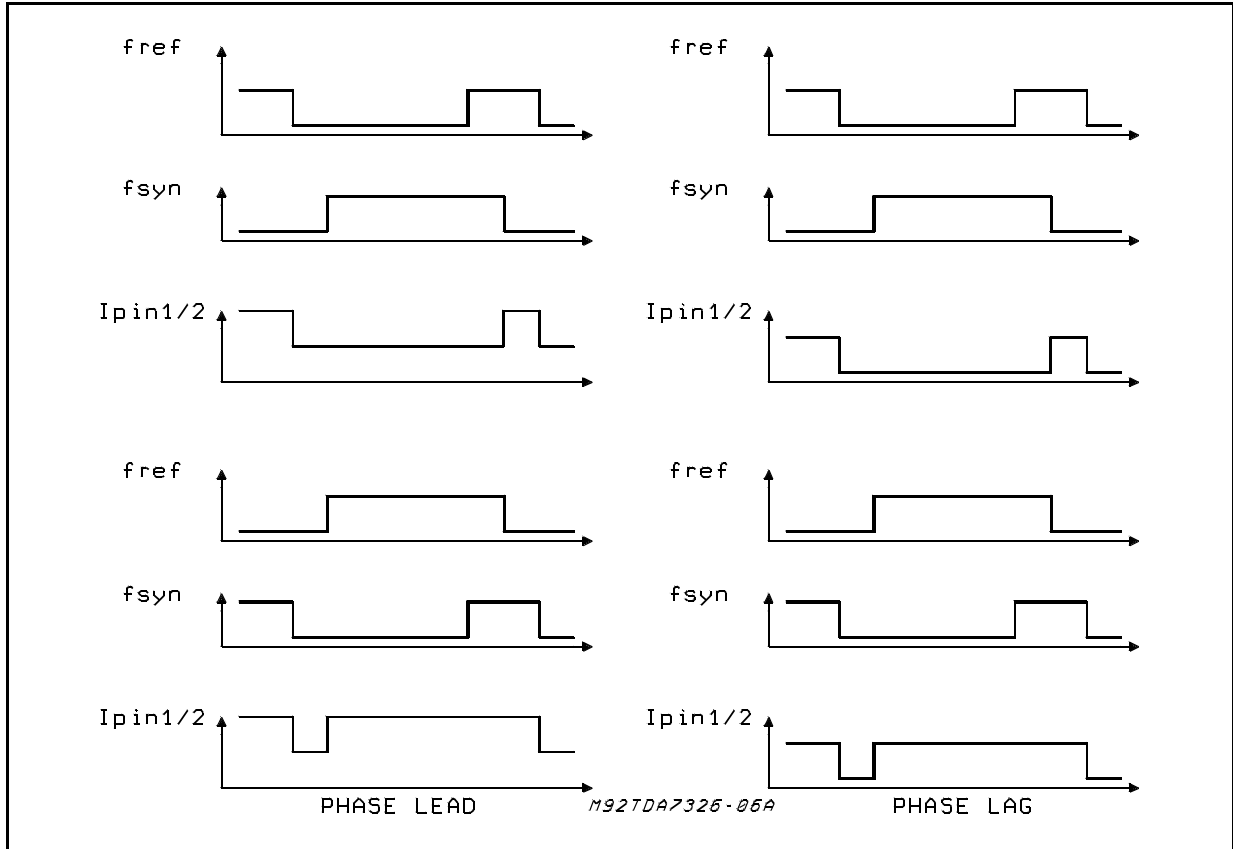
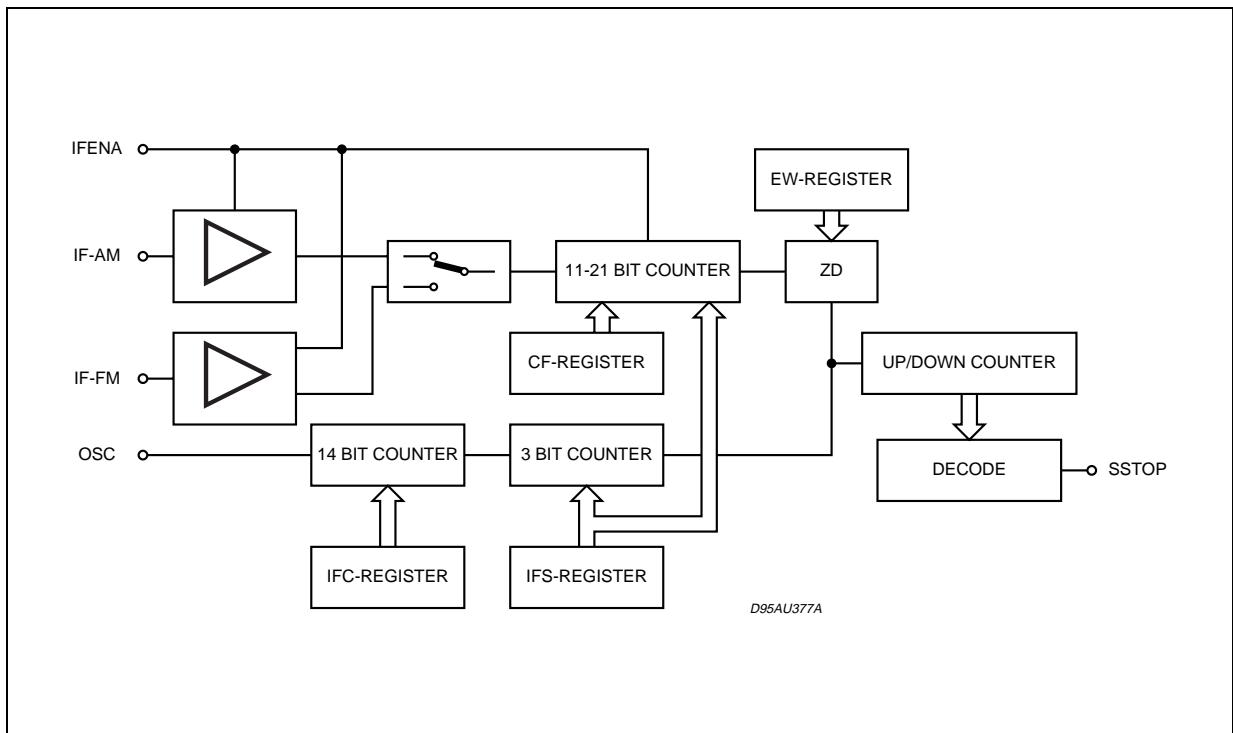

Figure 4. IF Counter internal block diagram



## TDA7427A

The negative input is switchable to three input pins ( LPIN 1, LPIN 2 and LPIN 3) to increase the flexibility in application. This feature allows two separate active filters for different applications

A logical "1" in the LPIN 1/2 register activates pin LPIN 1, otherwise pin LPIN 2 is active. While the high current mode is activated LPIN 3 is switched on.

### INLOCK DETECTOR

The charge pump can be switched in low current mode either via software or automatically by the inlock detector by setting bit LDENA to "1".

The charge pump is forced in low current mode when a phase difference of 10-40  $\mu$ sec is reached.

A phase difference larger then the programmed values will switch the charge pump immediately in the high current mode.

Programmable delays are available for inlock detection.

### IF COUNTER SYSTEM (AM/FM/AM - UPC MODES)

The if counter works in modes controlled by IFCM register (see table):

IFCM1	IFCM0	FUNCTION
0	0	NOT USED
0	1	FM MODE
1	0	AM MODE
1	1	10.7MHz AM UP CONVERSION MODE

Typical input impedance for IF inputs is 4K $\Omega$ .

A sample timer to generate the gate signal for the main counter is build with a 14-bit programmable counter to have the possibility to use any crystal oscillator frequency. In FM mode 6.25KHz in AM

mode a 1KHz signal is generated. This is followed by an asynchronous divider to generate different sampling times (see fig. 4).

### Intermediate Frequency Main Counter

This counter is a 11/21 bits synchronous autoreload down-counter. Four bits are programmable to have the possibility for an adjust to the frequency of the CF filter. The counter length is automatically adjusted to the chosen sampling time and the counter mode (AM, FM, AM-UPC).

At the start the counter will be loaded with a defined value which is an equivalent to the divider value ( $t_{\text{sample}} \cdot f_{\text{IF}}$ ).

If a correct frequency is applied to the IF counter frequency inputs IF-AM IF-FM, at the end of the sampling time the main counter is changing its state from 0 H to 1FFFFFFH.

This is detected by a control logic. The frequency range inside which a successful count results is detected is adjustable by bits EW 0,1,2.

### Adjustment of the Measurement Sequence Time

The precision of the measurements is adjustable by controlling the discrimination window . This is adjustable by programming the control registers EW0...EW2.

The measurement time per cycle is adjustable by setting the Register IFS0 - IFS2.

### Adjust of the Frequency Value

The center frequency of the discrimination window is adjustable by the control register "CF0" to "CF4". (see data byte specification).

### Port Extension and additional functions

Five digital open collector outputs and one digital push-pull output are available in application mode. This digital ports are controlled by the data bits DOUT1-DOUT6.

Figure 5. I<sup>2</sup>C Bus timing diagram

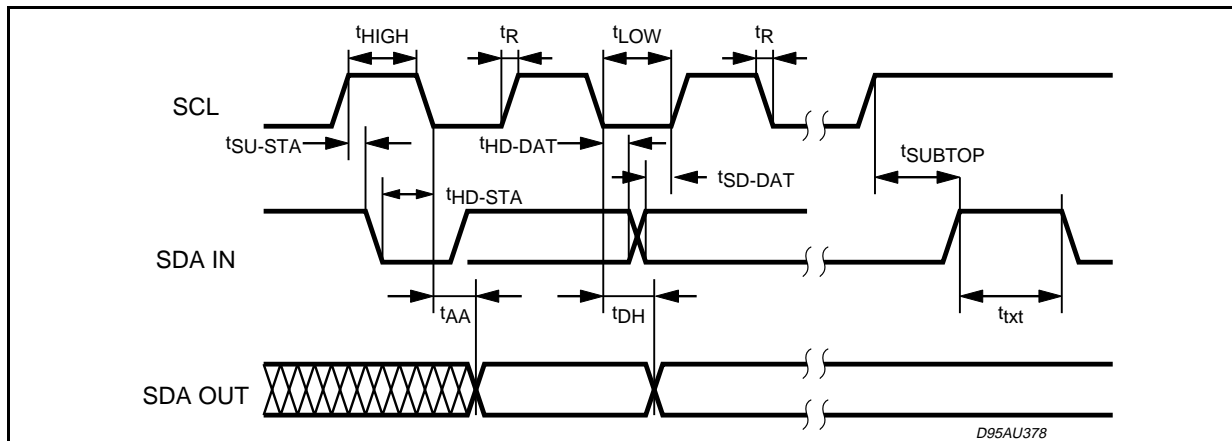

### I<sup>2</sup>C BUS INTERFACE DESCRIPTION

The TDA7427A supports the I<sup>2</sup>C bus protocol. This protocol defines any device that sends data into the bus as a transmitter and the receiving device as the receiver. The device that controls the transfer is the master and the device being controlled is the slave. The master always initiates data transfer and provides the clock to transmit or receive operations.

#### Data Transition

Data transition on the SDA line must only occur when the clock SCL is low. SDA transitions while SCL is high will be interpreted as START or STOP condition.

#### Start Condition

A start condition is defined by a HIGH to LOW transition of the SDA line while SCL is at a stable HIGH level. This START condition must precede any command and initiate a data transfer onto the bus. The TDA7427A continuously monitors the SDA and SCL lines for a valid START and will not respond to any command if this condition has not been met.

#### Stop Condition

A STOP condition is defined by a LOW to HIGH transition of the SDA while the SCL line is at a stable HIGH level. This condition terminate the communication between the devices and forces the bus interface of the TDA7427A into the initial condition.

#### Acknowledge

Indicates a successful data transfer. The transmit-

ter will release the bus after sending 8 bit of data. During the 9th clock cycle the receiver will pull the SDA line to LOW level to indicate it has receive the eight bits of data correctly.

#### Data transfer

During data transfer the TDA7427A samples the SDA line on the leading edge of the SCL clock. Therefore, for proper device operation the SDA line must be stable during the SCL LOW to HIGH transition.

#### Device Addressing

To start the communication between two devices, the bus master must initiate a start instruction sequence, followed by an eight bit word corresponding to the address of the device it is addressing. The most significant 6 bits of the slave address are the device type identifier.

The TDA7427A frequency synthesizer device type is fixed as "110001"

The next significant bit is used to address a particular device of the previous defined type connected to the bus. The state of the hardwired A0 pin defines the state of this address bit. So up to two devices could be connected on the same bus. The last bit of the instruction defines the type of operation to be performed:

- When set to "1", a read operation is selected
- When set to "0", a write operation is selected

The chip selection is accomplished by setting the bit of the chip address to the corresponding status of the A0 input.

All TDA7427A connected to the bus will compare their own hardwired address with the slave ad-

Figure 6. Application with two loop filters

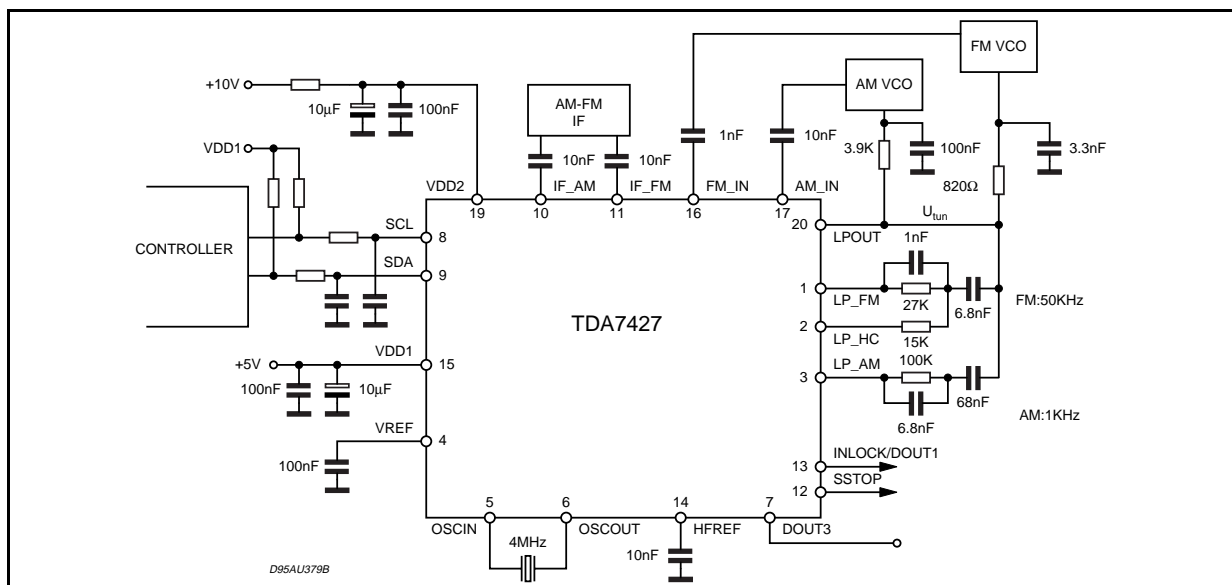

## TDA7427A

dress being transmitted.

After this comparison, the TDA7427A will generate an "acknowledge" on the SDA line and will perform either a read or write operation according to the state of R/W bit.

### Write Operation

Following a START condition the master sends a slave address word with the R/W bit set to "0". The TDA7427A will "acknowledge" after this first transmission and wait for a second word (the word address field).

This 8 bit address field provides an access to any of the 8 internal addresses. Upon receipt of the word address the TDA7427A slave device will respond with an "acknowledge". At this time, all the

following words transmitted to the TDA7427A will be considered as Data. The internal address will be automatically incremented. After each word receipt the TDA7427A will answer with an "acknowledge".

### SOFTWARE SPECIFICATION

#### I<sup>2</sup>C Protocol

The interface protocol comprises:

- A start condition (s)
- A chip address byte (the LSB determines read/write transmission)
- A sub-address byte.
- A sequence of data (N-bytes + acknowledge)
- A stop condition (P)

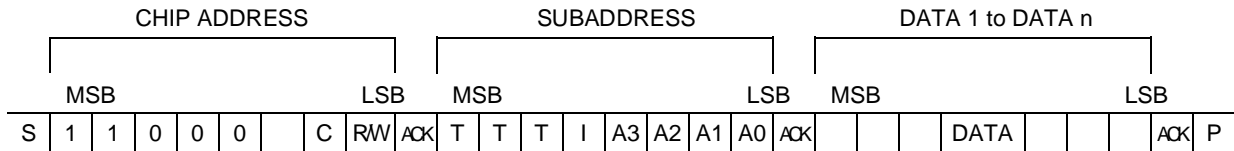

ACK = Acknowledge

S = Start

P = Stop

I = Auto Increment

C = chip select

T = used for testing (in application mode they have to be "0")

MAX CLOCK SPEED 400kbits/s

### CHIP ADDRESS

MSB				LSB				FUNCTION
1	1	0	0	0	1	C	1	
						0		ADDR pin open
						1		ADDR pin connected to V <sub>DD</sub>

### SUBADDRESS

MSB				LSB				FUNCTION
T3	T2	T1	I	A3	A2	A1	A0	
				0	0	0	0	Charge pump control
				0	0	0	1	PLL counter 1 (LSB)
				0	0	1	0	PLL counter 2 (MSB)
				0	0	1	1	PLL reference counter 1 (LSB)
				0	1	0	0	PLL reference counter 2 (MSB)
				0	1	0	1	PLL lockdetector control and PLL mode select
				0	1	1	0	IFC reference counter 1 (LSB)
				0	1	1	1	IFC reference counter 2 (MSB) and IFC mode select
				1	0	0	0	IF counter control 1
				1	0	0	1	IF counter control 2
				1	0	1	0	Oscillator adjust
				1	0	1	1	Port extension
			0					page mode off
			1					page mode enabled

T1, T2, T3 used for testing, in application mode they have to be "0"

## Data Byte Specification

## CHARGE PUMP CONTROL

MSB				LSB				FUNCTION
D7	D6	D5	D4	D3	D2	D1	D0	
				0	0	0	0	High current = 0mA
				0	0	0	1	High current = 0.5mA
				0	0	1	0	High current = 1.0mA
				0	0	1	1	High current = 1.5mA
				0	1	0	0	High current = 2.0mA
				0	1	0	1	High current = 2.5mA
				0	1	1	0	High current = 3.0mA
				0	1	1	1	High current = 3.5mA
				1	0	0	0	High current = 4.0mA
				1	0	0	1	High current = 4.5mA
				1	0	1	0	High current = 5.0mA
				1	0	1	1	High current = 5.5mA
				1	1	0	0	High current = 6.0mA
				1	1	0	1	High current = 6.5mA
				1	1	1	0	High current = 7.0mA
				1	1	1	1	High current = 7.5mA
		0	0					Low current = 0 $\mu$ A
		0	1					Low current = 50 $\mu$ A
		1	0					Low current = 100 $\mu$ A
		1	1					Low current = 150 $\mu$ A
	0							Select low Current
	1							Select high Current
1								Select loop filter LP_FM
0								Select loop filter LP_AM
LPIN1/2	CURRH	B1	B0	A3	A2	A1	A0	Subaddress = 00H

## PLL COUNTER 1 (LSB)

MSB				LSB				FUNCTION
D7	D6	D5	D4	D3	D2	D1	D0	
0	0	0	0	0	0	0	0	LSB = 0
0	0	0	0	0	0	0	1	LSB = 1
0	0	0	0	0	0	1	0	LSB = 2
1	1	1	1	1	1	0	0	LSB = 252
1	1	1	1	1	1	0	1	LSB = 253
1	1	1	1	1	1	1	0	LSB = 254
1	1	1	1	1	1	1	1	LSB = 255
PC7	PC6	PC5	PC4	PC3	PC2	PC1	PC0	Bit name Subaddress = 01H

## TDA7427A

### PLL COUNTER 2 (MSB)

MSB								LSB		FUNCTION
D7	D6	D5	D4	D3	D2	D1	D0			
0	0	0	0	0	0	0	0	MSB = 0		
0	0	0	0	0	0	0	1	MSB = 256		
0	0	0	0	0	0	1	0	MSB = 512		
1	1	1	1	1	1	0	0	MSB = 64768		
1	1	1	1	1	1	0	1	MSB = 65024		
1	1	1	1	1	1	1	0	MSB = 65280		
1	1	1	1	1	1	1	1	MSB = 65536		
PC15	PC14	PC13	PC12	PC11	PC10	PC9	PC8	Bit name	Subaddress = 02H	

Swallow mode:  $f_{vco}/f_{syn} = LSB + MSB + 32$

Direct mode:  $f_{vco}/f_{syn} = LSB + MSB + 1$

### PLL REFERENCE COUNTER 1 (LSB)

MSB								LSB		FUNCTION
D7	D6	D5	D4	D3	D2	D1	D0			
0	0	0	0	0	0	0	0	LSB = 0		
0	0	0	0	0	0	0	1	LSB = 1		
0	0	0	0	0	0	1	0	LSB = 2		
1	1	1	1	1	1	0	0	LSB = 252		
1	1	1	1	1	1	0	1	LSB = 253		
1	1	1	1	1	1	1	0	LSB = 254		
1	1	1	1	1	1	1	1	LSB = 255		
RC7	RC6	RC5	RC4	RC3	RC2	RC1	RC0	Bit name	Subaddress = 03H	

### PLL REFERENCE COUNTER 2 (MSB)

MSB								LSB		FUNCTION
D7	D6	D5	D4	D3	D2	D1	D0			
0	0	0	0	0	0	0	0	MSB = 0		
0	0	0	0	0	0	0	1	MSB = 256		
0	0	0	0	0	0	1	0	MSB = 512		
1	1	1	1	1	1	0	0	MSB = 64768		
1	1	1	1	1	1	0	1	MSB = 65024		
1	1	1	1	1	1	1	0	MSB = 65280		
1	1	1	1	1	1	1	1	MSB = 65536		
RC15	RC14	RC13	RC12	RC11	RC10	RC9	RC8	Bit name	Subaddress = 04H	

$f_{osc}/f_{REF} = LSB + MSB + 1$

## LOCK DETECTOR &amp; PLL MODE CONTROL

MSB				LSB				FUNCTION
D7	D6	D5	D4	D3	D2	D1	D0	
						0	0	PLL standby mode
						0	1	PLL AM swallow mode
						1	0	PLL AM direct mode
						1	1	PLL FM mode
				0	0			PD phase difference threshold 10ns
				0	1			PD phase difference threshold 20ns
				1	0			PD phase difference threshold 30ns
				1	1			PD phase difference threshold 40ns
		0	0					Not used in application mode
		0	1					Activation delay = 4 · fref
		1	0					Activation delay = 6 · fref
		1	1					Activation delay = 8 · fref
	0							Digital output 1 at pin "dout1/inlock"
	1							Inlock information at pin "dout1/inlock"
0								No lock detector controlled chargepump
1								Lock detector controlled chargepump
LDENA	INLOCK	D3	D2	D1	D0	PM1	PM0	Bit name Subaddress = 05H

## IF COUNTER REFERENCE CONTROL 1 (LSB)

MSB				LSB				FUNCTION
D7	D6	D5	D4	D3	D2	D1	D0	
0	0	0	0	0	0	0	0	LSB = 0
0	0	0	0	0	0	0	1	LSB = 1
0	0	0	0	0	0	1	0	LSB = 2
1	1	1	1	1	1	0	0	LSB = 252
1	1	1	1	1	1	0	1	LSB = 253
1	1	1	1	1	1	1	0	LSB = 254
1	1	1	1	1	1	1	1	LSB = 255
IRC7	IRC6	IRC5	IRC4	IRC3	IRC2	IRC1	IRC0	Bit name Subaddress = 06H

## TDA7427A

### IF COUNTER REFERENCE CONTROL 2 (MSB) AND IF COUNTER MODE SELECT

MSB								LSB	FUNCTION
D7	D6	D5	D4	D3	D2	D1	D0		
0	0	0	0	0	0	0	0	MSB = 0	
0	0	0	0	0	0	0	1	MSB = 256	
0	0	0	0	0	0	1	0	MSB = 512	
		1	1	1	1	0	1	MSB = 15616	
		1	1	1	1	1	0	MSB = 15872	
		1	1	1	1	1	1	MSB = 16128	
0	0							NOT USED IN APPLICATION MODE	
0	1							IF counter FM mode	
1	0							IF counter AM mode	
1	1							IF counter AM 10.7MHz upconversion mode	
IFCM1	IFCM0	IRC13	IRC12	IRC11	IRC10	IRC9	IRC8	Bit name Subaddress = 07H	

$$f_{osc}/f_{tim} = LSB + MSB + 1$$

### IF COUNTER CONTROL 1

MSB								LSB	FUNCTION
D7	D6	D5	D4	D3	D2	D1	D0		
					0	0	0	don't use	
					0	0	1	don't use	
					0	1	1	EW delta f = ±6.25kHz (FM); ±1kHz (AM; AM-UPC)	
					1	0	0	EW delta f = ±12.5kHz (FM); ±2kHz (AM; AM-UPC)	
					1	0	1	EW delta f = ±25kHz (FM); ±4kHz (AM; AM-UPC)	
					1	1	0	EW delta f = ±50Hz (FM); ±8kHz (AM; AM-UPC)	
					1	1	1	EW delta f = ±100kHz (FM); ±16kHz (AM; AM-UPC)	
	X	X	X	X				don't use	
0								IF counter disabled / stand by	
1								IF counter enabled	
FENA	FR3	FR2	FR1	FR0	EW2	EW1	EW0	Bit name Subaddress = 08H	



## IF COUNTER CONTROL 2

MSB				LSB				FUNCTION
D7	D6	D5	D4	D3	D2	D1	D0	
			0	0	0	0	0	fcenter = 10.60000MHz (FM) 448KHz (AM) 10.688MHz (AM UPC)
			0	0	0	0	1	fcenter = 10.60625MHz (FM) 449KHz (AM) 10.689MHz (AM UPC)
			0	0	0	1	0	fcenter = 10.61250MHz (FM) 450KHz (AM) 10.690MHz (AM UPC)
			0	0	0	1	1	fcenter = 10.61875MHz (FM) 451KHz (AM) 10.691MHz (AM UPC)
			0	0	1	0	0	fcenter = 10.62500MHz (FM) 452KHz (AM) 10.692MHz (AM UPC)
			0	0	1	0	1	fcenter = 10.63125MHz (FM) 453KHz (AM) 10.693MHz (AM UPC)
			0	0	1	1	0	fcenter = 10.63750MHz (FM) 454KHz (AM) 10.694MHz (AM UPC)
			0	0	1	1	1	fcenter = 10.64375MHz (FM) 455KHz (AM) 10.695MHz (AM UPC)
			0	1	0	0	0	fcenter = 10.65000MHz (FM) 456KHz (AM) 10.696MHz (AM UPC)
			0	1	0	0	1	fcenter = 10.65625MHz (FM) 457KHz (AM) 10.697MHz (AM UPC)
			0	1	0	1	0	fcenter = 10.66250MHz (FM) 458KHz (AM) 10.698MHz (AM UPC)
			0	1	0	1	1	fcenter = 10.66875MHz (FM) 459KHz (AM) 10.699MHz (AM UPC)
			0	1	1	0	0	fcenter = 10.67500MHz (FM) 460KHz (AM) 10.700MHz (AM UPC)
			0	1	1	0	1	fcenter = 10.68125MHz (FM) 461KHz (AM) 10.701MHz (AM UPC)
			0	1	1	1	0	fcenter = 10.68750MHz (FM) 462KHz (AM) 10.702MHz (AM UPC)
			0	1	1	1	1	fcenter = 10.69375MHz (FM) 463KHz (AM) 10.703MHz (AM UPC)
			1	0	0	0	0	fcenter = 10.70000MHz (FM) 464KHz (AM) 10.704MHz (AM UPC)
			1	0	0	0	1	fcenter = 10.70625MHz (FM) 465KHz (AM) 10.705MHz (AM UPC)
			1	0	0	1	0	fcenter = 10.71250MHz (FM) 466KHz (AM) 10.706MHz (AM UPC)
			1	0	0	1	1	fcenter = 10.71875MHz (FM) 467KHz (AM) 10.707MHz (AM UPC)
			1	0	1	0	0	fcenter = 10.72500MHz (FM) 468KHz (AM) 10.708MHz (AM UPC)
			1	0	1	0	1	fcenter = 10.73125MHz (FM) 469KHz (AM) 10.709MHz (AM UPC)
			1	0	1	1	0	fcenter = 10.73750MHz (FM) 470KHz (AM) 10.710MHz (AM UPC)
			1	0	1	1	1	fcenter = 10.74375MHz (FM) 471KHz (AM) 10.711MHz (AM UPC)
			1	1	0	0	0	fcenter = 10.75000MHz (FM) 472KHz (AM) 10.712MHz (AM UPC)
			1	1	0	0	1	fcenter = 10.75625MHz (FM) 473KHz (AM) 10.713MHz (AM UPC)
			1	1	0	1	0	fcenter = 10.76250MHz (FM) 474KHz (AM) 10.714MHz (AM UPC)
			1	1	0	1	1	fcenter = 10.76875MHz (FM) 475KHz (AM) 10.715MHz (AM UPC)
			1	1	1	0	0	fcenter = 10.77500MHz (FM) 476KHz (AM) 10.716MHz (AM UPC)
			1	1	1	0	1	fcenter = 10.78125MHz (FM) 477KHz (AM) 10.717MHz (AM UPC)
			1	1	1	1	0	fcenter = 10.78750MHz (FM) 478KHz (AM) 10.718MHz (AM UPC)
			1	1	1	1	1	fcenter = 10.79375MHz (FM) 479KHz (AM) 10.719MHz (AM UPC)
1	1	1						tsample = 160μs (FM mode); 1ms (AM; AM-UPC)
1	1	0						tsample = 320μs (FM mode); 2ms (AM; AM-UPC)
1	0	1						tsample = 640μs (FM mode); 4ms (AM; AM-UPC)
1	0	0						tsample = 1.280ms (FM mode); 8ms (AM; AM-UPC)
0	1	1						tsample = 2.560ms (FM mode); 16ms (AM; AM-UPC)
0	1	0						tsample = 5.120ms (FM mode); 32ms (AM; AM-UPC)
0	0	1						tsample = 10.240ms (FM mode); 64ms (AM; AM-UPC)
0	0	0						tsample = 20.480ms (FM mode); 128ms (AM; AM-UPC)
IFS2	IFS1	IFS0	CF4	CF3	CF2	CF1	CF0	bit same <span style="float: right;">Subaddress = 09H</span>

## TDA7427A

### OSCILLATOR ADJUST

MSB								LSB	FUNCTION
D7	D6	D5	D4	D3	D2	D1	D0		
X	X	X	0	0	0	0	0	Cload 1,2 = 3pF	
X	X	X	0	0	0	0	1	Cload 1,2 = 4.25pF	
X	X	X	0	0	0	1	0	Cload 1,2 = 5.5pF	
X	X	X	0	0	0	1	1	Cload 1,2 = 6.75pF	
X	X	X	0	0	1	0	0	Cload 1,2 = 8pF	
X	X	X	0	0	1	0	1	Cload 1,2 = 9.25pF	
X	X	X	0	0	1	1	0	Cload 1,2 = 10.5pF	
X	X	X	0	0	1	1	1	Cload 1,2 = 11.75pF	
X	X	X	0	1	0	0	0	Cload 1,2 = 13pF	
X	X	X	0	1	0	0	1	Cload 1,2 = 14.25pF	
X	X	X	0	1	0	1	0	Cload 1,2 = 15.5pF	
X	X	X	0	1	0	1	1	Cload 1,2 = 16.75pF	
X	X	X	0	1	1	0	0	Cload 1,2 = 18pF	
X	X	X	0	1	1	0	1	Cload 1,2 = 19.25pF	
X	X	X	0	1	1	1	0	Cload 1,2 = 20.5pF	
X	X	X	0	1	1	1	1	Cload 1,2 = 21.75pF	
X	X	X	1	0	0	0	0	Cload 1,2 = 23pF	
X	X	X	1	0	0	0	1	Cload 1,2 = 24.25pF	
X	X	X	1	0	0	1	0	Cload 1,2 = 25.5pF	
X	X	X	1	0	0	1	1	Cload 1,2 = 26.75pF	
X	X	X	1	0	1	0	0	Cload 1,2 = 28pF	
X	X	X	1	0	1	0	1	Cload 1,2 = 29.25pF	
X	X	X	1	0	1	1	0	Cload 1,2 = 30.5pF	
X	X	X	1	0	1	1	1	Cload 1,2 = 31.75pF	
X	X	X	1	1	0	0	0	Cload 1,2 = 33pF	
X	X	X	1	1	0	0	1	Cload 1,2 = 34.25pF	
X	X	X	1	1	0	1	0	Cload 1,2 = 35.5pF	
X	X	X	1	1	0	1	1	Cload 1,2 = 36.75pF	
X	X	X	1	1	1	0	0	Cload 1,2 = 38pF	
X	X	X	1	1	1	0	1	Cload 1,2 = 39.25pF	
X	X	X	1	1	1	1	0	Cload 1,2 = 40.5pF	
X	X	X	1	1	1	1	1	Cload 1,2 = 41.75pF	
-	-	-	OSC4	OSC3	OSC2	OSC1	OSC0	Bit name Subaddress = 0AH	

### PORT EXTENSION CONTROL

MSB								LSB	FUNCTION
D7	D6	D5	D4	D3	D2	D1	D0		
							0	CMOS push-pull DOUT1 low	
							1	CMOS push-pull DOUT1 high	
							0	NPN opencollector DOUT2 inactive	
							1	NPN opencollector DOUT2 active	
							0	NPN opencollector DOUT6 inactive	
							1	NPN opencollector DOUT6 active	
				0				NPN opencollector DOUT5 inactive	
				1				NPN opencollector DOUT5 active	
			0					NPN opencollector DOUT4 inactive	
			1					NPN opencollector DOUT4 active	
		0						NPN opencollector DOUT3 inactive	
		1						NPN opencollector DOUT3 active	
0	0							always "0" in application mode	
-	-	DOUT3	DOUT4	DOUT5	DOUT6	DOUT2	DOUT1	Bit name Subaddress = 0BH	

DIM.	mm			inch		
	MIN.	TYP.	MAX.	MIN.	TYP.	MAX.
A			1.20			0.048
A1	0.05		0.15	0.002		0.006
A2	0.80	1.00	1.05	0.031	0.039	0.041
b	0.19		0.30	0.007		0.012
c	0.09		0.20	0.0035		0.008
D	9.60	9.70	9.80	0.378	0.382	0.386
E		6.40			0.252	
e		0.65			0.026	
E1	4.30	4.40	4.50	0.169	0.173	0.177
L	0.45	0.60	0.75	0.018	0.024	0.030
S	0° (min.) 8° (max.)					

**OUTLINE AND MECHANICAL DATA**

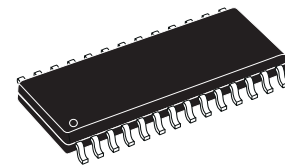

**TSSO28 (Thin Shrink)**

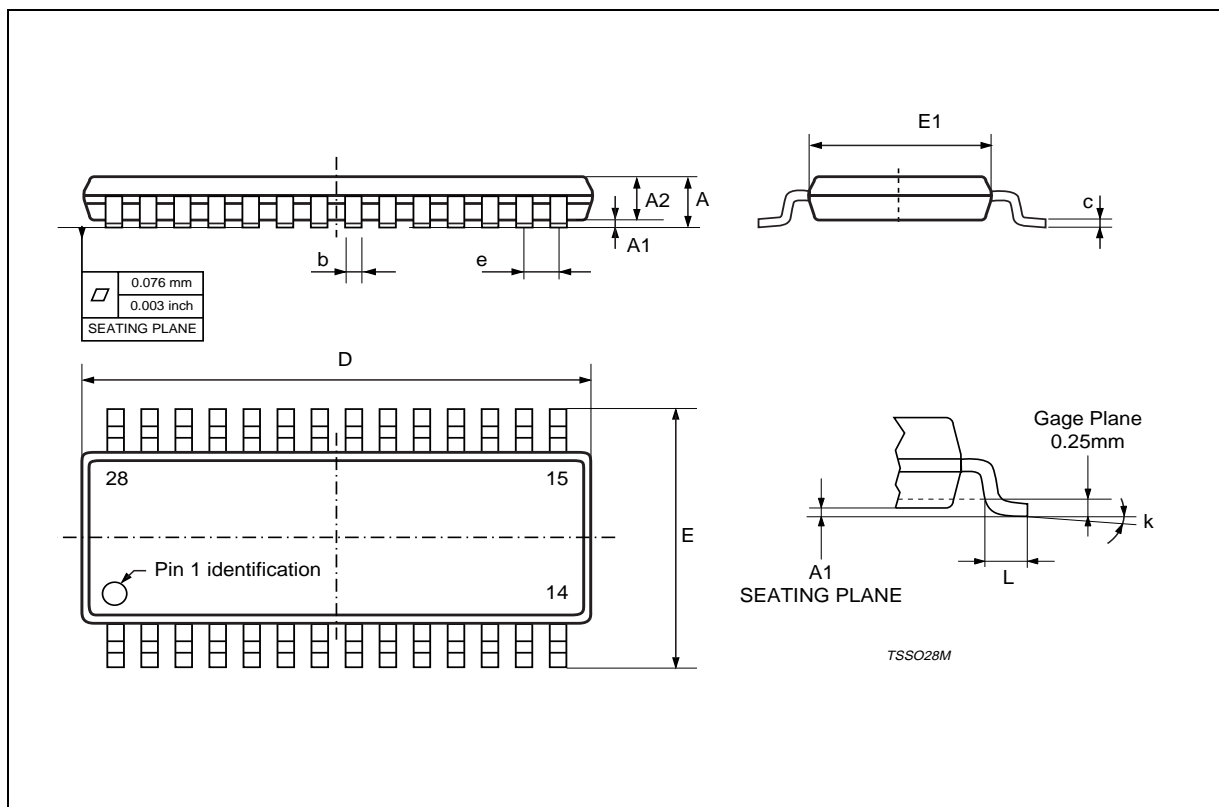

# TDA7427A

DIM.	mm			inch		
	MIN.	TYP.	MAX.	MIN.	TYP.	MAX.
A			2.65			0.104
a1	0.1		0.3	0.004		0.012
b	0.35		0.49	0.014		0.019
b1	0.23		0.32	0.009		0.013
C		0.5			0.020	
c1	45° (typ.)					
D	17.7		18.1	0.697		0.713
E	10		10.65	0.394		0.419
e		1.27			0.050	
e3		16.51			0.65	
F	7.4		7.6	0.291		0.299
L	0.4		1.27	0.016		0.050
S	8° (max.)					

## OUTLINE AND MECHANICAL DATA

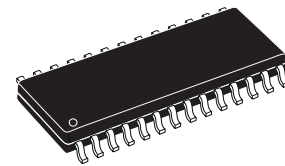

**SO28**

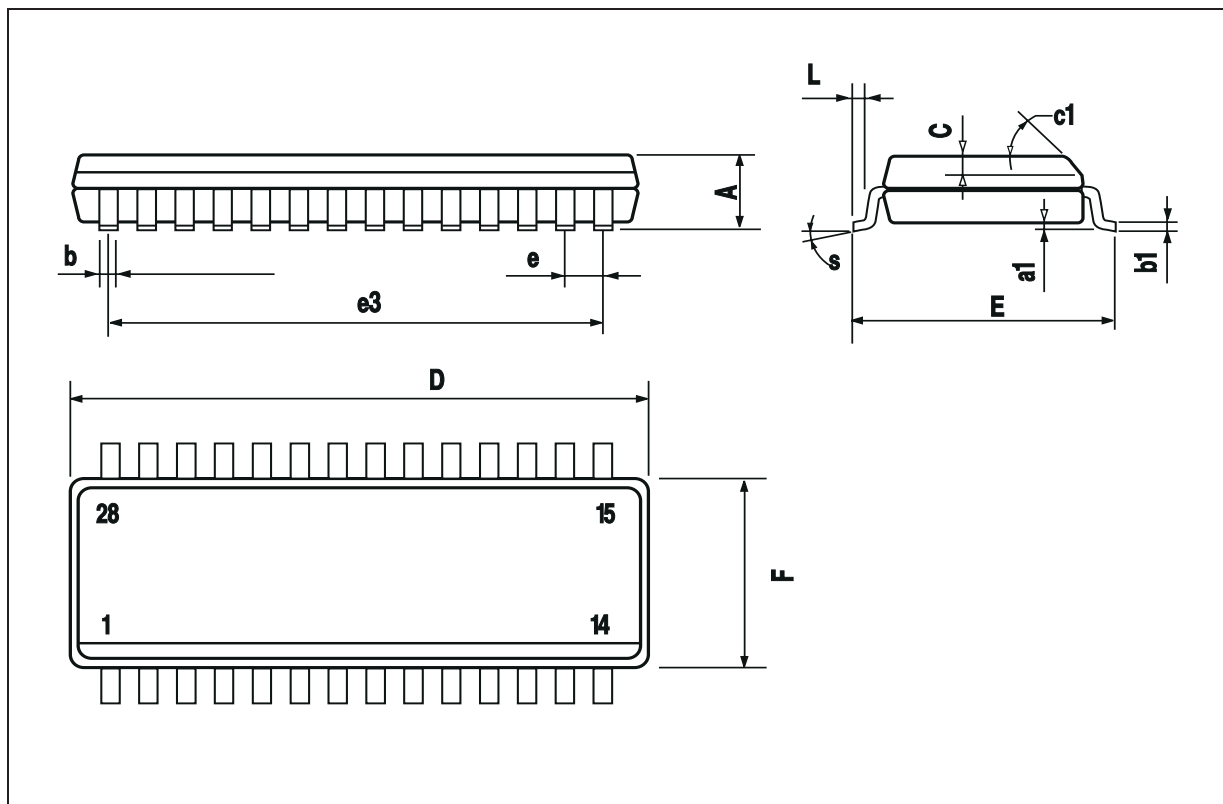

Information furnished is believed to be accurate and reliable. However, STMicroelectronics assumes no responsibility for the consequences of use of such information nor for any infringement of patents or other rights of third parties which may result from its use. No license is granted by implication or otherwise under any patent or patent rights of STMicroelectronics. Specification mentioned in this publication are subject to change without notice. This publication supersedes and replaces all information previously supplied. STMicroelectronics products are not authorized for use as critical components in life support devices or systems without express written approval of STMicroelectronics.

The ST logo is a registered trademark of STMicroelectronics

© 2002 STMicroelectronics – Printed in Italy – All Rights Reserved

STMicroelectronics GROUP OF COMPANIES

Australia - Brazil - Canada - China - Finland - France - Germany - Hong Kong - India - Israel - Italy - Japan - Malaysia - Malta - Morocco - Singapore - Spain - Sweden - Switzerland - United Kingdom - United States.

<http://www.st.com>