



TDA7515

RF-FRONTEND FOR AM/FM-DSP-CARRADIOS WITH IF SAMPLING

PRODUCT PREVIEW

- RF AGC generation by RF and IF detection
- I/Q Mixer for FM IF 10.7MHz with image rejection and programmable IF tank adjust for FM and AM
- Preamplifier and mixer for IF 10.7MHz AM upconversion
- VCO and programmable divider for "world receiver"
- Programmable controlled IF-gain stage

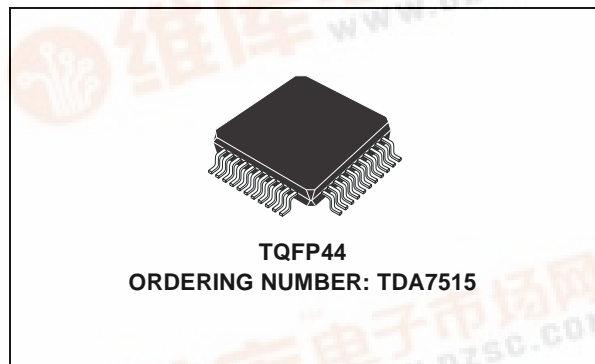

Additional features:

- High performance fast PLL for RDS-system
- Electronic alignment for the preselection stages
- All functions bus-controlled

AM/FM - DSP carradios with 10.7MHz - IF sampling. It contains mixer and IF amplifiers for AM and FM, VCO and PLL synthesizer on a single chip.

Use of BICMOS technology allows the implementation of several tuning functions and a minimum of external components.

DESCRIPTION

The frontend is a high performance tuner circuit for

1 BLOCK DIAGRAM

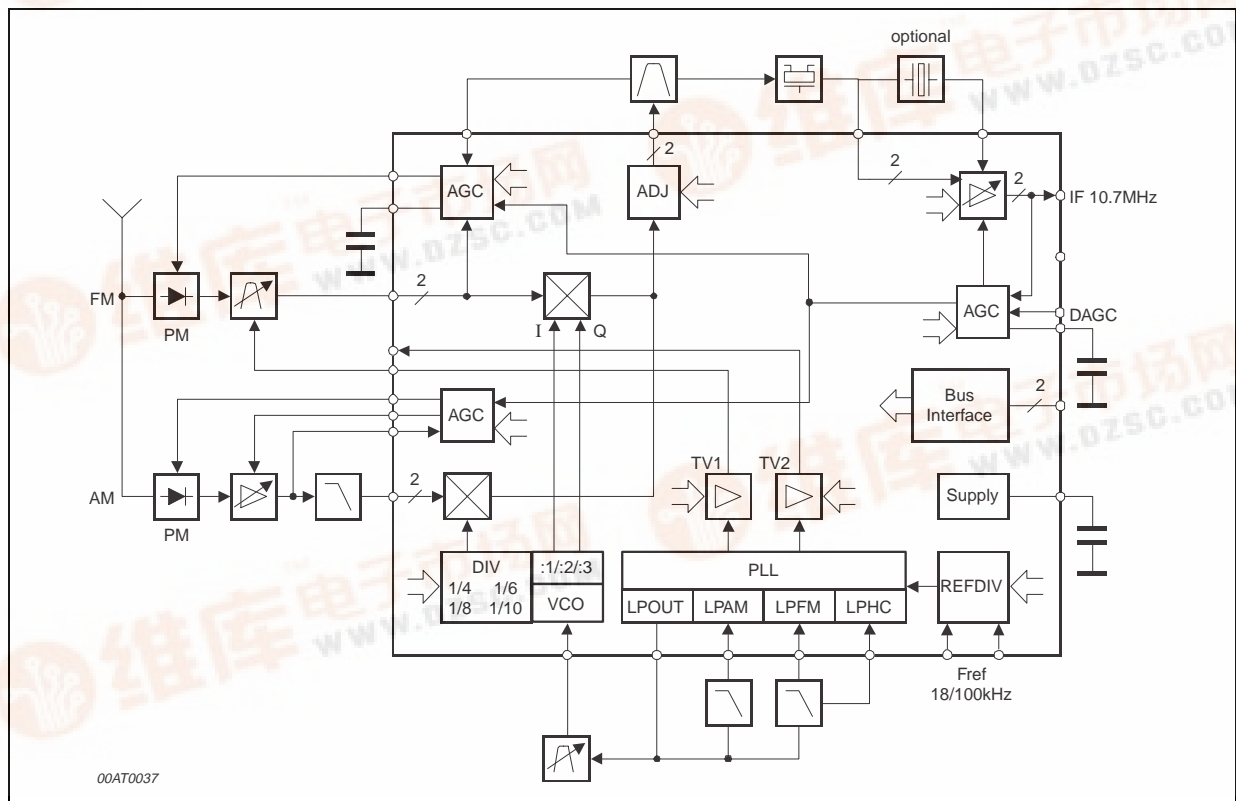

2 PIN CONNECTION

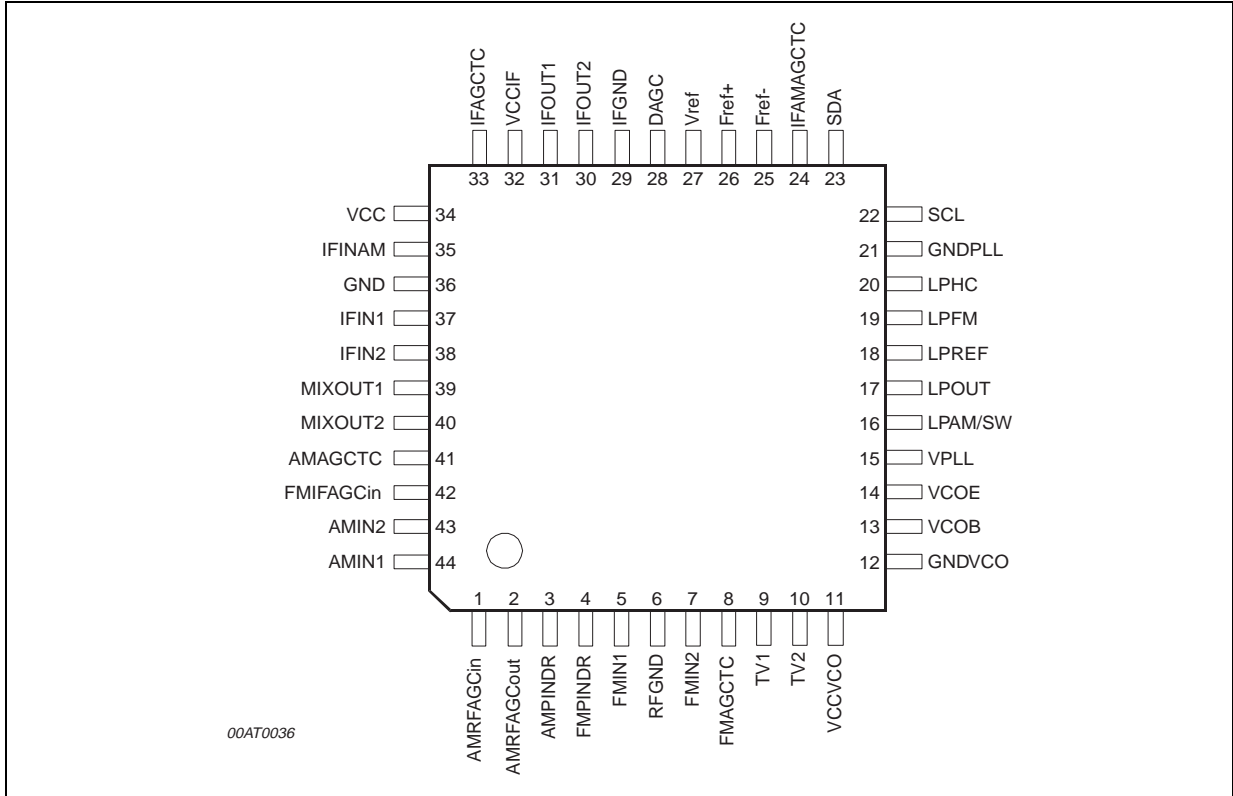

3 PIN DESCRIPTION

Pin No.	Pin Name	Function
1	AMRFAGCin	AM AGC Input for RF detection
2	AMRFAGCout	AM AGC output for RF AGC
3	AMPINDR	AM AGC PIN-diode driver
4	FMPINDR	FM AGC Pindiode driver
5	FMIN1	FM Mixer Input 1
6	RFGND	RF Ground
7	FMIN2	FM Mixer Input 2
8	FMAGCTC	FM AGC time constant
9	TV1	Tuning voltage 1 output
10	TV2	Tuning voltage 2 output
11	VCCVCO	Supply Voltage VCO
12	GNDVCO	VCO Ground
13	VCOB	Base VCO
14	VCOE	Emitter VCO
15	VPLL	PLL Supply Voltage
16	LPAM/SW	OP AMP Input to PLL Loop Filter AM / switch output (optional)
17	LPOUT	OPAMP output to PLL Loop Filter
18	LPREF	Voltage Reference for PLL
19	LPFM	OP AMP Input to PLL Loop Filter FM
20	LPHC	High Current PLL Loop Filter

3 PIN DESCRIPTION (continued)

Pin No.	Pin Name	Function
21	GNDPLL	PLL Ground
22	SCL	Bus connection (IIC clock)
23	SDA	Bus connection (IIC data)
24	IFAMAGCTC	Time constant for AM IF AGC
25	Fref-	Reference frequency input
26	Fref+	Reference frequency input
27	Vref	Reference voltage 5V
28	DAGC	Digital keying AGC input
29	IFGND	IF Ground
30	IFOUT2	IF amplifier output
31	IFOUT1	IF amplifier output
32	VCCIF	Supply voltage for IF output
33	IFAGCTC	IF AGC time constant
34	VCC	Supply voltage
35	IFINAM	IF input for narrowband AM
36	GND	Ground
37	IFIN1	IF Input - signal
38	IFIN2	IF Input - blocked
39	MIXOUT1	Mixer Output
40	MIXOUT2	Mixer Output
41	AMAGCTC	AM AGC time constant
42	FMIFAGCin	IF input for FM AGC
43	AMIN2	AM RF Input
44	AMIN1	AM RF Input

4 THERMAL DATA

Symbol	Parameter	Values			Unit
		Min.	Typ.	Max.	
$R_{th(j-a)}$	Thermal resistance			85	°C/W
T_{amb}	Ambient temperature	-40		85	°C
T_{stg}	Storage temperature	-55		150	°C

5 ABSOLUTE MAXIMUM RATINGS

Symbol	Parameter	Value	Unit
V_{CCIF}	Supply voltage for IF-interface	12	V
V_{PLL}	PLL supply voltage	12	V
V_{CCVCO}	VCO supply voltage	12	V
V_{CC}	Supply voltage	12	V
$V_{MIXOUT1/2}$	Open collector voltage	12	V

TDA7515

DIM.	mm			inch		
	MIN.	TYP.	MAX.	MIN.	TYP.	MAX.
A			1.60			0.063
A1	0.05		0.15	0.002		0.006
A2	1.35	1.40	1.45	0.053	0.055	0.057
B	0.30	0.37	0.45	0.012	0.014	0.018
C	0.09		0.20	0.004		0.008
D		12.00			0.472	
D1		10.00			0.394	
D3		8.00			0.315	
e		0.80			0.031	
E		12.00			0.472	
E1		10.00			0.394	
E3		8.00			0.315	
L	0.45	0.60	0.75	0.018	0.024	0.030
L1		1.00			0.039	
K	0°(min.), 3.5°(typ.), 7°(max.)					

OUTLINE AND MECHANICAL DATA

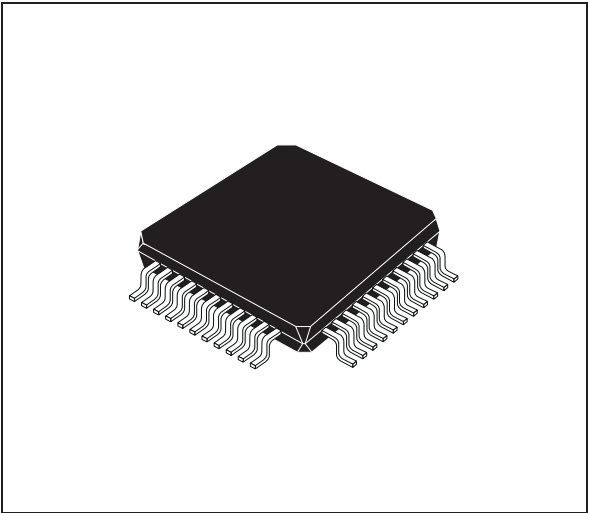

TQFP44 (10 x 10)

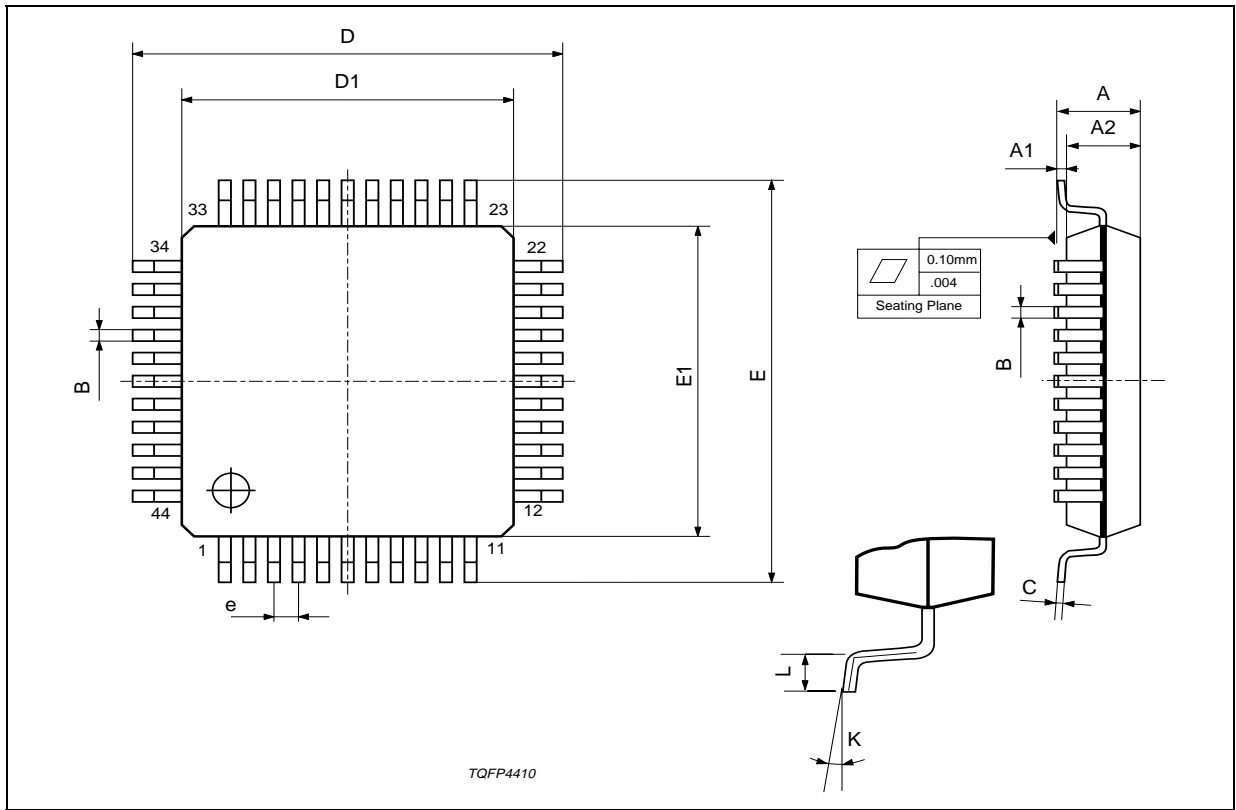

Information furnished is believed to be accurate and reliable. However, STMicroelectronics assumes no responsibility for the consequences of use of such information nor for any infringement of patents or other rights of third parties which may result from its use. No license is granted by implication or otherwise under any patent or patent rights of STMicroelectronics. Specifications mentioned in this publication are subject to change without notice. This publication supersedes and replaces all information previously supplied. STMicroelectronics products are not authorized for use as critical components in life support devices or systems without express written approval of STMicroelectronics.

The ST logo is a registered trademark of STMicroelectronics
© 2002 STMicroelectronics - All Rights Reserved

STMicroelectronics GROUP OF COMPANIES

Australia - Brazil - Canada - China - Finland - France - Germany - Hong Kong - India - Israel - Italy - Japan - Malaysia - Malta - Morocco -
Singapore - Spain - Sweden - Switzerland - United Kingdom - United States.

<http://www.st.com>