



# L6911C

## 5 BIT PROGRAMMABLE STEP DOWN CONTROLLER WITH SYNCHRONOUS RECTIFICATION

- OPERATING SUPPLY IC VOLTAGE FROM 5V TO 12V BUSES
- UP TO 1.3A GATE CURRENT CAPABILITY
- TTL-COMPATIBLE 5 BIT PROGRAMMABLE OUTPUT COMPLIANT WITH VRM 8.4 :  
1.3V TO 2.05V WITH 0.05V BINARY STEPS  
2.1V TO 3.5V WITH 0.1V BINARY STEPS
- VOLTAGE MODE PWM CONTROL
- EXCELLENT OUTPUT ACCURACY:  $\pm 1\%$  OVER LINE AND TEMPERATURE VARIATIONS
- VERY FAST LOAD TRANSIENT RESPONSE: FROM 0% TO 100% DUTY CYCLE
- POWER GOOD OUTPUT VOLTAGE
- OVERVOLTAGE PROTECTION AND MONITOR
- OVERCURRENT PROTECTION REALIZED USING THE UPPER MOSFET'S  $R_{dsON}$
- 200KHz INTERNAL OSCILLATOR
- OSCILLATOR EXTERNALLY ADJUSTABLE FROM 50KHz TO 1MHz
- SOFT START AND INHIBIT FUNCTIONS

### APPLICATIONS

- POWER SUPPLY FOR ADVANCED MICROPROCESSOR CORE
- DISTRIBUTED POWER SUPPLY
- HIGH POWER DC-DC REGULATORS

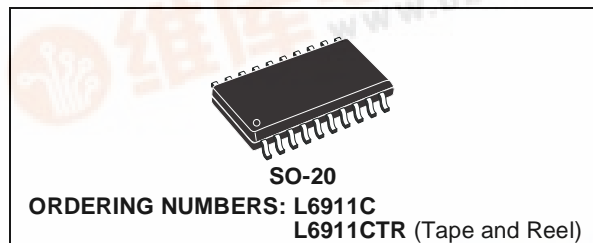

### DESCRIPTION

The device is a power supply controller specifically designed to provide a high performance DC/DC conversion for high current microprocessors. A precise 5-bit digital to analog converter (DAC) allows adjusting the output voltage from 1.30V to 2.05V with 50mV binary steps and from 2.10V to 3.50V with 100mV binary steps.

The high precision internal reference assures the selected output voltage to be within  $\pm 1\%$ . The high peak current gate drive affords to have fast switching to the external power mos providing low switching losses.

The device assures a fast protection against load overcurrent and load overvoltage. An external SCR is triggered to crowbar the input supply in case of hard over-voltage. An internal crowbar is also provided turning on the low side mosfet as long as the over-voltage is detected. In case of over-current detection, the soft start capacitor is discharged and the system works in HICCUP mode.

### BLOCK DIAGRAM

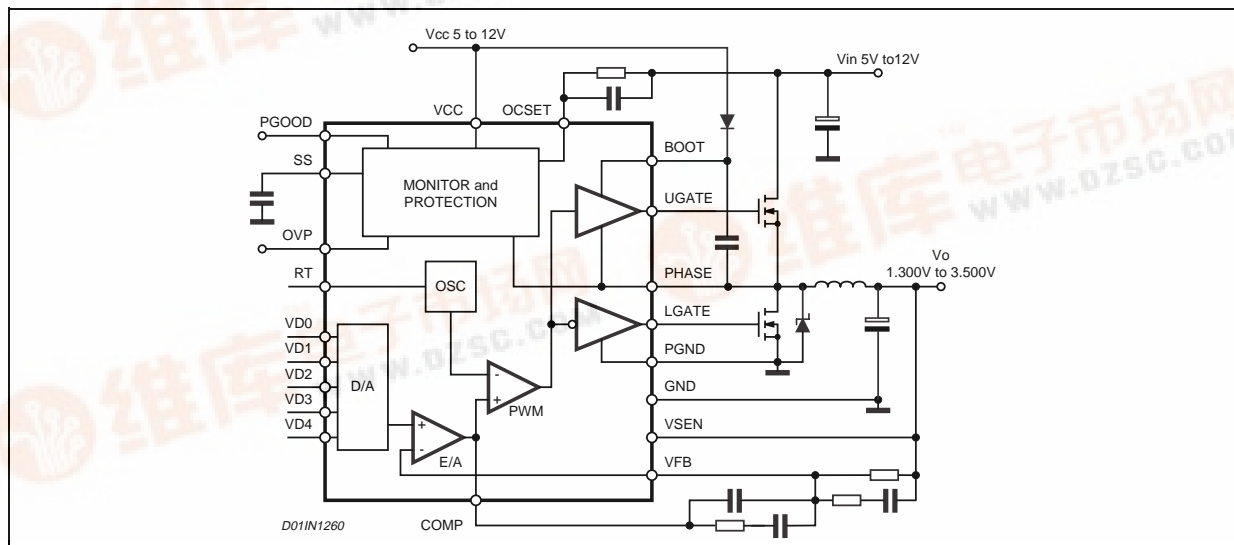

## L6911C

### ABSOLUTE MAXIMUM RATINGS

| Symbol                                 | Parameter                       | Value                        | Unit |
|--|---------------------------------|------------------------------|------|
| V <sub>CC</sub>                        | V <sub>CC</sub> to GND, PGND    | 15                           | V    |
| V <sub>BOOT</sub> -V <sub>PHASE</sub>  | Boot Voltage                    | 15                           | V    |
| V <sub>HGATE</sub> -V <sub>PHASE</sub> |                                 | 15                           | V    |
|  | OCSET, LGATE, PHASE             | -0.3 to V <sub>CC</sub> +0.3 | V    |
|  | RT, SS, FB, PGOOD, VSEN, VID0-4 | 7                            | V    |
|  | OVP, COMP                       | 6.5                          | V    |

### THERMAL DATA

| Symbol                | Parameter                              | Value      | Unit |
|-----------------------|--|------------|------|
| R <sub>th j-amb</sub> | Thermal Resistance Junction to Ambient | 110        | °C/W |
| T <sub>j</sub>        | Maximum junction temperature           | 150        | °C   |
| T <sub>stg</sub>      | Storage temperature range              | -40 to 150 | °C   |
| T <sub>J</sub>        | Junction temperature range             | 0 to 125   | °C   |

### PIN CONNECTION (Top view)

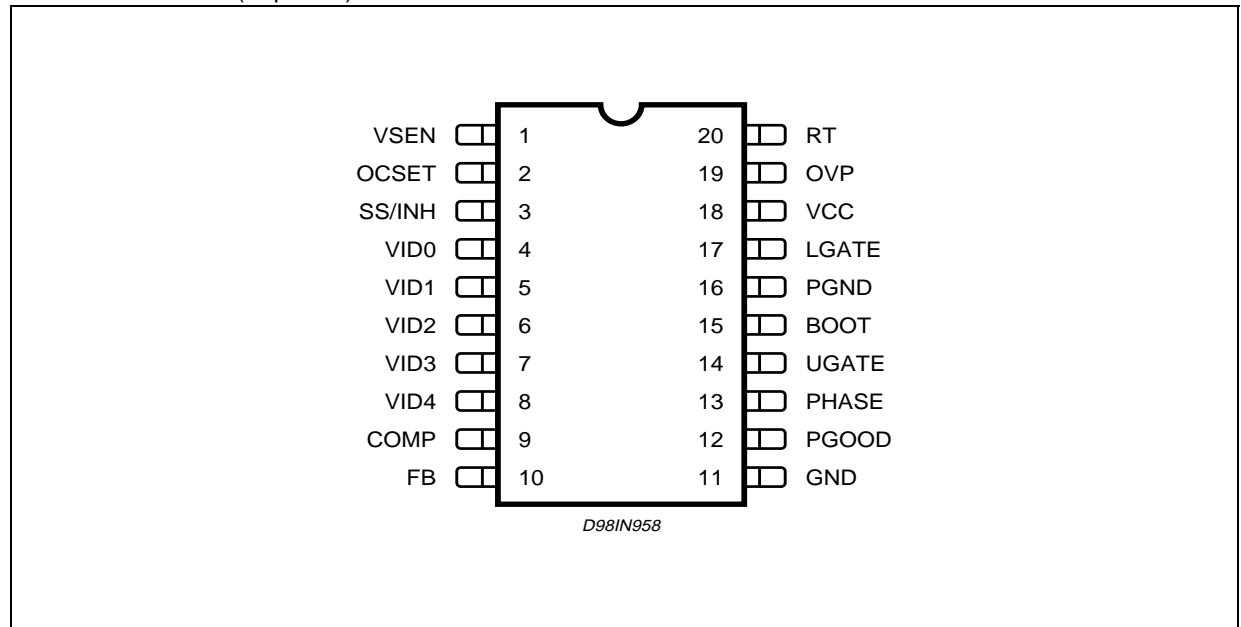

## PIN FUNCTION

| Pin Num. | Name     | Description   |
|----------|----------|---|
| 1        | VSEN     | Connected to the output voltage is able to manage over-voltage conditions and the PGOOD signal.   |
| 2        | OCSET    | A resistor connected from this pin and the upper Mos Drain sets the current limit protection. The internal 200µA current generator sinks a current from the drain through the external resistor. The Over-Current threshold is due to the following equation:<br>$I_P = \frac{I_{OCSET} \cdot R_{OCSET}}{R_{DSon}}$   |
| 3        | SS/INH   | The soft start time is programmed connecting an external capacitor from this pin and GND. The internal current generator forces through the capacitor 10µA. This pin can be used to disable the device forcing a voltage lower than 0.4V  |
| 4 - 8    | VID0 - 4 | Voltage Identification Code pins. These input are internally pulled-up and TTL compatible. They are used to program the output voltage as specified in Table 1 and to set the overvoltage and power good thresholds. Connect to GND to program a '0' while leave floating to program a '1'.   |
| 9        | COMP     | This pin is connected to the error amplifier output and is used to compensate the voltage control feedback loop.  |
| 10       | FB       | This pin is connected to the error amplifier inverting input and is used to compensate the voltage control feedback loop.   |
| 11       | GND      | All the internal references are referred to this pin. Connect it to the PCB signal ground.  |
| 12       | PGOOD    | This pin is an open collector output and is pulled low if the output voltage is not within the above specified thresholds. If not used may be left floating.  |
| 13       | PHASE    | This pin is connected to the source of the upper mosfet and provides the return path for the high side driver. This pin monitors the drop across the upper mosfet for the current limit   |
| 14       | UGATE    | High side gate driver output.   |
| 15       | BOOT     | Bootstrap capacitor pin. Through this pin is supplied the high side driver and the upper mosfet. Connect through a capacitor to the PHASE pin and through a diode to Vcc (cathode vs. boot).  |
| 16       | PGND     | Power ground pin. This pin has to be connected closely to the low side mosfet source in order to reduce the noise injection into the device   |
| 17       | LGATE    | This pin is the lower mosfet gate driver output   |
| 18       | VCC      | Device supply voltage. The operative nominal supply voltage ranges from 5 to 12V. DO NOT CONNECT V <sub>IN</sub> TO A VOLTAGE GREATER THAN V <sub>CC</sub> .  |
| 19       | OVP      | Over voltage protection. If the output voltage reaches the 17% above the programmed voltage this pin is driven high and can be used to drive an external SCR that crowbar the supply voltage. If not used, it may be left floating.   |
| 20       | RT       | Oscillator switching frequency pin. Connecting an external resistor from this pin to GND, the external frequency is increased according to the equation:<br>$f_S = 200\text{kHz} + \frac{4.94 \cdot 10^6}{R_T(\text{k}\Omega)}$ <p>Connecting a resistor from this pin to Vcc (12V), the switching frequency is reduced according to the equation:<br/> <math display="block">f_S = 200\text{kHz} - \frac{4.306 \cdot 10^7}{R_T(\text{k}\Omega)}</math> <p>If the pin is not connected, the switching frequency is 200KHz.<br/> The voltage at this pin is fixed at 1.23V (typ). Forcing a 50µA current into this pin, the built in oscillator stops to switch.</p></p> |

## L6911C

### ELECTRICAL CHARACTERISTICS ( $V_{CC} = 12V$ , $T_{amb} = 25^{\circ}C$ unless otherwise specified)

| Symbol                               | Parameter                                    | Test Condition  | Min. | Typ. | Max. | Unit |
|--------------------------------------|--|---|------|------|------|------|
| <b>V<sub>CC</sub> SUPPLY CURRENT</b> |  |   |      |      |      |      |
| I <sub>CC</sub>                      | V <sub>CC</sub> Supply current               | UGATE and LGATE open  |      | 5    |      | mA   |
| <b>POWER-ON</b>                      |  |   |      |      |      |      |
|                                      | Turn-On V <sub>CC</sub> threshold            | VOCSET=4.5V   |      |      | 4.6  | V    |
|                                      | Turn-Off V <sub>CC</sub> threshold           | VOCSET=4.5V   | 3.6  |      |      | V    |
|                                      | Rising VOCSET threshold                      |   |      | 1.24 |      | V    |
| I <sub>SS</sub>                      | Soft start Current                           |   |      | 10   |      | μA   |
| <b>OSCILLATOR</b>                    |  |   |      |      |      |      |
|                                      | Free running frequency                       | R <sub>T</sub> = OPEN   | 180  | 200  | 220  | KHz  |
|                                      | Total Variation                              | 6 KΩ < RT to GND < 200 KΩ   | -15  |      | 15   | %    |
| ΔV <sub>osc</sub>                    | Ramp amplitude                               | R <sub>T</sub> = OPEN   |      | 1.9  |      | Vp-p |
| <b>REFERENCE AND DAC</b>             |  |   |      |      |      |      |
|                                      | DACOUT Voltage Accuracy                      | VID0, VID1, VID2, VID3, VID4 see Table1; T <sub>amb</sub> = 0 to 70°C                     | -1   |      | 1    | %    |
|                                      | VID Pull-Up voltage                          |   |      | 4    |      | V    |
| <b>ERROR AMPLIFIER</b>               |  |   |      |      |      |      |
|                                      | DC Gain                                      |   |      | 88   |      | dB   |
| GBWP                                 | Gain-Bandwidth Product                       |   |      | 10   |      | MHz  |
| SR                                   | Slew-Rate                                    | COMP=10pF   |      | 10   |      | V/μS |
| <b>GATE DRIVERS</b>                  |  |   |      |      |      |      |
| I <sub>UGATE</sub>                   | High Side Source Current                     | V <sub>BOOT</sub> - V <sub>PHASE</sub> =12V, V <sub>UGATE</sub> - V <sub>PHASE</sub> = 6V | 1    | 1.3  |      | A    |
| R <sub>UGATE</sub>                   | High Side Sink Resistance                    | V <sub>BOOT</sub> -V <sub>PHASE</sub> =12V, I <sub>UGATE</sub> = 300mA                    |      | 2    | 4    | Ω    |
| I <sub>LGATE</sub>                   | Low Side Source Current                      | V <sub>CC</sub> =12V, V <sub>LGATE</sub> = 6V   | 0.9  | 1.1  |      | A    |
| R <sub>LGATE</sub>                   | Low Side Sink Resistance                     | V <sub>CC</sub> =12V, I <sub>LGATE</sub> = 300mA  |      | 1.5  | 3    | Ω    |
|                                      | Output Driver Dead Time                      | PHASE connected to GND  |      | 120  |      | ns   |
| <b>PROTECTIONS</b>                   |  |   |      |      |      |      |
|                                      | Over Voltage Trip (V <sub>SEN</sub> /DACOUT) | V <sub>SEN</sub> Rising   |      | 117  | 120  | %    |
| I <sub>OCSET</sub>                   | OCSET Current Source                         | VOCSET = 4.5V   | 170  | 200  | 230  | μA   |
| I <sub>OVP</sub>                     | OVP Sourcing Current                         | V <sub>SEN</sub> > OVP Trip, V <sub>OVP</sub> =0V   | 60   |      |      | mA   |
| <b>POWER GOOD</b>                    |  |   |      |      |      |      |
|                                      | Upper Threshold (V <sub>SEN</sub> /DACOUT)   | V <sub>SEN</sub> Rising   | 110  | 112  | 114  | %    |
|                                      | Lower Threshold (V <sub>SEN</sub> /DACOUT)   | V <sub>SEN</sub> Falling  | 86   | 88   | 90   | %    |
|                                      | Hysteresis (V <sub>SEN</sub> /DACOUT)        | Upper and Lower threshold   |      | 2    |      | %    |
| V <sub>PGOOD</sub>                   | PGOOD Voltage Low                            | I <sub>PGOOD</sub> = -5mA   |      | 0.5  |      | V    |

Table 1. VID Settings

| VID4 | VID3 | VID2 | VID1 | VID0 | Output Voltage (V) | VID4 | VID3 | VID2 | VID1 | VID0 | Output Voltage (V) |
|------|------|------|------|------|--------------------|------|------|------|------|------|--------------------|
| 0    | 1    | 1    | 1    | 1    | 1.30               | 1    | 1    | 1    | 1    | 1    | Output Off         |
| 0    | 1    | 1    | 1    | 0    | 1.35               | 1    | 1    | 1    | 1    | 0    | 2.1                |
| 0    | 1    | 1    | 0    | 1    | 1.40               | 1    | 1    | 1    | 0    | 1    | 2.2                |
| 0    | 1    | 1    | 0    | 0    | 1.45               | 1    | 1    | 1    | 0    | 0    | 2.3                |
| 0    | 1    | 0    | 1    | 1    | 1.50               | 1    | 1    | 0    | 1    | 1    | 2.4                |
| 0    | 1    | 0    | 1    | 0    | 1.55               | 1    | 1    | 0    | 1    | 0    | 2.5                |
| 0    | 1    | 0    | 0    | 1    | 1.60               | 1    | 1    | 0    | 0    | 1    | 2.6                |
| 0    | 1    | 0    | 0    | 0    | 1.65               | 1    | 1    | 0    | 0    | 0    | 2.7                |
| 0    | 0    | 1    | 1    | 1    | 1.70               | 1    | 0    | 1    | 1    | 1    | 2.8                |
| 0    | 0    | 1    | 1    | 0    | 1.75               | 1    | 0    | 1    | 1    | 0    | 2.9                |
| 0    | 0    | 1    | 0    | 1    | 1.80               | 1    | 0    | 1    | 0    | 1    | 3.0                |
| 0    | 0    | 1    | 0    | 0    | 1.85               | 1    | 0    | 1    | 0    | 0    | 3.1                |
| 0    | 0    | 0    | 1    | 1    | 1.90               | 1    | 0    | 0    | 1    | 1    | 3.2                |
| 0    | 0    | 0    | 1    | 0    | 1.95               | 1    | 0    | 0    | 1    | 0    | 3.3                |
| 0    | 0    | 0    | 0    | 1    | 2.00               | 1    | 0    | 0    | 0    | 1    | 3.4                |
| 0    | 0    | 0    | 0    | 0    | 2.05               | 1    | 0    | 0    | 0    | 0    | 3.5                |

### Device Description

The device is an integrated circuit realized in BCD technology. It provides complete control logic and protections for a high performance step-down DC-DC converter optimized for microprocessor power supply. It is designed to drive N-Channel Mosfets in a synchronous-rectified buck topology. The device works properly with V<sub>CC</sub> ranging from 5V to 12V and regulates the output voltage starting from a 1.26V power stage supply voltage (V<sub>in</sub>). The output voltage of the converter can be precisely regulated, programming the VID pins, from 1.3V to 2.05V with 50mV binary steps and from 2.1V to 3.5V with 100mV binary steps, with a maximum tolerance of ±1% over temperature and line voltage variations. The device provides voltage-mode control with fast transient response. It includes a 200kHz free-running oscillator that is adjustable from 50kHz to 1MHz. The error amplifier features a 15MHz gain-bandwidth product and 10V/μsec slew rate which permits high converter bandwidth for fast transient performance. The resulting PWM duty cycle ranges from 0% to 100%. The device protects against over-current conditions entering in HICCUP mode. The device monitors the current by using the r<sub>DS(ON)</sub> of the upper MOSFET which eliminates the need for a current sensing resistor.

The device is available in SO20 package.

### Oscillator

The switching frequency is internally fixed to 200kHz. The internal oscillator generates the triangular waveform for the PWM charging and discharging with a constant current an internal capacitor. The current delivered to the oscillator is typically 50μA (F<sub>sw</sub>=200KHz) and may be varied using an external resistor (R<sub>T</sub>) connected between RT pin and GND or VCC. Since the RT pin is maintained at fixed voltage (typ. 1.235V), the frequency is varied proportionally to the current sunk (forced) from (into) the pin.

In particular connecting it to GND the frequency is increased (current is sunk from the pin), according to the following relationship:

$$f_s = 200\text{kHz} + \frac{4.94 \cdot 10^6}{R_T(\text{k}\Omega)}$$

Connecting RT to VCC=12V or to VCC=5V the frequency is reduced (current is forced into the pin), according to the following relationships:

$$f_S = 200\text{kHz} + \frac{4.306 \cdot 10^7}{R_T(\text{k}\Omega)} \quad V_{CC} = 12\text{V}$$

$$f_S = 200\text{kHz} + \frac{15 \cdot 10^7}{R_T(\text{k}\Omega)} \quad V_{CC} = 5\text{V}$$

Switching frequency variations vs.  $R_T$  are reported in Fig.1.

Note that forcing a  $50\mu\text{A}$  current into this pin, the device stops switching because no current is delivered to the oscillator.

Figure 1.

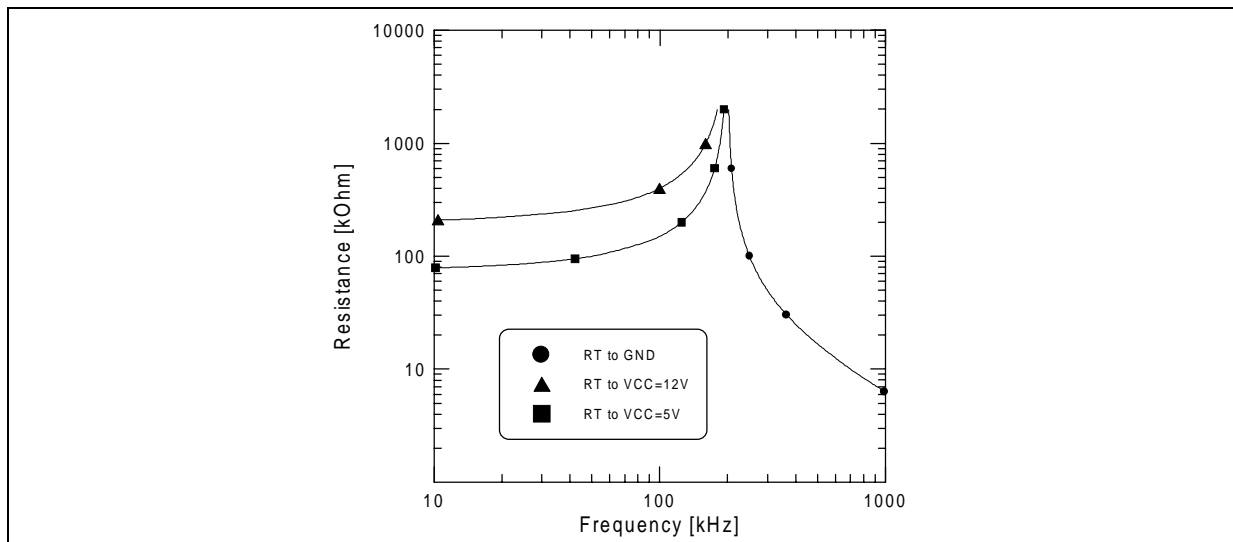

### Digital to Analog Converter

The built-in digital to analog converter allows the adjustment of the output voltage from 1.30V to 2.05V with 50mV binary steps and from 2.10V to 3.50V with 100mV binary steps as shown in the previous table 1. The internal reference is trimmed to ensure the precision of 1%.

The internal reference voltage for the regulation is programmed by the voltage identification (VID) pins. These are TTL compatible inputs of an internal DAC that is realized by means of a series of resistors providing a partition of the internal voltage reference. The VID code drives a multiplexer that selects a voltage on a precise point of the divider. The DAC output is delivered to an amplifier obtaining the  $V_{\text{PROG}}$  voltage reference (i.e. the set-point of the error amplifier). Internal pull-ups are provided (realized with a  $5\mu\text{A}$  current generator); in this way, to program a logic "1" it is enough to leave the pin floating, while to program a logic "0" it is enough to short the pin to GND.

The voltage identification (VID) pin configuration also sets the power-good thresholds (PGOOD) and the over-voltage protection (OVP) thresholds.

The VID code "11111" disable the device (as a short on the SS pin) and no output voltage is regulated.

### Soft Start and Inhibit

At start-up a ramp is generated charging the external capacitor  $C_{\text{SS}}$  by means of a  $10\mu\text{A}$  constant current, as shown in figure 1.

When the voltage across the soft start capacitor ( $V_{\text{SS}}$ ) reaches 0.5V the lower power MOS is turned on to dis-

charge the output capacitor. As  $V_{SS}$  reaches 1V (i.e. the oscillator triangular wave inferior limit) also the upper MOS begins to switch and the output voltage starts to increase.

The  $V_{SS}$  growing voltage initially clamps the output of the error amplifier, and consequently  $V_{OUT}$  linearly increases, as shown in figure 2. In this phase the system works in open loop. When  $V_{SS}$  is equal to  $V_{COMP}$  the clamp on the output of the error amplifier is released. In any case another clamp on the input of the error amplifier remains active, allowing to  $V_{OUT}$  to grow with a lower slope (i.e. the slope of the  $V_{SS}$  voltage, see figure 2). In this second phase the system works in closed loop with a growing reference. As the output voltage reaches the desired value  $V_{PROG}$ , also the clamp on the error amplifier input is removed, and the soft start finishes.  $V_{SS}$  increases until a maximum value of about 4V.

The Soft-Start will not take place, and the relative pin is internally shorted to GND, if both VCC and OCSET pins are not above their own turn-on thresholds. During normal operation, if any under-voltage is detected on one of the two supplies, the SS pin is internally shorted to GND and so the SS capacitor is rapidly discharged.

The device goes in INHIBIT state forcing SS pin below 0.4V. In this condition both external MOSFETS are kept off.

**Figure 2. Soft Start**

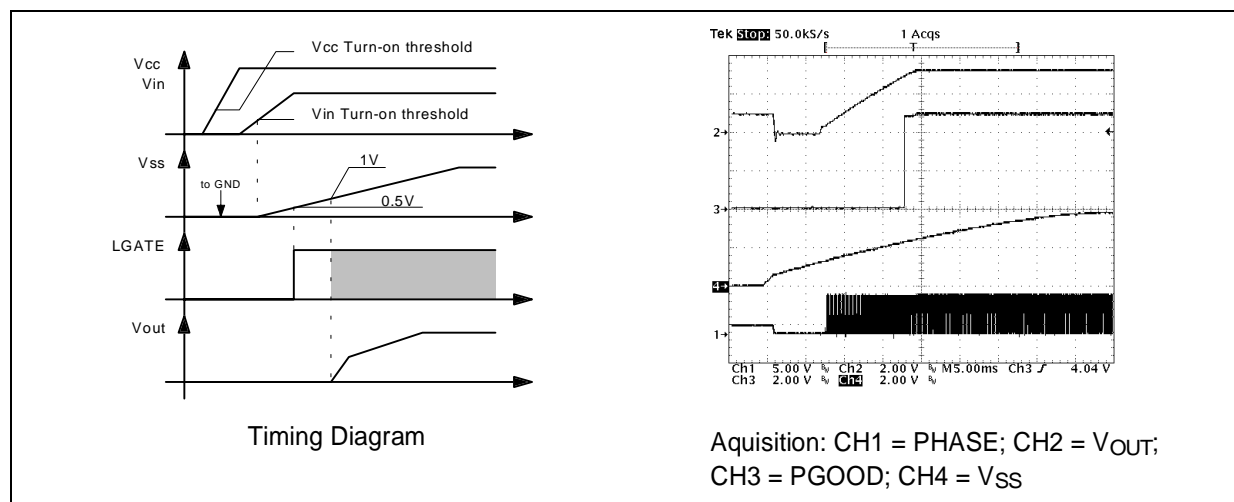

## Driver Section

The driver capability on the high and low side drivers allows using different types of power MOS (also multiple MOS to reduce the  $R_{DS(ON)}$ ), maintaining fast switching transition.

The low-side mos driver is supplied directly by  $V_{cc}$  while the high-side driver is supplied by the BOOT pin.

Adaptative dead time control is implemented to prevent cross-conduction and allow to use several kinds of mosfets. The upper mos turn-on is avoided if the lower gate is over about 200mV while the lower mos turn-on is avoided if the PHASE pin is over about 500mV. The upper mos is in any case turned-on after 200ns from the low side turn-off.

The peak current is shown for both the upper (fig. 3) and the lower (fig. 4) driver at 5V and 12V. A 4nF capacitive load has been used in these measurements.

For the lower driver, the source peak current is 1.1A @  $V_{cc}=12V$  and 500mA @  $V_{cc}=5V$ , and the sink peak current is 1.3A @  $V_{cc}=12V$  and 500mA @  $V_{cc}=5V$ .

Similarly, for the upper driver, the source peak current is 1.3A @  $V_{boot-V_{phase}}=12V$  and 600mA @  $V_{boot-V_{phase}}=5V$ , and the sink peak current is 1.3A @  $V_{boot-V_{phase}}=12V$  and 550mA @  $V_{boot-V_{phase}}=5V$ .

Figure 3. High Side driver peak current. Vboot-Vphase=12V (left) Vboot-Vphase=5V (right)

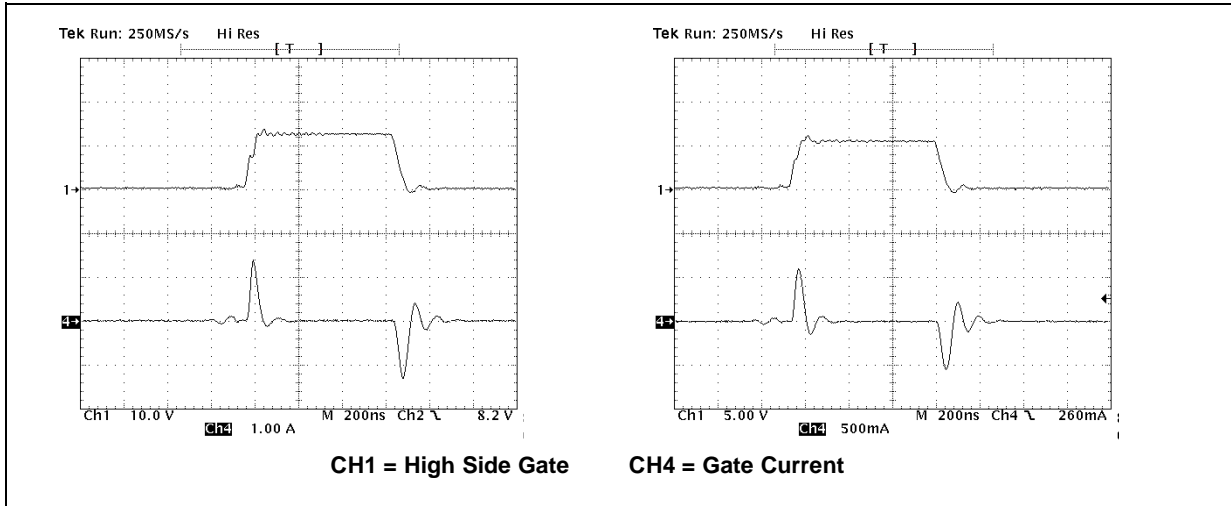
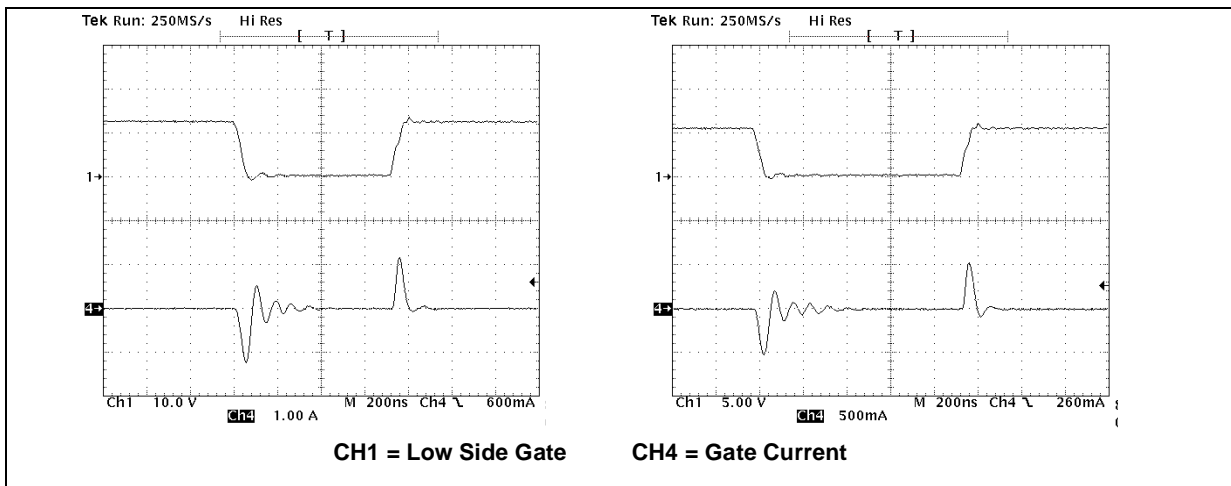

Figure 4. Low Side driver peak current. Vcc=12V (left) Vcc=5V (right)



**Monitoring and Protections**

The output voltage is monitored by means of pin 1 (VSEN). If it is not within ±12% (typ.) of the programmed value, the powergood output is forced low.

The device provides overvoltage protection, when the output voltage reaches a value 17% (typ.) greater than the nominal one. If the output voltage exceeds this threshold, the OVP pin is forced high, triggering an external SCR to shut the supply (VIN) down, and also the lower driver is turned on as long as the over-voltage is detected.

To perform the overcurrent protection the device compares the drop across the high side MOS, due to the RDSON, with the voltage across the external resistor (ROCS) connected between the OCSET pin and drain of the upper MOS. Thus the overcurrent threshold (IP) can be calculated with the following relationship:

$$I_P = \frac{I_{OCS} \cdot R_{OCS}}{R_{DSON}}$$

Where the typical value of IOCS is 200µA. To calculate the ROCS value it must be considered the maximum RDSON (also the variation with temperature) and the minimum value of IOCS. To avoid undesirable trigger of



overcurrent protection this relationship must be satisfied:

$$I_P \geq I_{OUTMAX} + \frac{\Delta I}{2} = I_{PEAK}$$

Where  $\Delta I$  is the inductance ripple current and  $I_{OUTMAX}$  is the maximum output current.

In case of output short circuit the soft start capacitor is discharged with constant current (10 $\mu$ A typ.) and when the SS pin reaches 0.5V the soft start phase is restarted. During the soft start the over-current protection is always active and if such kind of event occurs, the device turns off both mosfets, and the SS capacitor is discharged again (after reaching the upper threshold of about 4V). The system is now working in HICCUP mode, as shown in figure 5a. After removing the cause of the over-current, the device restart working normally without power supplies turn off and on.

**Figure 5.**

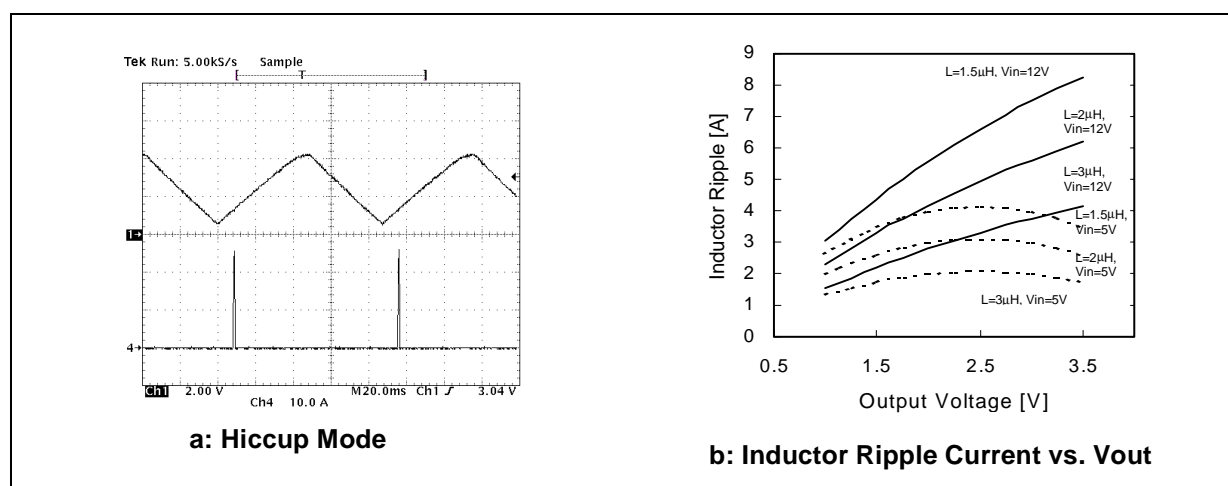

### Inductor design

The inductance value is defined by a compromise between the transient response time, the efficiency, the cost and the size. The inductor has to be calculated to sustain the output and the input voltage variation to maintain the ripple current  $\Delta I_L$  between 20% and 30% of the maximum output current. The inductance value can be calculated with this relationship:

$$L = \frac{V_{IN} - V_{OUT}}{f_S \cdot \Delta I_L} \cdot \frac{V_{OUT}}{V_{IN}}$$

Where  $f_{SW}$  is the switching frequency,  $V_{IN}$  is the input voltage and  $V_{OUT}$  is the output voltage. Figure 5b shows the ripple current vs. the output voltage for different values of the inductor, with  $V_{IN} = 5V$  and  $V_{IN} = 12V$ .

Increasing the value of the inductance reduces the ripple current but, at the same time, reduces the converter response time to a load transient. If the compensation network is well designed, the device is able to open or close the duty cycle up to 100% or down to 0%. The response time is now the time required by the inductor to change its current from initial to final value. Since the inductor has not finished its charging time, the output current is supplied by the output capacitors. Minimizing the response time can minimize the output capacitance required.

The response time to a load transient is different for the application or the removal of the load: if during the application of the load the inductor is charged by a voltage equal to the difference between the input and the output voltage, during the removal it is discharged only by the output voltage. The following expressions give approximate response time for  $\Delta I$  load transient in case of enough fast compensation network response:

$$t_{\text{application}} = \frac{L \cdot \Delta I}{V_{\text{IN}} - V_{\text{OUT}}} \quad t_{\text{removal}} = \frac{L \cdot \Delta I}{V_{\text{OUT}}}$$

The worst condition depends on the input voltage available and the output voltage selected. Anyway the worst case is the response time after removal of the load with the minimum output voltage programmed and the maximum input voltage available.

### Output Capacitor

Since the microprocessors require a current variation beyond 10A doing load transients, with a slope in the range of tenth A/ $\mu$ sec, the output capacitor is a basic component for the fast response of the power supply. In fact for first few microseconds they supply the current to the load. The controller recognizes immediately the load transient and sets the duty cycle at 100%, but the current slope is limited by the inductor value.

The output voltage has a first drop due to the current variation inside the capacitor (neglecting the effect of the ESL):

$$\Delta V_{\text{OUT}} = \Delta I_{\text{OUT}} \cdot \text{ESR}$$

A minimum capacitor value is required to sustain the current during the load transient without discharge it. The voltage drop due to the output capacitor discharge is given by the following equation:

$$\Delta V_{\text{OUT}} = \frac{\Delta I_{\text{OUT}}^2 \cdot L}{2 \cdot C_{\text{OUT}} \cdot (V_{\text{INMIN}} \cdot D_{\text{MAX}} - V_{\text{OUT}})}$$

Where  $D_{\text{MAX}}$  is the maximum duty cycle value that is 100%. The lower is the ESR, the lower is the output drop during load transient and the lower is the output voltage static ripple.

### Input Capacitor

The input capacitor has to sustain the ripple current produced during the on time of the upper MOS, so it must have a low ESR to minimize the losses. The rms value of this ripple is:

$$I_{\text{rms}} = I_{\text{OUT}} \sqrt{D \cdot (1 - D)}$$

Where D is the duty cycle. The equation reaches its maximum value with  $D=0.5$ . The losses in worst case are:

$$P = \text{ESR} \cdot I_{\text{rms}}^2$$

### Compensation network design

The control loop is a voltage mode (figure 7) that uses a droop function to satisfy the requirements for a VRM module, reducing the size and the cost of the output capacitor.

This method "recovers" part of the drop due to the output capacitor ESR in the load transient, introducing a dependence of the output voltage on the load current: at light load the output voltage will be higher than the nominal level, while at high load the output voltage will be lower than the nominal value.

**Figure 6. Output transient response without (a) and with (b) the droop function**

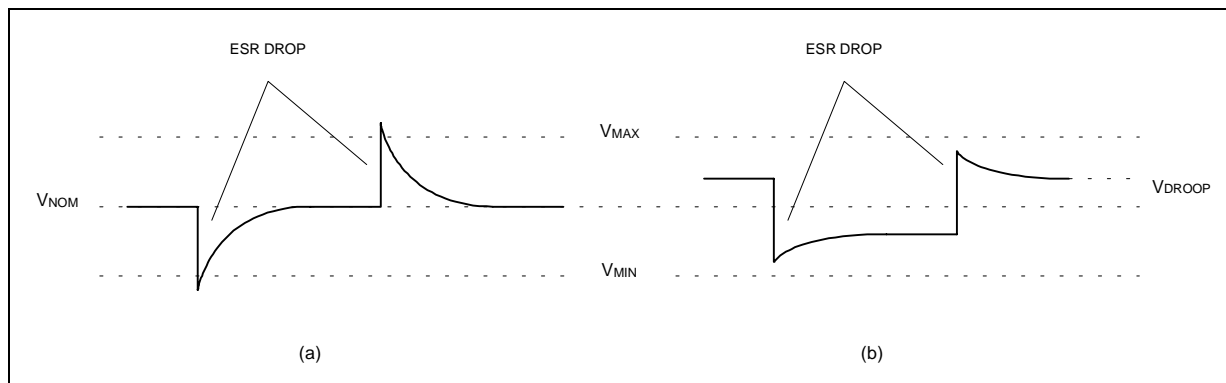

As shown in figure 6, the ESR drop is present in any case, but using the droop function the total deviation of the output voltage is minimized. In practice the droop function introduces a static error ( $V_{DROOP}$  in figure 6) proportional to the output current. Since a sense resistor is not present, the output DC current is measured by using the intrinsic resistance of the inductance (a few  $m\Omega$ ). So the low-pass filtered inductor voltage (that is the inductor current) is added to the feedback signal, implementing the droop function in a simple way. Referring to the schematic in figure 7, the static characteristic of the closed loop system is:

$$V_{OUT} = V_{PROG} + V_{PROG} \cdot \frac{R_3 + R_8 // R_9}{R_2} - \frac{R_L \cdot R_8 // R_9}{R_8} \cdot I_{OUT}$$

Where  $V_{PROG}$  is the output voltage of the digital to analog converter (i.e. the set point) and  $R_L$  is the inductance resistance. The second term of the equation allows a positive offset at zero load ( $\Delta V^+$ ); the third term introduces the droop effect ( $\Delta V_{DROOP}$ ). Note that the droop effect is equal the ESR drop if:

$$\frac{R_L \cdot R_8 // R_9}{R_8} = ESR$$

**Figure 7. Compensation network**

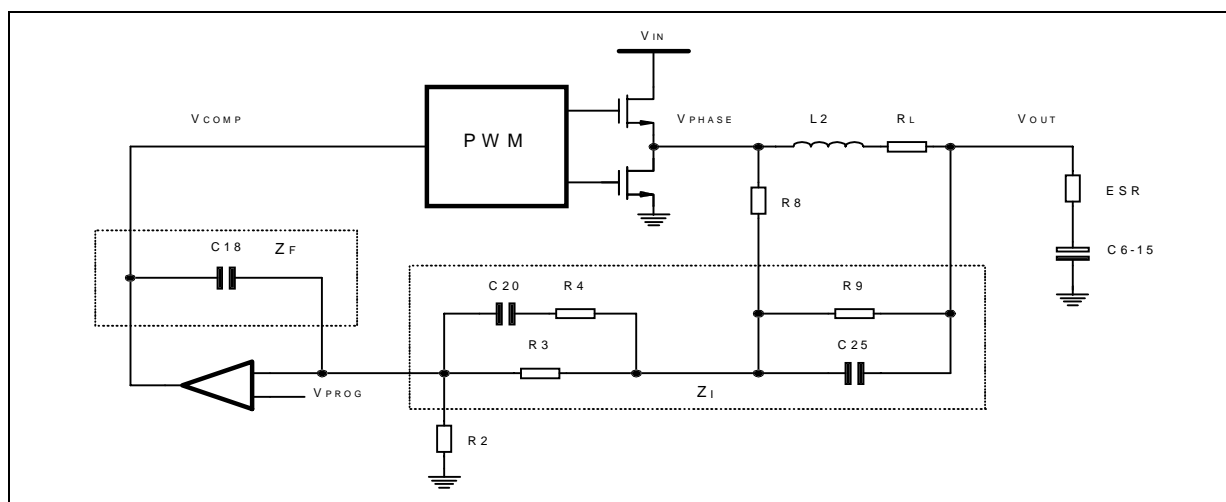

Considering the previous relationships  $R_2$ ,  $R_3$ ,  $R_8$  and  $R_9$  may be determined in order to obtain the desired droop effect as follow:

- Choose a value for  $R_2$  in the range of hundreds of  $K\Omega$  to obtain realistic values for the other components.

■ From the above equations, it results:

$$R8 = \frac{\Delta V^+ \cdot R2}{V_{PROG}} \cdot \frac{R_L \cdot I_{MAX}}{\Delta V_{DROOP}};$$

$$R9 = R8 \cdot \frac{\Delta V_{DROOP}}{R_L \cdot I_{MAX}} \cdot \frac{1}{1 + \frac{\Delta V_{DROOP}}{R_L \cdot I_{MAX}}};$$

Where  $I_{MAX}$  is the maximum output current.

■ The component R3 must be chosen in order to obtain  $R3 \ll R8/R9$  to permit these and successive simplifications.

Therefore, with the droop function the output voltage decreases as the load current increases, so the DC output impedance is equal to a resistance  $R_{OUT}$ . It is easy to verify that the output voltage deviation under load transient is minimum when the output impedance is constant with frequency.

To choose the other components of the compensation network, the transfer function of the voltage loop is considered. To simplify the analysis is supposed that  $R3 \ll R_d$ , where  $R_d = (R8/R9)$ .

Figure 8. Compensation network definition

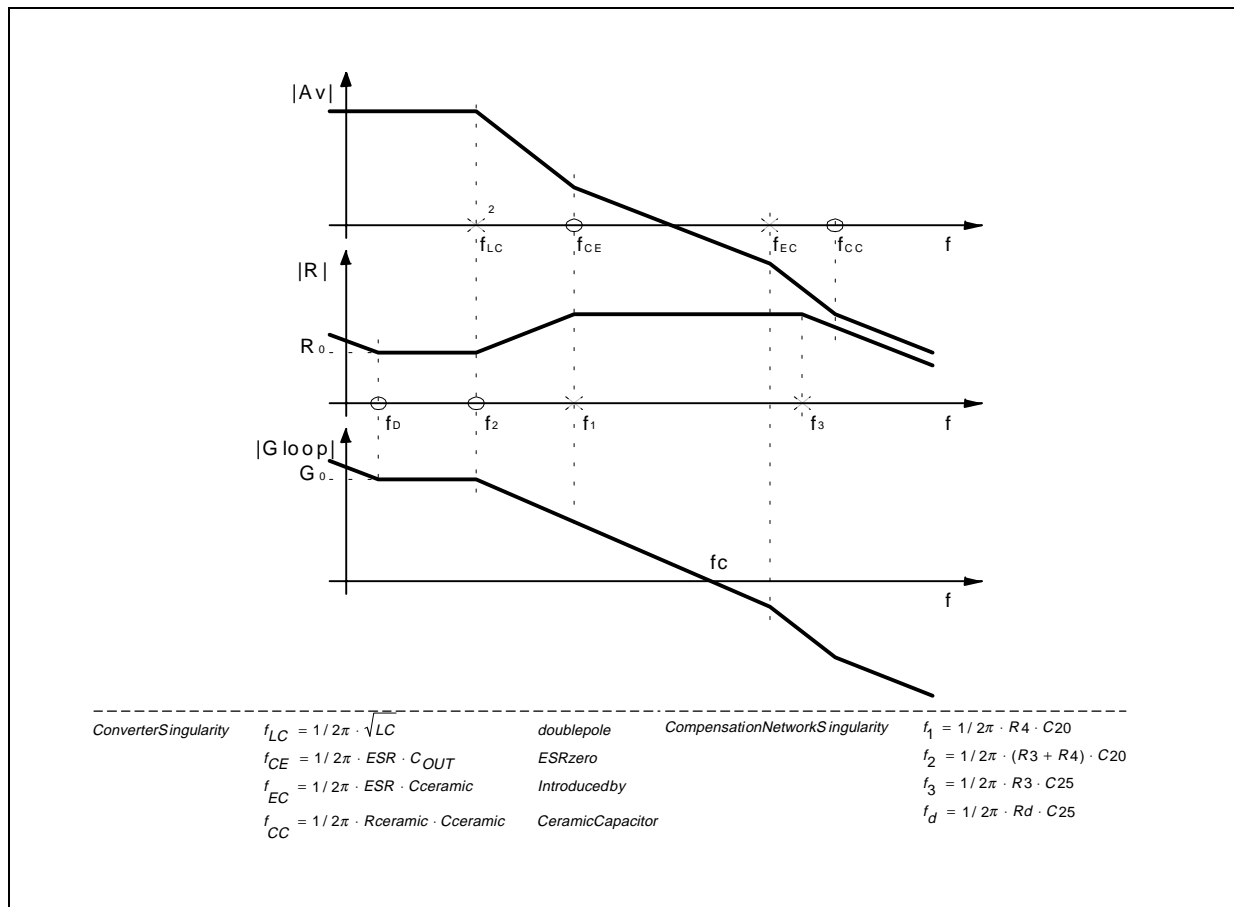

The transfer function may be evaluated neglecting the connection of R8 to PHASE because, as will see later, this connection is important only at low frequencies. So R4 is considered connected to VOUT. Under this assumption, the voltage loop has the following transfer function:

$$\text{Gloop}(s) = A_v(s) \cdot R(s) = A_v(s) \cdot \frac{Z_f(s)}{Z_i(s)} \quad \text{Where} \quad A_v(s) = \frac{V_{in}}{\Delta V_{osc}} \cdot \frac{Z_C(s)}{Z_C(s) + Z_L(s)}$$

Where  $Z_C(s)$  and  $Z_L(s)$  are the output capacitor and inductor impedance respectively.

The expression of  $Z_L(s)$  may be simplified as follow:

$$\begin{aligned} Z_L(s) &= \frac{R_d \cdot \frac{1}{s} \cdot C_{25}}{R_d + \frac{1}{s} \cdot C_{25}} + \frac{\left(R_4 + \frac{1}{s} \cdot C_{20}\right) \cdot R_3}{\left(R_4 + \frac{1}{s} \cdot C_{20}\right) + R_3} = \frac{R_d \left(1 + s \cdot (\tau_1 + \tau_d) + s^2 \cdot \frac{R_3}{R_d} \cdot \tau_1 \cdot \tau_d\right)}{(1 + s \cdot \tau_2) \cdot (1 + s \cdot \tau_d)} = \\ &= R_d \frac{\left(1 + s \frac{R_3}{R_d} \cdot \tau_d\right) \cdot (1 + s \cdot \tau_1)}{(1 + s \cdot \tau_2) \cdot (1 + s \cdot \tau_d)} \end{aligned}$$

Where:  $\tau_1 = R_4 \times C_{20}$ ,  $\tau_2 = (R_4 + R_3) \times C_{20}$  and  $\tau_d = R_d \times C_{25}$ .

The regulator transfer function became now:

$$R(s) \approx \frac{(1 + s \cdot \tau_2) \cdot (1 + s \cdot \tau_d)}{s \cdot C_{18} \cdot R_d \cdot \left(1 + s \frac{R_3}{R_d} \cdot \tau_d\right) \cdot (1 + s \cdot \tau_1)}$$

Figure 8 shows a method to select the regulator components (please note that the frequencies  $f_{EC}$  and  $f_{CC}$  corresponds to the singularities introduced by additional ceramic capacitors in parallel to the output main electrolytic capacitor).

- To obtain a flat frequency response of the output impedance, the droop time constant  $\tau_d$  has to be equal to the inductor time constant (see the note at the end of the section):

$$\tau_d = R_d \cdot C_{25} = \frac{L}{R_L} = \tau_L \quad \Rightarrow \quad C_{25} = \frac{L}{(R_L \cdot R_d)}$$

- To obtain a constant -20dB/dec  $\text{Gloop}(s)$  shape the singularity  $f_1$  and  $f_2$  are placed in proximity of  $f_{CE}$  and  $f_{LC}$  respectively. This implies that:

$$\begin{aligned} \frac{f_2}{f_1} = \frac{f_{LC}}{f_{CE}} \quad \Rightarrow \quad R_4 &= R_3 \cdot \left(\frac{f_{LC}}{f_{CE}} - 1\right) \\ f_1 = f_{CE} \quad \Rightarrow \quad C_{20} &= \frac{1}{2} \cdot \pi \cdot R_4 \cdot f_{CE} \end{aligned}$$

- To obtain a Gloop bandwidth of  $f_C$ , results:

$$G_0 \cdot f_{LC} = 1 \cdot f_C \quad \Rightarrow \quad G_0 = A_0 \cdot R_0 = \frac{V_{IN}}{\Delta V_{osc}} \cdot \frac{C_{20} // C_{25}}{C_{18}} = \frac{f_C}{f_{LC}} \quad \Rightarrow \quad C_{18} = \frac{V_{IN}}{\Delta V_{osc}} \cdot \frac{C_{20} \cdot C_{25}}{C_{20} + C_{25}} \cdot \frac{f_{LC}}{f_C}$$

**Note.**

To understand the reason of the previous assumption, the scheme in figure 9 must be considered.

In this scheme, the inductor current has been substituted by the load current, because in the frequencies range of interest for the Droop function these current are substantially the same and it was supposed that the droop network don't represent a charge for the inductor.

# L6911C

**Figure 9. Voltage regulation with droop function block scheme**

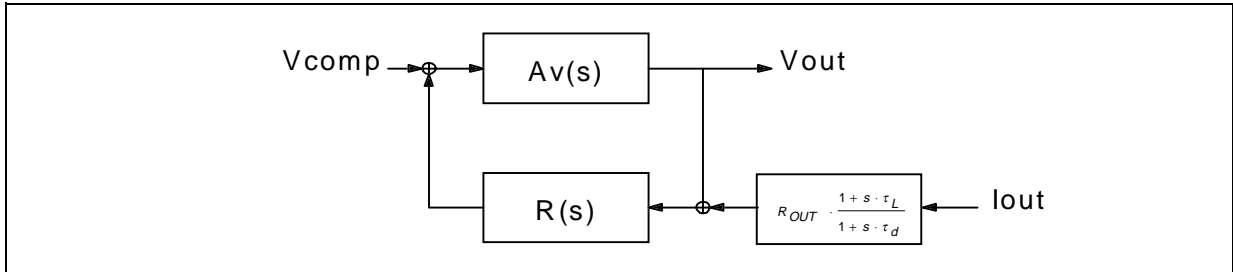

It results:

$$Z_{OUT} = \frac{V_o}{I_{LOAD}} = R_d \cdot \frac{1 + s\tau_L}{1 + s\tau_d} \cdot \frac{G_{LOOP}}{1 + G_{LOOP}} = R_{OUT} \cdot \frac{1 + s\tau_L}{1 + s\tau_d}$$

Because in the interested range  $|G_{loop}| \gg 1$ .

To obtain a flat shape, the relationship considered will naturally follow.

## Demo Board Description

The L6911C demo board shows the operation of the device in a standard VRM 8.4 application. This evaluation board allows voltage adjustability (1.3V - 3.5V) through the switches S1-S5 and high output current capability (up to 14A). The device is supplied by the 12V input rail while the power conversion starts from the 5V input rail. The device is also able to operate with a 5V supply voltage; in this case 12V input can be directly connected to the 5V power source. The four layers demo board's copper thickness is of 70µm in order to minimize conduction losses considering the high current that the circuit is able to deliver. Figure 10 shows the demo board's schematic circuit.

**Figure 10. Demo Board Schematic**

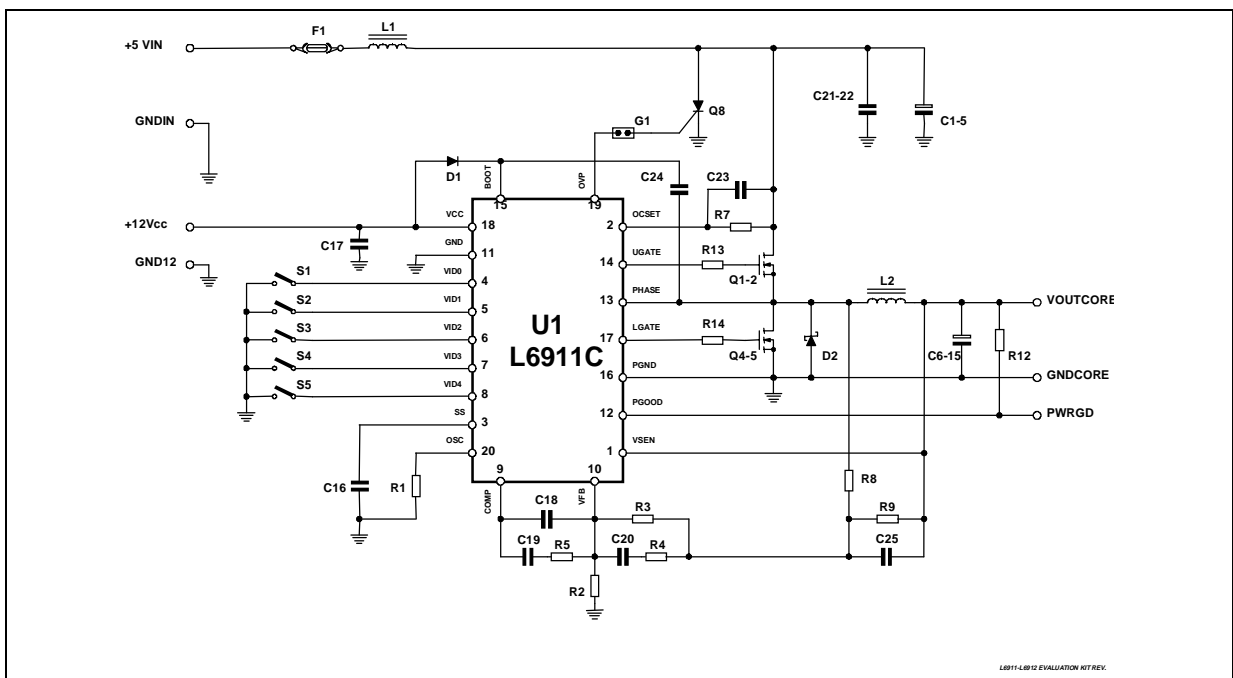

### Efficiency

Figure 11 shows the measured efficiency versus load current for different values of output voltage. The measure was done at  $V_{in}=5V$  for different values of the output voltage (2.05V and 2.75V). Two different measurements were done using IC supply voltage of 5V and 12V.

In the application two mosfets STS12NF30L (30V, 10mΩ typ @  $V_{gs}=4.5V$ ) connected in parallel are used for both the low and the high side.

The board has been layed out with the possibility to use up to three SO8 mosfets for both high and low side switch. Two D<sup>2</sup>PACK mosfets (one for each high and low side) may also be used in order to allow the maximum flexibility in meeting different requirements.

Figure 11. Efficiency vs. load

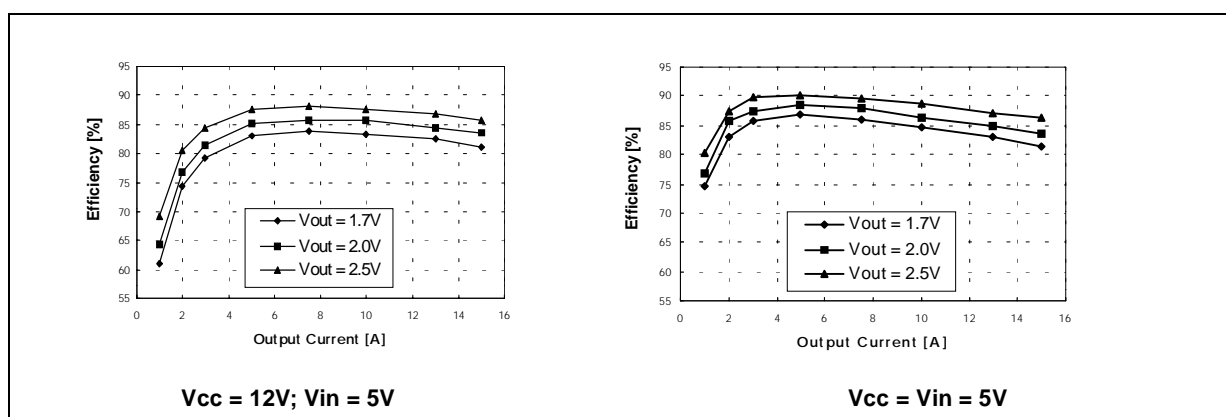

### Load Transient Response

Figure 12 shows the demo board response to a load transient application. The load transient applied changes from 0A to 14A on the output current (Channel 4). It may be observed that output voltage (Channel 1) remains within the 100mV tolerance across the regulated voltage. Figure 13 shows details about the the circuit response during current rising and falling edge; it is possible to observe that the duty cycle of the Phase signal (Channel 2) goes up to 100% or down to 0% if necessary.

Figure 12. Load Transient Response

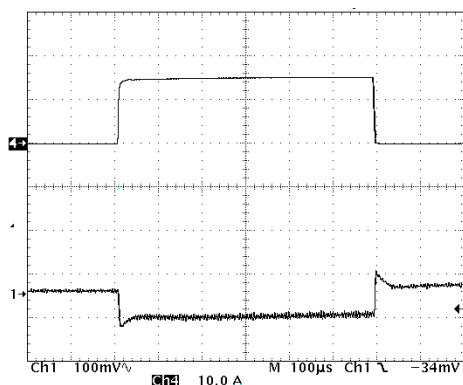
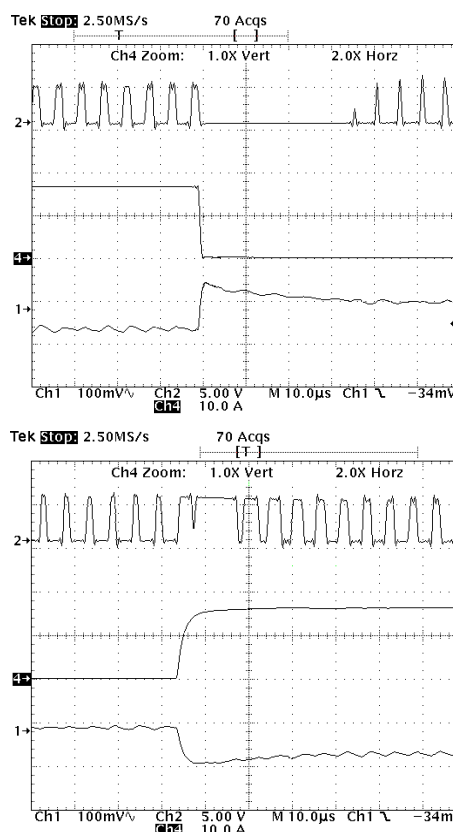

Figure 13. Load Transient Response Details



## L6911C

### Inductor selection

Since the maximum output current is equal to 14A, to have a 30% ripple (4A) in worst case a 3 $\mu$ H inductor has been chosen. So the ripple is 4.1A @ 3.5V with  $V_{IN}=12V$  and 1.7A @ 3.5V with  $V_{IN} = 5V$ . In worst case the peak is equal to 18.1A.

### Output Capacitor

In the demo ten Sanyo capacitors, model 6MV1000GX are used, with a maximum ESR equal to 69m $\Omega$ . Therefore, the resultant ESR is 69m $\Omega$ /10 = 1.9m $\Omega$ . For a load transient of 14A in worst case the drop results:

$$\Delta V_{out} = 14 \cdot 0.00069 = 96.6mV$$

The voltage drop due to the capacitor discharge during load transient, considering that the maximum duty cycle is equal to 100% results in 13mV with 2.5V of programmed output.

### Input Capacitor

For  $I_{OUT} = 14A$  and  $D = 0.5$  (worst case for input ripple current),  $I_{rms}$  is equal to 7A. Five Sanyo electrolytic capacitors 25MV330GX, with a maximum ESR equal to 69m $\Omega$ , are chosen to sustain the ripple. Therefore, the resultant ESR is equal to 69m $\Omega$ /5 = 13.8m $\Omega$ . So the losses in worst case are:

$$P = ESR \cdot I_{rms}^2 = 670mW$$

### Over-Current Protection

Substituting the demo board parameters in the relationship reported in the relative section, ( $I_{OC\ MIN} = 170\mu A$ ;  $I_P = 19A$ ;  $R_{DS\ ON\ MAX} = 9m\Omega$ ) it results that  $R_{OC\ S} = 1k\Omega$ .

### Part List

|                    |             |                         |               |
|--------------------|-------------|-------------------------|---------------|
| R2                 | 499k        | 1%                      | SMD 0805      |
| R3, R7             | 1k          | 1%                      | SMD 0805      |
| R4                 | 20          |                         | SMD 0805      |
| R5, R8             | 20k         |                         | SMD 0805      |
| R9                 | 15k         |                         | SMD 0805      |
| R12                | 1K          |                         | SMD 0805      |
| R13, R14           | 0           |                         | SMD 0805      |
| C1, C2...C5        | 330 $\mu$   | SANYO – 25MV330GX       | Radial 8x20mm |
| C6, C7...C15       | 1000 $\mu$  | SANYO – 6MV1000GX       | Radial 8x20mm |
| C16, C17, C24, C25 | 100n        | Ceramic                 | SMD 0805      |
| C18                | 2.2n        | Ceramic                 | SMD 0805      |
| C19                | 8.2n        | Ceramic                 | SMD 0805      |
| C20                | 82n         | Ceramic                 | SMD 0805      |
| C21, C22           | 1 $\mu$     | Ceramic                 | SMD 1206      |
| C23                | 1n          | Ceramic                 | SMD 0805      |
| L1                 | 1.5 $\mu$   | T44-52 Core, 7T-18AWG   |               |
| L2                 | 3 $\mu$     | T50-52B Core, 10T-16AWG |               |
| U1                 | L6911C      | STMicroelectronics      | SO20          |
| Q1, Q2...Q6        | STS12NF30L  | STMicroelectronics      | SO8           |
| D1                 | 1N4148      | STMicroelectronics      | SOT23         |
| D2                 | STPS3L25U   | STMicroelectronics      | SMB           |
| F1                 | 251015A-15° | Littlefuse              | AXIAL         |



PCB AND COMPONENTS LAYOUTS

Figure 14. PCB and Components Layouts

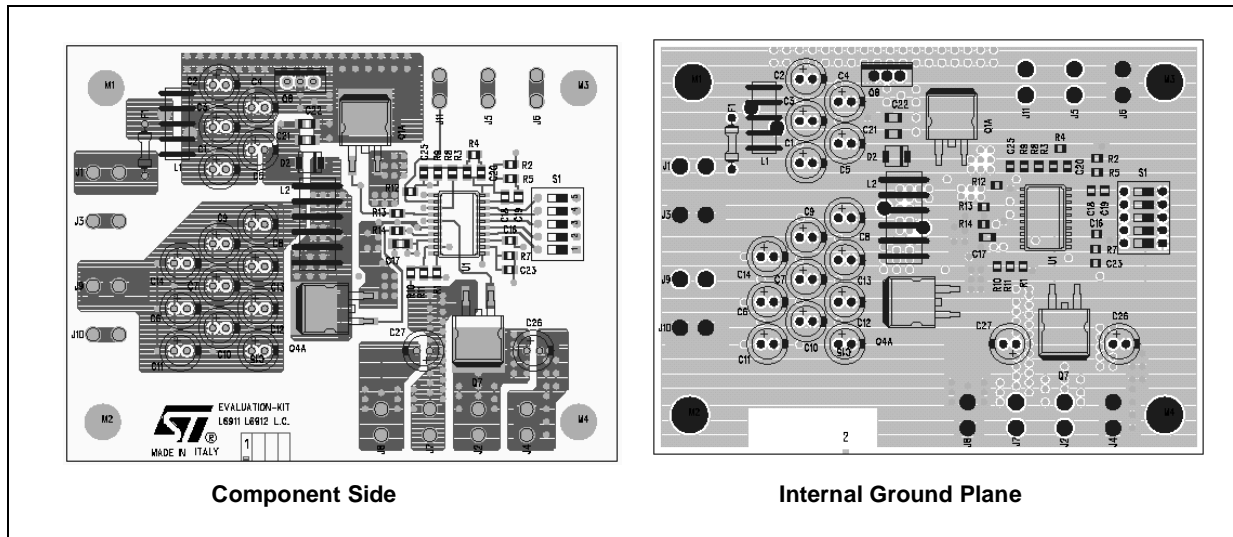
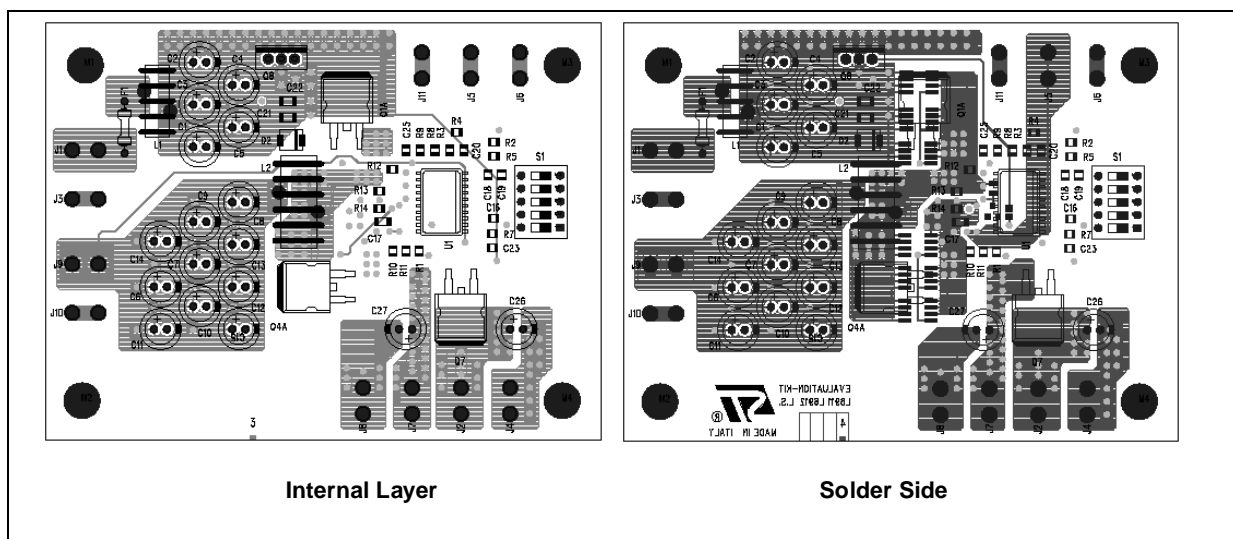

Figure 15. PCB and Components Layouts



# L6911C

## Application Circuit Examples

Figure 16 reports the schematic circuit for a motherboard chipset power supply. This application works from a single 5V power supply and is able to deliver up to 10A with a 300KHz switching frequency.

**Figure 16. Motherboard chipset power supply; 2.5Vout, 10A**

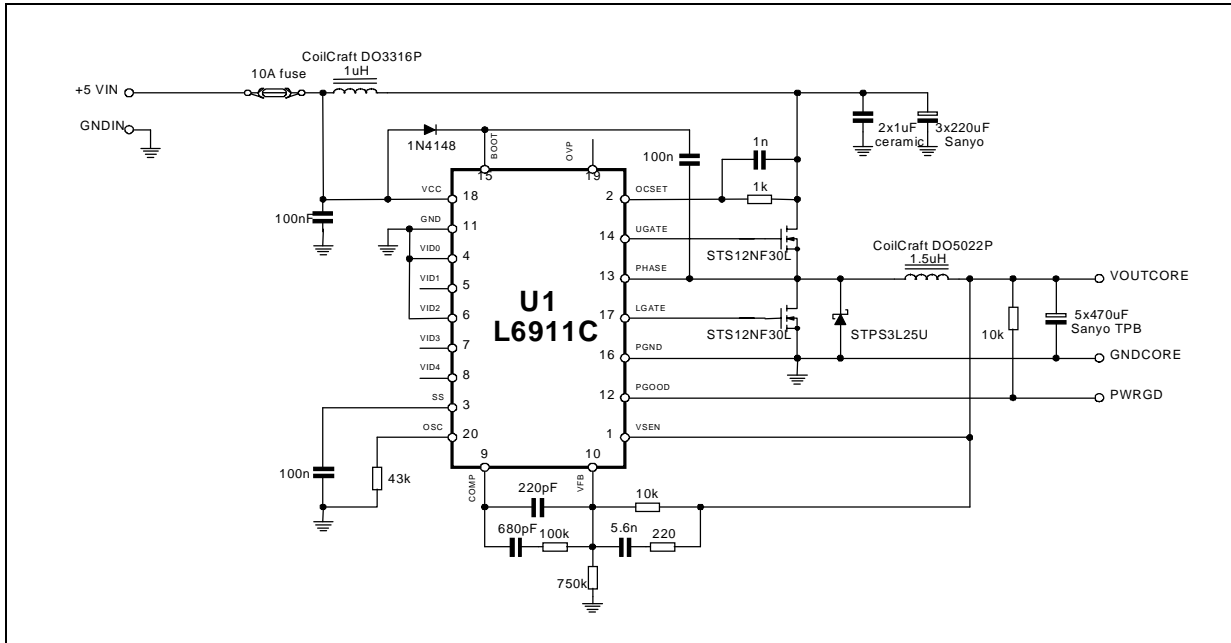

| DIM. | mm                 |      |       | inch  |       |       |
|------|--------------------|------|-------|-------|-------|-------|
|      | MIN.               | TYP. | MAX.  | MIN.  | TYP.  | MAX.  |
| A    | 2.35               |      | 2.65  | 0.093 |       | 0.104 |
| A1   | 0.1                |      | 0.3   | 0.004 |       | 0.012 |
| B    | 0.33               |      | 0.51  | 0.013 |       | 0.020 |
| C    | 0.23               |      | 0.32  | 0.009 |       | 0.013 |
| D    | 12.6               |      | 13    | 0.496 |       | 0.512 |
| E    | 7.4                |      | 7.6   | 0.291 |       | 0.299 |
| e    |                    | 1.27 |       |       | 0.050 |       |
| H    | 10                 |      | 10.65 | 0.394 |       | 0.419 |
| h    | 0.25               |      | 0.75  | 0.010 |       | 0.030 |
| L    | 0.4                |      | 1.27  | 0.016 |       | 0.050 |
| K    | 0° (min.)8° (max.) |      |       |       |       |       |

## OUTLINE AND MECHANICAL DATA

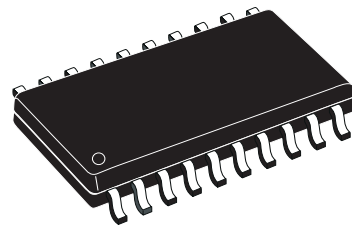

**SO20**

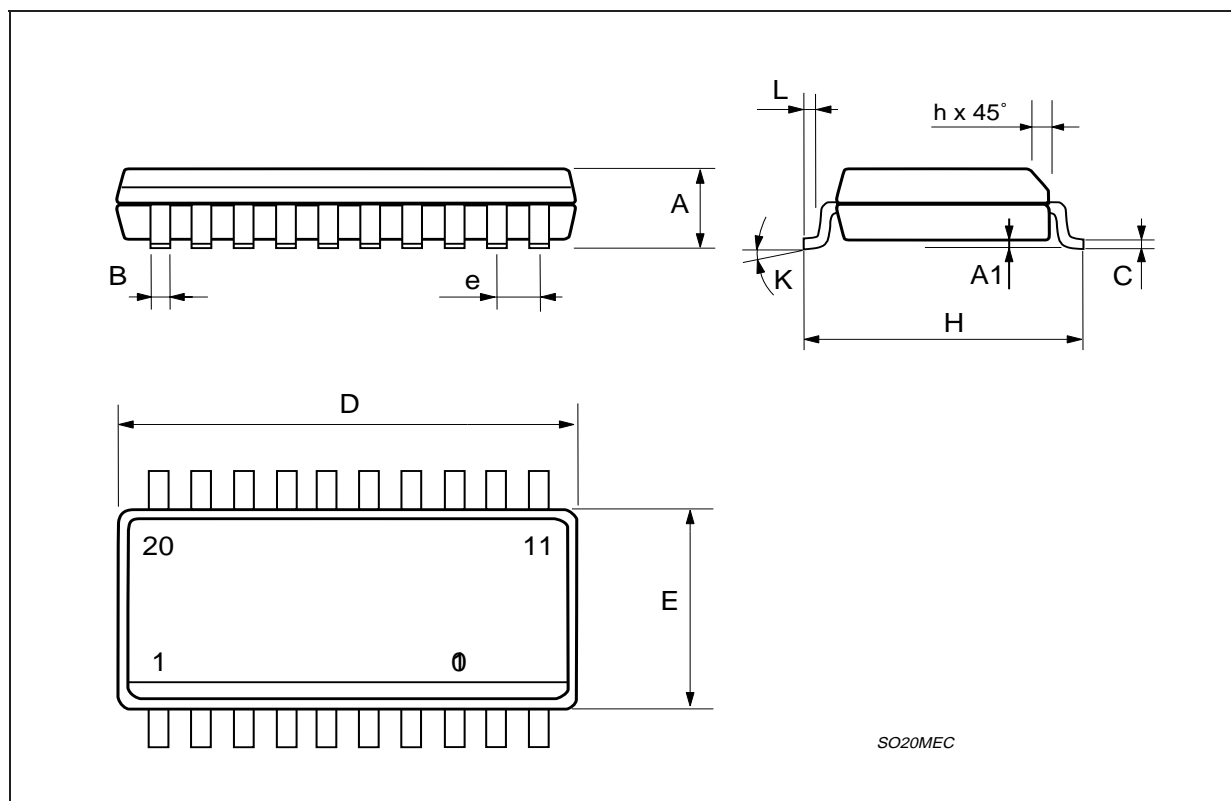

Information furnished is believed to be accurate and reliable. However, STMicroelectronics assumes no responsibility for the consequences of use of such information nor for any infringement of patents or other rights of third parties which may result from its use. No license is granted by implication or otherwise under any patent or patent rights of STMicroelectronics. Specifications mentioned in this publication are subject to change without notice. This publication supersedes and replaces all information previously supplied. STMicroelectronics products are not authorized for use as critical components in life support devices or systems without express written approval of STMicroelectronics.

The ST logo is a registered trademark of STMicroelectronics  
© 2001 STMicroelectronics - All Rights Reserved

STMicroelectronics GROUP OF COMPANIES  
Australia - Brazil - China - Finland - France - Germany - Hong Kong - India - Italy - Japan - Malaysia - Malta - Morocco - Singapore - Spain  
- Sweden - Switzerland - United Kingdom - U.S.A.  
<http://www.st.com>