



STA510

60V 5A POWER FULL BRIDGE

PRODUCT PREVIEW

- MINIMUM INPUT OUTPUT PULSE WIDTH DISTORTION
- 150mΩ R_{dsON} NDMOS OUTPUT STAGE
- CMOS COMPATIBLE LOGIC INPUTS
- THERMAL PROTECTION
- WARNING OUTPUT: THERMAL, OVERLOAD
- UNDER VOLTAGE PROTECTION ON V_{REG}
- OVERVOLTAGE PROTECTION
- TWO LEVELS CURRENT PROTECTION

MULTIPOWER BCD TECHNOLOGY

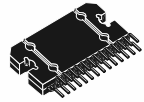

Flexiwatt27

ORDERING NUMBER: STA510

DESCRIPTION

STA510 is a monolithic full bridge stage in Multipower BCD Technology. The device is particularly designed to make the output stage of classD audio amplifier capable to deliver 100W undistorted output power on 8Ω load. The input pins have threshold proportional to V_{lbias} pin voltage. The commutation speed of the output stage is settable with an external resistor (Curref pin) to choice for each application the best compromise of THD versus EMI and current

spikes.

The overcurrent protection works in two steps, the first one, at a lower value limits the current terminating the pulse (independently to the input) when the current in the power output MOS reaches a first threshold: it is aimed to act in case of overload and its effect is to stabilize the mean current in the load to a limit value. The second step shuts down completely the device and restarts the power on sequence if the current reaches a second (higher) threshold: it is aimed to act in case of short circuit, when the first limitation can fail.

AUDIO APPLICATION CIRCUIT

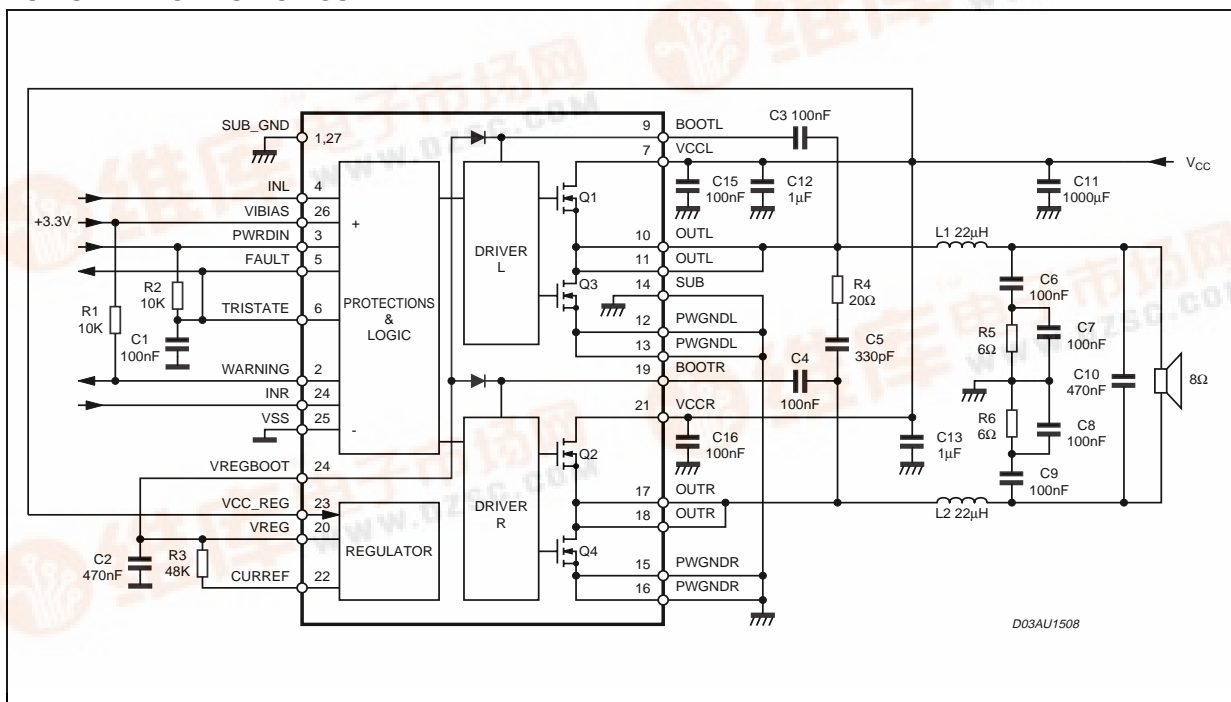

D03AU1508



STA510

PIN FUNCTION

| N° | Pin | Description |
|--------|-----------|---|
| 1, 27 | SUB_GND | Substrate (frame) and signal ground |
| 2 | WARNING | Warning advisor |
| 3 | PWRDN | St-by input pin |
| 4 | INL | Input left arm |
| 5 | FAULT | Fault adviosor |
| 6 | TRISTATE | Hi-Z input pin |
| 7 | VCCL | Positive power supply left arm |
| 8 | VREG_BOOT | VREG input for bootstrap charging |
| 9 | BOOTL | Bootstrap cap. left arm |
| 10, 11 | OUTL | Output left arm |
| 12,13 | PWRGNDL | Power GND left arm |
| 14 | SUB | Substrate (plug near powers) |
| 15, 16 | PWRGNDR | Power GND right arm |
| 17, 18 | OUTR | Output right arm |
| 19 | BOOTR | Bootstrap cap. right arm |
| 20 | VREG | Regulator output (for filtering) |
| 21 | VCCR | Positive power supply right arm |
| 22 | CURREF | Resistor for commutation speed setting |
| 23 | VCC_REG | Positive power supply for the regulator |
| 24 | INR | Input right arm |
| 25 | VSS | Input logic ground |
| 26 | VIBIAS | High logic state setting voltage |

FUNCTIONAL PIN STATUS

| PIN NAME | Logical value | IC -STATUS |
|-----------|---------------|---|
| FAULT | 0 | Fault detected (Short circuit, or Thermal ..) |
| FAULT* | 1 | Normal Operation |
| TRI-STATE | 0 | All powers in Hi-Z state |
| TRI-STATE | 1 | Normal operation |
| PWRDN | 0 | Low absorpion |
| PWRDN | 1 | Normal operation |
| WARNING | 0 | Temperature of the IC =130°C; overload |
| WARNING* | 1 | Normal operation |

* : The pin is open collector. To have the high logic value, it needs to be pulled up by a resistor.

PIN CONNECTION

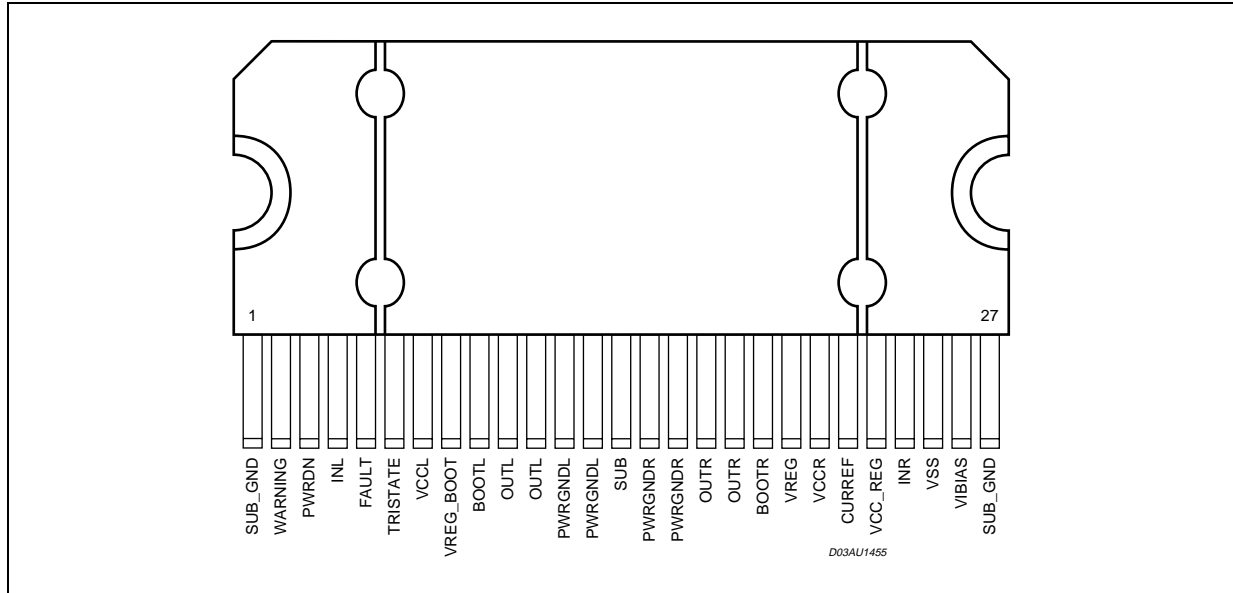

ABSOLUTE MAXIMUM RATINGS

| Symbol | Parameter | Value | Unit |
|----------------|---|------------|------|
| V_{CE} | DC Supply Voltage (VCCR, VCCL, VCC_REG) | 60 | V |
| V_{max} | Logic Voltage (INL, INR, VIBIAS, TRISTATE, PWRDN) | 5.5* | V |
| V_{REG} | Regulator Voltage (VREG, VREG_BOOT, CURREF) | 8 | V |
| V_{od} | Voltage on Open Drain Pins (WARNING, FAULT) | 60 | V |
| T_{op} | Operating Temperature Range | 0 to 70 | °C |
| T_{stg}, T_j | Storage and Junction Temperature | -40 to 150 | °C |

*: referred to V_{SS}

ELECTRICAL CHARACTERISTICS ($V_{Ibias} = 3.3V$; $V_{cc} = 45V$; $T_{amb} = 25^\circ C$ unless otherwise specified referred to "AUDIO APPLICATION CIRCUIT" pag. 1)

| Symbol | Parameter | Test conditions | Min. | Typ. | Max. | Unit |
|-------------|----------------------------------|--|------|------|------|----------|
| R_{dsON} | Power Nchannel MOSFET RdsON | $I_d=1A$; | | 0.15 | 0.20 | Ω |
| I_{dss} | Power Nchannel leakage Idss | | | TBD | | μA |
| G_{NH} | Power Nchannel RdsON Matching | $I_d = 1A$; High Right with High Left | 95 | | | % |
| G_{NL} | Power Nchannel RdsON Matching | $I_d = 1A$; Low Right with Low Left | 95 | | | % |
| D_{t-s} | Low current Dead Time (static) | see test circuit in fig. 1 | | 20 | 40 | ns |
| D_{t-d} | High current Dead Time (dinamic) | $I_d = 5A$; see fig 3 | | 40 | 80 | ns |
| $t_{d ON}$ | Turn-on delay time | Resistive load | | | 100 | ns |
| $t_{d OFF}$ | Turn-off delay time | Resistive load; | | | 100 | ns |

STA510

ELECTRICAL CHARACTERISTICS (continued)

| Symbol | Parameter | Test conditions | Min. | Typ. | Max. | Unit |
|-----------------|--|---|-----------------------|-----------------------|-----------------------|---------|
| t_r | Rise time | Resistive load; | | | 50 | ns |
| t_f | Fall time | Resistive load; | | | 50 | ns |
| V_{CC} | Supply voltage operating range | | 11 | | 55 | V |
| V_{IN-H} | High level input voltage | | | $V_{Ibias}/2 + 150mV$ | $V_{Ibias}/2 + 300mV$ | V |
| V_{IN-L} | Low level input voltage | | $V_{Ibias}/2 - 300mV$ | $V_{Ibias}/2 - 130mV$ | | V |
| I_{IN-H} | Hi level Input current | Pin voltage = V_{Ibias} | | | 1 | μA |
| I_{IN-L} | Low level input current | Pin voltage = 0.3V | | | 1 | μA |
| $I_{PWRDN-H}$ | Hi level PWRDN pin input current | $I_{bias} = 3.3V$ | | 35 | | μA |
| V_L | Low logical state voltage (pin PWRDN, TRISTATE) | $I_{bias} = 3.3V$ | 0.8 | 1 | | V |
| V_H | High logical state voltage (pin PWRDN, TRISTATE) | $I_{bias} = 3.3V$ | | 1.9 | 2.2 | V |
| $I_{VCC-PWRDN}$ | Supply current from Vcc in Power Down | PWRDN = 0; TRISTATE = 0 | | 0.25 | | mA |
| $I_{VCC-hiz}$ | Supply current from Vcc in Tri-state | PWRDN = 1; Tri-state=0; | | TBD | | mA |
| I_{VCC} | Supply current from Vcc in operation | No LOAD Input pulse width = 50% Duty; Switching Frequency = 384Khz; No LC filters; | | 100 | | mA |
| I_{lim} | Current Limit (Overload) | | 6 | 7 | 8 | A |
| I_{sc} | Short circuit current threshold | | 7 | 8 | 9 | A |
| V_{UV} | Undervoltage protection threshold on VREG | | | 7 | | V |
| V_{OV} | Overvoltage protection threshold on VCC | | 55 | 60 | | V |
| V_{DROPO} | Dropout from VCC to VREG | | | 4 | | V |

LOGIC TRUTH TABLE (see fig. 2)

| TRI-STATE | INL | INR | HSL (Q1) | HSR (Q2) | LSL (Q3) | LSR (Q4) | OUTPUT MODE |
|-----------|-----|-----|----------|----------|----------|----------|-------------|
| 0 | x | x | OFF | OFF | OFF | OFF | Hi-Z |
| 1 | 0 | 0 | OFF | OFF | ON | ON | DUMP |
| 1 | 0 | 1 | OFF | ON | ON | OFF | NEGATIVE |
| 1 | 1 | 0 | ON | OFF | OFF | ON | POSITIVE |
| 1 | 1 | 1 | ON | ON | OFF | OFF | Not used |

Figure 1. Test Circuit.

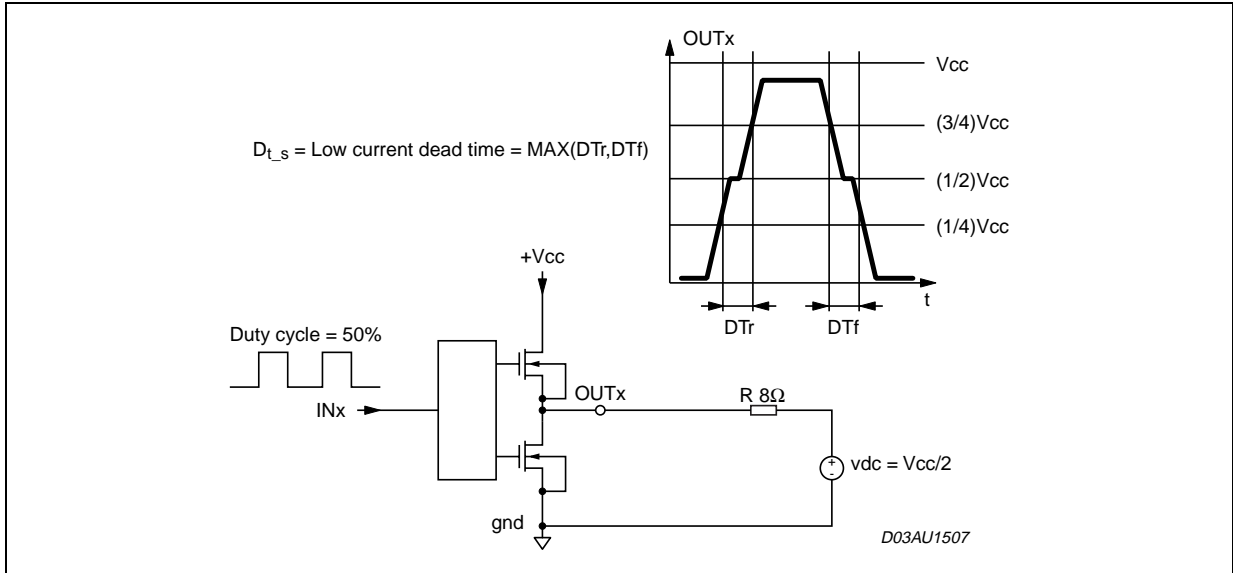

Figure 2.

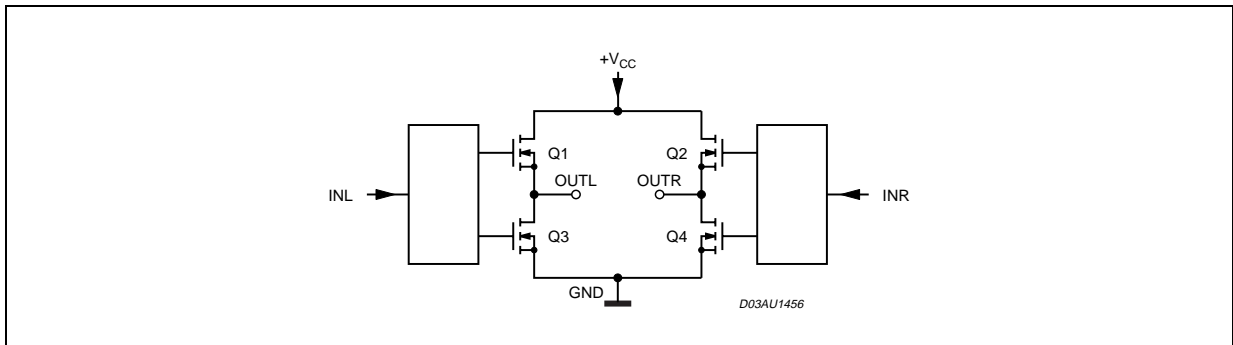
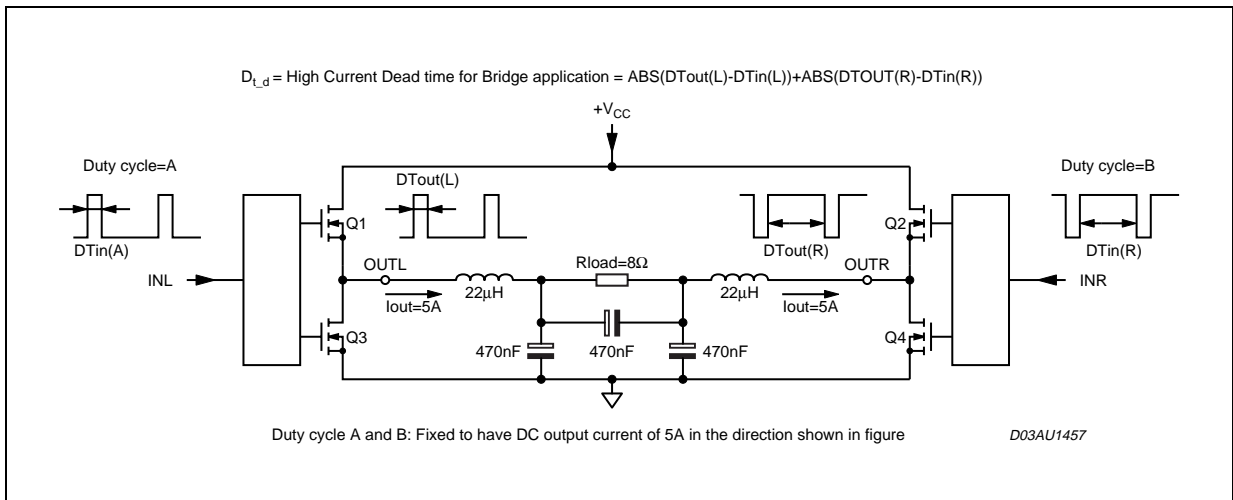

Figure 3.



STA510

| DIM. | mm | | | inch | | |
|--------|-------|-------|------------|-------|-------|-------|
| | MIN. | TYP. | MAX. | MIN. | TYP. | MAX. |
| A | 4.45 | 4.50 | 4.65 | 0.175 | 0.177 | 0.183 |
| B | 1.80 | 1.90 | 2.00 | 0.070 | 0.074 | 0.079 |
| C | | 1.40 | | | 0.055 | |
| D | 0.75 | 0.90 | 1.05 | 0.029 | 0.035 | 0.041 |
| E | 0.37 | 0.39 | 0.42 | 0.014 | 0.015 | 0.016 |
| F (1) | | | 0.57 | | | 0.022 |
| G | 0.80 | 1.00 | 1.20 | 0.031 | 0.040 | 0.047 |
| G1 | 25.75 | 26.00 | 26.25 | 1.014 | 1.023 | 1.033 |
| H (2) | 28.90 | 29.23 | 29.30 | 1.139 | 1.150 | 1.153 |
| H1 | | 17.00 | | | 0.669 | |
| H2 | | 12.80 | | | 0.503 | |
| H3 | | 0.80 | | | 0.031 | |
| L (2) | 22.07 | 22.47 | 22.87 | 0.869 | 0.884 | 0.904 |
| L1 | 18.57 | 18.97 | 19.37 | 0.731 | 0.747 | 0.762 |
| L2 (2) | 15.50 | 15.70 | 15.90 | 0.610 | 0.618 | 0.626 |
| L3 | 7.70 | 7.85 | 7.95 | 0.303 | 0.309 | 0.313 |
| L4 | | 5 | | | 0.197 | |
| L5 | | 3.5 | | | 0.138 | |
| M | 3.70 | 4.00 | 4.30 | 0.145 | 0.157 | 0.169 |
| M1 | 3.60 | 4.00 | 4.40 | 0.142 | 0.157 | 0.173 |
| N | | 2.20 | | | 0.086 | |
| O | | 2 | | | 0.079 | |
| R | | 1.70 | | | 0.067 | |
| R1 | | 0.5 | | | 0.02 | |
| R2 | | 0.3 | | | 0.12 | |
| R3 | | 1.25 | | | 0.049 | |
| R4 | | 0.50 | | | 0.019 | |
| V | | | 5° (Typ.) | | | |
| V1 | | | 3° (Typ.) | | | |
| V2 | | | 20° (Typ.) | | | |
| V3 | | | 45° (Typ.) | | | |

OUTLINE AND MECHANICAL DATA

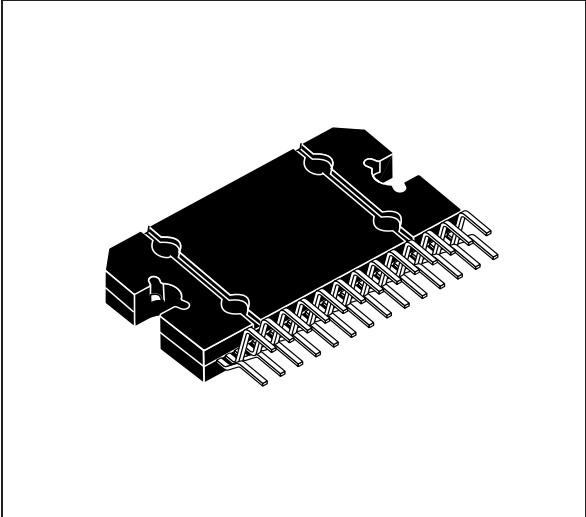

Flexiwatt27 (vertical)

(1): dam-bar protusion not included
 (2): molding protusion included

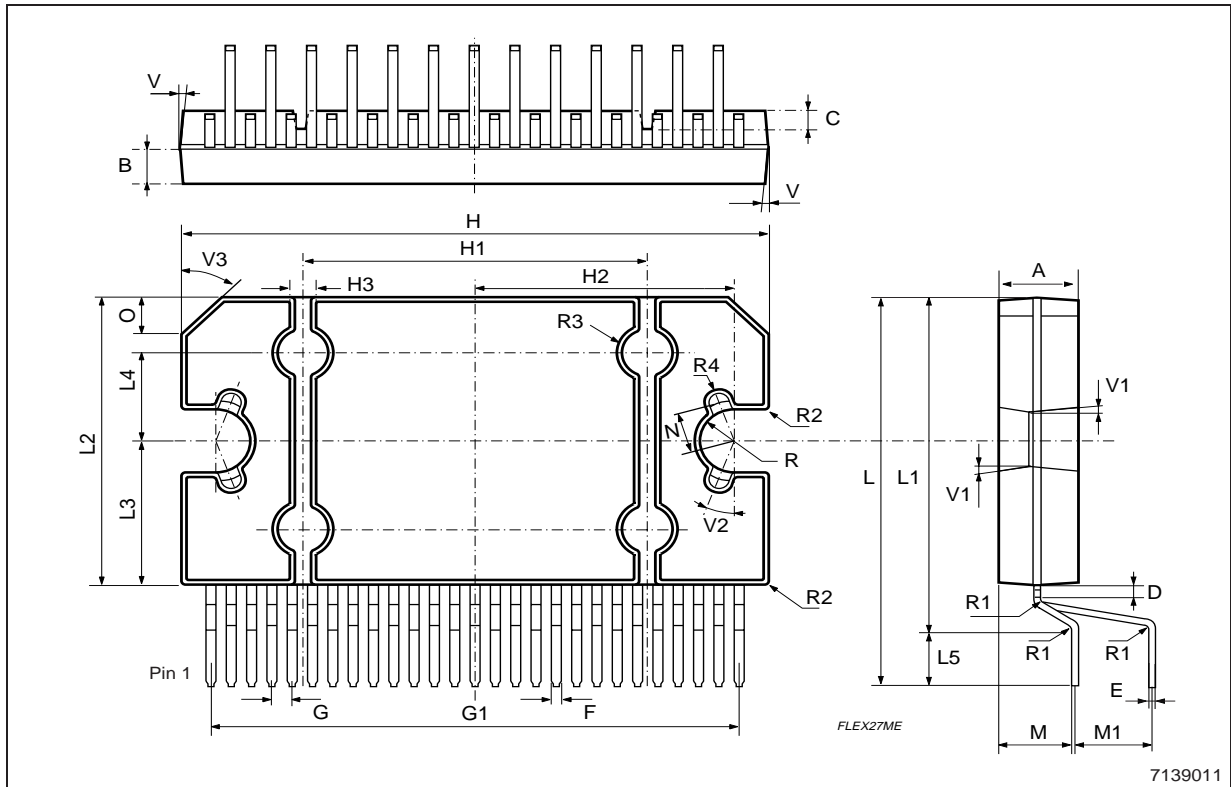

Information furnished is believed to be accurate and reliable. However, STMicroelectronics assumes no responsibility for the consequences of use of such information nor for any infringement of patents or other rights of third parties which may result from its use. No license is granted by implication or otherwise under any patent or patent rights of STMicroelectronics. Specifications mentioned in this publication are subject to change without notice. This publication supersedes and replaces all information previously supplied. STMicroelectronics products are not authorized for use as critical components in life support devices or systems without express written approval of STMicroelectronics.

The ST logo is a registered trademark of STMicroelectronics
© 2003 STMicroelectronics - All Rights Reserved

DDX is a trademark of Apogee technology inc.

STMicroelectronics GROUP OF COMPANIES
Australia - Brazil - Canada - China - Finland - France - Germany - Hong Kong - India - Israel - Italy - Japan -Malaysia - Malta - Morocco -
Singapore - Spain - Sweden - Switzerland - United Kingdom - United States.
<http://www.st.com>