

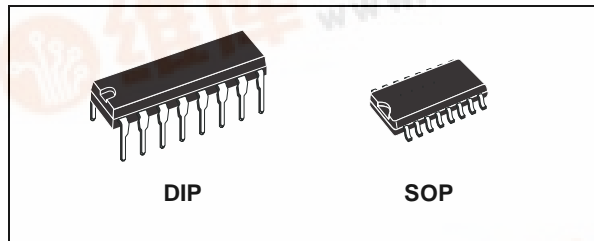

# HCF4050B

## HEX BUFFER/CONVERTER (NON INVERTING)

- PROPAGATION DELAY TIME :  
 $t_{PD} = 40\text{ns}$  (TYP.) at  $V_{DD} = 10\text{V}$   $C_L = 50\text{pF}$
- HIGH TO LOW LEVEL LOGIC CONVERSION
- HIGH "SINK" AND "SOURCE" CURRENT CAPABILITY
- QUIESCENT CURRENT SPECIFIED UP TO 20V
- 5V, 10V AND 15V PARAMETRIC RATINGS
- INPUT LEAKAGE CURRENT  
 $I_l = 100\text{nA}$  (MAX) AT  $V_{DD} = 18\text{V}$   $T_A = 25^\circ\text{C}$
- 100% TESTED FOR QUIESCENT CURRENT
- MEETS ALL REQUIREMENTS OF JEDEC JESD13B " STANDARD SPECIFICATIONS FOR DESCRIPTION OF B SERIES CMOS DEVICES"



### ORDER CODES

PACKAGE	TUBE	T & R
DIP	HCF4050BEY	
SOP	HCF4050BM1	HCF4050M013TR

### DESCRIPTION

The HCF4050B is a monolithic integrated circuit fabricated in Metal Oxide Semiconductor technology available in DIP and SOP packages. It is an non inverting Hex Buffer/Converter and feature logic level conversions using only one supply voltage ( $V_{DD}$ ).

The input high level signal ( $V_{IH}$ ) can exceed the  $V_{DD}$  supply voltage when these devices are used for logic level conversions. This device is intended for use as CMOS to DTL/TTL converters and can drive directly two DTL/TTL loads ( $V_{DD}=5\text{V}$ ,  $V_{OL}\leq 0.4\text{V}$  and  $I_{OL}\leq 3.2\text{mA}$ ).

### PIN CONNECTION

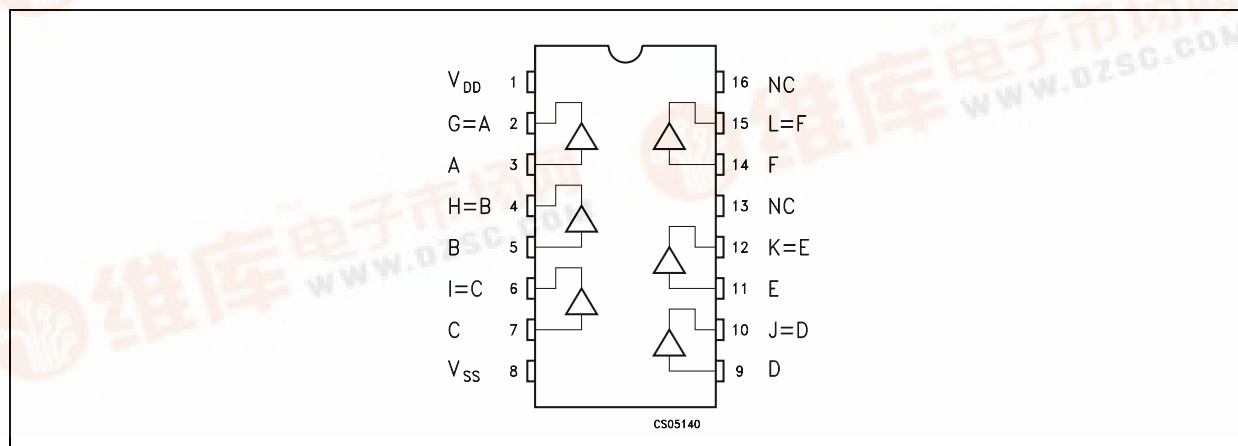

## HCF4050B

### INPUT EQUIVALENT CIRCUIT

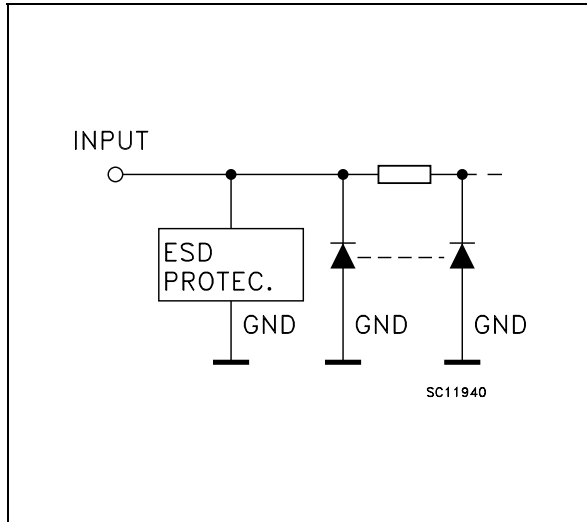

### PIN DESCRIPTION

PIN No	SYMBOL	NAME AND FUNCTION
3, 5, 7, 9, 11, 14	A, B, C, D, E, F	Data Inputs
2, 4, 6, 10, 12, 15	G, H, I, J, K, L	Data Outputs
13, 16	NC	Not Connected
8	$V_{SS}$	Negative Supply Voltage
1	$V_{DD}$	Positive Supply Voltage

### TRUTH TABLE

INPUTS	OUTPUTS
A, B, C, D, E, F	G, H, I, J, K, L
L	L
H	H

### ABSOLUTE MAXIMUM RATINGS

Symbol	Parameter	Value	Unit
$V_{DD}$	Supply Voltage	-0.5 to +22	V
$V_I$	DC Input Voltage	-0.5 to +18	V
$I_I$	DC Input Current	$\pm 10$	mA
$P_D$	Power Dissipation per Package	200	mW
	Power Dissipation per Output Transistor	100	mW
$T_{op}$	Operating Temperature	-55 to +125	$^{\circ}\text{C}$
$T_{stg}$	Storage Temperature	-65 to +150	$^{\circ}\text{C}$

Absolute Maximum Ratings are those values beyond which damage to the device may occur. Functional operation under these conditions is not implied.

All voltage values are referred to  $V_{SS}$  pin voltage.

### RECOMMENDED OPERATING CONDITIONS

Symbol	Parameter	Value	Unit
$V_{DD}$	Supply Voltage	3 to 20	V
$V_I$	Input Voltage	-0.5 to 15V	V
$T_{op}$	Operating Temperature	-55 to 125	$^{\circ}\text{C}$

## DC SPECIFICATIONS

Symbol	Parameter	Test Condition				Value						Unit	
		V <sub>I</sub> (V)	V <sub>O</sub> (V)	I <sub>ol</sub>   ( $\mu$ A)	V <sub>DD</sub> (V)	T <sub>A</sub> = 25°C			-40 to 85°C		-55 to 125°C		
						Min.	Typ.	Max.	Min.	Max.	Min.		Max.
I <sub>L</sub>	Quiescent Current	0/5			5		0.02	1		30		30	$\mu$ A
		0/10			10		0.02	2		60		60	
		0/15			15		0.02	4		120		120	
		0/20			20		0.04	20		600		600	
V <sub>OH</sub>	High Level Output Voltage	0/5		<1	5	4.95			4.95		4.95		V
		0/10		<1	10	9.95			9.95		9.95		
		0/15		<1	15	14.95			14.95		14.95		
V <sub>OL</sub>	Low Level Output Voltage	5/0		<1	5		0.05			0.05		0.05	V
		10/0		<1	10		0.05			0.05		0.05	
		15/0		<1	15		0.05			0.05		0.05	
V <sub>IH</sub>	High Level Input Voltage		0.5/4.5	<1	5	3.5			3.5		3.5		V
			1/9	<1	10	7			7		7		
			1.5/13.5	<1	15	11			11		11		
V <sub>IL</sub>	Low Level Input Voltage		4.5/0.5	<1	5			1.5		1.5		1.5	V
			9/1	<1	10			3		3		3	
			13.5/1.5	<1	15			4		4		4	
I <sub>OH</sub>	Output Drive Current	0/5	2.5	<1	5	-1.25	-6.4		-0.42		-0.42		mA
		0/5	4.6	<1	5	-0.51	-1.6		-0.38		-0.38		
		0/10	9.5	<1	10	-1.25	-3.6		-1		-1		
		0/15	13.5	<1	15	-3.75	-12		-3		-3		
I <sub>OL</sub>	Output Sink Current	0/5	0.4	<1	5	3.2	6.4		2.6		2.6		mA
		0/10	0.5	<1	10	8	16		6.6		6.6		
		0/15	1.5	<1	15	24	48		19		19		
I <sub>I</sub>	Input Leakage Current	0/18	Any Input		18		$\pm 10^{-5}$	$\pm 0.1$		$\pm 1$		$\pm 1$	$\mu$ A
C <sub>I</sub>	Input Capacitance		Any Input				5	7.5					pF

The Noise Margin for both "1" and "0" level is: 1V min. with V<sub>DD</sub>=5V, 2V min. with V<sub>DD</sub>=10V, 2.5V min. with V<sub>DD</sub>=15V

## HCF4050B

### DYNAMIC ELECTRICAL CHARACTERISTICS ( $T_{amb} = 25^{\circ}\text{C}$ , $C_L = 50\text{pF}$ , $R_L = 200\text{K}\Omega$ , $t_r = t_f = 20\text{ ns}$ )

Symbol	Parameter	Test Condition		Value (*)			Unit
		$V_{DD}$ (V)	$V_I$ (V)	Min.	Typ.	Max.	
$t_{TLH}$	Output Transition Time	5	5		80	160	ns
		10	10		40	80	
		15	15		30	60	
$t_{THL}$	Output Transition Time	5	5		30	60	ns
		10	10		20	40	
		15	15		15	30	
$t_{PLH}$	Propagation Delay Time	5	5		70	140	ns
		10	10		40	80	
		5	10		45	90	
		15	15		30	60	
		5	15		40	80	
$t_{PHL}$	Propagation Delay Time	5	5		55	110	ns
		10	10		22	55	
		5	10		50	100	
		15	15		15	30	
		5	15		50	100	

(\*) Typical temperature coefficient for all  $V_{DD}$  value is 0.3 %/°C.

### TEST CIRCUIT

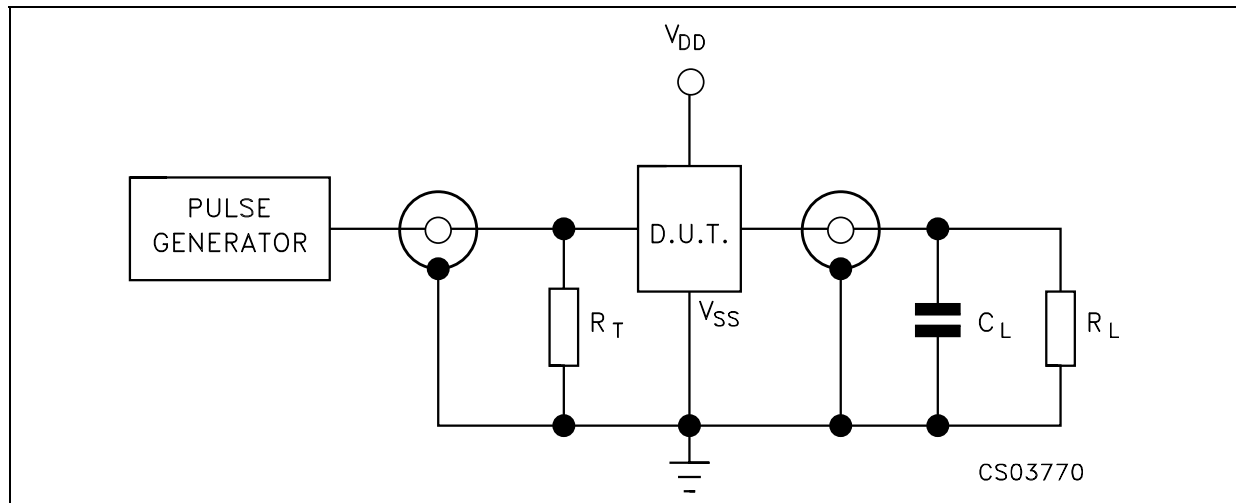

$C_L = 50\text{pF}$  or equivalent (includes jig and probe capacitance)

$R_L = 200\text{K}\Omega$

$R_T = Z_{OUT}$  of pulse generator (typically  $50\Omega$ )

WAVEFORM : PROPAGATION DELAY TIMES (f=1MHz; 50% duty cycle)

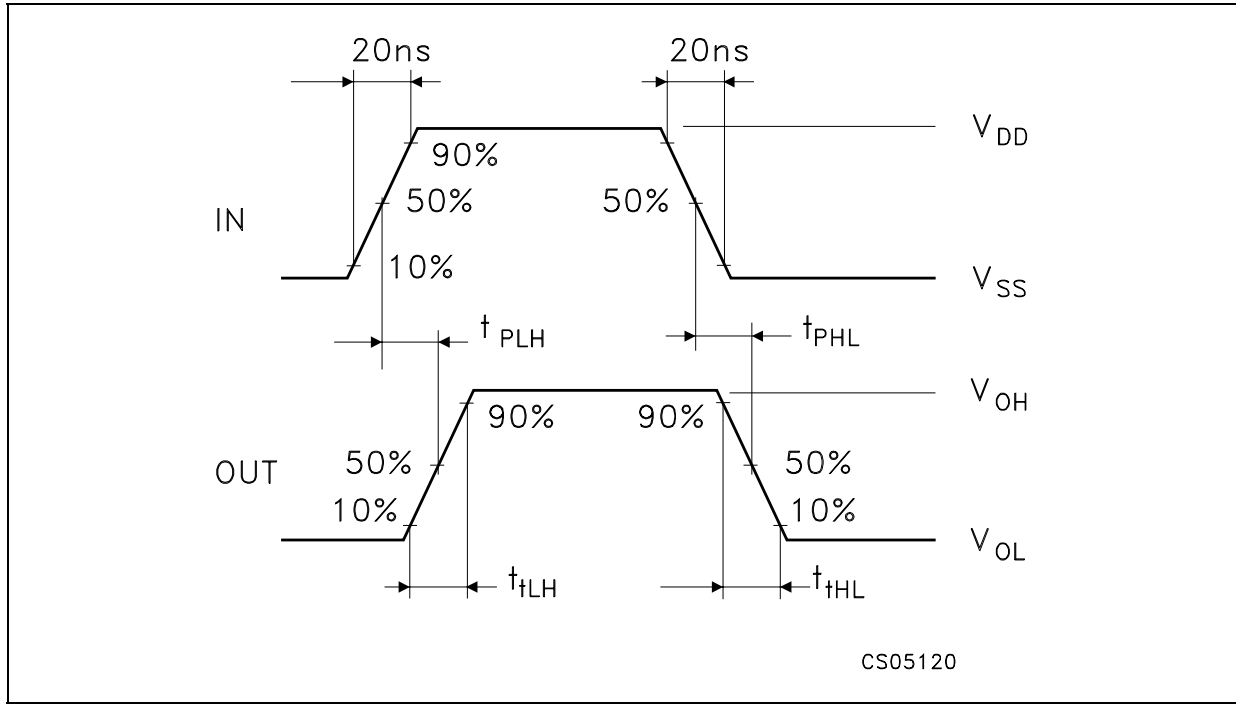

**Plastic DIP-16 (0.25) MECHANICAL DATA**

DIM.	mm.			inch		
	MIN.	TYP.	MAX.	MIN.	TYP.	MAX.
a1	0.51			0.020		
B	0.77		1.65	0.030		0.065
b		0.5			0.020	
b1		0.25			0.010	
D			20			0.787
E		8.5			0.335	
e		2.54			0.100	
e3		17.78			0.700	
F			7.1			0.280
l			5.1			0.201
L		3.3			0.130	
Z			1.27			0.050

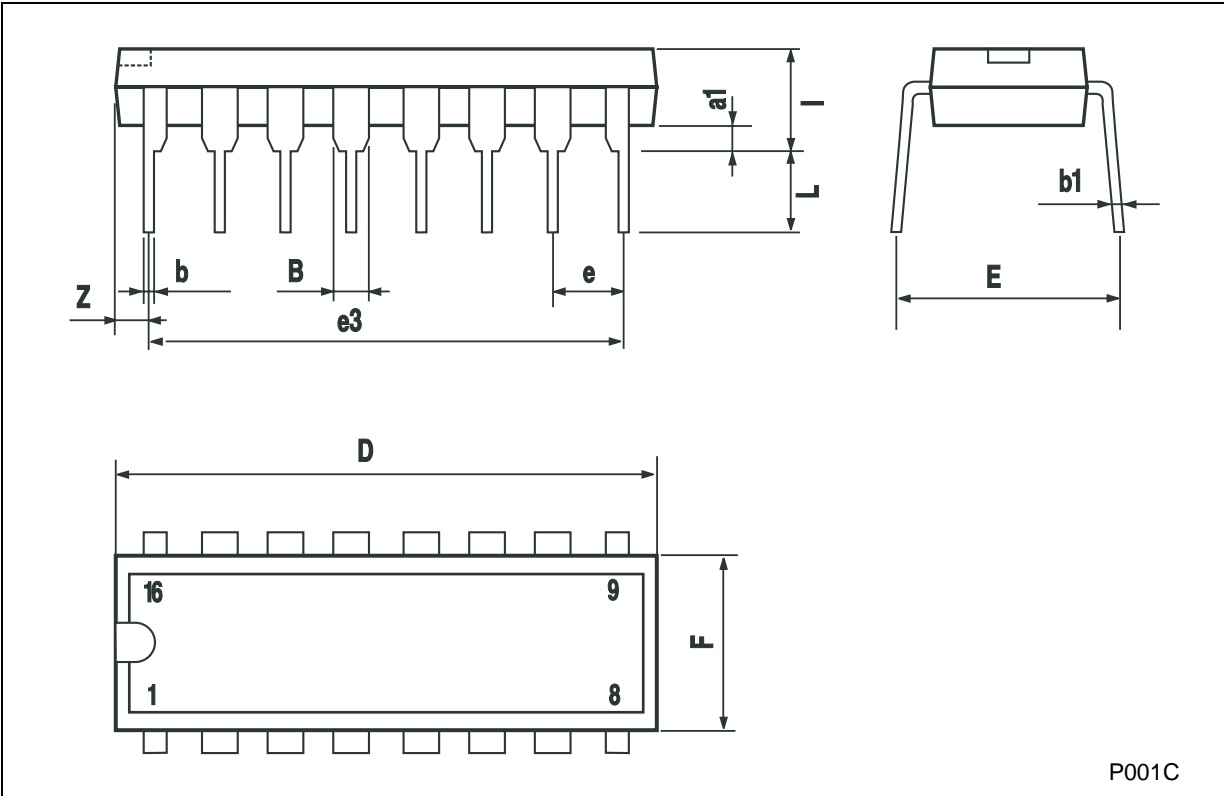

P001C

**SO-16 MECHANICAL DATA**

DIM.	mm.			inch		
	MIN.	TYP	MAX.	MIN.	TYP.	MAX.
A			1.75			0.068
a1	0.1		0.2	0.004		0.008
a2			1.65			0.064
b	0.35		0.46	0.013		0.018
b1	0.19		0.25	0.007		0.010
C		0.5			0.019	
c1	45° (typ.)					
D	9.8		10	0.385		0.393
E	5.8		6.2	0.228		0.244
e		1.27			0.050	
e3		8.89			0.350	
F	3.8		4.0	0.149		0.157
G	4.6		5.3	0.181		0.208
L	0.5		1.27	0.019		0.050
M			0.62			0.024
S	8			° (max.)		

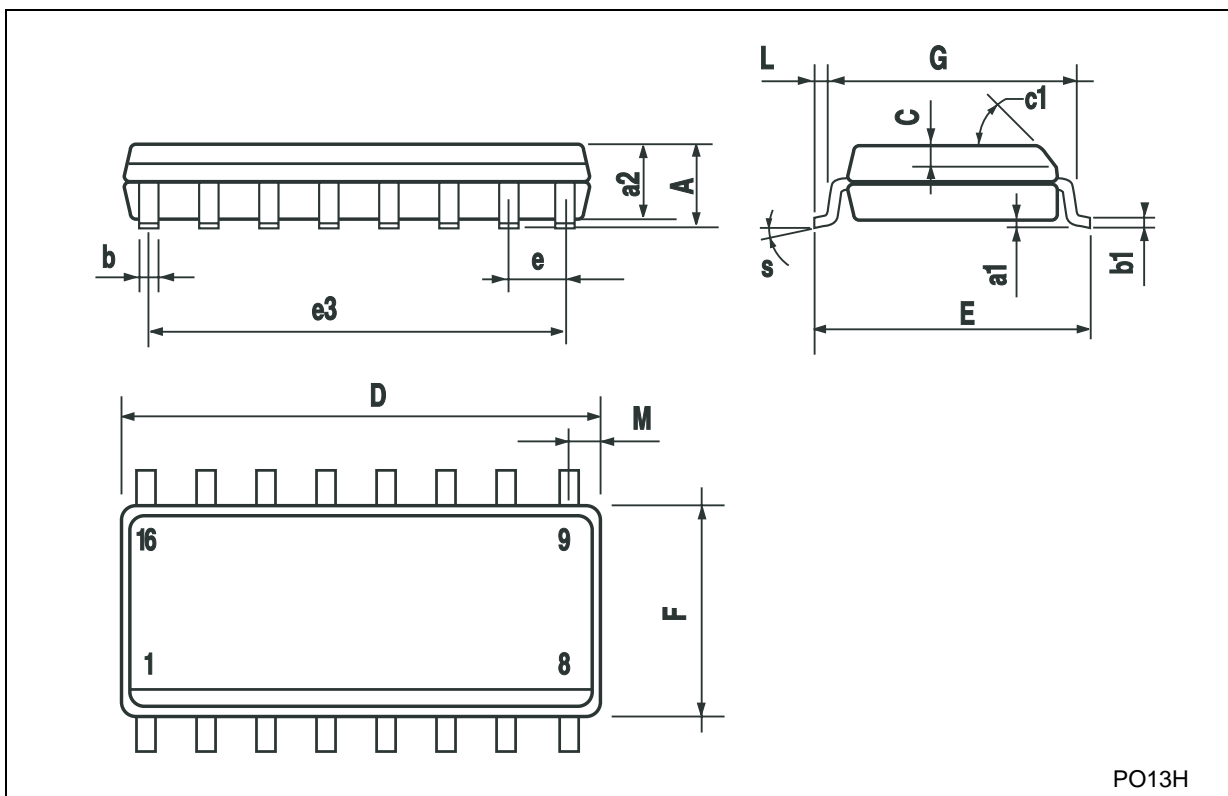

PO13H

**Tape & Reel SO-16 MECHANICAL DATA**

DIM.	mm.			inch		
	MIN.	TYP	MAX.	MIN.	TYP.	MAX.
A			330			12.992
C	12.8		13.2	0.504		0.519
D	20.2			0.795		
N	60			2.362		
T			22.4			0.882
Ao	6.45		6.65	0.254		0.262
Bo	10.3		10.5	0.406		0.414
Ko	2.1		2.3	0.082		0.090
Po	3.9		4.1	0.153		0.161
P	7.9		8.1	0.311		0.319

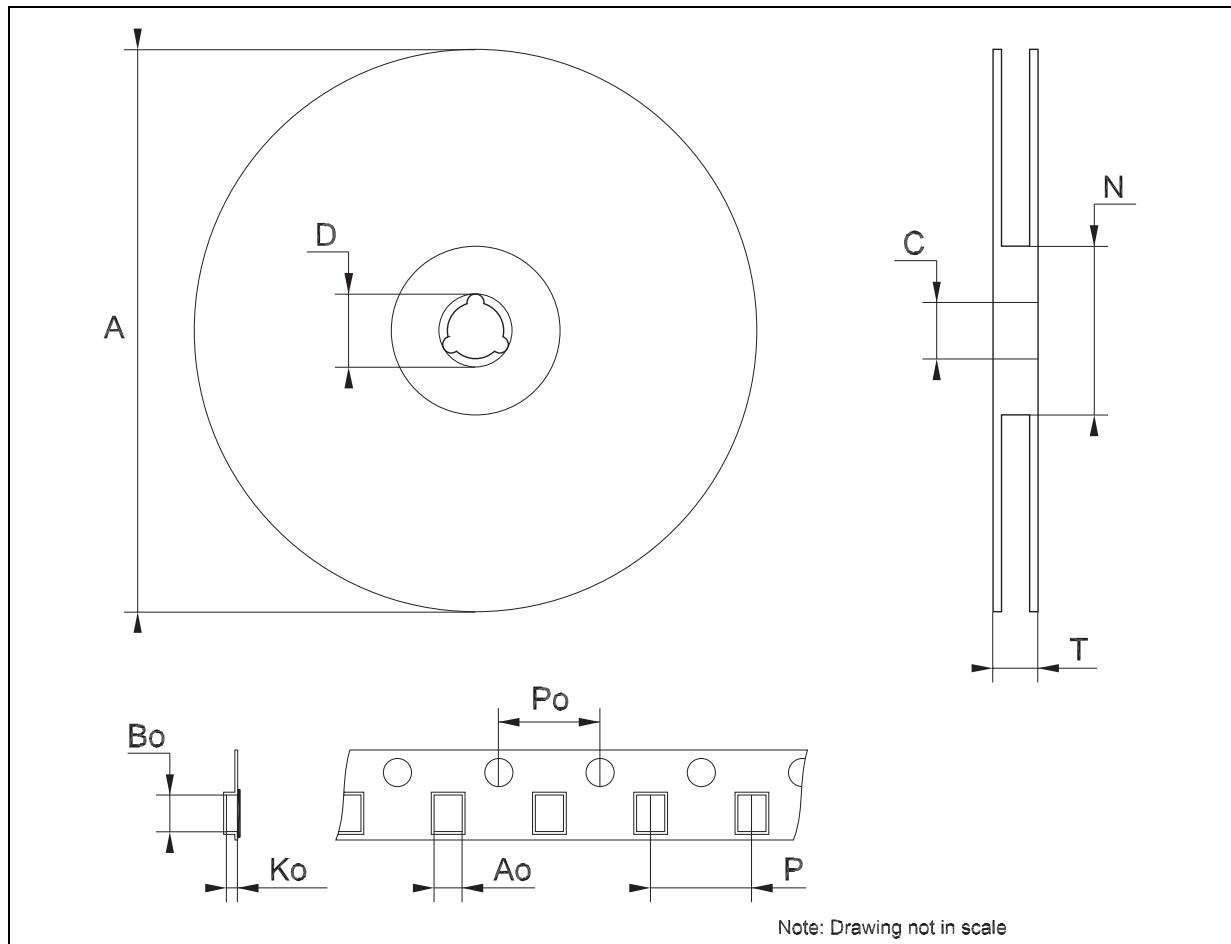



Information furnished is believed to be accurate and reliable. However, STMicroelectronics assumes no responsibility for the consequences of use of such information nor for any infringement of patents or other rights of third parties which may result from its use. No license is granted by implication or otherwise under any patent or patent rights of STMicroelectronics. Specifications mentioned in this publication are subject to change without notice. This publication supersedes and replaces all information previously supplied. STMicroelectronics products are not authorized for use as critical components in life support devices or systems without express written approval of STMicroelectronics.

© The ST logo is a registered trademark of STMicroelectronics

© 2003 STMicroelectronics - Printed in Italy - All Rights Reserved  
STMicroelectronics GROUP OF COMPANIES

Australia - Brazil - Canada - China - Finland - France - Germany - Hong Kong - India - Israel - Italy - Japan - Malaysia - Malta - Morocco  
Singapore - Spain - Sweden - Switzerland - United Kingdom - United States.

© <http://www.st.com>