

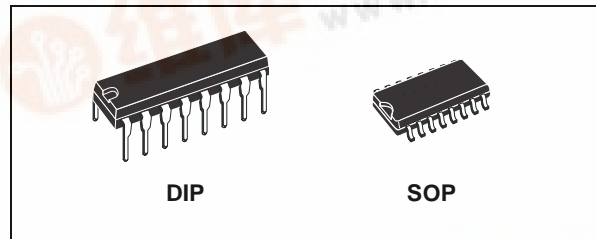

# HCF4056B

## BCD TO 7 SEGMENT DECODER /DRIVER WITH STROBED LATCH FUNCTION

- QUIESCENT CURRENT SPECIF. UP TO 20V
- OPERATION OF LIQUID CRYSTALS WITH CMOS CIRCUITS PROVIDES ULTRA LOW POWER DISPLAY.
- EQUIVALENT AC OUTPUT DRIVE FOR LIQUID CRYSTAL DISPLAYS - NO EXTERNAL CAPACITOR REQUIRED
- VOLTAGE DOUBLING ACROSS DISPLAY [( $V_{DD} - V_{EE}$ ) = 18V] RESULTS IN EFFECTIVE 36V (p-p) DRIVE ACROSS SELECTED DISPLAY SEGMENTS
- LOW OR HIGH OUTPUT LEVEL DC DRIVE FOR OTHER TYPES OF DISPLAYS
- ONE CHIP LOGIC LEVEL CONVERSION FOR DIFFERENT INPUT AND OUTPUT LEVEL SWINGS
- FULL DECODING OF ALL INPUT COMBINATIONS : "0 - 9, L, H, P, A" AND BLANK POSITIONS
- INPUT LEAKAGE CURRENT  
 $I_l = 100nA$  (MAX) AT  $V_{DD} = 18V$   $T_A = 25^\circ C$
- 100% TESTED FOR QUIESCENT CURRENT
- MEETS ALL REQUIREMENTS OF JEDEC JESD13B "STANDARD SPECIFICATIONS FOR DESCRIPTION OF B SERIES CMOS DEVICES"



### ORDER CODES

PACKAGE	TUBE	T & R
DIP	HCF4056BEY	
SOP	HCF4056BM1	HCF4056M013TR

HCF4056B is a single digit BCD to 7 segment decoder driver circuit that provides a level shifting function on the chip. This feature permits the BCD input-signal swings ( $V_{DD}$  to  $V_{SS}$ ) to be the same as or different from the 7-segment output signal swings ( $V_{DD}$  to  $V_{EE}$ ). For example, the BCD input-signal swings ( $V_{DD}$  to  $V_{SS}$ ) may be as low as 0 to -3V, whereas the output-display drive signal swing ( $V_{DD}$  to  $V_{EE}$ ) may be from 0 to -5V. If  $V_{DD}$  to  $V_{EE}$  exceeds 15V,  $V_{DD}$  to  $V_{SS}$  should be at least 4V. The 7-segment outputs are controlled by the DISPLAY-FREQUENCY (DF) input, which causes the selected segment outputs to be low, high, or a square wave output (for liquid crystal displays).

### DESCRIPTION

HCF4056B is a monolithic integrated circuit fabricated in Metal Oxide Semiconductor technology available in DIP and SOP packages.

### PIN CONNECTION

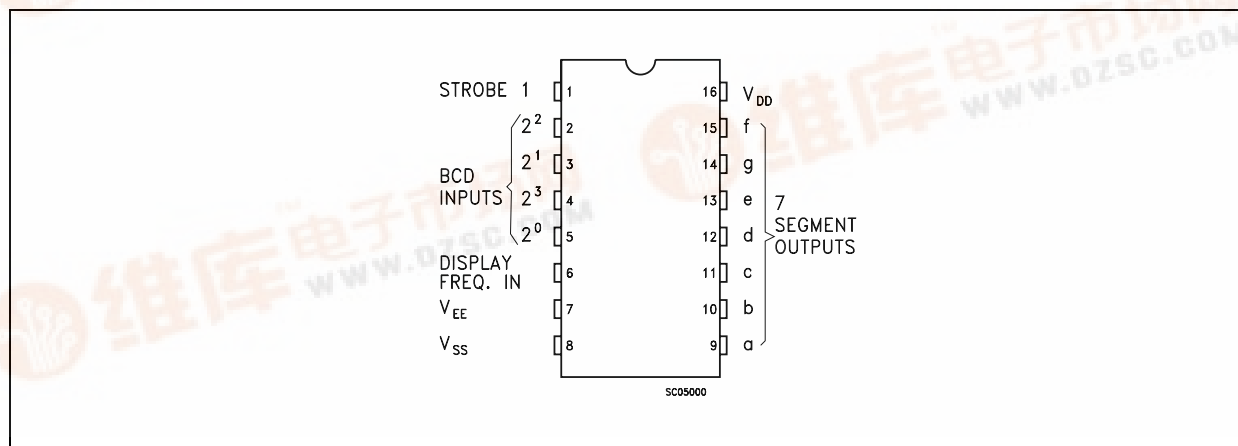

## HCF4056B

When the DF input is low, the output segments will be high when selected by the BCD inputs. When the DF input is high, the output segments will be low when selected by the BCD inputs. When a square wave is present at the DF input, the selected segments will have a square wave output that is 180° out of phase with the DF input. Those segments which are not selected will have a square wave output that is in phase with the input. DF square wave repetition rates for liquid crystal displays usually range from 30Hz (well above flicker rate) to 200Hz (well below the upper limit of the liquid crystal frequency response). HCF4056B provides a strobed-latch function at the BCD inputs. The decoding of all input combinations in

this device provides displays of 0 to 9 as well as L, P, H, A, -, and a blank position. The level shifted function permits the use of different input and output signal swings. The input swings from a low level of  $V_{SS}$  to a high level of  $V_{DD}$ , while the outputs swing from a low level of  $V_{EE}$  to the same high level of  $V_{DD}$ . Thus, the input and output swings can be selected independently of each other over a 3 to 18V range.  $V_{SS}$  may be connected to  $V_{EE}$  when no level-shift function is required. The HCF4056B, however must be used together with HCF4054B to provide the common DF output.

### INPUT EQUIVALENT CIRCUIT

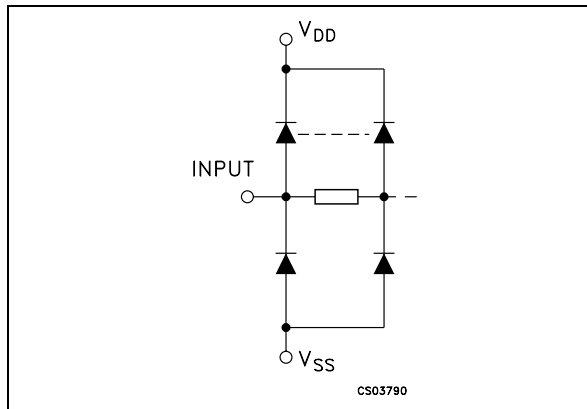

### PIN DESCRIPTION

PIN No	SYMBOL	NAME AND FUNCTION
5, 3, 2, 4	$2^0, 2^1, 2^2, 2^3$	BCD Inputs
9, 10, 11, 12, 13, 15, 14	a to g	7 - Segments Outputs
6	DISPLAY FREQ. IN	Display Frequency Input
1	STROBE	Strobe Input
7	$V_{EE}$	Negative Supply Voltage
8	$V_{SS}$	Negative Supply Voltage
16	$V_{DD}$	Positive Supply Voltage

### FUNCTIONAL DIAGRAM

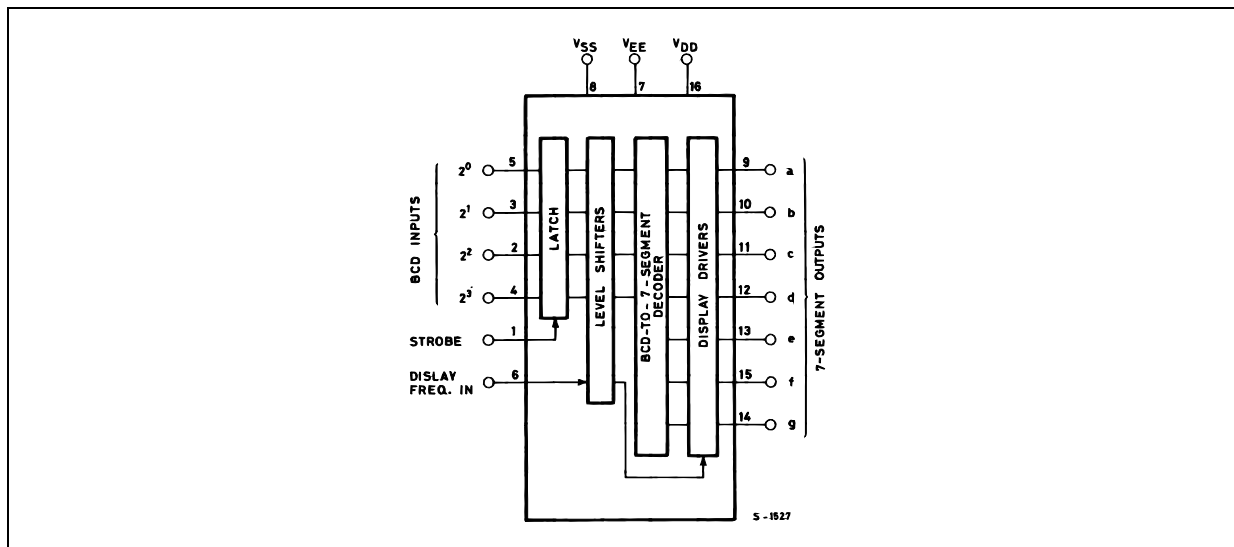

## TRUTH TABLE

INPUT CODE				OUTPUT STATE							DISPLAY CHARACTER
2 <sup>3</sup>	2 <sup>2</sup>	2 <sup>1</sup>	2 <sup>0</sup>	a	b	c	d	e	f	g	
L	L	L	L	H	H	H	H	H	H	L	0
L	L	L	H	L	H	H	L	L	L	L	1
L	L	H	L	H	H	L	H	H	L	H	2
L	L	H	H	H	H	H	H	L	L	H	3
L	H	L	L	L	H	H	L	L	H	H	4
L	H	L	H	H	L	H	H	L	H	H	5
L	H	H	L	H	L	H	H	H	H	H	6
L	H	H	H	H	H	H	L	L	L	L	7
H	L	L	L	H	H	H	H	H	H	H	8
H	L	L	H	H	H	H	H	L	H	H	9
H	L	H	L	L	L	L	H	H	H	L	L
H	L	H	H	L	H	H	L	H	H	H	H
H	H	L	L	H	H	L	L	H	H	H	P
H	H	L	H	H	H	H	L	H	H	H	A
H	H	H	L	L	L	L	L	L	L	H	-
H	H	H	H	L	L	L	L	L	L	L	BLANK

## ABSOLUTE MAXIMUM RATINGS

Symbol	Parameter	Value	Unit
V <sub>DD</sub>	Supply Voltage	-0.5 to +22	V
V <sub>I</sub>	DC Input Voltage	-0.5 to V <sub>DD</sub> + 0.5	V
I <sub>I</sub>	DC Input Current	± 10	mA
P <sub>D</sub>	Power Dissipation per Package	200	mW
	Power Dissipation per Output Transistor	100	mW
T <sub>op</sub>	Operating Temperature	-55 to +125	°C
T <sub>stg</sub>	Storage Temperature	-65 to +150	°C

Absolute Maximum Ratings are those values beyond which damage to the device may occur. Functional operation under these conditions is not implied.

All voltage values are referred to V<sub>SS</sub> pin voltage.

## RECOMMENDED OPERATING CONDITIONS

Symbol	Parameter	Value	Unit
V <sub>DD</sub>	Supply Voltage	3 to 20	V
V <sub>I</sub>	Input Voltage	0 to V <sub>DD</sub>	V
T <sub>op</sub>	Operating Temperature	-55 to 125	°C

# HCF4056B

## DC SPECIFICATIONS

Symbol	Parameter	Test Condition					Value						Unit		
		V <sub>EE</sub> (V)	V <sub>I</sub> (V)	V <sub>O</sub> (V)	V <sub>SS</sub> (V)	V <sub>DD</sub> (V)	T <sub>A</sub> = 25°C			-40 to 85°C		-55 to 125°C			
							Min.	Typ.	Max.	Min.	Max.	Min.		Max.	
I <sub>L</sub>	Quiescent Current	-5	0/5		0	5			0.04	5		150		150	μA
		0	0/10		0	10			0.04	10		300		300	
		0	0/15		0	15			0.04	20		600		600	
		0	0/20		0	20			0.08	100		3000		3000	
V <sub>OH</sub>	High Level Output Voltage	0	0/5		0	5	4.95			4.95		4.95			V
		0	0/10		0	10	9.95			9.95		9.95			
		0	0/15		0	15	14.95			14.95		14.95			
V <sub>OL</sub>	Low Level Output Voltage	0	5/0		0	5		0.05			0.05		0.05	V	
		0	10/0		0	10		0.05			0.05		0.05		
		0	15/0		0	15		0.05			0.05		0.05		
V <sub>IH</sub>	High Level Input Voltage	-5		0.5/4.5	0	5	3.5			3.5		3.5		V	
		0		1/9	0	10	7			7		7			
		0		1.5/18.5	0	15	11			11		11			
V <sub>IL</sub>	Low Level Input Voltage	5		0.5/4.5	0	5			1.5		1.5		1.5	V	
		0		9/1	0	10			3		3		3		
		0		1.5/18.5	0	15			4		4		4		
I <sub>OH</sub>	Output Drive Current	-5	0/5	4.5	0	5	-0.38	-0.9		-0.28		-0.28		mA	
		0	0/10	9.5	0	10	-0.38	-0.9		-0.28		-0.28			
		0	0/15	13.5	0	15	-1.27	-3		-0.95		-0.95			
I <sub>OL</sub>	Output Sink Current	-5	0/5	0.4	0	5	1.1	2.6		0.82		0.82		mA	
		0	0/10	0.5	0	10	1.1	2.6		0.82		0.82			
		0	0/15	1.5	0	15	2.9	6.8		2.17		2.17			
I <sub>I</sub>	Input Leakage Current (any input)	0	0/18		0	18		±10 <sup>-5</sup>	±0.1		±1		±1	μA	
C <sub>I</sub>	Input Capacitance (any input)							5	7.5					pF	

The Noise Margin for both "1" and "0" level is: 1V min. with V<sub>DD</sub>=5V, 2V min. with V<sub>DD</sub>=10V, 2.5V min. with V<sub>DD</sub>=15V

## DYNAMIC ELECTRICAL CHARACTERISTICS (T<sub>amb</sub> = 25°C, C<sub>L</sub> = 50pF, R<sub>L</sub> = 200KΩ, t<sub>r</sub> = t<sub>f</sub> = 20 ns)

Symbol	Parameter	Test Condition				Value (*)			Unit
		V <sub>EE</sub> (V)	V <sub>SS</sub> (V)	V <sub>DD</sub> (V)		Min.	Typ.	Max.	
t <sub>PHL</sub> t <sub>PLH</sub>	Propagation Delay Time (any Input to any Output)	-5	0	5			650	1300	ns
		0	0	10			575	1150	
		0	0	15			375	750	
t <sub>THL</sub> t <sub>TLH</sub>	Transition Time (any Output)	-5	0	5			100	200	ns
		0	0	10			100	200	
		0	0	15			75	150	

(\*) Typical temperature coefficient for all V<sub>DD</sub> value is 0.3 %/°C.

TYPICAL APPLICATIONS

FIGURE 1 : Display Driver Circuit

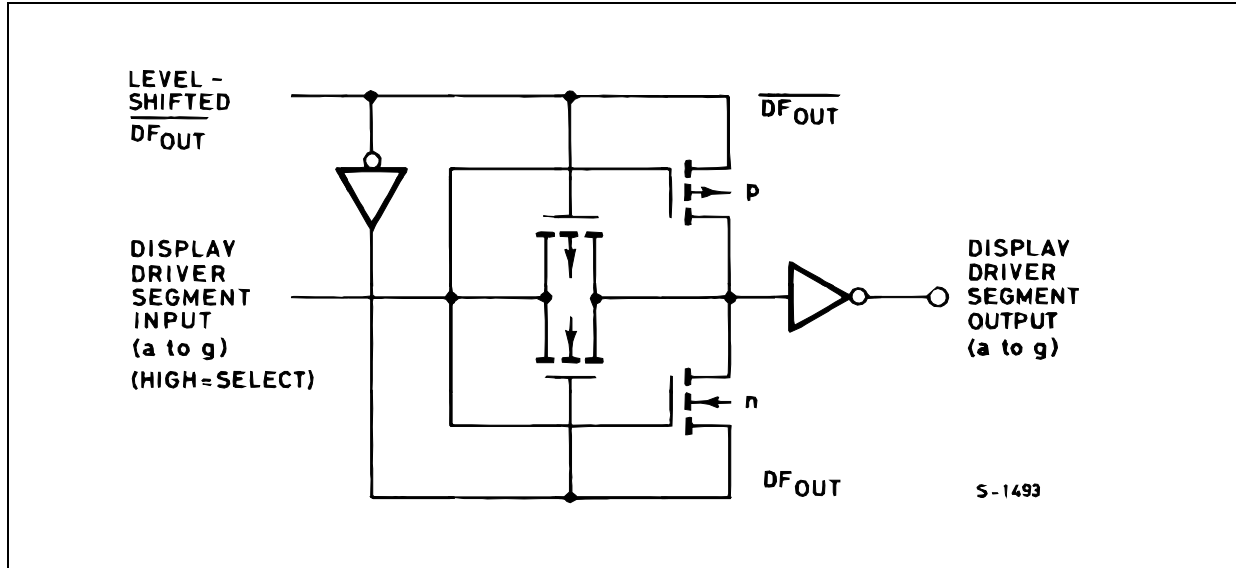
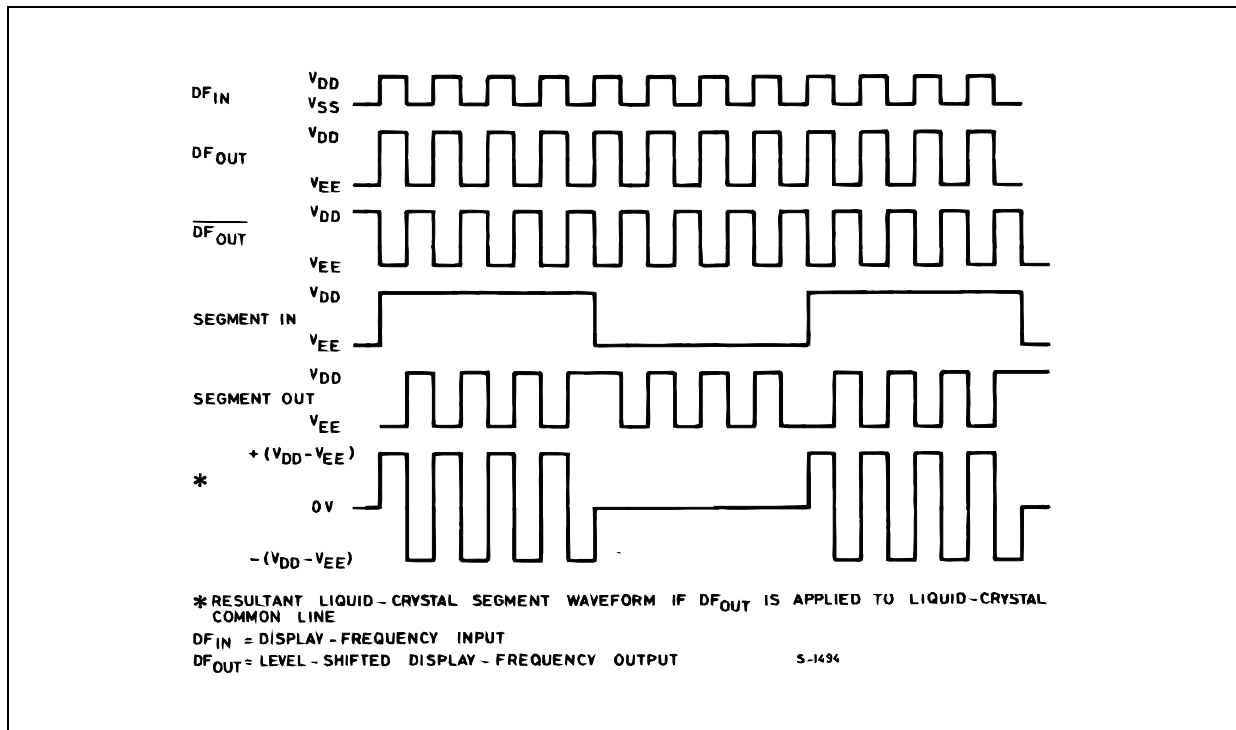
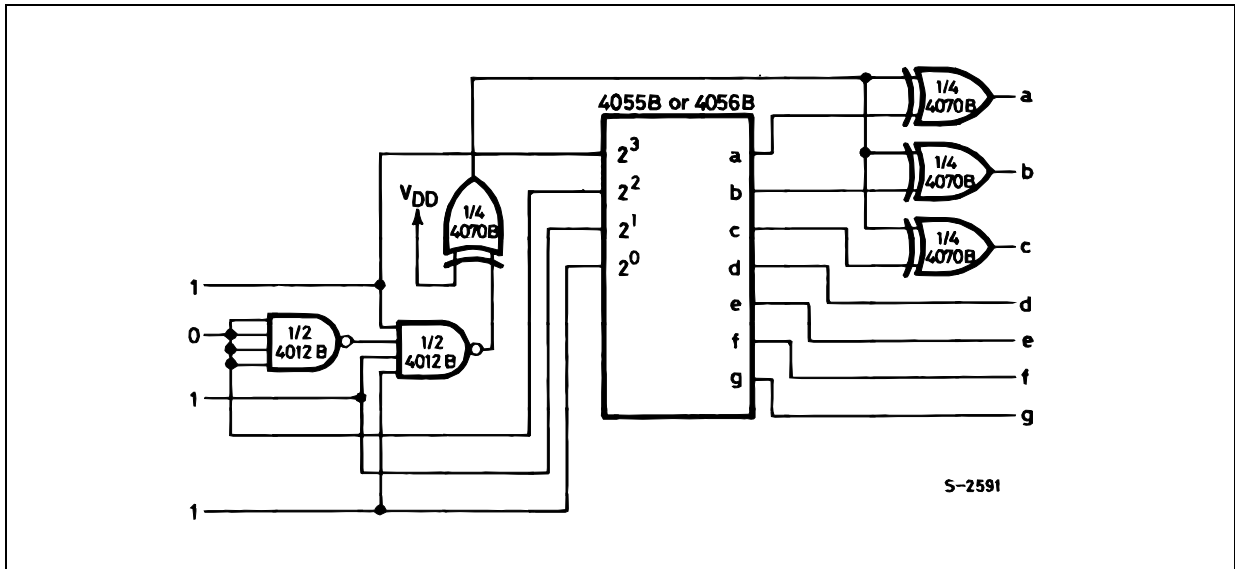

FIGURE 2 : Display Driver Waveforms.



## HCF4056B

**FIGURE 3 :** Conversion Of "H" Display To "F" Display



Example of a circuit that converts an "H" display (code 1011) to an "F" display.

## TEST CIRCUIT

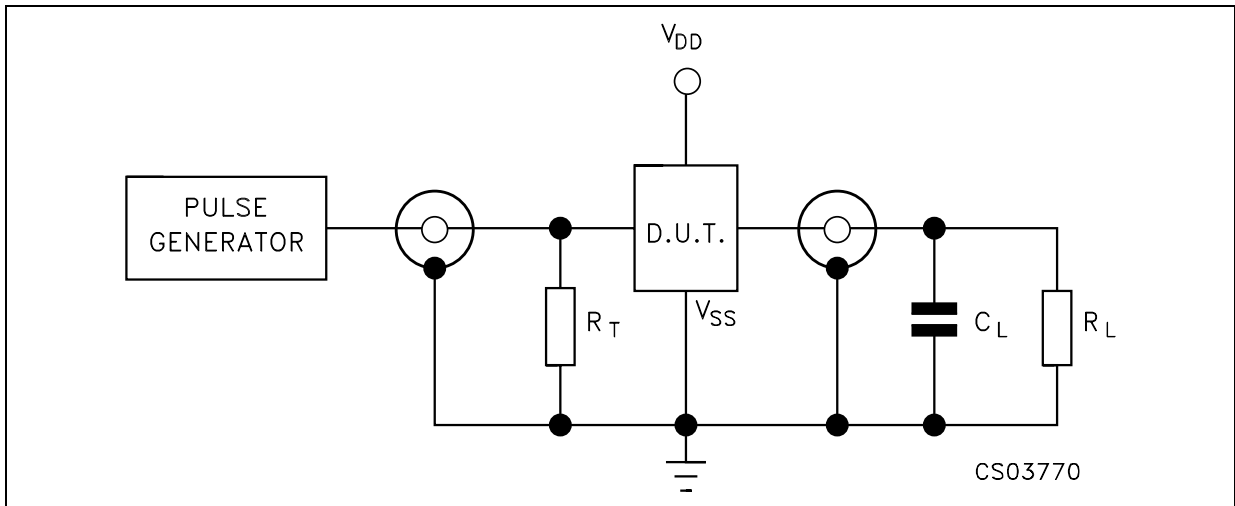

$C_L = 50\text{pF}$  or equivalent (includes jig and probe capacitance)

$R_L = 200\text{K}\Omega$

$R_T = Z_{\text{OUT}}$  of pulse generator (typically  $50\Omega$ )

WAVEFORM : DATA SETUP TIME AND STROBE PULSE DURATION (f=1MHz; 50% duty cycle )

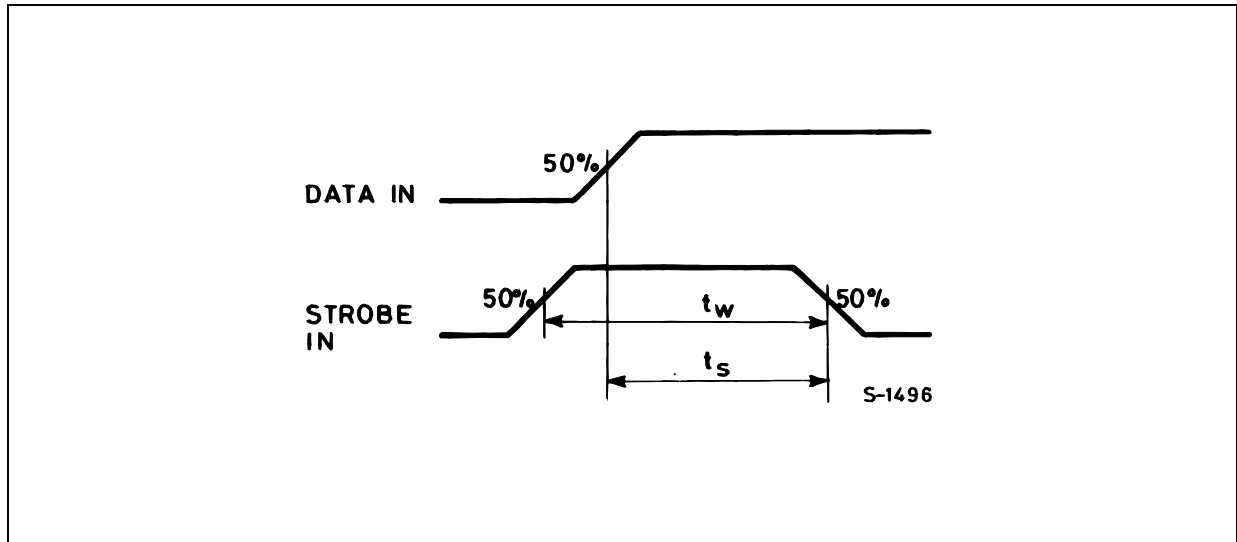

**Plastic DIP-16 (0.25) MECHANICAL DATA**

DIM.	mm.			inch		
	MIN.	TYP.	MAX.	MIN.	TYP.	MAX.
a1	0.51			0.020		
B	0.77		1.65	0.030		0.065
b		0.5			0.020	
b1		0.25			0.010	
D			20			0.787
E		8.5			0.335	
e		2.54			0.100	
e3		17.78			0.700	
F			7.1			0.280
l			5.1			0.201
L		3.3			0.130	
Z			1.27			0.050

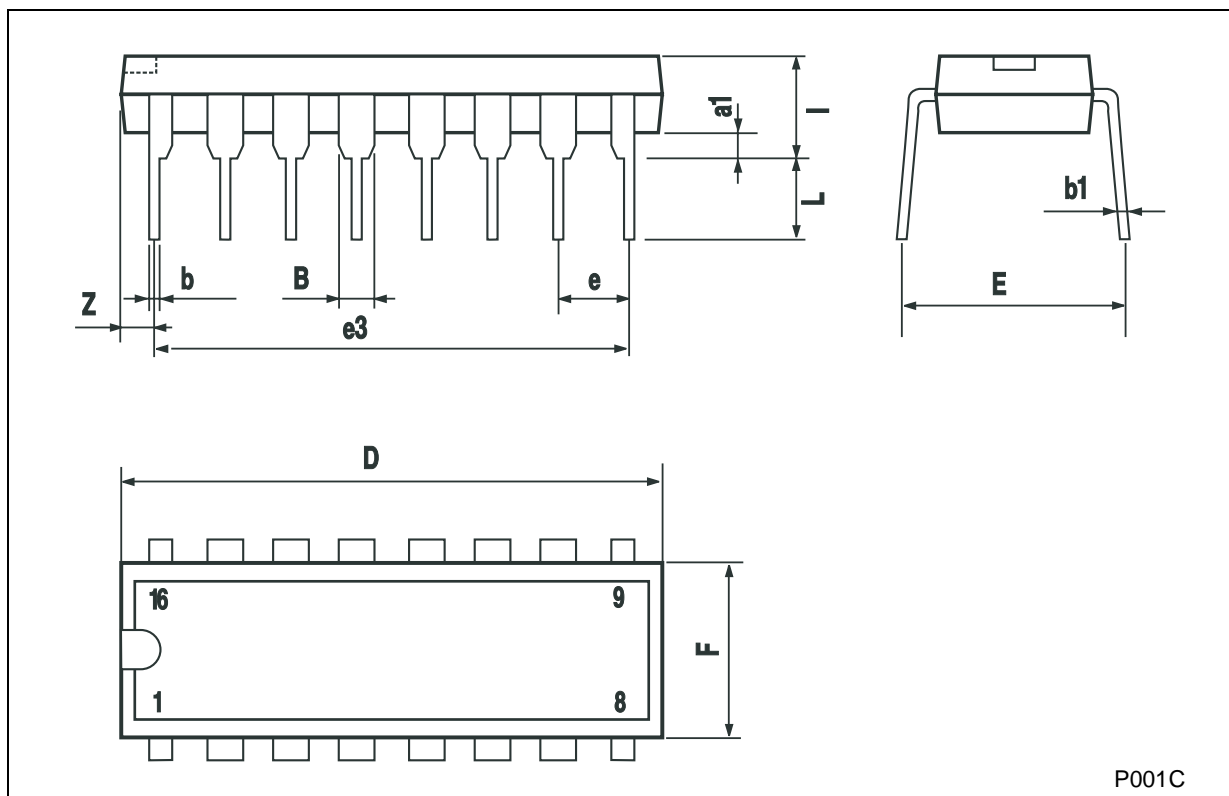



**SO-16 MECHANICAL DATA**

DIM.	mm.			inch		
	MIN.	TYP	MAX.	MIN.	TYP.	MAX.
A			1.75			0.068
a1	0.1		0.2	0.003		0.007
a2			1.65			0.064
b	0.35		0.46	0.013		0.018
b1	0.19		0.25	0.007		0.010
C		0.5			0.019	
c1	45° (typ.)					
D	9.8		10	0.385		0.393
E	5.8		6.2	0.228		0.244
e		1.27			0.050	
e3		8.89			0.350	
F	3.8		4.0	0.149		0.157
G	4.6		5.3	0.181		0.208
L	0.5		1.27	0.019		0.050
M			0.62			0.024
S	8° (max.)					

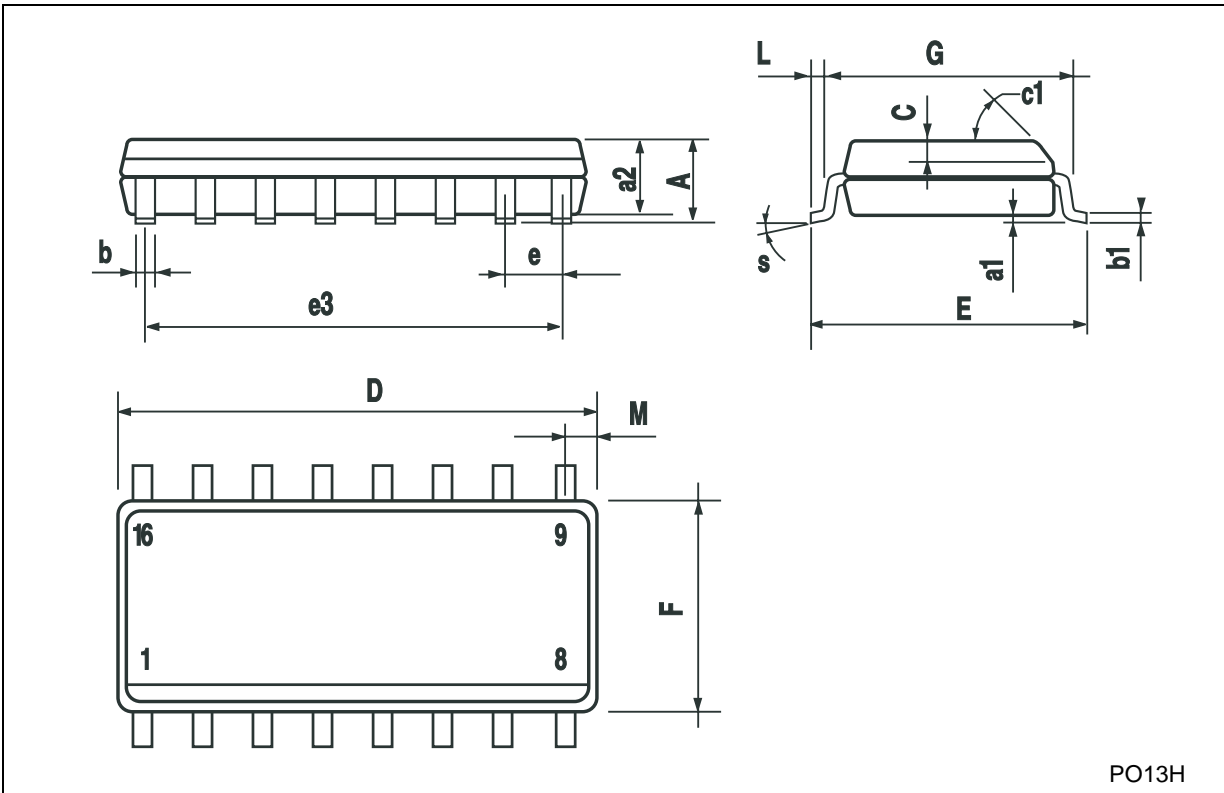

PO13H

Information furnished is believed to be accurate and reliable. However, STMicroelectronics assumes no responsibility for the consequences of use of such information nor for any infringement of patents or other rights of third parties which may result from its use. No license is granted by implication or otherwise under any patent or patent rights of STMicroelectronics. Specifications mentioned in this publication are subject to change without notice. This publication supersedes and replaces all information previously supplied. STMicroelectronics products are not authorized for use as critical components in life support devices or systems without express written approval of STMicroelectronics.

© The ST logo is a registered trademark of STMicroelectronics

© 2002 STMicroelectronics - Printed in Italy - All Rights Reserved  
STMicroelectronics GROUP OF COMPANIES

Australia - Brazil - Canada - China - Finland - France - Germany - Hong Kong - India - Israel - Italy - Japan - Malaysia - Malta - Morocco  
Singapore - Spain - Sweden - Switzerland - United Kingdom - United States.

© <http://www.st.com>