

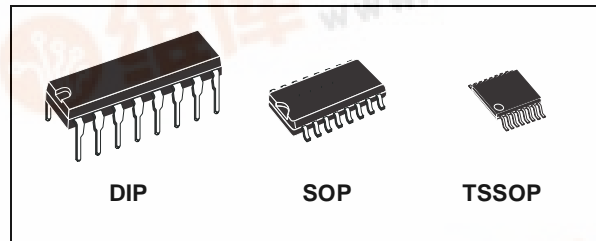

M74HC390

DUAL DECADE COUNTER

- HIGH SPEED :
 $f_{MAX} = 79 \text{ MHz (TYP.) at } V_{CC} = 6\text{V}$
- LOW POWER DISSIPATION:
 $I_{CC} = 4\mu\text{A (MAX.) at } T_A = 25^\circ\text{C}$
- HIGH NOISE IMMUNITY:
 $V_{NIH} = V_{NIL} = 28\% V_{CC} \text{ (MIN.)}$
- SYMMETRICAL OUTPUT IMPEDANCE:
 $|I_{OH}| = I_{OL} = 4\text{mA (MIN.)}$
- BALANCED PROPAGATION DELAYS:
 $t_{PLH} \cong t_{PHL}$
- WIDE OPERATING VOLTAGE RANGE:
 $V_{CC} \text{ (OPR)} = 2\text{V to } 6\text{V}$
- PIN AND FUNCTION COMPATIBLE WITH
 74 SERIES 390



ORDER CODES

PACKAGE	TUBE	T & R
DIP	M74HC390B1R	
SOP	M74HC390M1R	M74HC390RM13TR
TSSOP		M74HC390TTR

DESCRIPTION

The M74HC390 is an high speed CMOS DUAL DECADE COUNTER fabricated with silicon gate C²MOS technology.

This dual decade counter contains two independent ripple carry counters. Each counter is composed of a divide by two and divide by five counter. The divide by two and divide by five counters can be cascaded to form dual decade, dual biquinary, or various combination up to a single divide by 100 counter.

Each 4-bit counter is incremented on the high to low transition (negative edge) of the clock input, and each has an independent clear input. When clear is set low all four bits of each counter are set to low. This enables count truncation and allows the implementation of divide by N counter configuration.

All inputs are equipped with protection circuits against static discharge and transient excess voltage.

PIN CONNECTION AND IEC LOGIC SYMBOLS

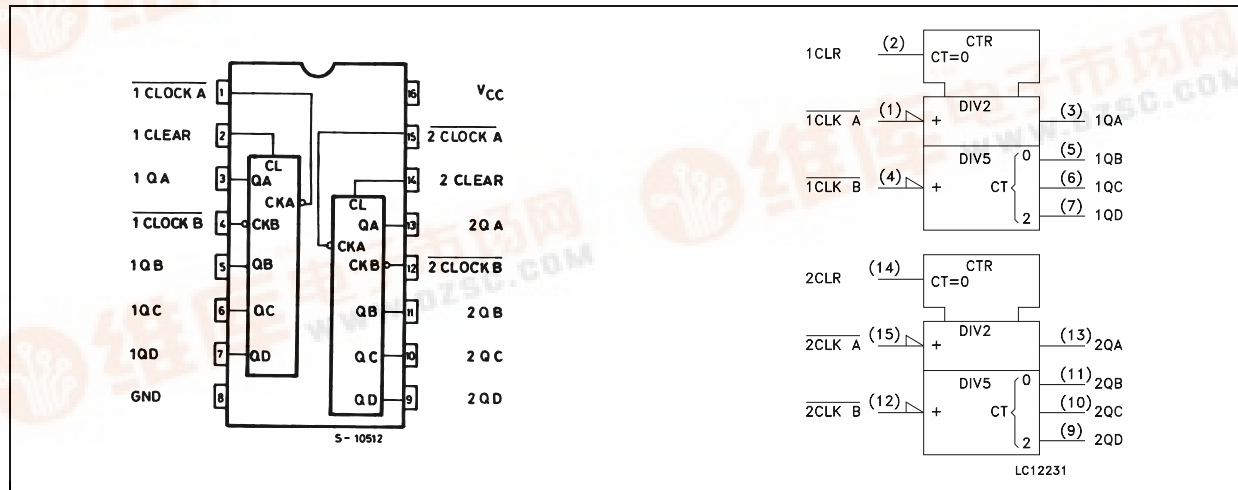

M74HC390

INPUT AND OUTPUT EQUIVALENT CIRCUIT

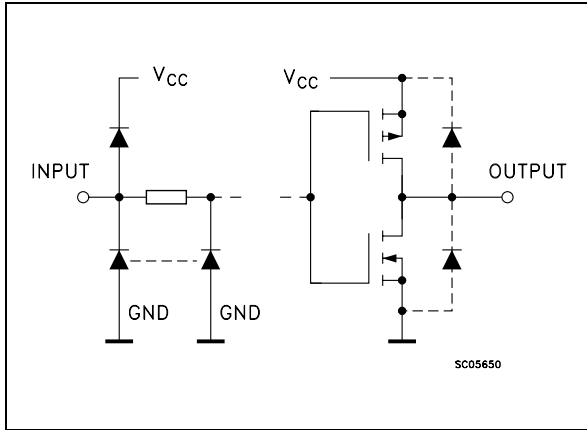

PIN DESCRIPTION

PIN No	SYMBOL	NAME AND FUNCTION
1, 15	$\overline{1}$ CLOCK A $\overline{2}$ CLOCK B	Clock Input Divide by 2 Section (HIGH to LOW Edge-Triggered)
2, 14	1 CLEAR 2 CLEAR	Asynchronous Master Reset Inputs
3, 5, 6, 7	1QA to 1QD	Flip Flop Outputs
4, 12	$\overline{1}$ CLOCK A $\overline{2}$ CLOCK B	Clock Input Divide by 5 Section (HIGH to LOW Edge-Triggered)
13, 11, 10, 9	2QA to 2QD	Flip Flop Outputs
8	GND	Ground (0V)
16	Vcc	Positive Supply Voltage

TRUTH TABLE

COUNT	OUTPUTS							
	BCD COUNT*				BI-QUINARY**			
	QD	QC	QB	QA	QA	QD	QC	QB
0	L	L	L	L	L	L	L	L
1	L	L	L	H	L	L	L	H
2	L	L	H	L	L	L	H	L
3	L	L	H	H	L	L	H	H
4	L	H	L	L	L	H	L	L
5	L	H	L	H	H	H	L	L
6	L	H	H	L	H	L	L	H
7	L	H	H	H	H	L	H	L
8	H	L	L	L	H	L	H	H
9	H	L	L	H	H	H	L	L

INPUTS			OUTPUTS			
$\overline{\text{CLOCK A}}$	$\overline{\text{CLOCK B}}$	CLEAR	QA	QB	QC	QD
X	X	H	L	L	L	L
$\overline{\text{L}}$	X	L	BINARY COUNT UP			
X	$\overline{\text{L}}$	L	QUINARY COUNT UP			

* : Output QA is connected to input $\overline{\text{CLOCK B}}$ for BCD count.

** : Output QD is connected to input $\overline{\text{CLOCK A}}$ for bi-quinary count.

BLOCK DIAGRAM

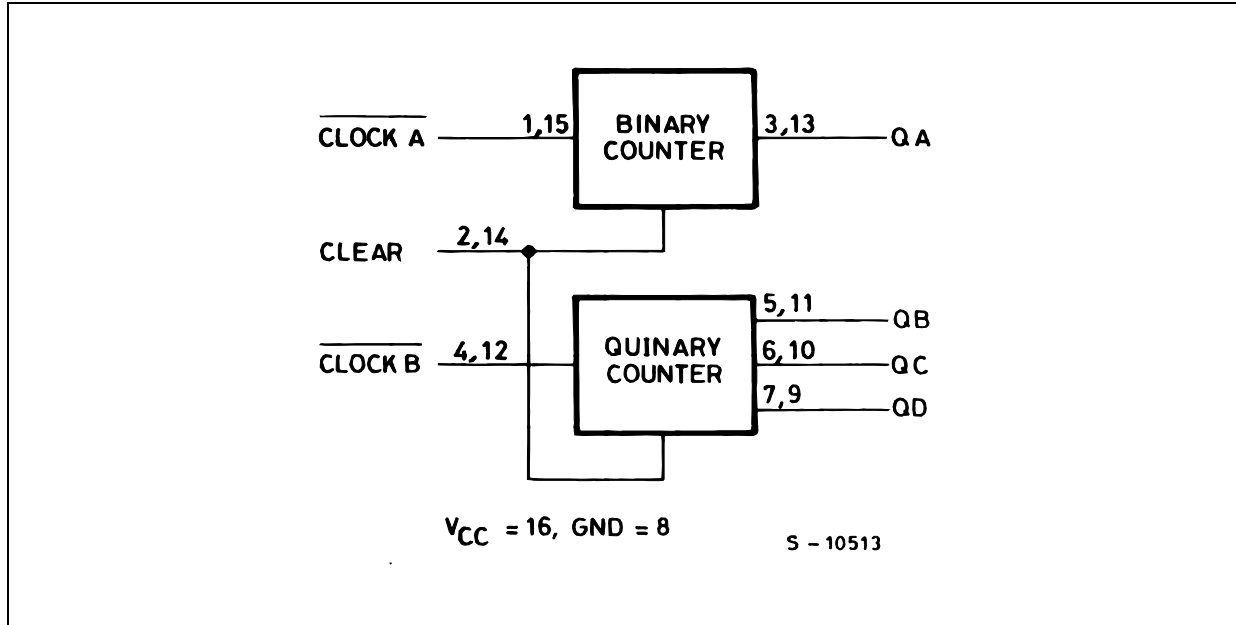

LOGIC DIAGRAM

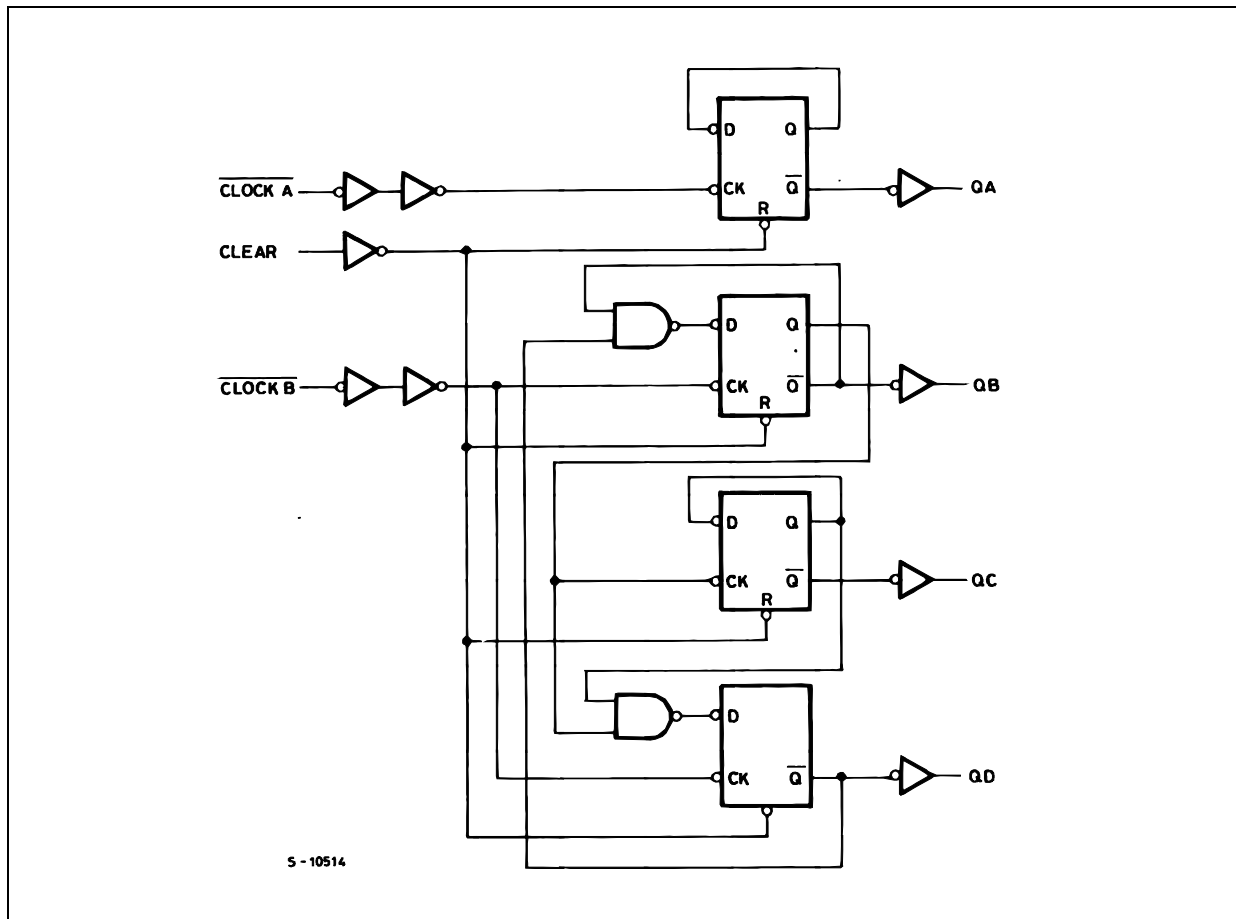

This logic diagram has not been used to estimate propagation delays

M74HC390

TIMING CHART

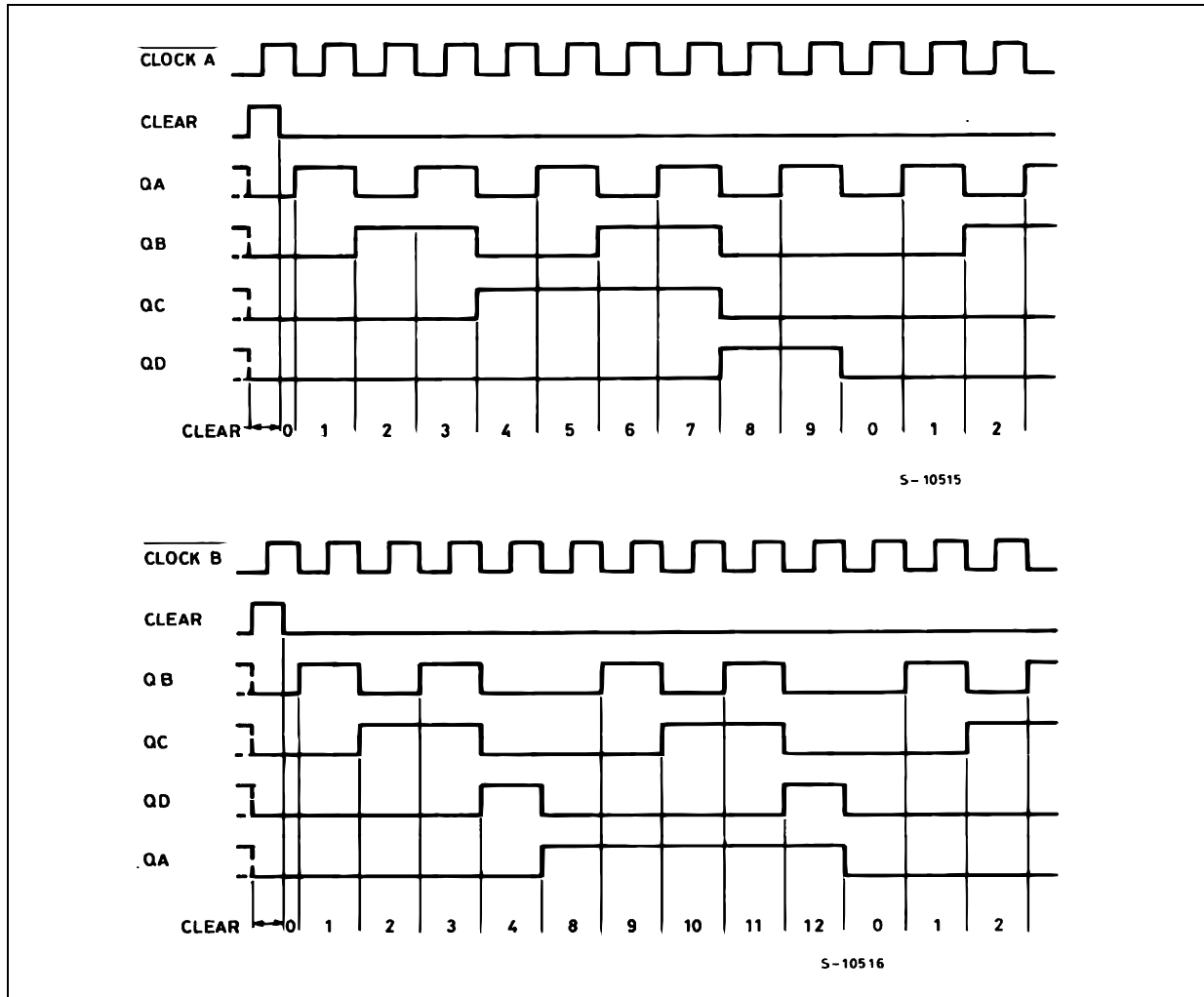

ABSOLUTE MAXIMUM RATINGS

Symbol	Parameter	Value	Unit
V_{CC}	Supply Voltage	-0.5 to +7	V
V_I	DC Input Voltage	-0.5 to $V_{CC} + 0.5$	V
V_O	DC Output Voltage	-0.5 to $V_{CC} + 0.5$	V
I_{IK}	DC Input Diode Current	± 20	mA
I_{OK}	DC Output Diode Current	± 20	mA
I_O	DC Output Current	± 25	mA
I_{CC} or I_{GND}	DC V_{CC} or Ground Current	± 50	mA
P_D	Power Dissipation	500(*)	mW
T_{stg}	Storage Temperature	-65 to +150	$^{\circ}C$
T_L	Lead Temperature (10 sec)	300	$^{\circ}C$

Absolute Maximum Ratings are those values beyond which damage to the device may occur. Functional operation under these conditions is not implied.

(*) 500mW at 65 $^{\circ}C$; derate to 300mW by 10mW/ $^{\circ}C$ from 65 $^{\circ}C$ to 85 $^{\circ}C$

RECOMMENDED OPERATING CONDITIONS

Symbol	Parameter	Value	Unit	
V_{CC}	Supply Voltage	2 to 6	V	
V_I	Input Voltage	0 to V_{CC}	V	
V_O	Output Voltage	0 to V_{CC}	V	
T_{op}	Operating Temperature	-55 to 125	°C	
t_r, t_f	Input Rise and Fall Time	$V_{CC} = 2.0V$	0 to 1000	ns
		$V_{CC} = 4.5V$	0 to 500	ns
		$V_{CC} = 6.0V$	0 to 400	ns

DC SPECIFICATIONS

Symbol	Parameter	Test Condition		Value						Unit	
		V_{CC} (V)		$T_A = 25^\circ\text{C}$			-40 to 85°C		-55 to 125°C		
				Min.	Typ.	Max.	Min.	Max.	Min.		Max.
V_{IH}	High Level Input Voltage	2.0		1.5			1.5		1.5		V
		4.5		3.15			3.15		3.15		
		6.0		4.2			4.2		4.2		
V_{IL}	Low Level Input Voltage	2.0				0.5		0.5		0.5	V
		4.5				1.35		1.35		1.35	
		6.0				1.8		1.8		1.8	
V_{OH}	High Level Output Voltage	2.0	$I_O = -20 \mu\text{A}$	1.9	2.0		1.9		1.9		V
		4.5	$I_O = -20 \mu\text{A}$	4.4	4.5		4.4		4.4		
		6.0	$I_O = -20 \mu\text{A}$	5.9	6.0		5.9		5.9		
		4.5	$I_O = -4.0 \text{ mA}$	4.18	4.31		4.13		4.10		
		6.0	$I_O = -5.2 \text{ mA}$	5.68	5.8		5.63		5.60		
V_{OL}	Low Level Output Voltage	2.0	$I_O = 20 \mu\text{A}$		0.0	0.1		0.1		0.1	V
		4.5	$I_O = 20 \mu\text{A}$		0.0	0.1		0.1		0.1	
		6.0	$I_O = 20 \mu\text{A}$		0.0	0.1		0.1		0.1	
		4.5	$I_O = 4.0 \text{ mA}$		0.17	0.26		0.33		0.40	
		6.0	$I_O = 5.2 \text{ mA}$		0.18	0.26		0.33		0.40	
I_I	Input Leakage Current	6.0	$V_I = V_{CC}$ or GND			± 0.1		± 1		± 1	μA
I_{CC}	Quiescent Supply Current	6.0	$V_I = V_{CC}$ or GND			4		40		80	μA

M74HC390

AC ELECTRICAL CHARACTERISTICS ($C_L = 50$ pF, Input $t_r = t_f = 6$ ns)

Symbol	Parameter	Test Condition		Value						Unit	
		V_{CC} (V)		$T_A = 25^\circ\text{C}$			-40 to 85°C		-55 to 125°C		
				Min.	Typ.	Max.	Min.	Max.	Min.		Max.
t_{TLH} t_{THL}	Output Transition Time	2.0			30	75		95		110	ns
		4.5			8	15		19		22	
		6.0			7	13		16		19	
t_{PLH} t_{PHL}	Propagation Delay Time (CLOCK A - QA)	2.0			42	120		150		180	ns
		4.5			14	24		30		36	
		6.0			12	20		26		31	
t_{PLH} t_{PHL}	Propagation Delay Time (CLOCK A-QB,QD)	2.0			45	120		150		180	ns
		4.5			15	24		30		36	
		6.0			13	20		26		31	
t_{PLH} t_{PHL}	Propagation Delay Time (CLOCK A - QC)	2.0	QA Connected to CKB		108	280		350		420	ns
		4.5			36	56		70		84	
		6.0			31	48		60		71	
t_{PLH} t_{PHL}	Propagation Delay Time (CLOCK B - QC)	2.0			72	185		230		280	ns
		4.5			24	37		46		56	
		6.0			20	31		39		48	
t_{PHL}	Propagation Delay Time (CLEAR - Qn)	2.0			45	125		155		190	ns
		4.5			15	25		31		38	
		6.0			13	21		26		32	
f_{MAX}	Maximum Clock Frequency (CLOCK A - QA)	2.0			8.4	17		6.8		5.6	MHz
		4.5			42	65		34		28	
		6.0			50	79		40		33	
f_{MAX}	Maximum Clock Frequency (CLOCK B - QB)	2.0			8.4	17		6.8		5.6	MHz
		4.5			42	67		34		28	
		6.0			50	79		40		33	
$t_{W(H)}$ $t_{W(L)}$	Minimum Pulse Width (CLOCK)	2.0			24	75		95		110	ns
		4.5			6	15		19		22	
		6.0			5	13		16		19	
$t_{W(H)}$	Minimum Pulse Width (CLEAR)	2.0			24	75		95		110	ns
		4.5			6	15		19		22	
		6.0			5	13		16		19	
t_{REM}	Minimum Removal Time	2.0				25		30		35	ns
		4.5				5		6		7	
		6.0				5		5		6	

CAPACITIVE CHARACTERISTICS

Symbol	Parameter	Test Condition		Value						Unit	
		V_{CC} (V)		$T_A = 25^\circ\text{C}$			-40 to 85°C		-55 to 125°C		
				Min.	Typ.	Max.	Min.	Max.	Min.		Max.
C_{IN}	Input Capacitance				5	10		10		10	pF
C_{PD}	Power Dissipation Capacitance (note 1)				84						pF

1) C_{PD} is defined as the value of the IC's internal equivalent capacitance which is calculated from the operating current consumption without load. (Refer to Test Circuit). Average operating current can be obtained by the following equation. $I_{CC(opr)} = C_{PD} \times V_{CC} \times f_{IN} + I_{CC}$

TEST CIRCUIT

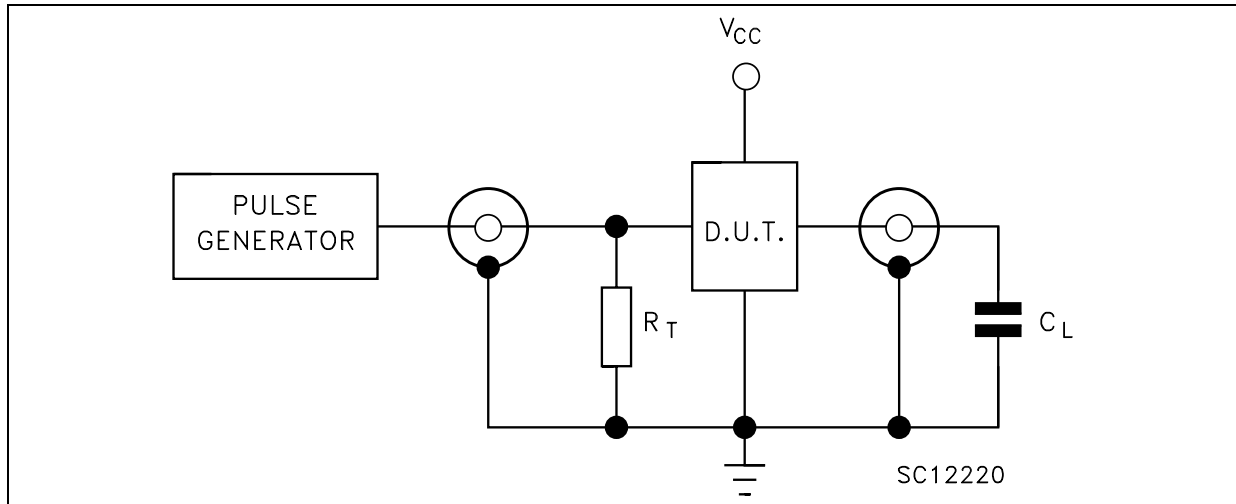

$C_L = 50\text{pF}$ or equivalent (includes jig and probe capacitance)
 $R_T = Z_{OUT}$ of pulse generator (typically 50Ω)

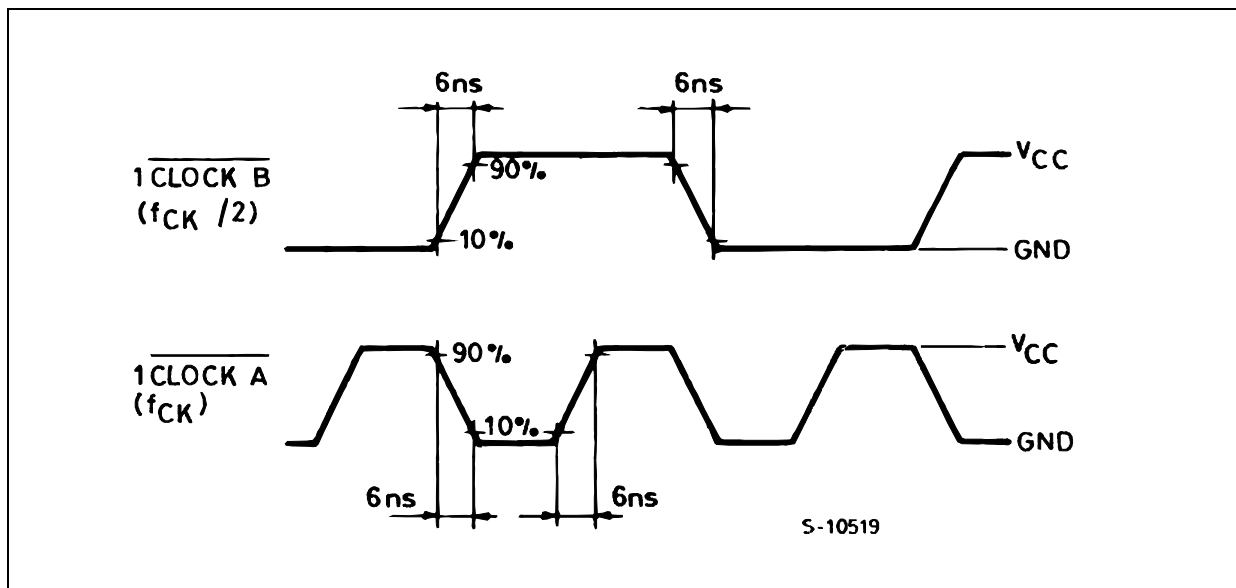
WAVEFORM 1: CLOCK WAVEFORM ($f=1\text{MHz}$; 50% duty cycle)

M74HC390

WAVEFORM 2 :PROPAGATION DELAY TIMES, MINIMUM PULSE WIDTH AND REMOVAL TIME
 (f=1MHz; 50% duty cycle)

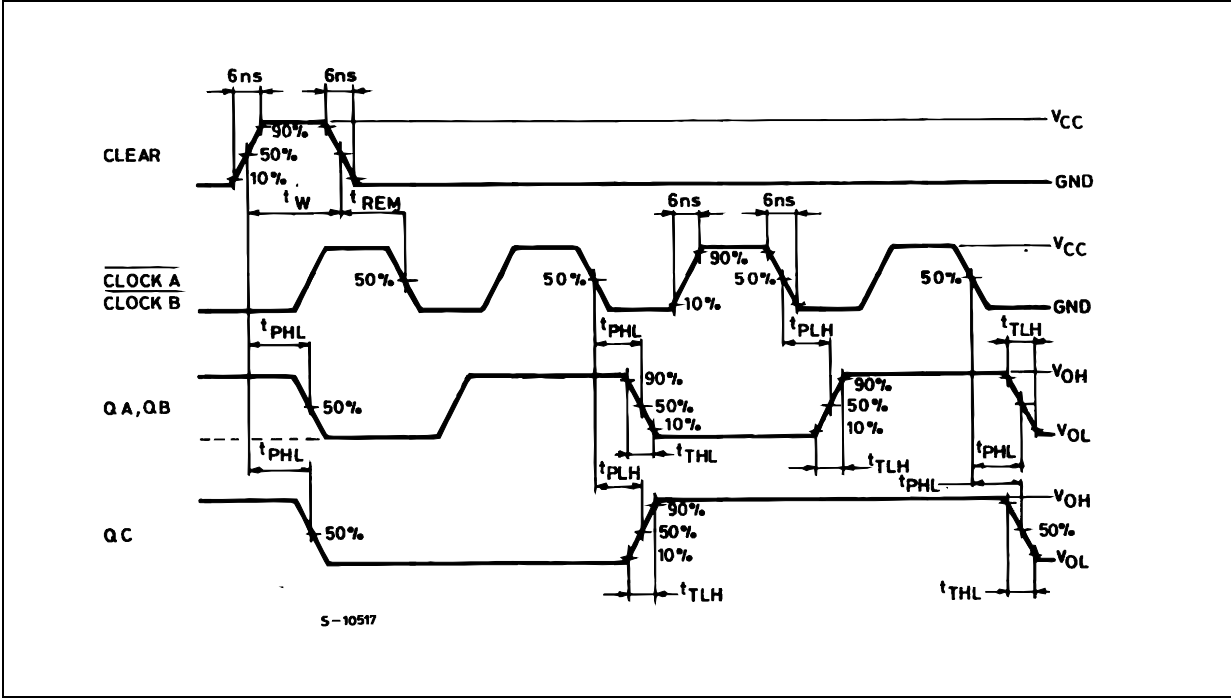

Plastic DIP-16 (0.25) MECHANICAL DATA

DIM.	mm.			inch		
	MIN.	TYP.	MAX.	MIN.	TYP.	MAX.
a1	0.51			0.020		
B	0.77		1.65	0.030		0.065
b		0.5			0.020	
b1		0.25			0.010	
D			20			0.787
E		8.5			0.335	
e		2.54			0.100	
e3		17.78			0.700	
F			7.1			0.280
I			5.1			0.201
L		3.3			0.130	
Z			1.27			0.050

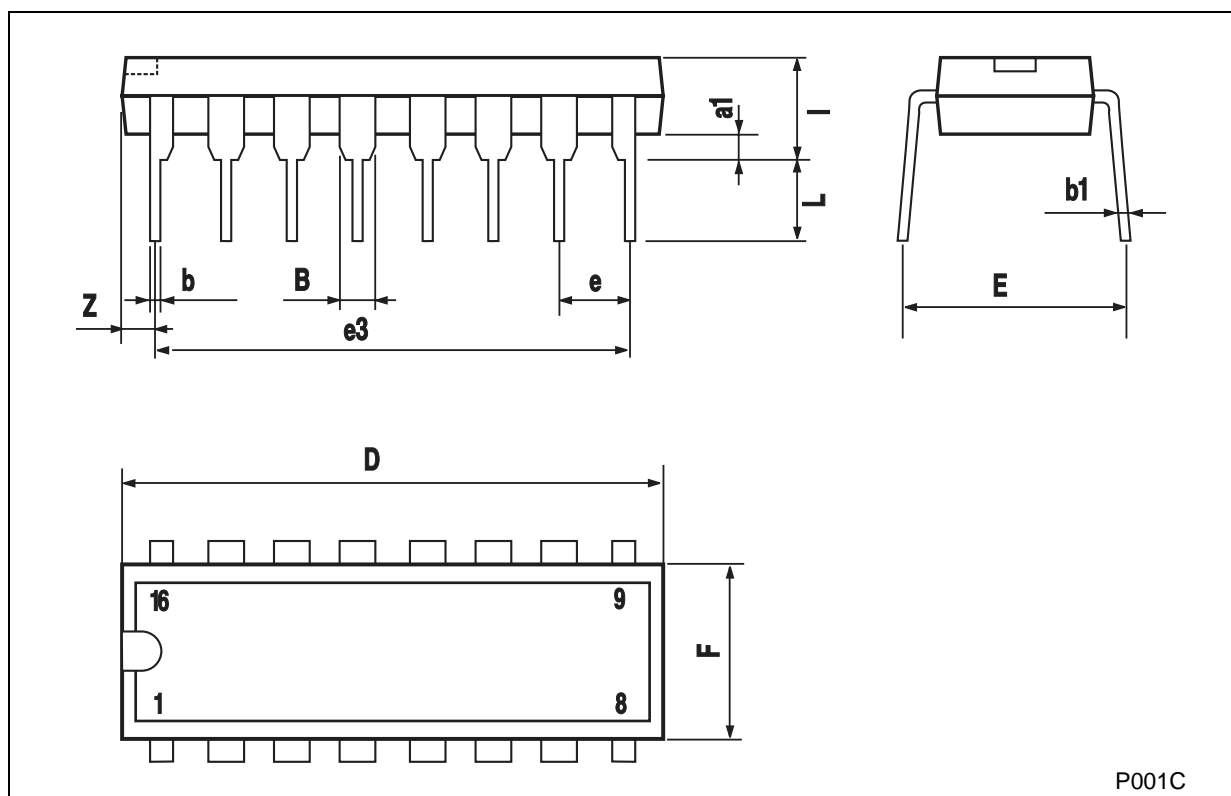

SO-16 MECHANICAL DATA

DIM.	mm.			inch		
	MIN.	TYP	MAX.	MIN.	TYP.	MAX.
A			1.75			0.068
a1	0.1		0.2	0.003		0.007
a2			1.65			0.064
b	0.35		0.46	0.013		0.018
b1	0.19		0.25	0.007		0.010
C		0.5			0.019	
c1	45° (typ.)					
D	9.8		10	0.385		0.393
E	5.8		6.2	0.228		0.244
e		1.27			0.050	
e3		8.89			0.350	
F	3.8		4.0	0.149		0.157
G	4.6		5.3	0.181		0.208
L	0.5		1.27	0.019		0.050
M			0.62			0.024
S	8° (max.)					

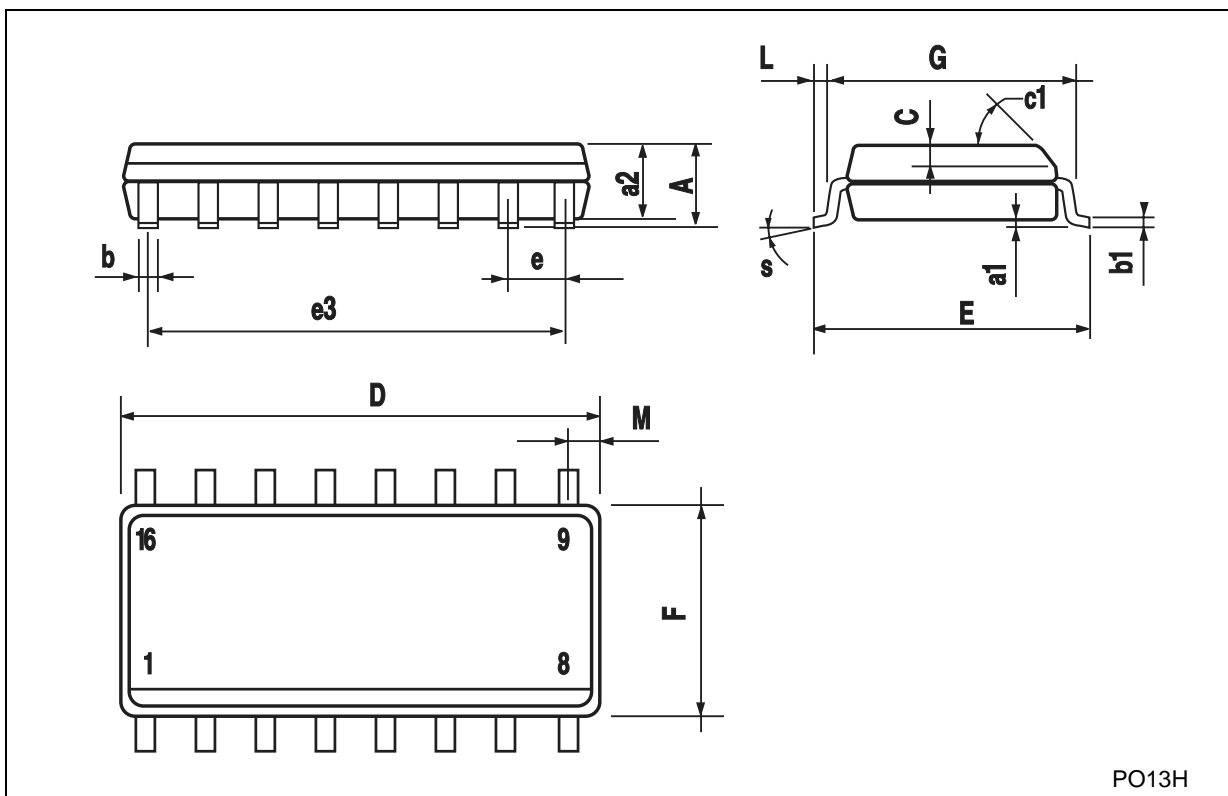

PO13H

TSSOP16 MECHANICAL DATA

DIM.	mm.			inch		
	MIN.	TYP	MAX.	MIN.	TYP.	MAX.
A			1.2			0.047
A1	0.05		0.15	0.002	0.004	0.006
A2	0.8	1	1.05	0.031	0.039	0.041
b	0.19		0.30	0.007		0.012
c	0.09		0.20	0.004		0.0089
D	4.9	5	5.1	0.193	0.197	0.201
E	6.2	6.4	6.6	0.244	0.252	0.260
E1	4.3	4.4	4.48	0.169	0.173	0.176
e		0.65 BSC			0.0256 BSC	
K	0°		8°	0°		8°
L	0.45	0.60	0.75	0.018	0.024	0.030

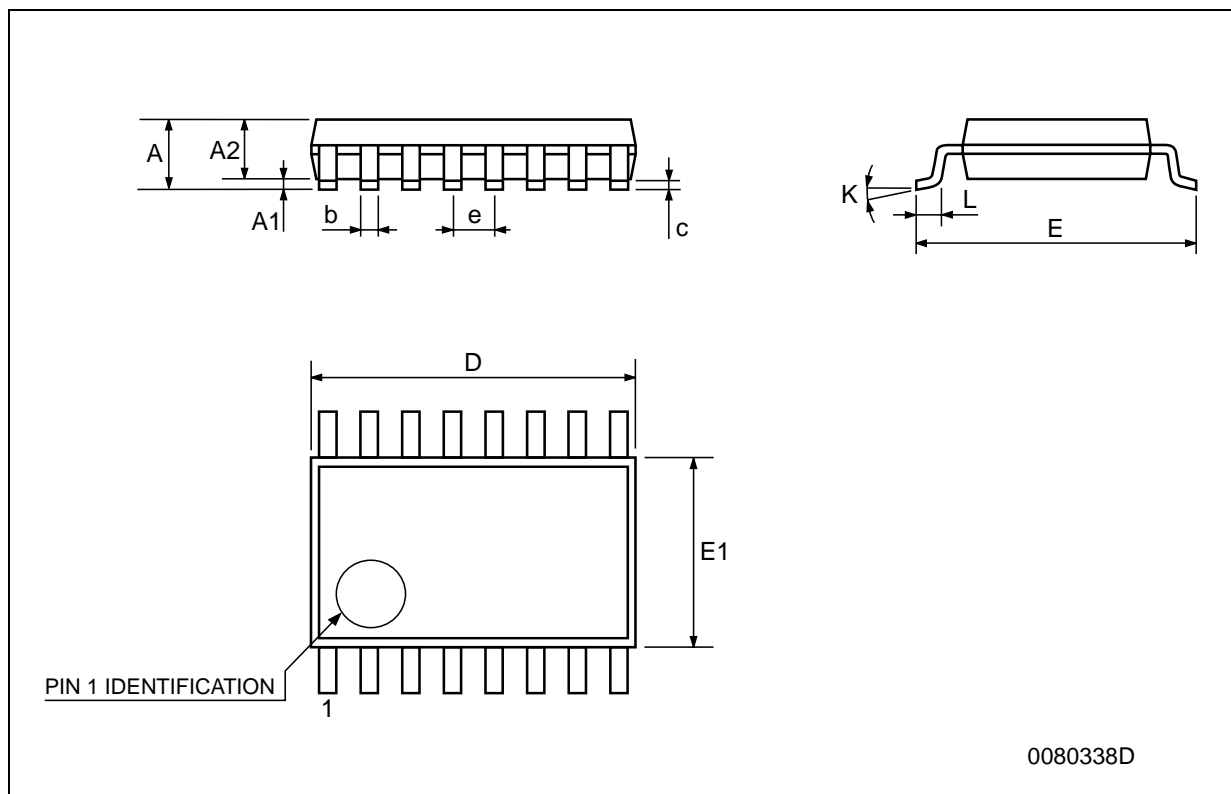

Information furnished is believed to be accurate and reliable. However, STMicroelectronics assumes no responsibility for the consequences of use of such information nor for any infringement of patents or other rights of third parties which may result from its use. No license is granted by implication or otherwise under any patent or patent rights of STMicroelectronics. Specifications mentioned in this publication are subject to change without notice. This publication supersedes and replaces all information previously supplied. STMicroelectronics products are not authorized for use as critical components in life support devices or systems without express written approval of STMicroelectronics.

© The ST logo is a registered trademark of STMicroelectronics

© 2001 STMicroelectronics - Printed in Italy - All Rights Reserved
STMicroelectronics GROUP OF COMPANIES

Australia - Brazil - China - Finland - France - Germany - Hong Kong - India - Italy - Japan - Malaysia - Malta - Morocco
Singapore - Spain - Sweden - Switzerland - United Kingdom

© <http://www.st.com>