

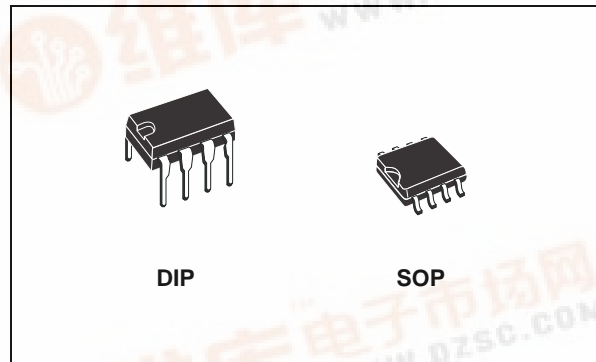

ST485A

VERY HIGH SPEED LOW POWER RS-485/RS-422 TRANSCEIVER

- LOW SUPPLY CURRENT: 5mA MAX
- HIGH DATA RATE > 30Mbps
- DESIGNED FOR RS 485 INTERFACE APPLICATIONS
- -7 TO 12 COMMON MODE INPUT VOLTAGE RANGE
- DRIVER MANTAINS HIGH IMPEDANCE IN 3-STATE OR WITH THE POWER OFF
- 70mV TYPICAL INPUT HYSTERESIS
- OPERATE FROM SINGLE 5 SUPPLY
- ±4kV ESD PROTECTION
- CURRENT LIMITING AND THERMAL SHUTDOWN FOR DRIVER OVERLOAD PROTECTION
- LATCH-UP FREE UP TO 500mA



DESCRIPTION

The ST485A is a low power, high speed transceiver for RS-485 and RS-422 communications. The device contains one driver and one receiver in half duplex configuration. The ST485A draws 3mA (typ.) of supply current when

unloaded or fully loaded with disabled drivers. It operates from a single 5V supply.

Driver is short-circuit current limited and is protected against excessive power dissipation by thermal shutdown circuitry that place the driver outputs into a high-impedance state. The receiver input has a fail-safe feature that guarantees a logic high output if both inputs are open circuit.

The ST485A is designed for bi-directional data communications or multipoint bus transmission lines.

ORDERING CODES

| Type | Temperature Range | Package | Comments |
|-----------|-------------------|--------------------|------------------------------------|
| ST485ACN | 0 to 70 °C | DIP-8 | 50parts per tube / 40tube per box |
| ST485ABN | -40 to 85 °C | DIP-8 | 50parts per tube / 40tube per box |
| ST485ACD | 0 to 70 °C | SO-8 (Tube) | 100parts per tube / 20tube per box |
| ST485ABD | -40 to 85 °C | SO-8 (Tube) | 100parts per tube / 20tube per box |
| ST485ACDR | 0 to 70 °C | SO-8 (Tape & Reel) | 2500 parts per reel |
| ST485ABDR | -40 to 85 °C | SO-8 (Tape & Reel) | 2500 parts per reel |

ST485A

PIN CONFIGURATION

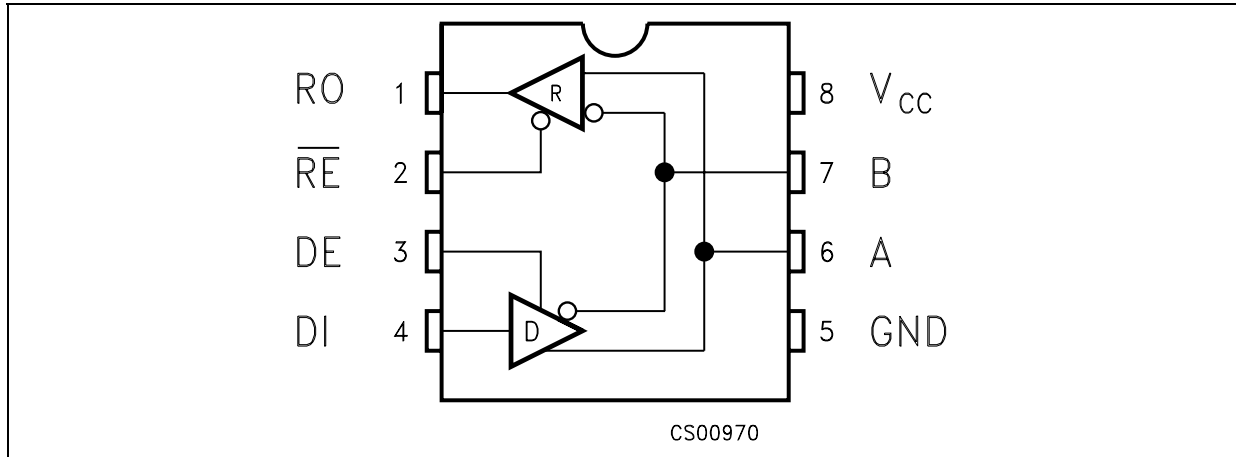

PIN DESCRIPTION

| PIN N° | SYMBOL | NAME AND FUNCTION |
|--------|-----------------|---|
| 1 | RO | Receiver Output. If A>B by 200mV, RO will be high; if A<B by 200mV, RO will be low |
| 2 | \overline{RE} | Receiver Output Enable. RO is enabled when RE is low; RO is high impedance when RE is high. If RE is high and DE is low, the device will enter a low power shutdown mode. |
| 3 | DE | Driver Output Enable. The driver outputs are enabled by bringing DE high. They are high impedance when DE is low. If RE is high DE is low, the device will enter a low-power shutdown mode. If the driver outputs are enabled, the part functions as line driver, while they are high impedance, it functions as line receivers if RE is low. |
| 4 | DI | Driver Input. A low on DI forces output A low and output B high. Similarly, a high on DI forces output A high and output B low |
| 5 | GND | Ground |
| 6 | A | Non-inverting Receiver Input and Non-inverting Driver Output |
| 7 | B | Inverting Receiver Input and Inverting Driver Output |
| 8 | V _{CC} | Supply Voltage: V _{CC} = 4.75V to 5.25V |

TRUTH TABLE (DRIVER)

| INPUTS | | | OUTPUTS | | MODE |
|-----------------|----|----|---------|---|--------|
| \overline{RE} | DE | DI | B | A | |
| X | H | H | L | H | Normal |
| X | H | L | H | L | Normal |
| L | L | X | Z | Z | Normal |

X= Don't Care; Z=High Impedance

TRUTH TABLE (RECEIVER)

| INPUTS | | | OUTPUT | MODE |
|-----------------|----|--------------|--------|--------|
| \overline{RE} | DE | A-B | RO | |
| L | L | $\geq -0.2V$ | H | Normal |
| L | L | $\leq -0.2V$ | L | Normal |
| L | L | Inputs Open | H | Normal |

X= Don't Care; Z=High Impedance

ABSOLUTE MAXIMUM RATINGS

| Symbol | Parameter | Value | Unit |
|----------|--------------------------------|----------------------------|------|
| V_{CC} | Supply Voltage | 7 | V |
| V_I | Control Input Voltage (RE, DE) | -0.3 to 7 | V |
| V_{DI} | Driver Input Voltage (DI) | -0.3 to 7 | V |
| V_{DO} | Driver Output Voltage (A, B) | -7.5 to 12.5 | V |
| V_{RI} | Receiver Input Voltage (A, B) | -7.5 to 12.5 | V |
| V_{RO} | Receiver Output Voltage (RO) | -0.3 to ($V_{CC} + 0.3$) | V |

Absolute Maximum Ratings are those values beyond which damage to the device may occur. Functional operation under these condition is not implied.

ELECTRICAL CHARACTERISTICS

$V_{CC} = 4.5V$ to $5.5V$, $T_A = -40$ to $85^\circ C$, unless otherwise specified. Typical values are referred to $T_A = 25^\circ C$, $V_{CC} = 5V$) (See Note 1)

| Symbol | Parameter | Test Conditions | Min. | Typ. | Max. | Unit | |
|--------------|-------------------------------|----------------------------------|-----------------|------|------|------|----|
| I_{SUPPLY} | V_{CC} Power Supply Current | No Load, $V_{RE}=0V$ or V_{CC} | $V_{DE}=V_{CC}$ | | 2.3 | 5 | mA |
| | | | $V_{DE}=0V$ | | 2.6 | 5 | mA |
| $C_{I/O}$ | Input/Output Capacitance | | | 10 | | pF | |
| C_{AB} | Driver Output Capacity | | | 10 | | pF | |

LOGIC INPUT ELECTRICAL CHARACTERISTICS

$V_{CC} = 4.5V$ to $5.5V$, $T_A = -40$ to $85^\circ C$, unless otherwise specified. Typical values are referred to $T_A = 25^\circ C$, $V_{CC} = 5V$) (See Note 1)

| Symbol | Parameter | Test Conditions | Min. | Typ. | Max. | Unit |
|-----------|----------------------------|--------------------------------------|--------------|------|-----------|---------|
| V_{IL} | Input Logic Threshold Low | DE, DI, RE | | | 0.8 | V |
| V_{IH} | Input Logic Threshold High | DE, DI, RE | 2 | | | V |
| I_{IN1} | Logic Input Current | DE, DI, RE | | | ± 2.0 | μA |
| I_{IN2} | Input Current (A, B) | $V_{DE}=0V$, $V_{CC}= 0$ or $5.25V$ | $V_{IN}=12V$ | | 1 | mA |
| | | | $V_{IN}=-7V$ | | -0.8 | mA |

ST485A

TRANSMITTER ELECTRICAL CHARACTERISTICS

$V_{CC} = 4.5V$ to $5.5V$, $T_A = -40$ to $85^\circ C$, unless otherwise specified. Typical values are referred to $T_a = 25^\circ C$, $V_{CC} = 5V$) (See Note 1)

| Symbol | Parameter | Test Conditions | Min. | Typ. | Max. | Unit |
|-----------------|---|---|------|------|-----------|------|
| V_{OD1} | Differential Driver Output (No load) | | | | 5 | V |
| V_{OD2} | Differential Driver Output (With Load) | $R_L = 54\Omega$ (RS-422) $V_{CM} = -7V$ to $12V$ | 1.5 | 2.7 | 5 | V |
| ΔV_{OD} | Change in magnitude of Driver Differential Output Voltage for Complementary Output States (Note1) | $R_L = 27\Omega$ or 50Ω | | 0 | 0.2 | V |
| V_{OC} | Driver Common Mode Output Voltage | $R_L = 27\Omega$ or 50Ω | 1 | | 3 | V |
| ΔV_{OC} | Change in magnitude of Driver Common Mode Output Voltage (Note1) | $R_L = 54\Omega$ or 100Ω | | 0 | 0.2 | V |
| I_{OSD} | Driver Short Circuit Output Current | $V_O = -7V$ to $12V$ | | | ± 250 | mA |

RECEIVER ELECTRICAL CHARACTERISTICS

$V_{CC} = 4.5V$ to $5.5V$, $T_A = -40$ to $85^\circ C$, unless otherwise specified. Typical values are referred to $T_a = 25^\circ C$, $V_{CC} = 5V$) (See Note 1)

| Symbol | Parameter | Test Conditions | Min. | Typ. | Max. | Unit |
|-----------------|---|-------------------------------------|------|------|---------|-----------|
| V_{TH} | Receiver Differential Threshold Voltage | $V_{CM} = -7V$ to $12V$ | -0.2 | | 0.2 | V |
| ΔV_{TH} | Receiver Input Hysteresis | $V_{CM} = 0V$ | | 70 | | mV |
| V_{OH} | Receiver Output High Voltage | $I_{OUT} = -4mA$, $V_{ID} = 200mV$ | 3.5 | 4.7 | | V |
| V_{OL} | Receiver Output Low Voltage | $I_{OUT} = 4mA$, $V_{ID} = -200mV$ | | 0.2 | 0.4 | V |
| I_{OZR} | 3-State (High Impedance) Output Current at Receiver | $V_O = 0.4V$ to $2.4V$ | | | ± 1 | μA |
| R_{RIN} | Receiver Input Resistance | $V_{CM} = -7V$ to $12V$ | 12 | 24 | | $K\Omega$ |
| I_{OSR} | Receiver Short-Circuit Current | $V_O = 0V$ to V_{CC} | 7 | | 95 | mA |

DRIVER SWITCHING CHARACTERISTICS

$V_{CC} = 4.5V$ to $5.5V$, $T_A = -40$ to $85^\circ C$, unless otherwise specified. Typical values are referred to $T_a = 25^\circ C$, $V_{CC} = 5V$) (See Note 1, 3)

| Symbol | Parameter | Test Conditions | Min. | Typ. | Max. | Unit |
|------------------------|---|--|------|------|------|------|
| D_R | Maximum Data Rate | Jitter <5% | 30 | 50 | | Mbps |
| t_{PLH} t_{PHL} | Propagation Delay Input to Output | $R_L = 54\Omega$ $C_{L1}=C_{L2}=50pF$, (Figure 1) | | 18 | 30 | ns |
| t_{SKEW} | Differential Output Delay Skew | $R_L = 54\Omega$ $C_{L1}=C_{L2}=50pF$, (Figure 1) | | 0.5 | 2 | ns |
| t_{TLH} t_{THL} | Rise or Fall Differential Time | $R_L = 54\Omega$ $C_{L1}=C_{L2}=50pF$, (Figure 1) | | 8 | 12 | ns |
| t_{PZL} | Output Enable Time | $C_L = 50pF$ S1 Closed | | | 30 | ns |
| t_{PZH} | Output Enable Time | $C_L = 50pF$ S2 Closed | | | 30 | ns |
| t_{PHZ} | Output Disable Time | $C_L = 15pF$ S2 Closed | | | 30 | ns |
| t_{PLZ} | Output Disable Time | $C_L = 15pF$ S1 Closed | | | 30 | ns |
| $t_{SK(EN)}$ | Synchronous Driver Operation A-B at Enable | | | | 2 | ns |
| $t_{SK(DS)}$ | Synchronous Driver Operation A-B at Disable | | | 4 | 6 | ns |

RECEIVER SWITCHING CHARACTERISTICS

$V_{CC} = 4.5V$ to $5.5V$, $T_A = -40$ to $85^\circ C$, unless otherwise specified. Typical values are referred to $T_a = 25^\circ C$, $V_{CC} = 5V$) (See Note 1, 3)

| Symbol | Parameter | Test Conditions | Min. | Typ. | Max. | Unit |
|------------------------|--|---------------------------|------|------|------|------|
| t_{PLH} t_{PHL} | Propagation Delay | $C_L = 15pF$ | | 18 | 30 | ns |
| t_{RPDS} | $ t_{PLH} - t_{PHL} $ Propagation Delay Skew | $C_L = 15pF$ | | 0.5 | 2 | ns |
| t_{PZL} | Output Enable Time | $C_{RL} = 15pF$ S1 Closed | | 7 | 12 | ns |
| t_{PZH} | Output Enable Time | $C_{RL} = 15pF$ S2 Closed | | 7 | 12 | ns |
| t_{PHZ} | Output Disable Time | $C_{RL} = 15pF$ S2 Closed | | 7 | 12 | ns |
| t_{PLZ} | Output Disable Time | $C_{RL} = 15pF$ S1 Closed | | 7 | 12 | ns |

Note 1: All currents into device pins are positive; all currents out of device pins are negative; all voltages are referenced to device ground unless specified.

Note 2: Applies to peak current. See typical Operating Characteristics.

Note 3: $t_r = t_f \leq 6ms$

TEST CIRCUITS AND TYPICAL CHARACTERISTICS

Figure 1 : Driver DC Test Load

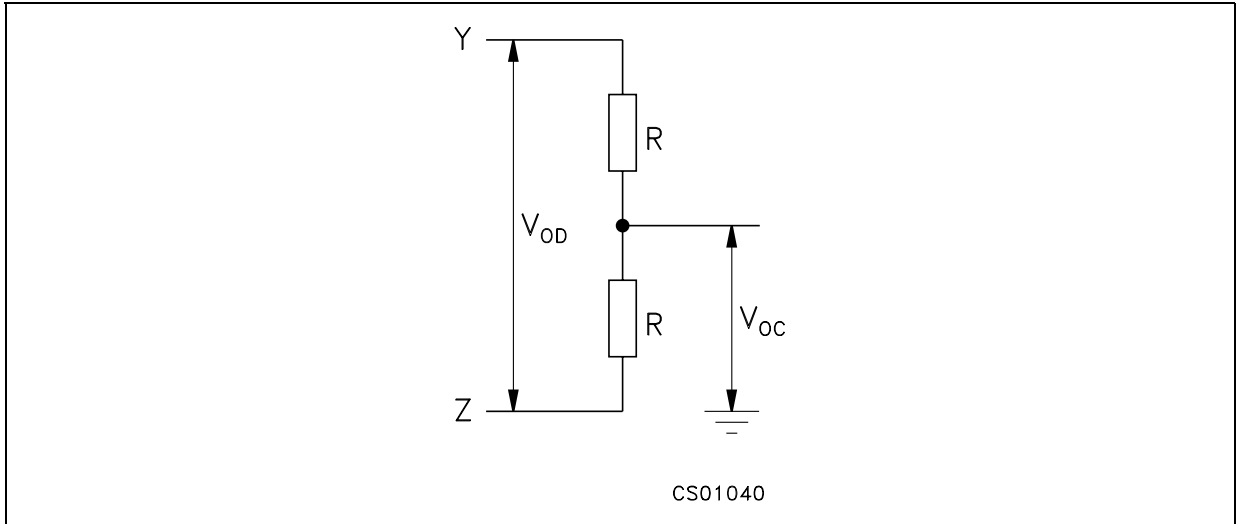

Figure 2 : Receiver Timing Test Load

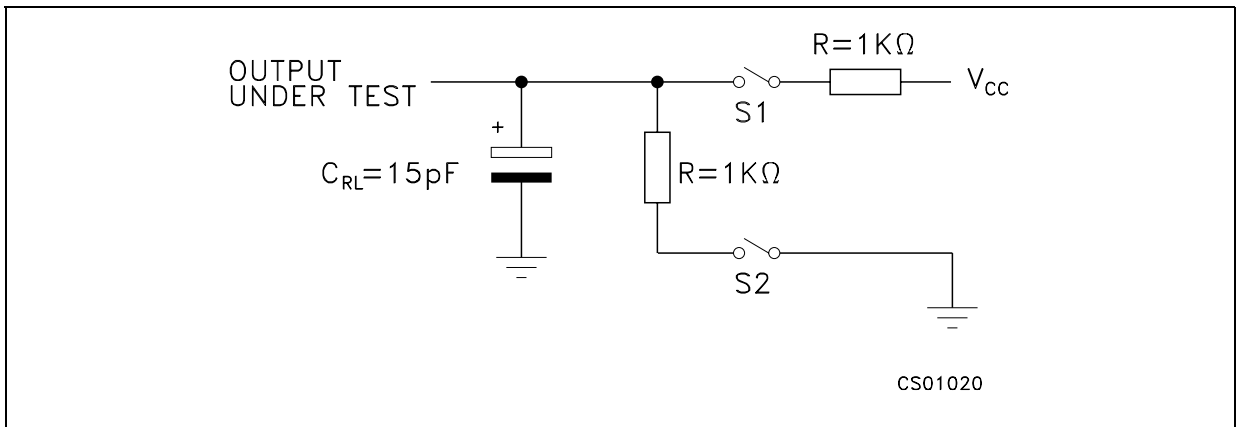

Figure 3 : Drive/Receiver Timing Test Circuit

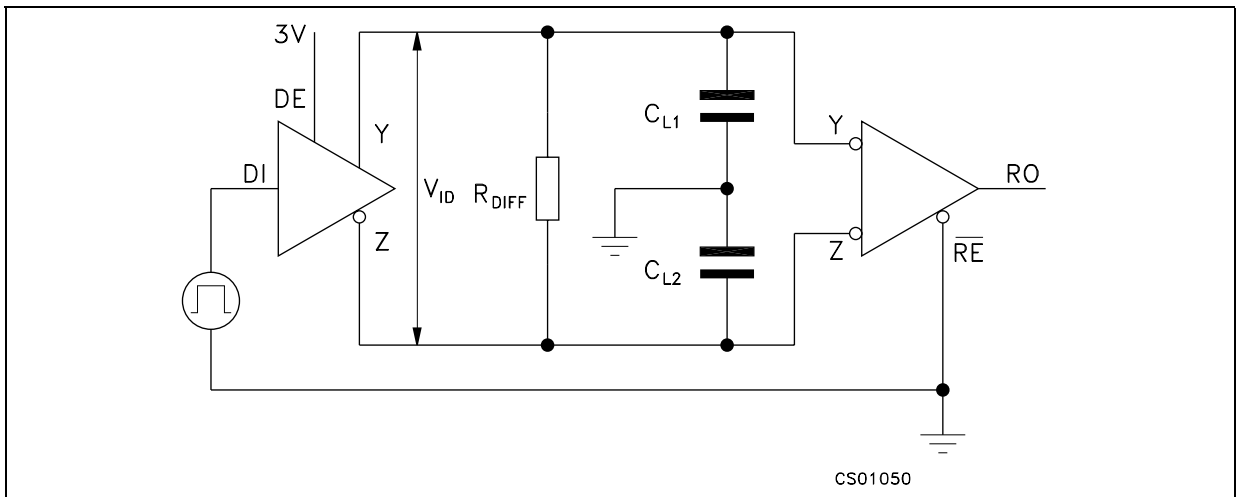

Figure 4 : Driver Timing Test Load

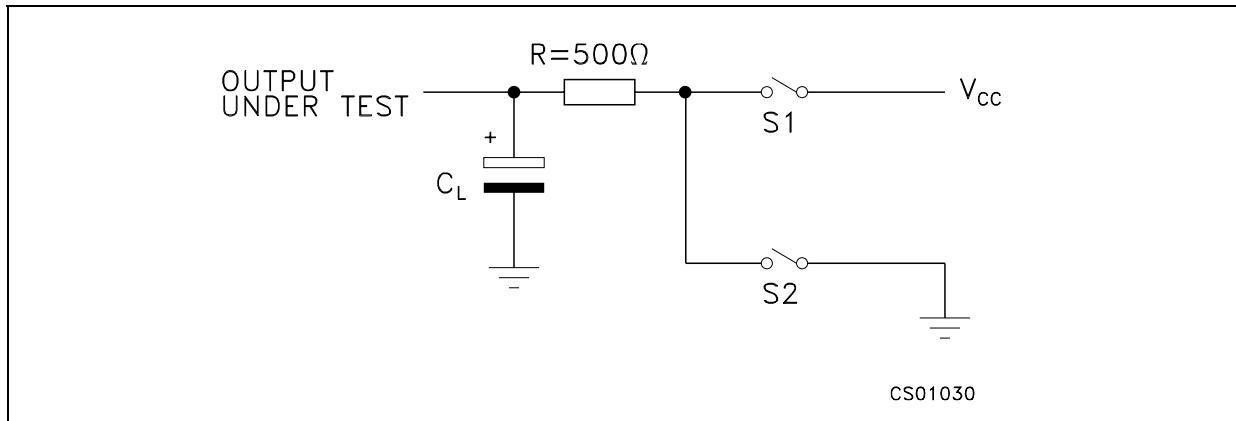

Figure 5 : Driver Propagation Delay

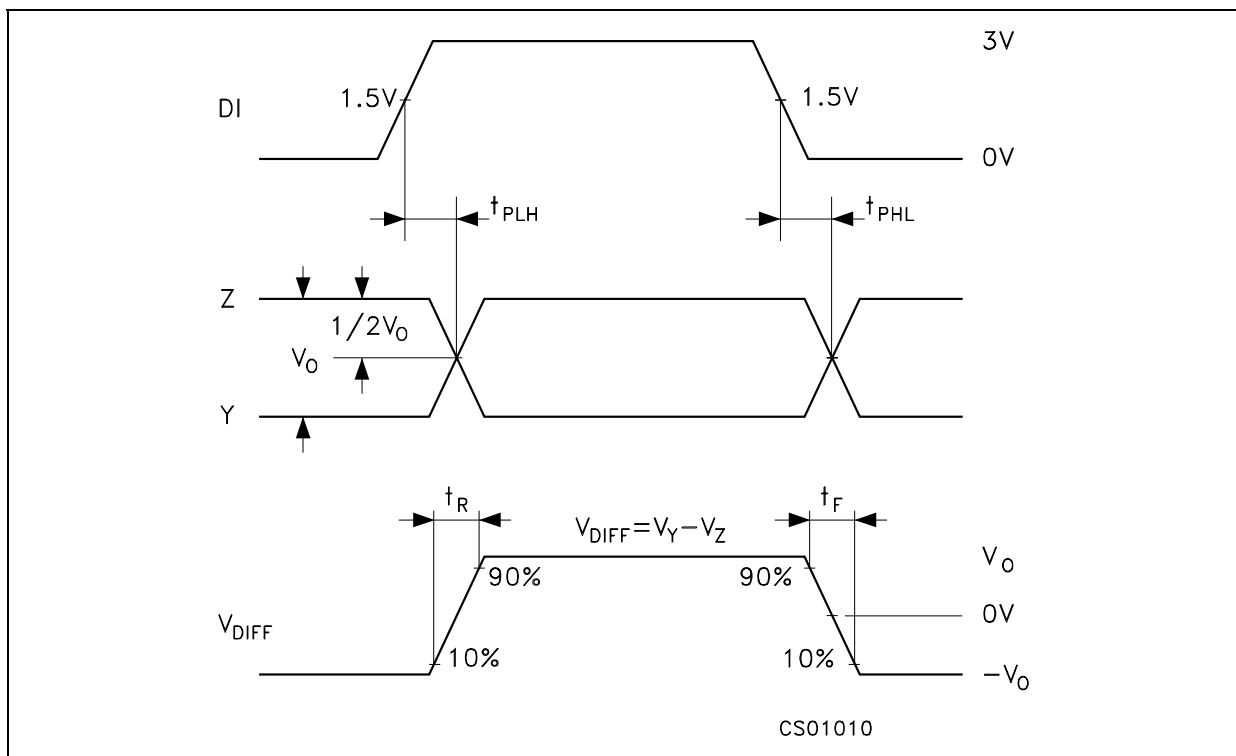

Figure 6 : Driver Enable and Disable Time

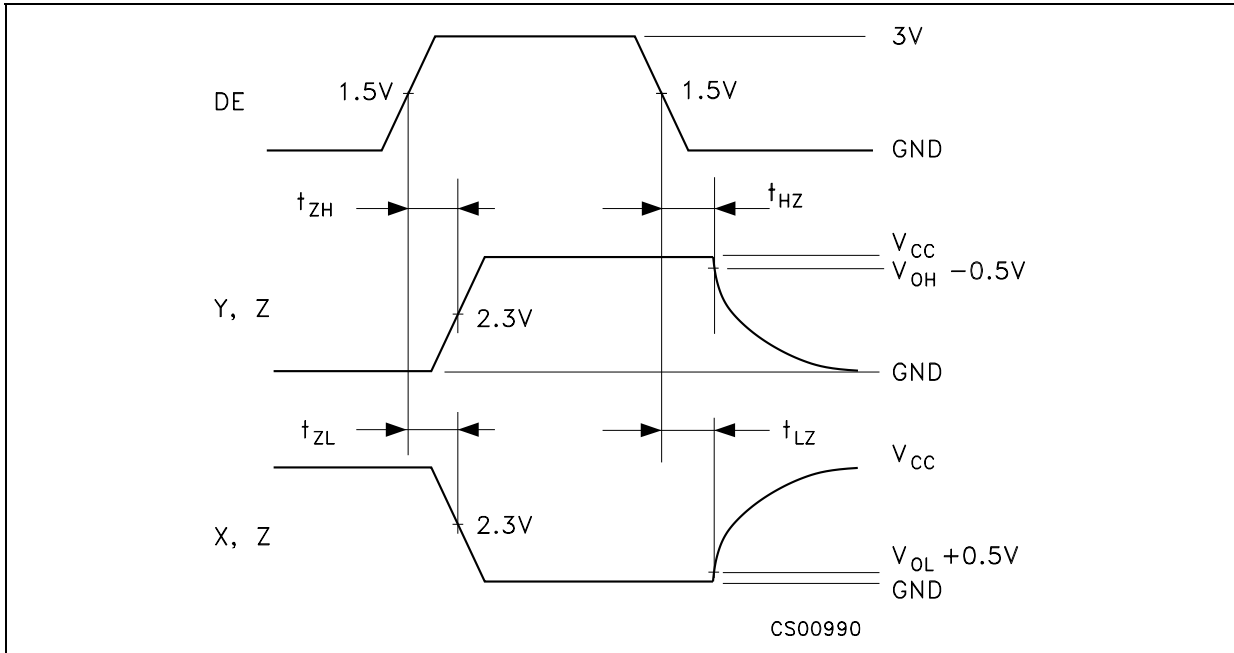

Figure 7 : Receiver Propagation Delay

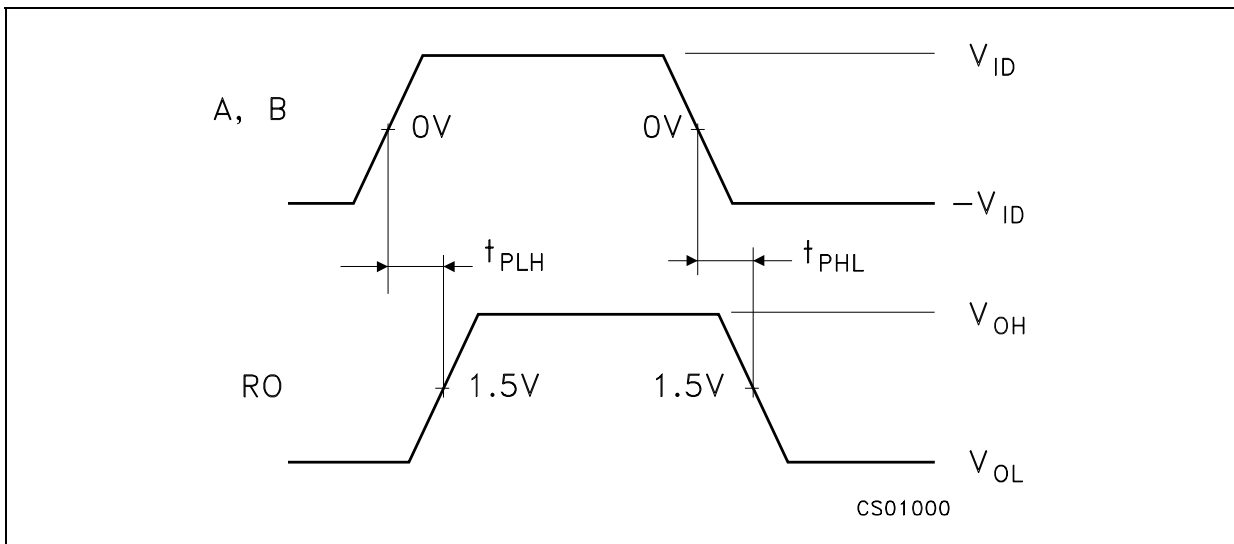

Figure 8 : Receiver Enable and Disable Time

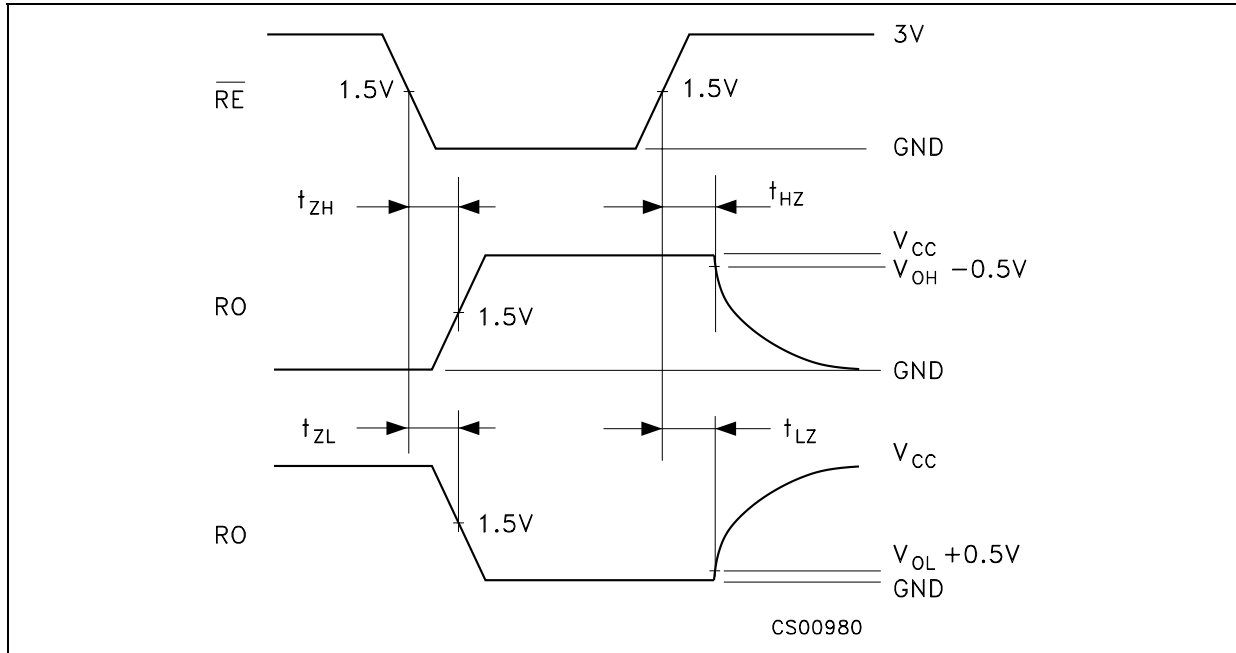

Figure 9 : Receiver Output Current vs Output Voltage (Output Low)

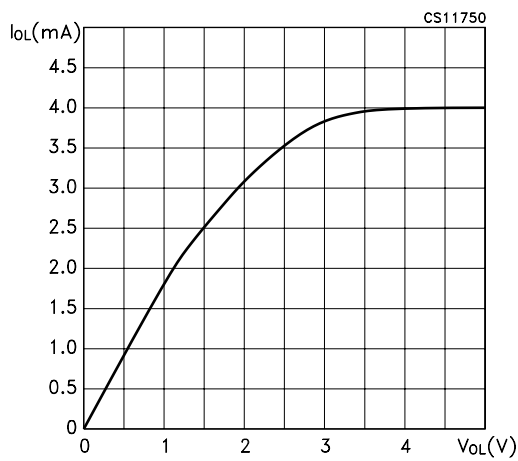

Figure 10 : Receiver Output Current vs Output Voltage (Output High)

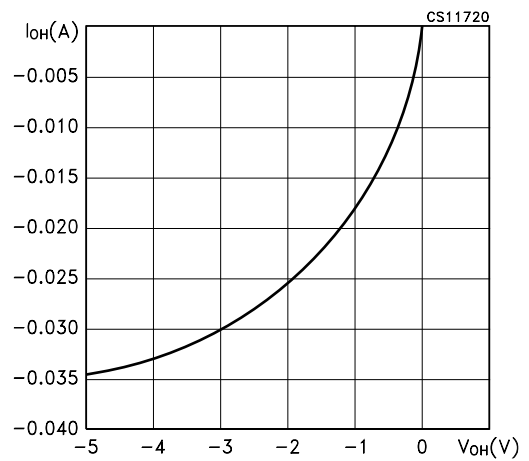

Figure 11 : Driver Diff. Output Voltage vs Common Mode Voltage (Diff. Output Low)

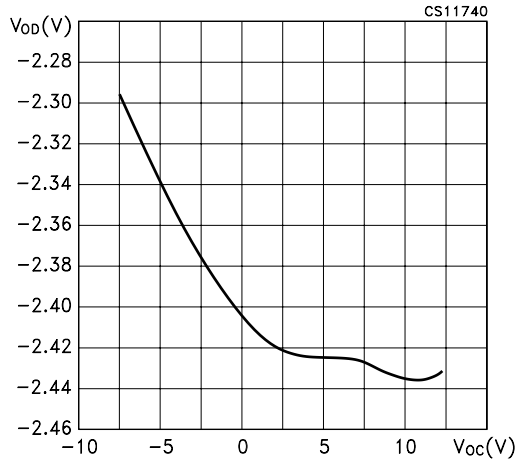

Figure 14 : Driver Short Circuit Current vs. Line Voltage (Output Low)

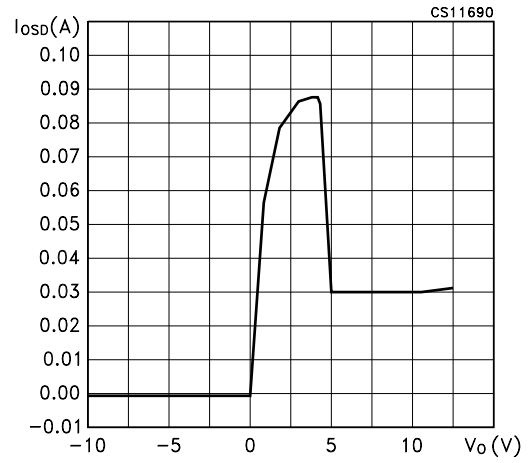

Figure 12 : Driver Diff. Output Voltage vs Common Mode Voltage (Diff. Output Low)

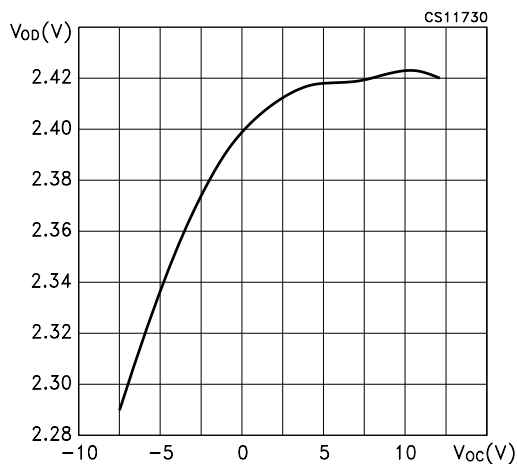

Figure 15 : Receiver Input Current vs Input Voltage

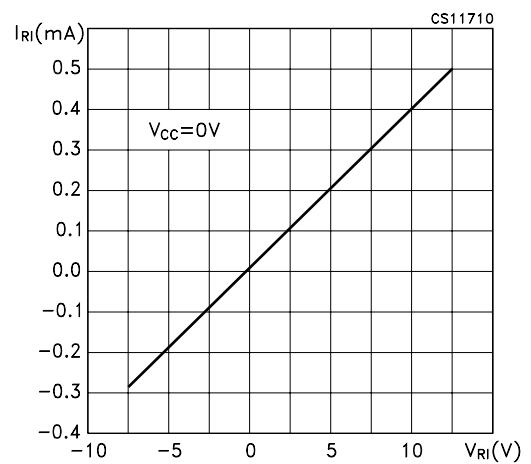
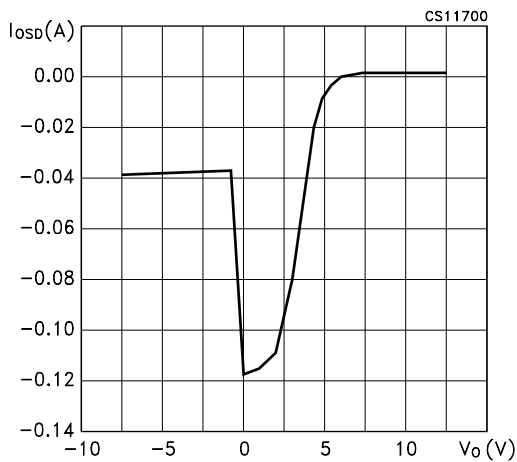
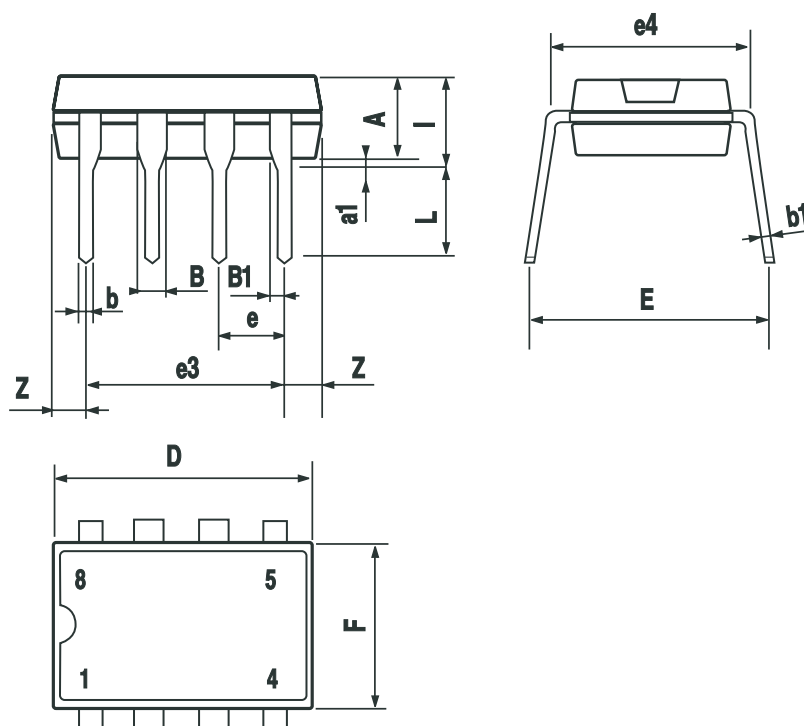

Figure 13 : Driver Short Circuit Current vs Line Voltage (Output High)



| |
|--------------------------------------|
| Plastic DIP-8 MECHANICAL DATA |
|--------------------------------------|

| DIM. | mm. | | | inch | | |
|------|------|------|------|-------|-------|-------|
| | MIN. | TYP | MAX. | MIN. | TYP. | MAX. |
| A | | 3.3 | | | 0.130 | |
| a1 | 0.7 | | | 0.028 | | |
| B | 1.39 | | 1.65 | 0.055 | | 0.065 |
| B1 | 0.91 | | 1.04 | 0.036 | | 0.041 |
| b | | 0.5 | | | 0.020 | |
| b1 | 0.38 | | 0.5 | 0.015 | | 0.020 |
| D | | | 9.8 | | | 0.386 |
| E | | 8.8 | | | 0.346 | |
| e | | 2.54 | | | 0.100 | |
| e3 | | 7.62 | | | 0.300 | |
| e4 | | 7.62 | | | 0.300 | |
| F | | | 7.1 | | | 0.280 |
| I | | | 4.8 | | | 0.189 |
| L | | 3.3 | | | 0.130 | |
| Z | 0.44 | | 1.6 | 0.017 | | 0.063 |



P001F

SO-8 MECHANICAL DATA

| DIM. | mm. | | | inch | | |
|------|------------|------|------|-------|-------|-------|
| | MIN. | TYP | MAX. | MIN. | TYP. | MAX. |
| A | | | 1.75 | | | 0.068 |
| a1 | 0.1 | | 0.25 | 0.003 | | 0.009 |
| a2 | | | 1.65 | | | 0.064 |
| a3 | 0.65 | | 0.85 | 0.025 | | 0.033 |
| b | 0.35 | | 0.48 | 0.013 | | 0.018 |
| b1 | 0.19 | | 0.25 | 0.007 | | 0.010 |
| C | 0.25 | | 0.5 | 0.010 | | 0.019 |
| c1 | 45° (typ.) | | | | | |
| D | 4.8 | | 5.0 | 0.189 | | 0.196 |
| E | 5.8 | | 6.2 | 0.228 | | 0.244 |
| e | | 1.27 | | | 0.050 | |
| e3 | | 3.81 | | | 0.150 | |
| F | 3.8 | | 4.0 | 0.149 | | 0.157 |
| L | 0.4 | | 1.27 | 0.015 | | 0.050 |
| M | | | 0.6 | | | 0.023 |
| S | 8° (max.) | | | | | |

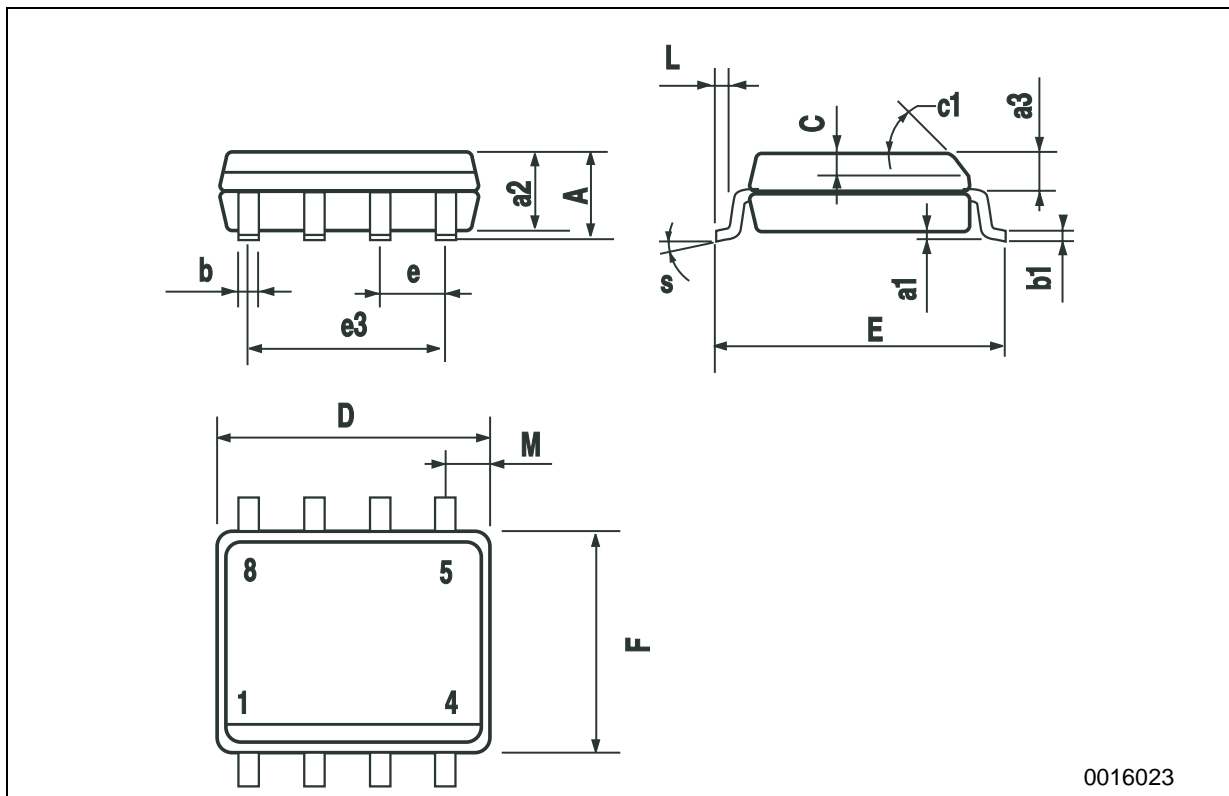

0016023

Information furnished is believed to be accurate and reliable. However, STMicroelectronics assumes no responsibility for the consequences of use of such information nor for any infringement of patents or other rights of third parties which may result from its use. No license is granted by implication or otherwise under any patent or patent rights of STMicroelectronics. Specifications mentioned in this publication are subject to change without notice. This publication supersedes and replaces all information previously supplied. STMicroelectronics products are not authorized for use as critical components in life support devices or systems without express written approval of STMicroelectronics.

© The ST logo is a registered trademark of STMicroelectronics

© 2002 STMicroelectronics - Printed in Italy - All Rights Reserved
STMicroelectronics GROUP OF COMPANIES

Australia - Brazil - Canada - China - Finland - France - Germany - Hong Kong - India - Israel - Italy - Japan - Malaysia - Malta - Morocco
Singapore - Spain - Sweden - Switzerland - United Kingdom - United States.

© <http://www.st.com>