



RBO40-40G/M/T

Application Specific Discretes
A.S.D.™

REVERSED BATTERY AND
OVERVOLTAGE PROTECTION CIRCUIT (RBO)

FEATURES

- PROTECTION AGAINST "LOAD DUMP" PULSE
- 40A DIODE TO GUARD AGAINST BATTERY REVERSAL
- MONOLITHIC STRUCTURE FOR GREATER RELIABILITY
- BREAKDOWN VOLTAGE : 24 V min.
- CLAMPING VOLTAGE : ± 40 V max.
- COMPLIANT WITH ISO / DTR 7637

DESCRIPTION

Designed to protect against battery reversal and load dump overvoltages in automotive applications, this monolithic component offers multiple functions in the same package :

D1 : reversed battery protection

T1 : clamping against negative overvoltages

T2 : Transil function against "load dump" effect.

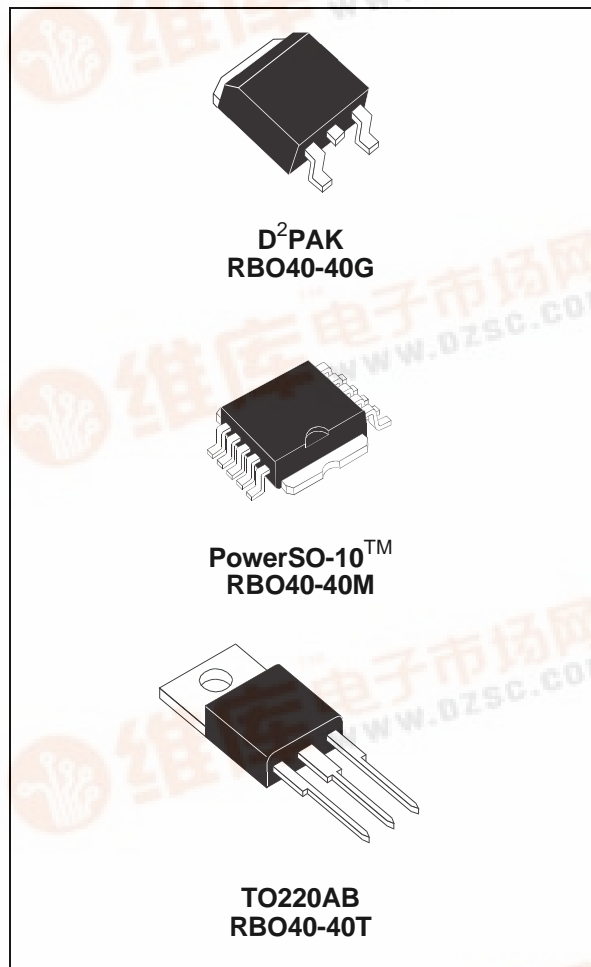

FUNCTIONAL DIAGRAM

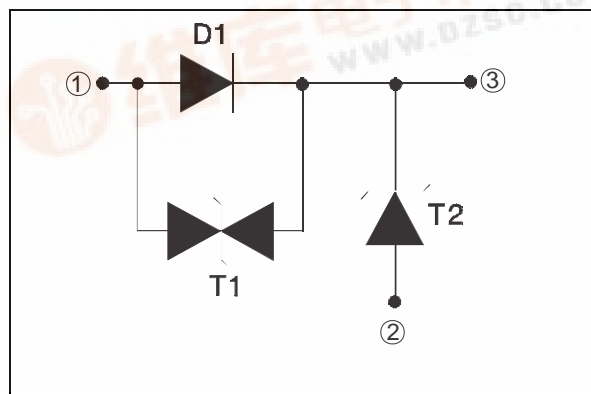

RBO40-40G / RBO40-40M / RBO40-40T

ABSOLUTE MAXIMUM RATINGS

Symbol	Parameter		Value	Unit
I_{FSM}	Non repetitive surge peak forward current (Diode D1)	$t_p = 10 \text{ ms}$	120	A
I_F	DC forward current (Diode D1)	$T_c = 75^\circ\text{C}$	40	A
V_{PP}	Peak load dump voltage (see note 1 and 2) 5 pulses (1 minute between each pulse)		80	V
P_{PP}	Peak pulse power between Input and Output (Transil T1) $T_j \text{ initial} = 25^\circ\text{C}$	10/1000 μs	1500	W
T_{stg} T_j	Storage temperature range Maximum junction temperature		- 40 to + 150 150	$^\circ\text{C}$
T_L	Maximum lead temperature for soldering during 10 s at 4.5mm from case for TO220AB		260	$^\circ\text{C}$

Note 1 : for a surge greater than the maximum value, the device will fail in short-circuit.

Note 2 : see Load Dump curves.

TM : PowerSO-10, TRANSIL and ASD are trademarks of SGS-THOMSON Microelectronics.

THERMAL RESISTANCE

Symbol	Parameter		Value	Unit
$R_{th(j-c)}$	Junction to case	RBO40-40M RBO40-40G RBO40-40T	1.0 1.0 1.0	$^\circ\text{C/W}$
$R_{th(j-a)}$	Junction to ambient	RBO40-40T	60	$^\circ\text{C/W}$

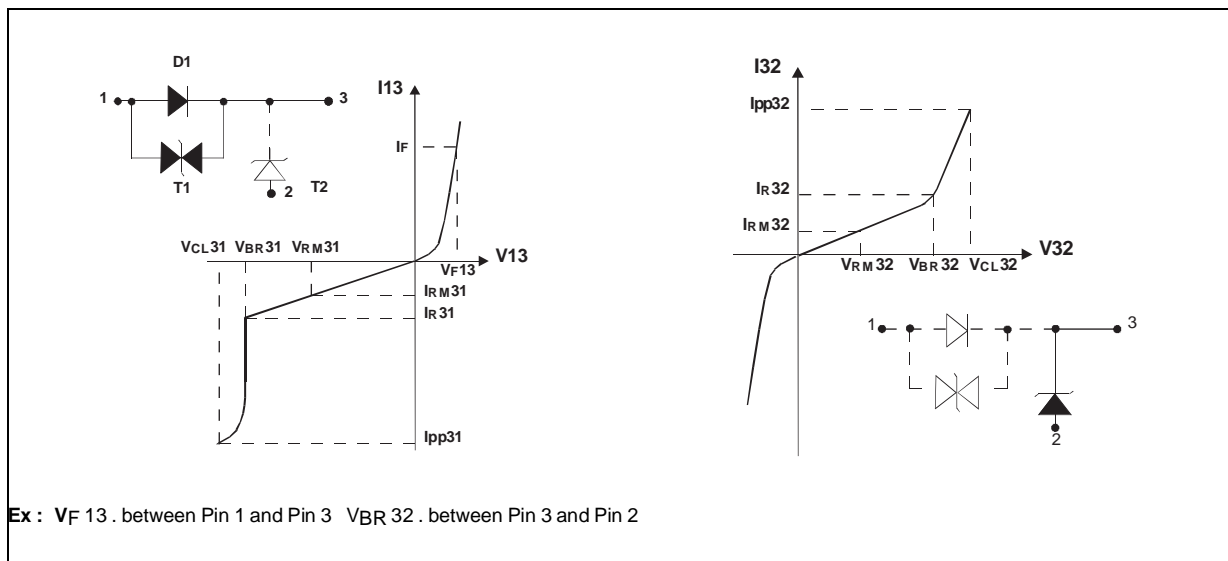

RBO40-40G / RBO40-40M / RBO40-40T

Symbol	Parameter
V_{RM31}/V_{RM32}	Stand-off voltage Transil T1 / Transil T2.
V_{BR31}/V_{BR32}	Breakdown voltage Transil T1 / Transil T2.
I_{R31}/I_{R32}	Leakage current Transil T1 / Transil T2.
V_{CL31}/V_{CL32}	Clamping voltage Transil T1 / Transil T2.
V_{F13}	Forward voltage drop Diode D1.
I_{PP}	Peak pulse current.
αT	Temperature coefficient of V_{BR} .
C_{31}/C_{32}	Capacitance Transil T1 / Transil T2.
C_{13}	Capacitance of Diode D1

ELECTRICAL CHARACTERISTICS : DIODE D1 (- 40°C < T_{amb} < + 85°C)

Symbol	Test Conditions	Value			Unit
		Min.	Typ.	Max.	
V_{F13}	$I_F = 40\text{ A}$			1.9	V
V_{F13}	$I_F = 20\text{ A}$			1.45	V
V_{F13}	$I_F = 1\text{ A}$			1	V
V_{F13}	$I_F = 100\text{ mA}$			0.95	V
C_{13}	$F = 1\text{ MHz}$ $V_R = 0\text{ V}$		3000		pF

ELECTRICAL CHARACTERISTICS : TRANSIL T1 (- 40°C < T_{amb} < + 85°C)

Symbol	Test Conditions	Value			Unit
		Min.	Typ.	Max.	
V_{BR31}	$I_R = 1\text{ mA}$	22		35	V
V_{BR31}	$I_R = 1\text{ mA}$, $T_{amb} = 25^\circ\text{C}$	24		32	V
I_{RM31}	$V_{RM} = 20\text{ V}$			100	μA
I_{RM31}	$V_{RM} = 20\text{ V}$, $T_{amb} = 25^\circ\text{C}$			10	μA
V_{CL31}	$I_{PP} = 37.5\text{ A}$, $T_j\text{ initial} = 25^\circ\text{C}$ $10/1000\mu\text{s}$			40	V
αT	Temperature coefficient of V_{BR}			9	$10^{-4}/^\circ\text{C}$
C_{31}	$F = 1\text{ MHz}$ $V_R = 0\text{ V}$		3000		pF

ELECTRICAL CHARACTERISTICS : TRANSIL T2 (- 40°C < T_{amb} < + 85°C)

Symbol	Test Conditions	Value	Typ.	Max.	Unit
		Min.			
V_{BR32}	$I_R = 1\text{ mA}$	22		35	V
V_{BR32}	$I_R = 1\text{ mA}$, $T_{amb} = 25^\circ\text{C}$	24		32	V
I_{RM32}	$V_{RM} = 20\text{ V}$			100	μA
I_{RM32}	$V_{RM} = 20\text{ V}$, $T_{amb} = 25^\circ\text{C}$			10	μA
V_{CL32}	$I_{PP} = 20\text{ A}$ (note 1)			40	V
αT	Temperature coefficient of V_{BR}			9	$10^{-4}/^\circ\text{C}$
C_{32}	$F = 1\text{ MHz}$ $V_R = 0\text{ V}$		8000		pF

Note 1 : One pulse, see pulse definition in load dump test generator circuit.

RBO40-40G / RBO40-40M / RBO40-40T

PRODUCT DESCRIPTION

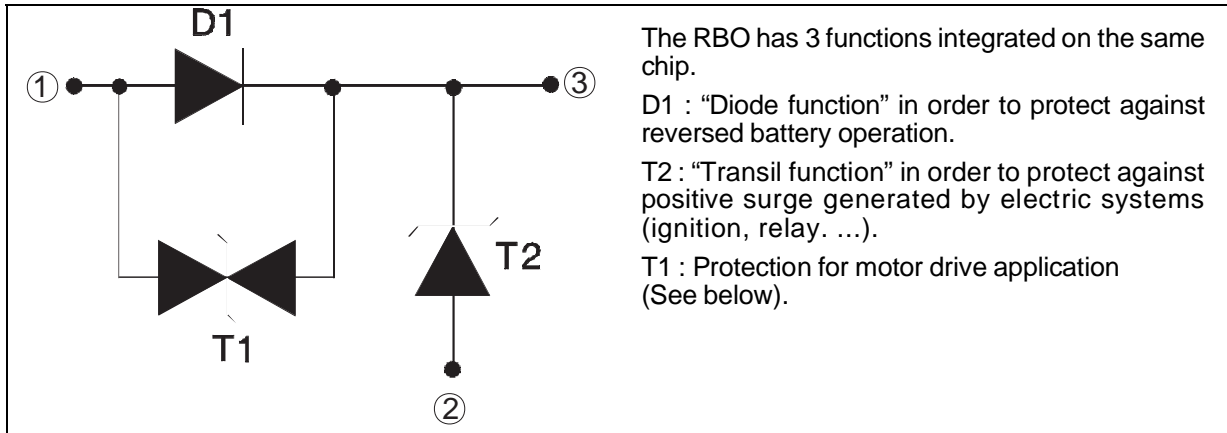

BASIC APPLICATION

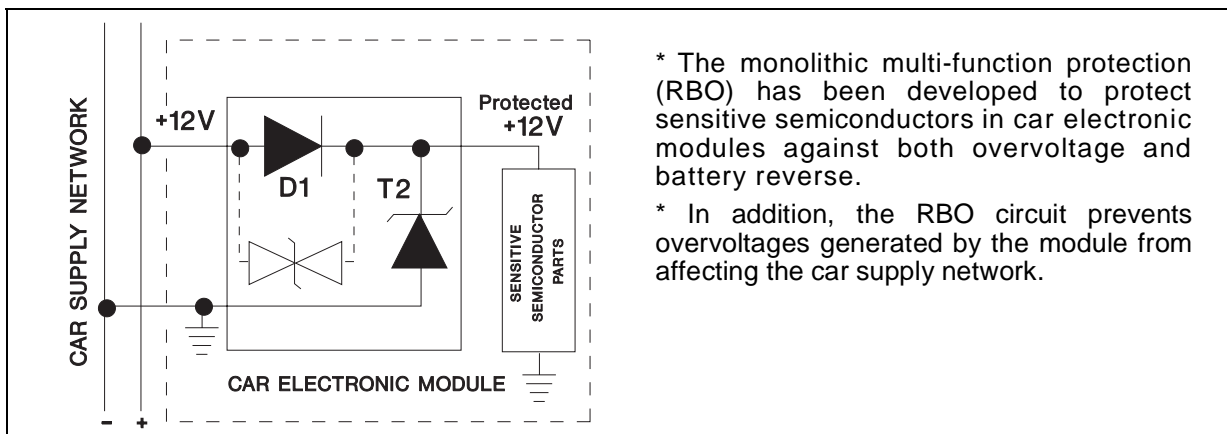

MOTOR DRIVER APPLICATION

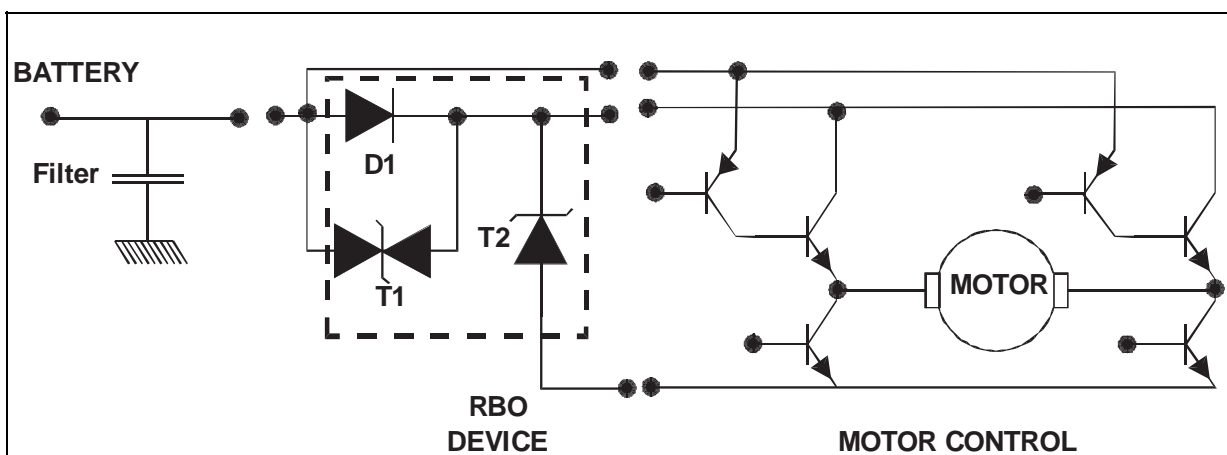

In this application, one half of the motor drive circuit is supplied through the "RBO" and is thus protected as per its basic function application.

The second part is connected directly to the "car supply network" and is protected as follows :

- For positive surges : T2 (clamping phase) and D1 in forward-biased.
- For negative surges : T1 (clamping phase) and T2 in forward-biased.

RBO40-40G / RBO40-40M / RBO40-40T

PINOUT configuration in D²PAK :

- Input (1) : Pin 1
- Output (3) : Pin 3
- Gnd (2) : Connected to base Tab

Marking : Logo, date code, RBO40-40G

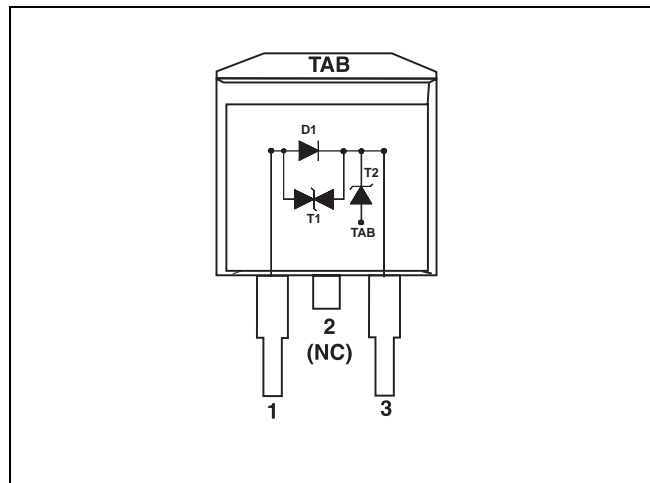

PINOUT configuration in PowerSO-10 :

- Input (1) : Pin 1 to 5
- Output (3) : Pin 6 to 10
- Gnd (2) : Connected to base Tab

Marking : Logo, date code, RBO40-40M

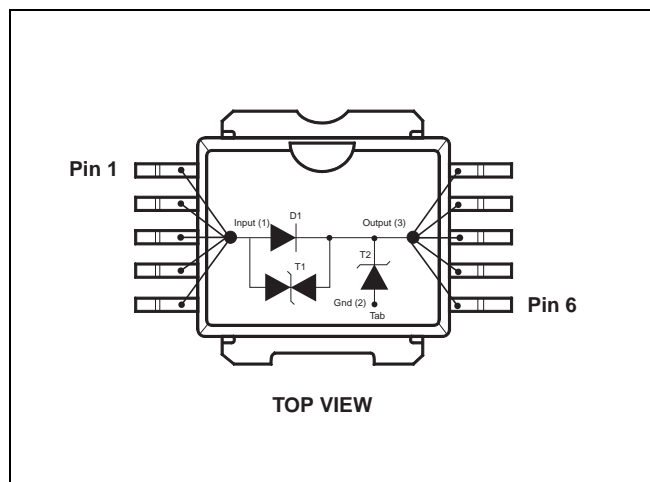

PINOUT configuration in TO220AB :

- Input (1) : Pin 1
- Output (3) : Pin 3
- GND (2) : Connected to base Tab

Marking : Logo, date code, RBO40-40T

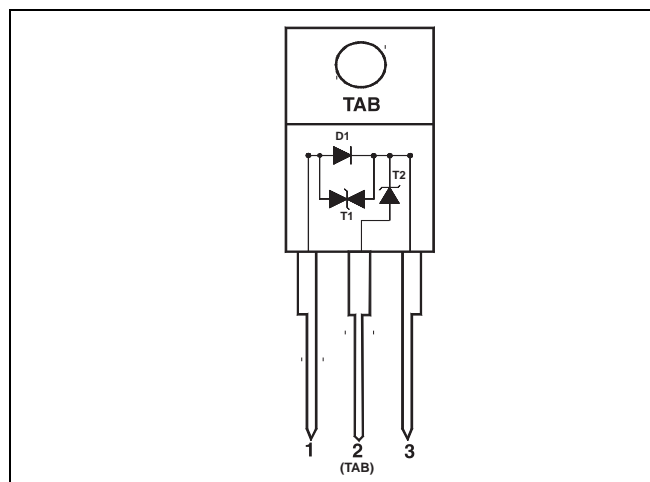

RBO40-40G / RBO40-40M / RBO40-40T

LOAD DUMP TEST GENERATOR CIRCUIT (SCHAFFNER NSG 506 C). Issued from ISO / DTR 7637.

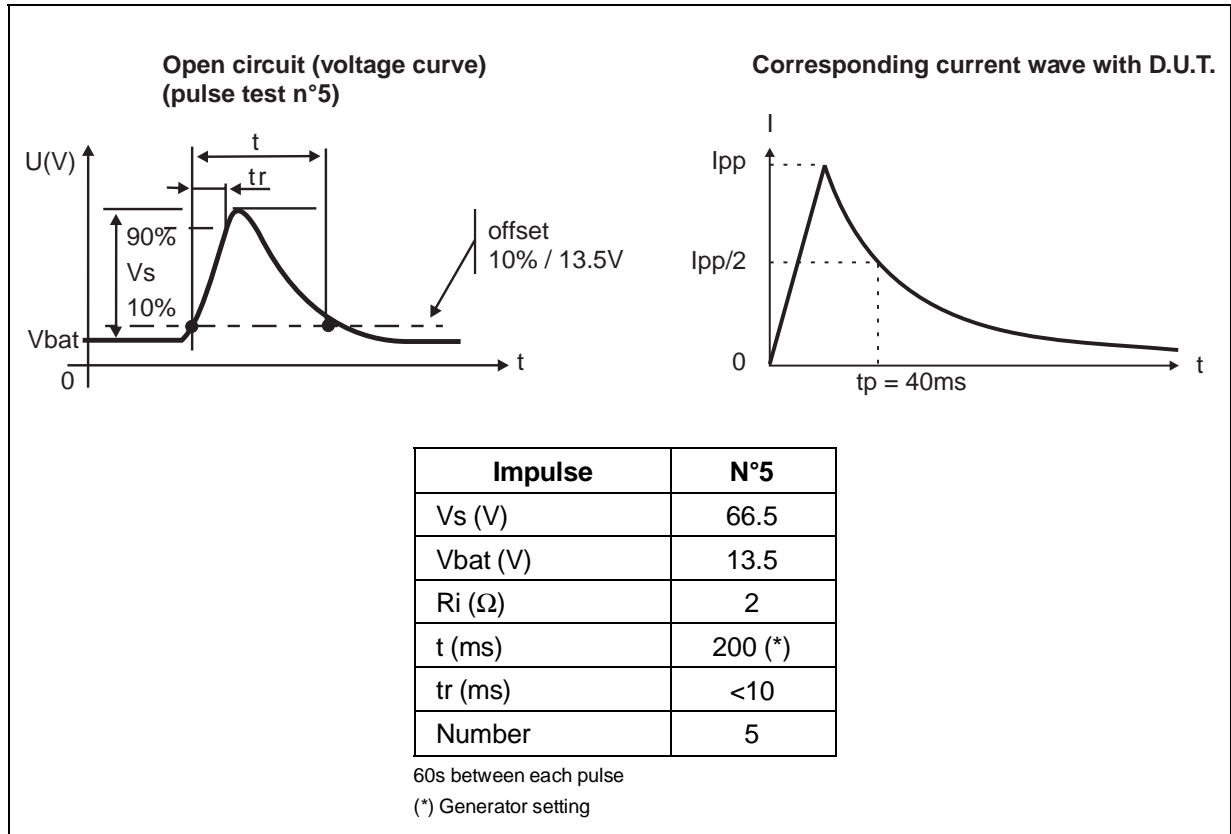

CALIBRATION METHOD FOR SCHAFFNER NSG 506 C

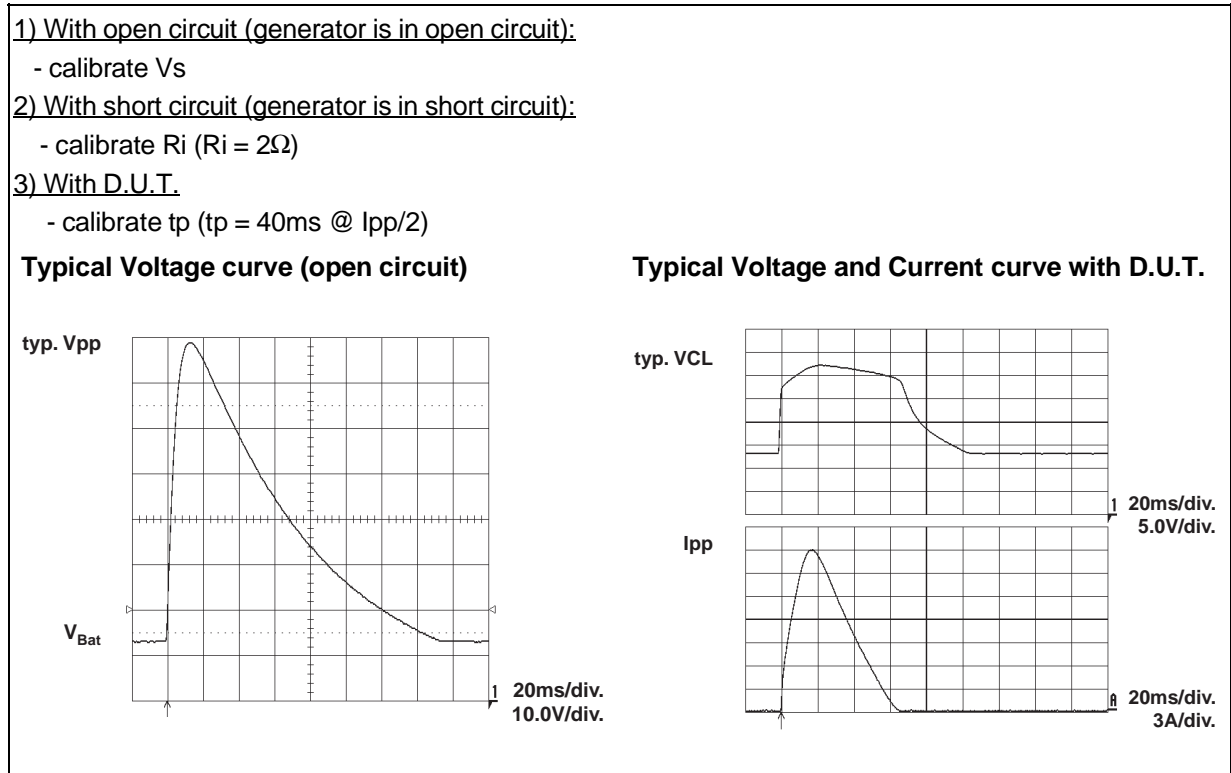

Fig. 1 : Peak pulse power versus exponential pulse duration (T_j initial = 85°C).

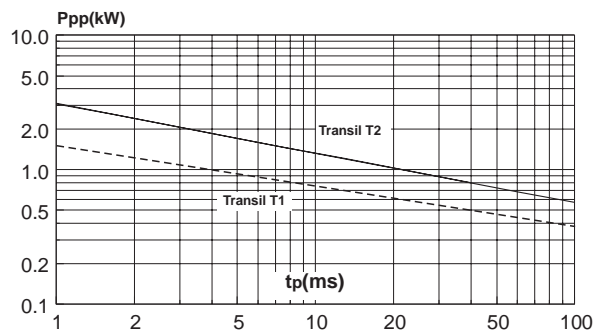

Fig. 2-1 : Clamping voltage versus peak pulse current (T_j initial = 85°C).

Exponential waveform $t_p = 40$ ms and $t_p = 1$ ms (TRANSIL T2).

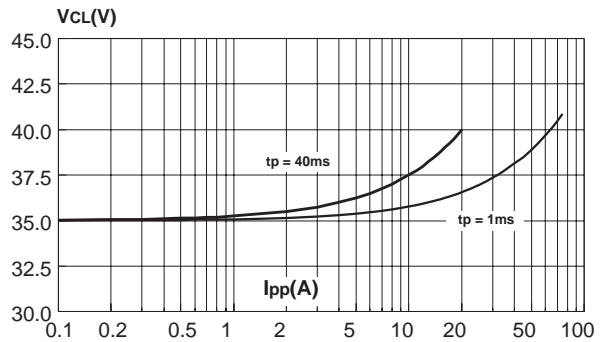

Fig. 2-2 : Clamping voltage versus peak pulse current (T_j initial = 85°C).

Exponential waveform $t_p = 1$ ms and $t_p = 20 \mu s$ (TRANSIL T1).

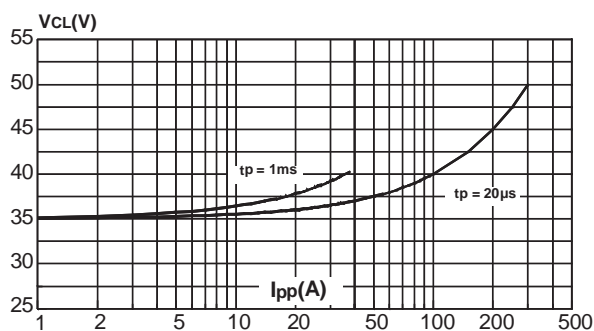
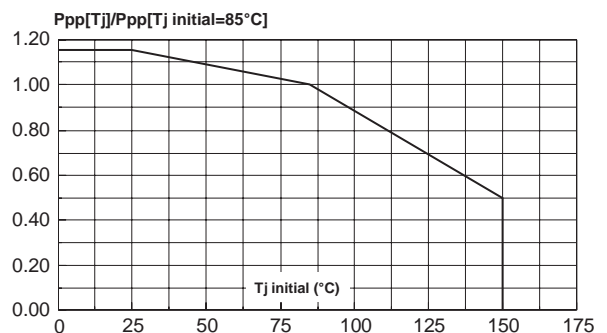

Fig. 3 : Relative variation of peak pulse power versus junction temperature.



RBO40-40G / RBO40-40M / RBO40-40T

Fig. 4 : Relative variation of thermal impedance junction to case versus pulse duration.

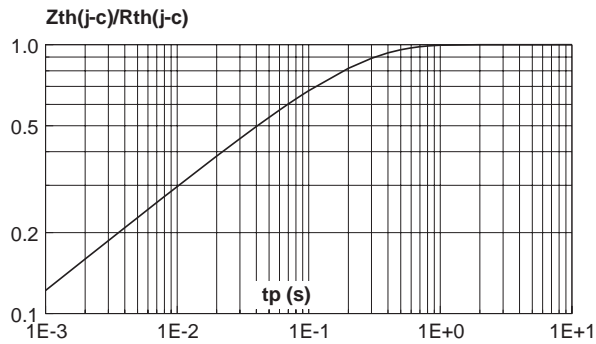

Fig. 5-1 : Peak forward voltage drop versus peak forward current (typical values) - (TRANSIL T2).

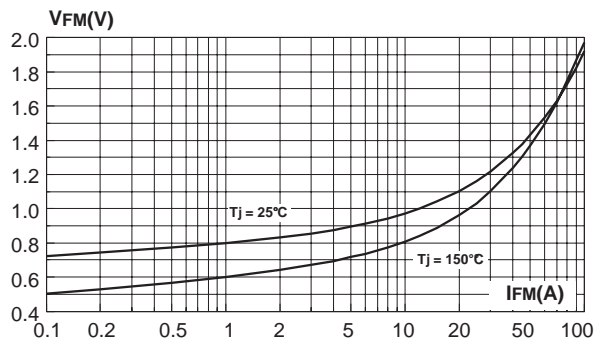

Fig. 5-2 : Peak forward voltage drop versus peak forward current (typical values) - (DIODE D1).

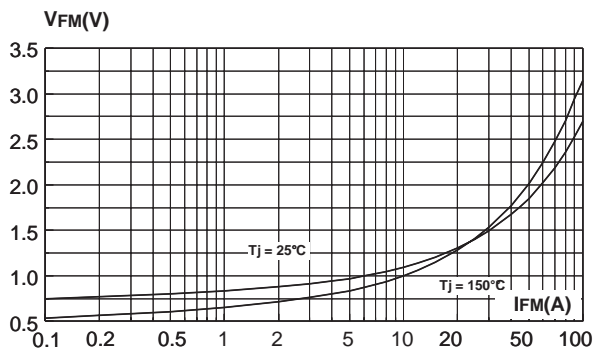
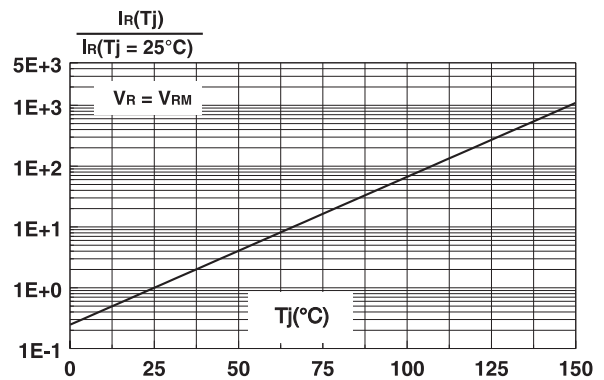
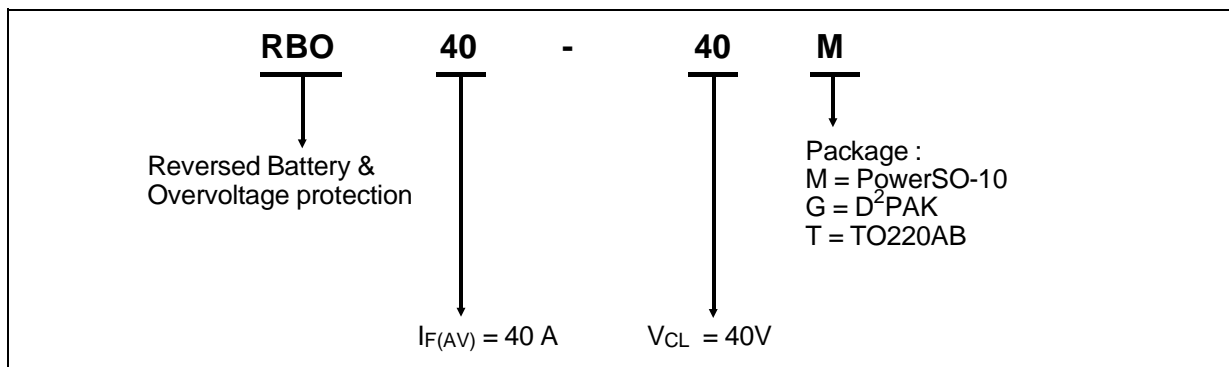

Fig. 6 : Relative variation of leakage current versus junction temperature.



ORDERING INFORMATION



PACKAGE MECHANICAL DATA

D²PAK Plastic

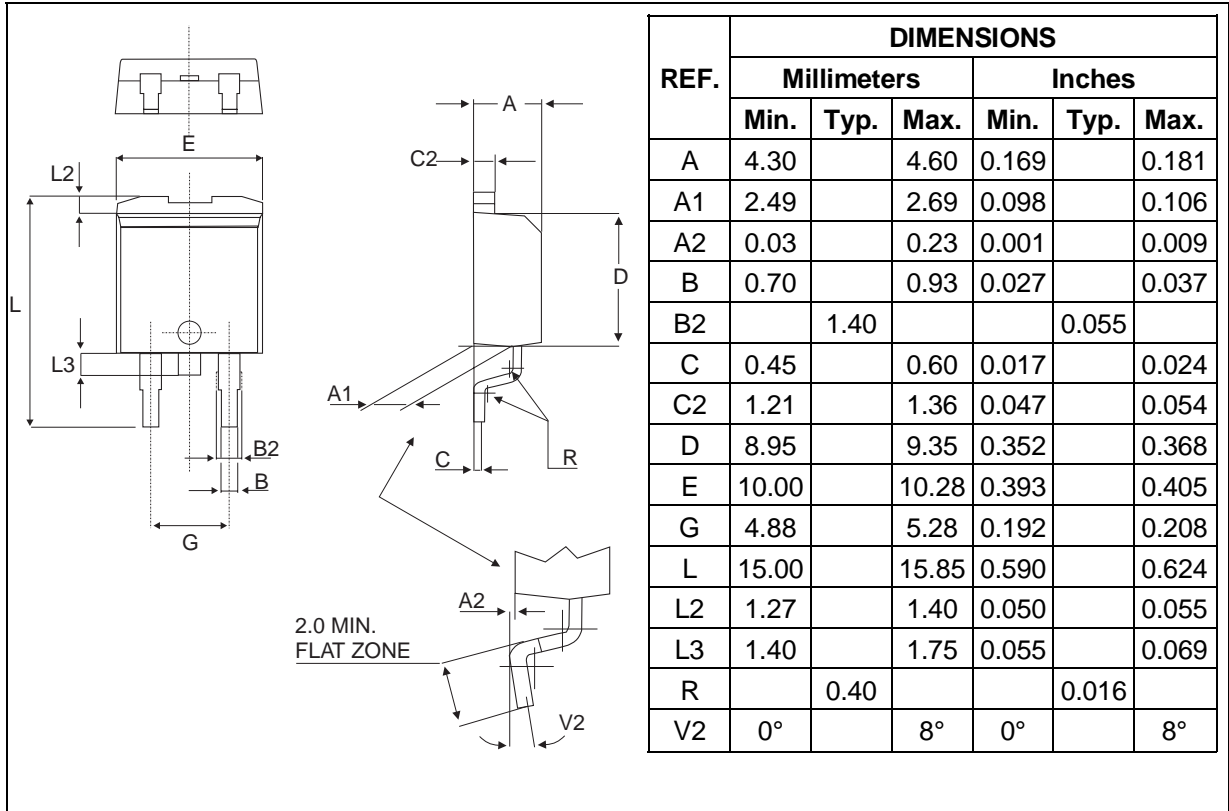

FOOT-PRINT D²PAK

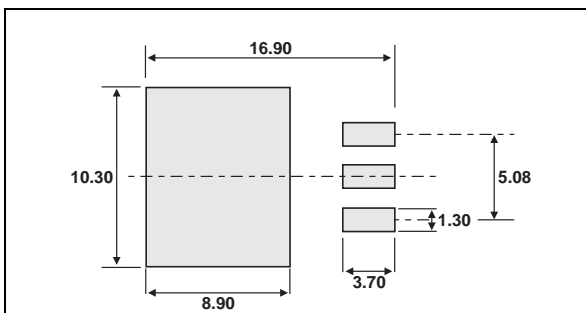

SOLDERING RECOMMENDATION

The soldering process causes considerable thermal stress to a semiconductor component. This has to be minimized to assure a reliable and extended lifetime of the device. The PowerSO-10 package can be exposed to a maximum temperature of 260°C for 10 seconds. However a proper soldering of the package could be done at 215°C for 3 seconds. Any solder temperature profile should be within these limits. As reflow techniques are most common in surface mounting, typical heating profiles are given in Figure 1, either for mounting on FR4 or on metal-backed boards. For each particular board, the appropriate heat profile has to be adjusted experimentally. The present proposal is just a starting point. In any case, the following precautions have to be considered :

- always preheat the device
- peak temperature should be at least 30 °C higher than the melting point of the solder alloy chosen

- thermal capacity of the base substrate
Voids pose a difficult reliability problem for large surface mount devices. Such voids under the package result in poor thermal contact and the high thermal resistance leads to component failures. The PowerSO-10 is designed from scratch to be solely a surface mount package, hence symmetry in the x- and y-axis gives the package excellent weight balance. Moreover, the PowerSO-10 offers the unique possibility to control easily the flatness and quality of the soldering process. Both the top and the bottom soldered edges of the package are accessible for visual inspection (soldering meniscus). Coplanarity between the substrate and the package can be easily verified. The quality of the solder joints is very important for two reasons : (I) poor quality solder joints result directly in poor reliability and (II) solder thickness affects the thermal resistance significantly. Thus a tight control of this parameter results in thermally efficient and reliable solder joints.

Fig. 1 : Typical reflow soldering heat profile

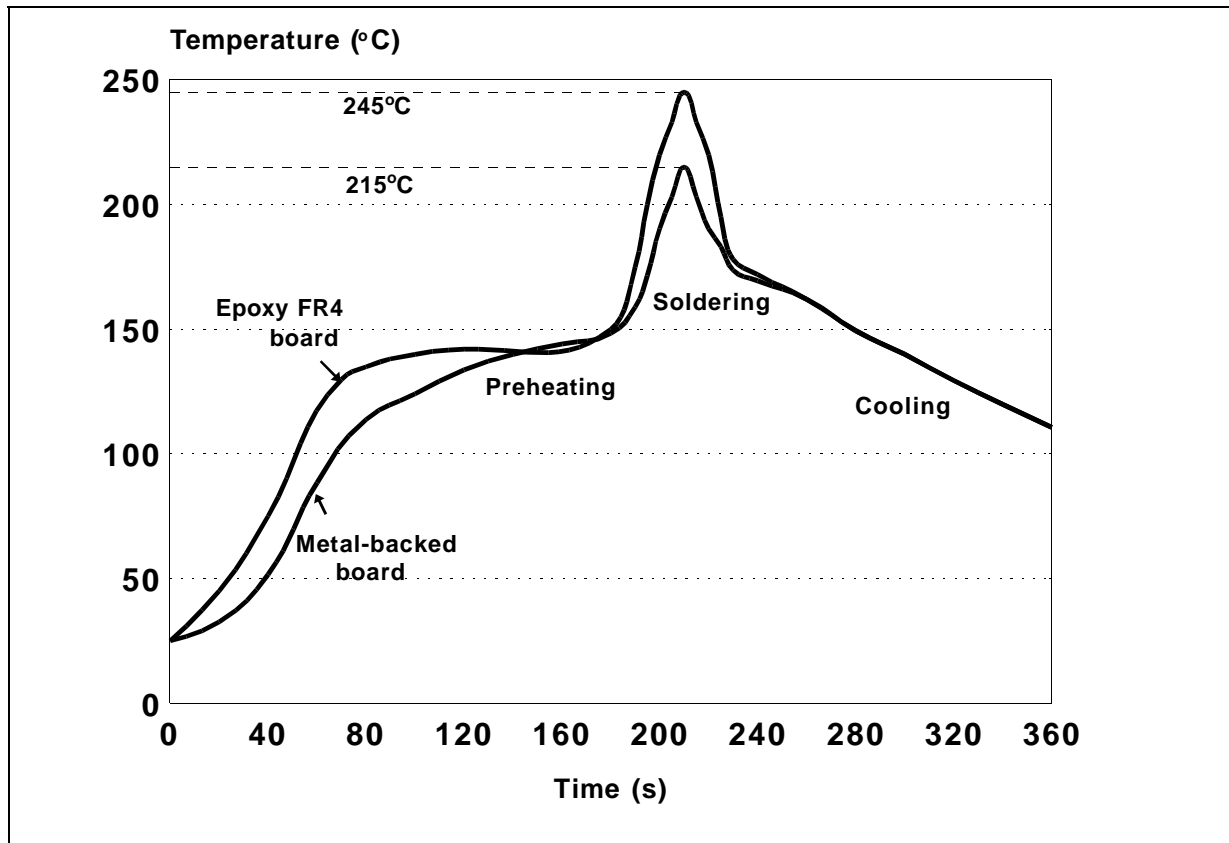

SUBSTRATES AND MOUNTING INFORMATION

The use of epoxy FR4 boards is quite common for surface mounting techniques, however, their poor thermal conduction compromises the otherwise outstanding thermal performance of the PowerSO-10. Some methods to overcome this limitation are discussed below.

One possibility to improve the thermal conduction is the use of large heat spreader areas at the copper layer of the PC board. This leads to a reduction of thermal resistance to 35 °C for 6 cm² of the board heatsink (see fig. 2).

Use of copper-filled through holes on conventional FR4 techniques will increase the metallization and

decrease thermal resistance accordingly. Using a configuration with 16 holes under the spreader of the package with a pitch of 1.8 mm and a diameter of 0.7 mm, the thermal resistance (junction - heatsink) can be reduced to 12°C/W (see fig. 3). Beside the thermal advantage, this solution allows multi-layer boards to be used. However, a drawback of this traditional material prevents its use in very high power, high current circuits. For instance, it is not advisable to surface mount devices with currents greater than 10 A on FR4 boards. A Power Mosfet or Schottky diode in a surface mount power package can handle up to around 50 A if better substrates are used.

Fig. 2 : Mounting on epoxy FR4 head dissipation by extending the area of the copper layer

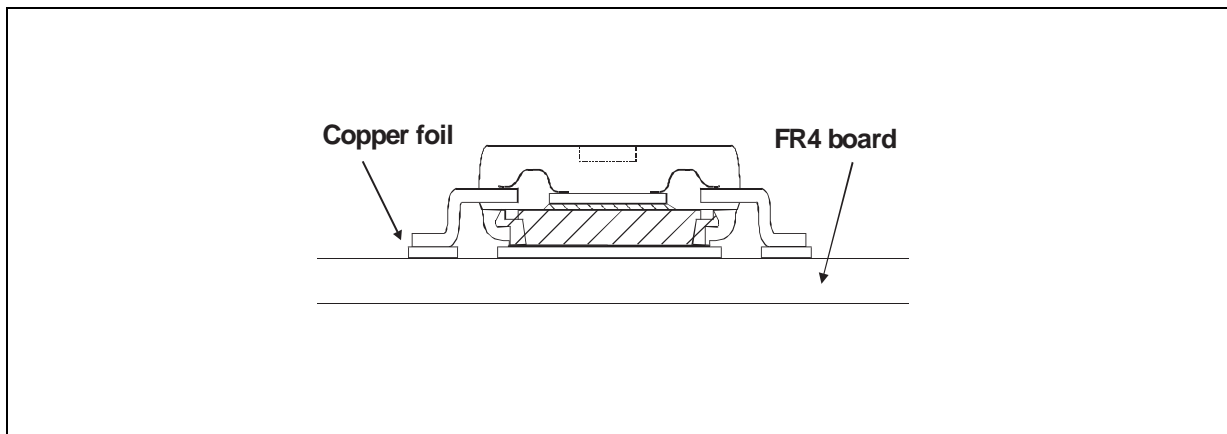
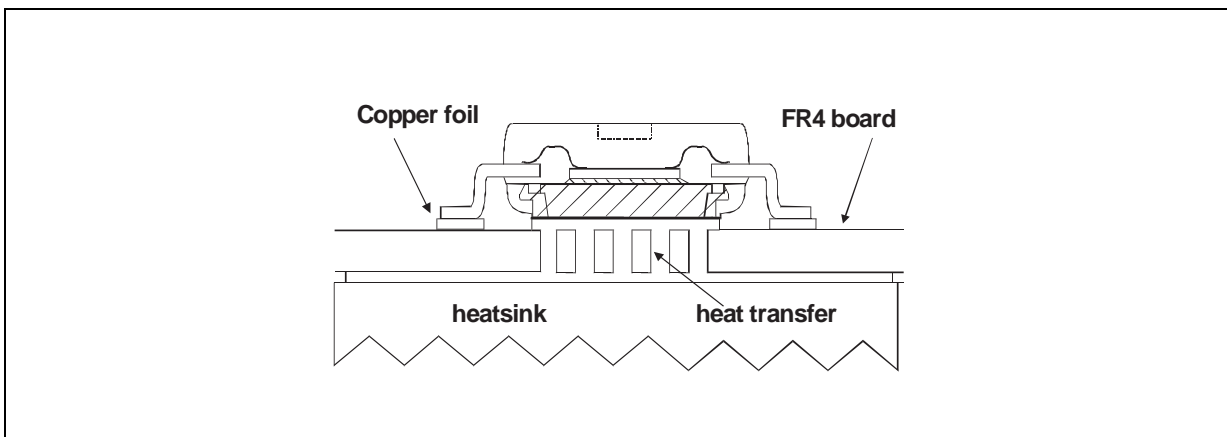

Fig. 3 : Mounting on epoxy FR4 by using copper-filled through holes for heat transfer



RBO40-40G / RBO40-40M / RBO40-40T

A new technology available today is IMS - an Insulated Metallic Substrate. This offers greatly enhanced thermal characteristics for surface mount components. IMS is a substrate consisting of three different layers, (I) the base material which is available as an aluminium or a copper plate, (II) a thermal conductive dielectrical layer and (III) a copper foil, which can be etched as a circuit layer. Using this material a thermal resistance of $8^{\circ}\text{C}/\text{W}$ with 40 cm^2 of board floating in air is achievable (see fig. 4). If even higher power is to be dissipated an external heatsink could be applied which leads to an $R_{\text{th(j-a)}}$ of $3.5^{\circ}\text{C}/\text{W}$ (see Fig. 5), assuming that R_{th} (heatsink-air) is equal to R_{th} (junction-heatsink). This is commonly applied in practice, leading to reasonable heatsink dimensions. Often power devices are defined by

considering the maximum junction temperature of the device. In practice, however, this is far from being exploited. A summary of various power management capabilities is made in table 1 based on a reasonable ΔT of 70°C junction to air.

The PowerSO-10 concept also represents an attractive alternative to C.O.B. techniques. PowerSO-10 offers devices fully tested at low and high temperature. Mounting is simple - only conventional SMT is required - enabling the users to get rid of bond wire problems and the problem to control the high temperature soft soldering as well. An optimized thermal management is guaranteed through PowerSO-10 as the power chips must in any case be mounted on heat spreaders before being mounted onto the substrate.

Fig. 4 : Mounting on metal backed board

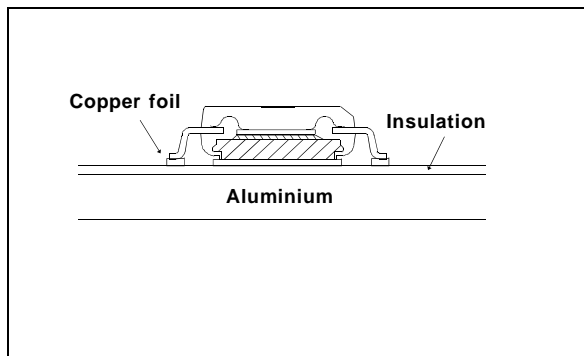

Fig. 5 : Mounting on metal backed board with an external heatsink applied

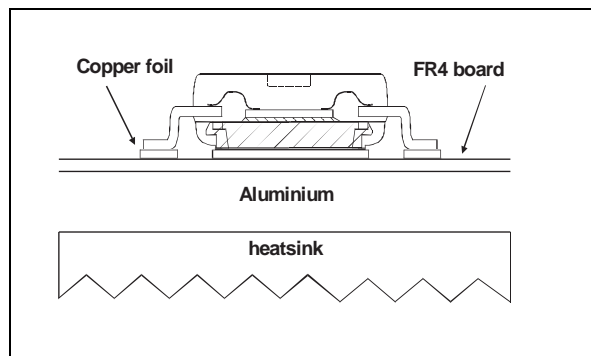
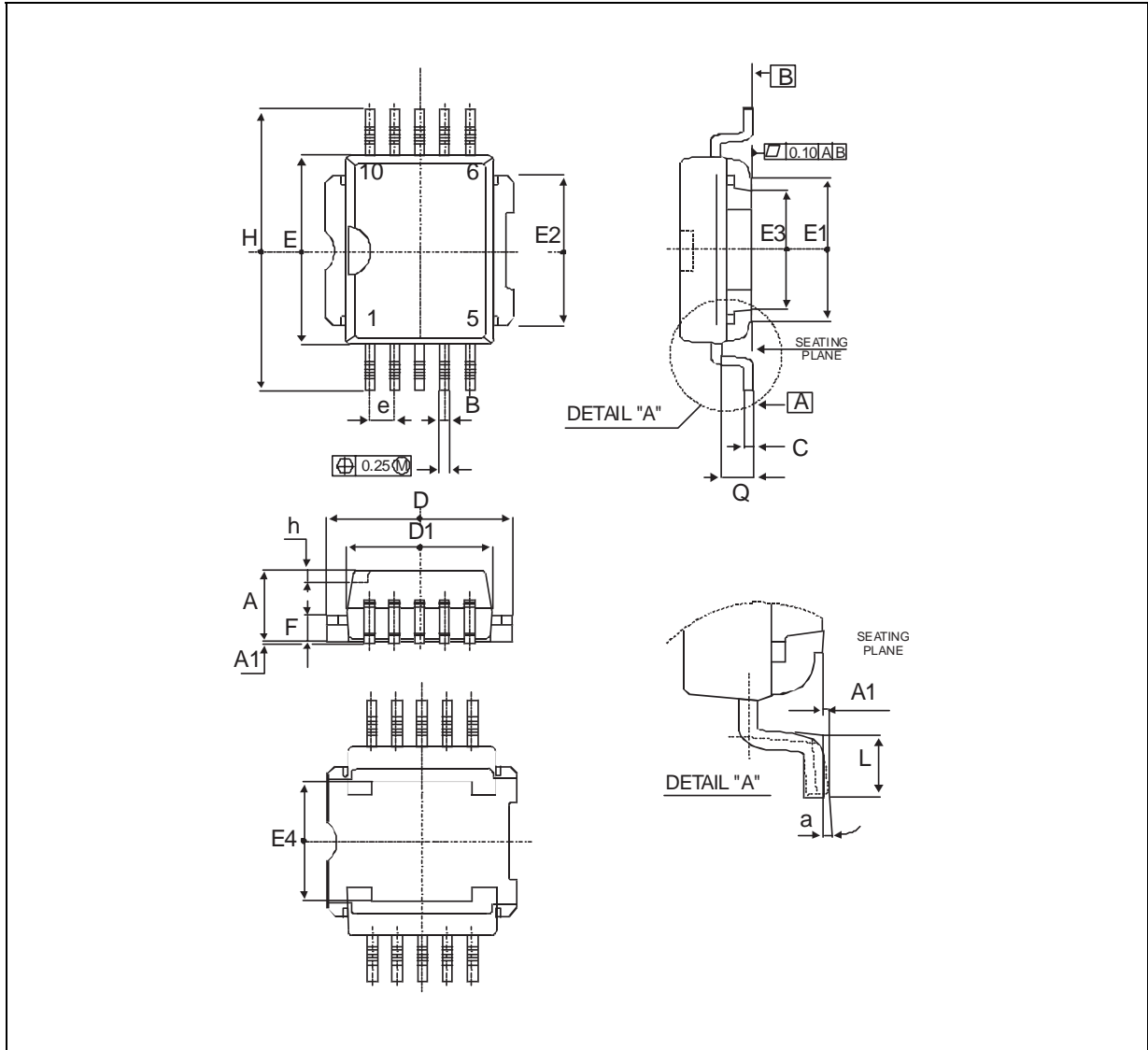

TABLE 1

PowerSo-10 package mounted on	$R_{\text{th (j-a)}}$	P Diss
1.FR4 using the recommended pad-layout	$50^{\circ}\text{C}/\text{W}$	1.5 W
2.FR4 with heatsink on board (6cm^2)	$35^{\circ}\text{C}/\text{W}$	2.0 W
3.FR4 with copper-filled through holes and external heatsink applied	$12^{\circ}\text{C}/\text{W}$	5.8 W
4. IMS floating in air (40 cm^2)	$8^{\circ}\text{C}/\text{W}$	8.8 W
5. IMS with external heatsink applied	$3.5^{\circ}\text{C}/\text{W}$	20 W

PACKAGE MECHANICAL DATA



REF.	DIMENSIONS					
	Millimeters			Inches		
	Min.	Typ.	Max.	Min.	Typ.	Max.
A	3.35		3.65	0.131		0.143
A1	0.00		0.10	0.00		0.0039
B	0.40		0.60	0.0157		0.0236
C	0.35		0.55	0.0137		0.0217
D	9.40		9.60	0.370		0.378
D1	7.40		7.60	0.291		0.299
E	9.30		9.50	0.366		0.374
E1	7.20		7.40	0.283		0.291
E2	7.20		7.60	0.283		0.299

REF.	DIMENSIONS					
	Millimeters			Inches		
	Min.	Typ.	Max.	Min.	Typ.	Max.
E3	6.10		6.35	0.240		0.250
E4	5.90		6.10	0.232		0.240
e		1.27			0.05	
F	1.25		1.35	0.0492		0.0531
H	13.80		14.40	0.543		0.567
h		0.50			0.019	
L	1.20		1.80	0.0472		0.0708
Q		1.70			0.067	
a	0°		8°	0°		8°

RBO40-40G / RBO40-40M / RBO40-40T

**FOOT PRINT
MOUNTING PAD LAYOUT
RECOMMENDED**

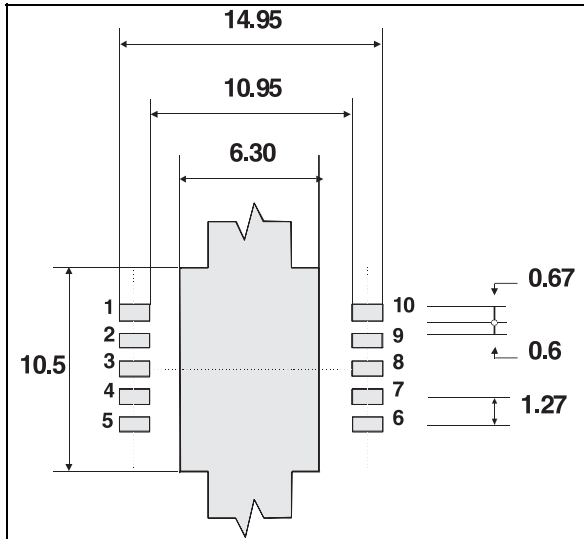

Dimensions in millimeters

HEADER SHAPE

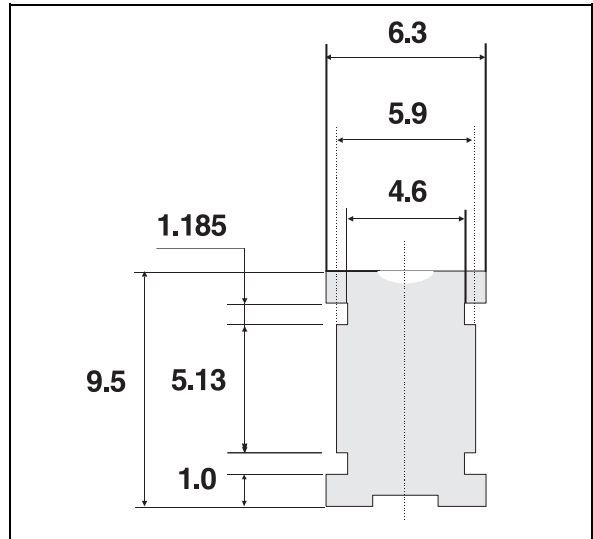

Dimensions in millimeters

SHIPPING TUBE

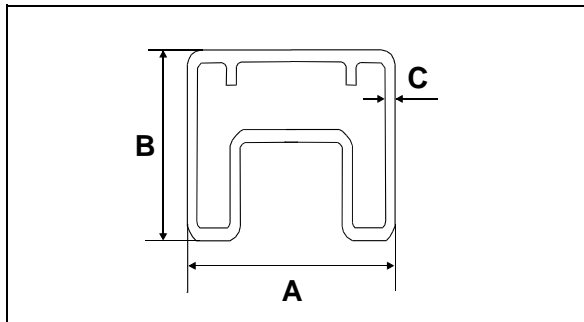

	DIMENSIONS (mm)
	TYP
A	18
B	12
C	0,8
Length tube	532
Quantity per tube	50

Surface mount film taping : contact sales office

PACKAGE MECHANICAL DATA
TO220AB Plastic

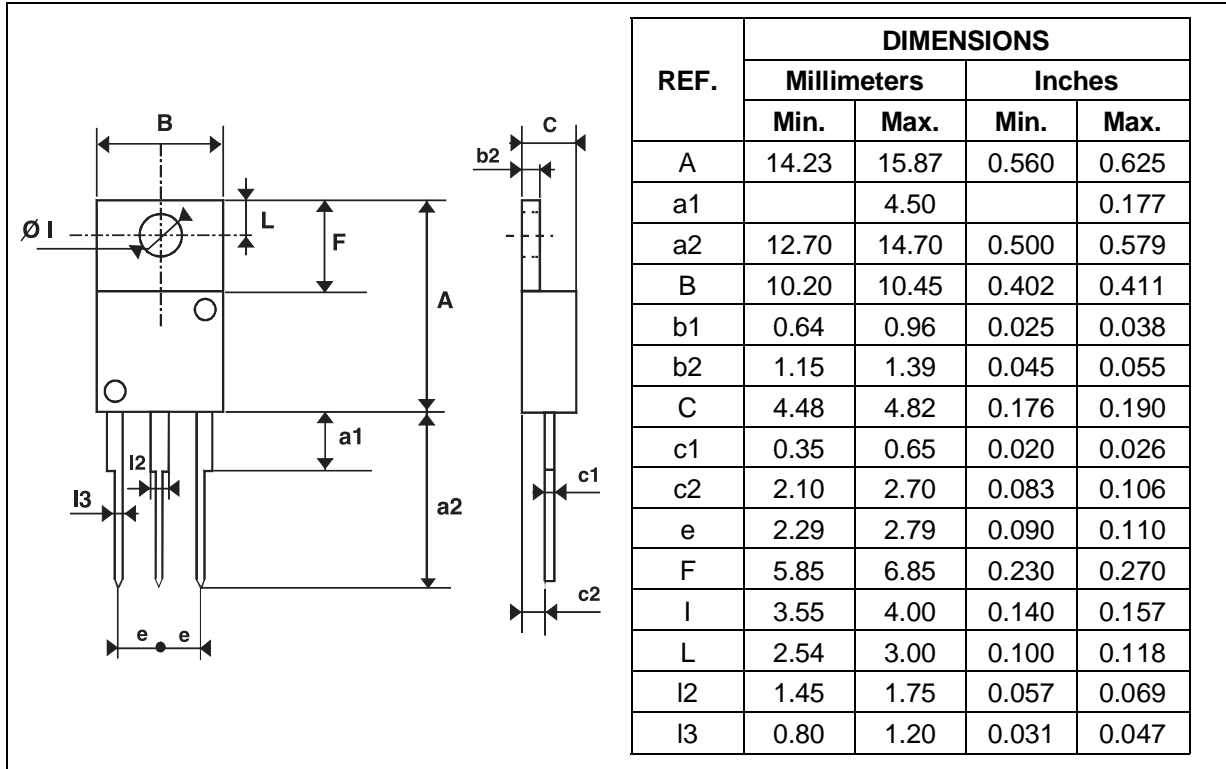

Information furnished is believed to be accurate and reliable. However, SGS-THOMSON Microelectronics assumes no responsibility for the consequences of use of such information nor for any infringement of patents or other rights of third parties which may result from its use. No license is granted by implication or otherwise under any patent or patent rights of SGS-THOMSON Microelectronics. Specifications mentioned in this publication are subject to change without notice. This publication supersedes and replaces all information previously supplied. SGS-THOMSON Microelectronics products are not authorized for use as critical components in life support devices or systems without express written approval of SGS-THOMSON Microelectronics.

© 1997 SGS-THOMSON Microelectronics - Printed in Italy - All rights reserved.

SGS-THOMSON Microelectronics GROUP OF COMPANIES

Australia - Brazil - Canada - China - France - Germany - Italy - Japan - Korea - Malaysia - Malta - Morocco
The Netherlands - Singapore - Spain - Sweden - Switzerland - Taiwan - Thailand - United Kingdom - U.S.A.