



SD56120M

RF POWER TRANSISTORS

The *Ldmo*ST FAMILY

N-CHANNEL ENHANCEMENT-MODE LATERAL MOSFETs

- EXCELLENT THERMAL STABILITY
- COMMON SOURCE CONFIGURATION, PUSH-PULL
- P_{OUT} = 120 W WITH 13 dB gain @ 860 MHz /32V
- BeO FREE PACKAGE
- INTERNAL INPUT MATCHING

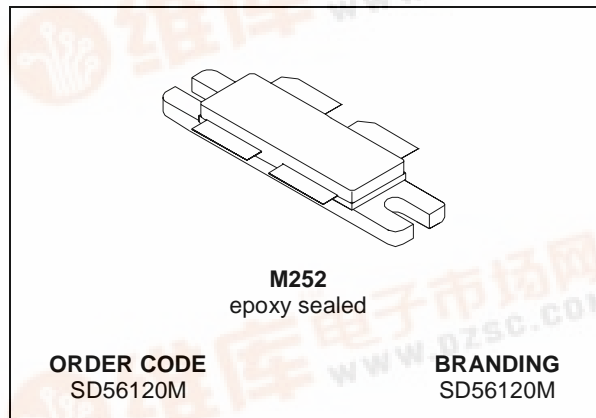

DESCRIPTION

The SD56120M is a common source N-Channel enhancement-mode lateral Field-Effect RF power transistor designed for broadband commercial and industrial applications at frequencies up to 1.0 GHz. The SD56120M is designed for high gain and broadband performance operating in common source mode at 32 V. Its internal matching makes it ideal for TV broadcast applications requiring high linearity.

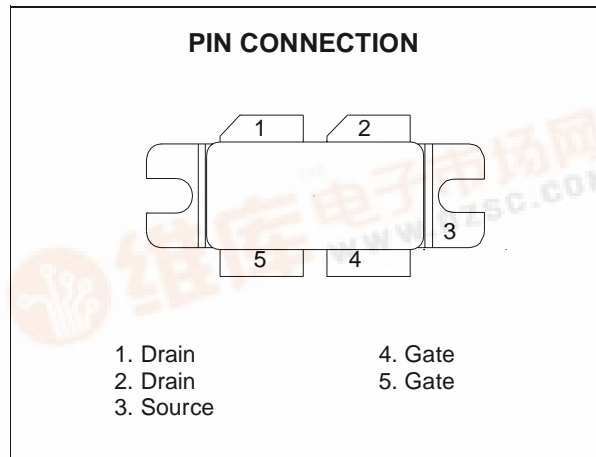

ABSOLUTE MAXIMUM RATINGS (T_{case} = 25°C)

Symbol	Parameter	Value	Unit
V _{(BR)DSS}	Drain-Source Voltage	65	V
V _{GS}	Gate-Source Voltage	± 20	V
I _D	Drain Current	14	A
P _{DISS}	Power Dissipation (@ T _c = 70°C)	236	W
T _j	Max. Operating Junction Temperature	200	°C
T _{STG}	Storage Temperature	-65 to +150	°C

THERMAL DATA

R _{th(j-c)}	Junction -Case Thermal Resistance	0.55	°C/W
----------------------	-----------------------------------	------	------

SD56120M

ELECTRICAL SPECIFICATION (T_{CASE} = 25°C)

STATIC (Per Section)

Symbol	Test Conditions		Min.	Typ.	Max.	Unit
V _{(BR)DSS}	V _{GS} = 0 V	I _{DS} = 10 mA	65			V
I _{DSS}	V _{GS} = 0 V	V _{DS} = 28 V			1	μA
I _{GSS}	V _{GS} = 20 V	V _{DS} = 0 V			1	μA
V _{GS(Q)}	V _{DS} = 28 V	I _D = 100 mA	2.0		5.0	V
V _{DS(ON)}	V _{GS} = 10 V	I _D = 3 A		0.7	0.8	V
G _{FS}	V _{DS} = 10 V	I _D = 3 A		3		mho
C _{ISS} *	V _{GS} = 0 V	V _{DS} = 28 V		221		pF
C _{OSS}	V _{GS} = 0 V	V _{DS} = 28 V		48.9		pF
C _{RSS}	V _{GS} = 0 V	V _{DS} = 28 V		2.25		pF

* Includes Internal Input Moscap.

DYNAMIC

Symbol	Test Conditions				Min.	Typ.	Max.	Unit
P _{OUT}	V _{DD} = 32 V	I _{DQ} = 400 mA		f = 860 MHz	120			W
G _{PS}	V _{DD} = 32 V	I _{DQ} = 400 mA	P _{OUT} = 120 W	f = 860 MHz	13	16		dB
η _D	V _{DD} = 32 V	I _{DQ} = 400 mA	P _{OUT} = 120 W	f = 860 MHz	50			%
Load mismatch	V _{DD} = 32 V	I _{DQ} = 400 mA	P _{OUT} = 120 W	f = 860 MHz	10:1			VSWR
	ALL PHASE ANGLES							

IMPEDANCE DATA

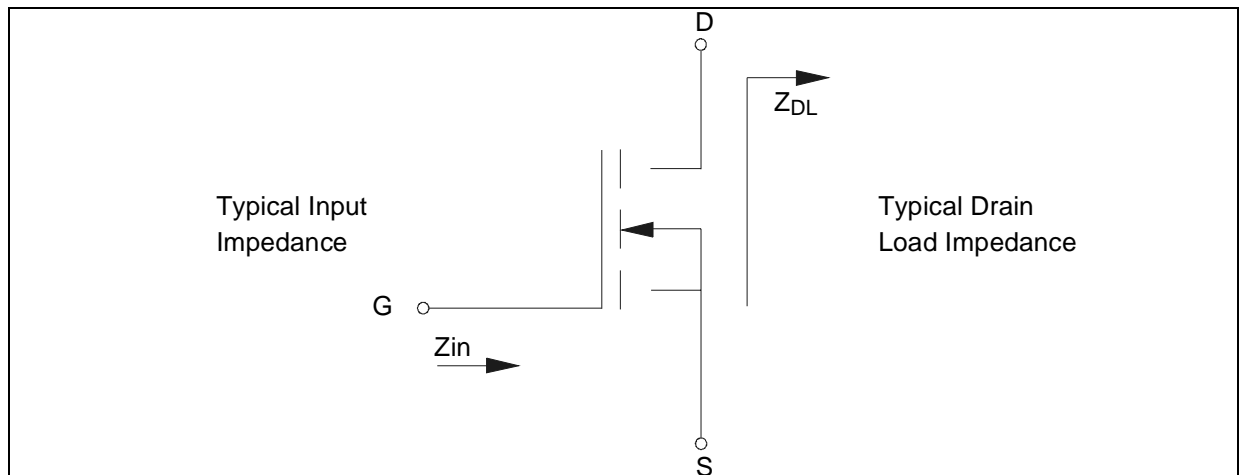

FREQ.	Z _{IN} (Ω)	Z _{DL} (Ω)
860 MHz	5.57 + j 3.488	4.21 - j 2.88

Measured drain to drain and gate to gate respectively.

TYPICAL PERFORMANCE

Capacitance vs. Drain Voltage

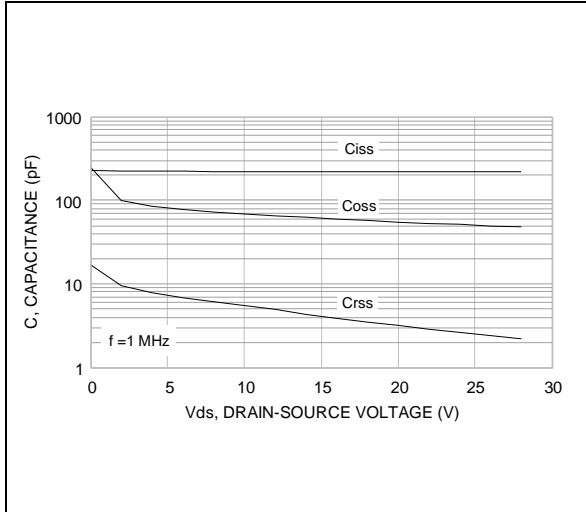

Gate-Source Voltage vs. Case Temperature

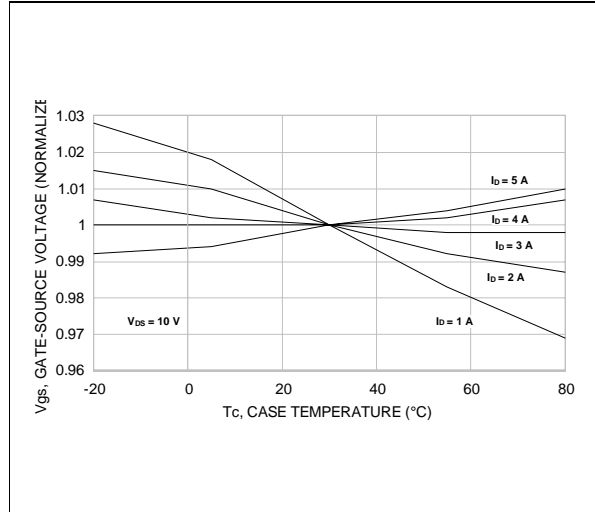

Drain Current vs. Gate Voltage

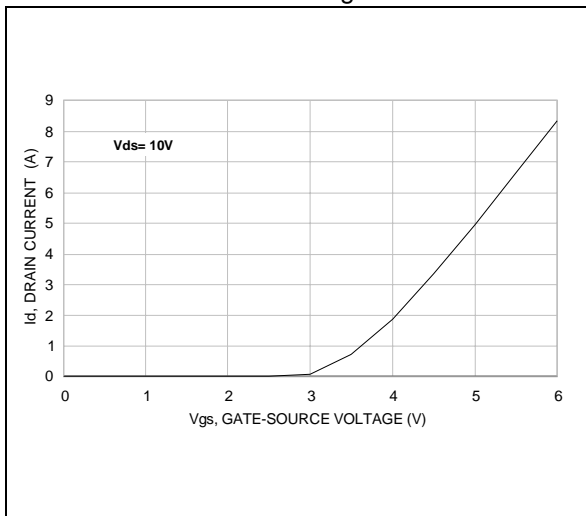

SD56120M

TYPICAL PERFORMANCE

Output Power & Efficiency vs. Input Power

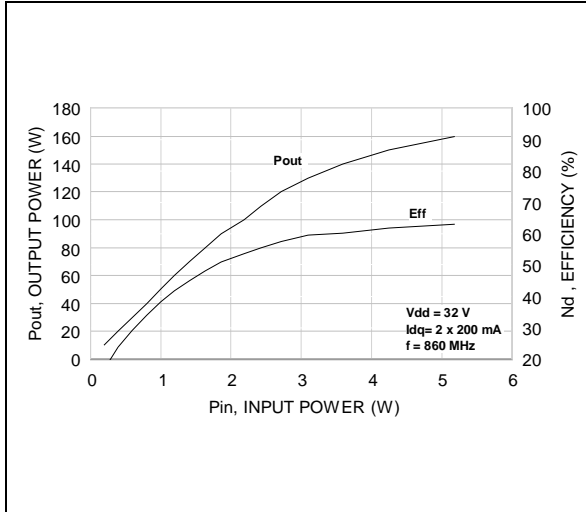

Power Gain vs. Output Power

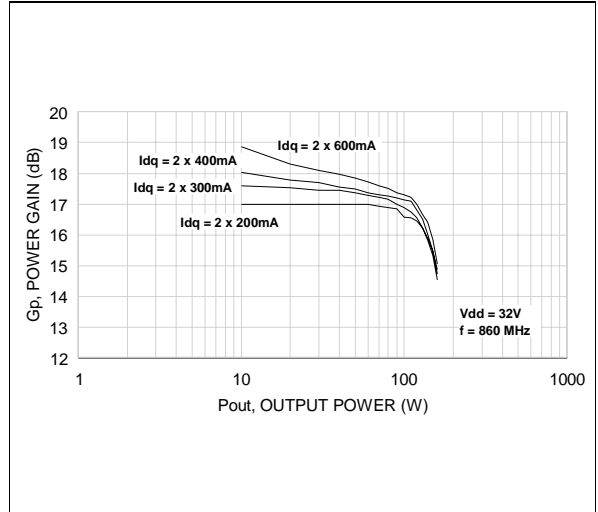

Intermodulation Distortion vs. Output Power

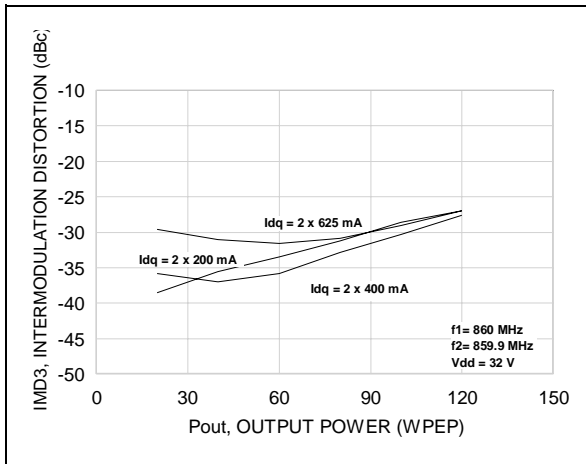

Output Power vs. Drain Voltage

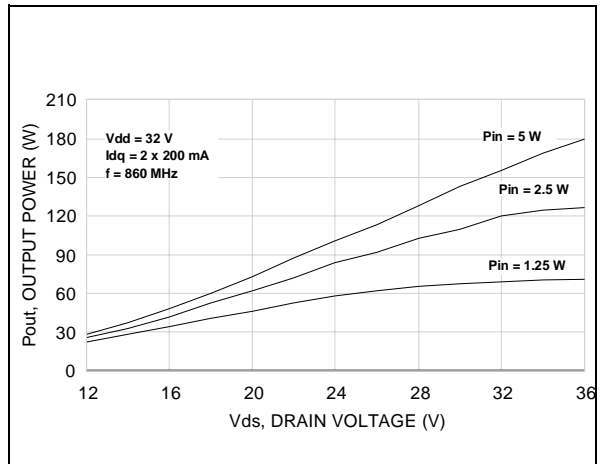

TEST CIRCUIT SCHEMATIC

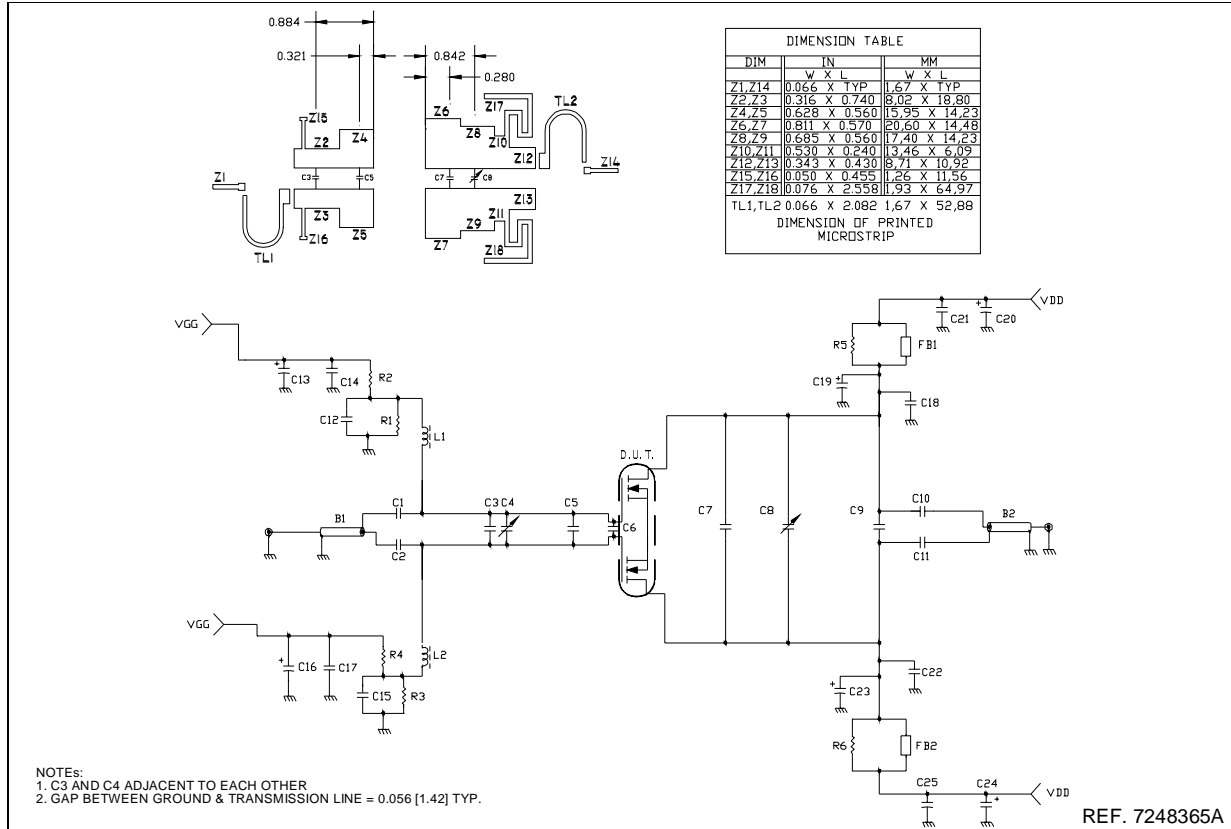

TEST CIRCUIT COMPONENT PART LIST

COMPONENT	DESCRIPTION
C1, C2, C10, C11	51 pF ATC 100B SURFACE MOUNT CERAMIC CHIP CAPACITOR
C3	9.1 pF ATC 100B SURFACE MOUNT CERAMIC CHIP CAPACITOR
C4, C8	0.6 - 4.5 GIGATRIM VARIABLE CAPACITOR
C5, C9	5.6 pF ATC 100B SURFACE MOUNT CERAMIC CHIP CAPACITOR
C6	12 pF ATC 100A SURFACE MOUNT CERAMIC CHIP CAPACITOR
C7	13 pF ATC 100B SURFACE MOUNT CERAMIC CHIP CAPACITOR
C12, C15, C18, C22	91 pF ATC 100B SURFACE MOUNT CERAMIC CHIP CAPACITOR
C13, C16, C20, C24	10 μ F 50V ALUMINUM ELECTROLYTIC RADIAL LEAD CAPACITOR
C14, C17, C21, C25	0.1 μ F 500V SURFACE MOUNT CERAMIC CHIP CAPACITOR
C19, C23	100 μ F 63V ALUMINUM ELECTROLYTIC RADIAL LEAD CAPACITOR
R1, R2, R3, R4	200 OHM 1/4 W SURFACE MOUNT CHIP RESISTOR
R5, R6	1.8 OHM 1/4 W SURFACE MOUNT CHIP RESISTOR
B1, B2	BALUN, 25 OHM SEMI-RIDGE OD="0.141", 2.37 LG COAXIAL CABLE OR EQUIVALENT
L1, L2	CHIP INDICATOR 10 nH SURFACE MOUNT COIL
FB1, FB2	SURFACE MOUNT EMI SHIELD BEAD
PCB	WOVEN GLASS REINFORCED / CERAMIC FILLED 0.030" THK $\epsilon_r = 3.48$, 2 Oz ED CU BOTH SIDES

SD56120M

TEST FIXTURE

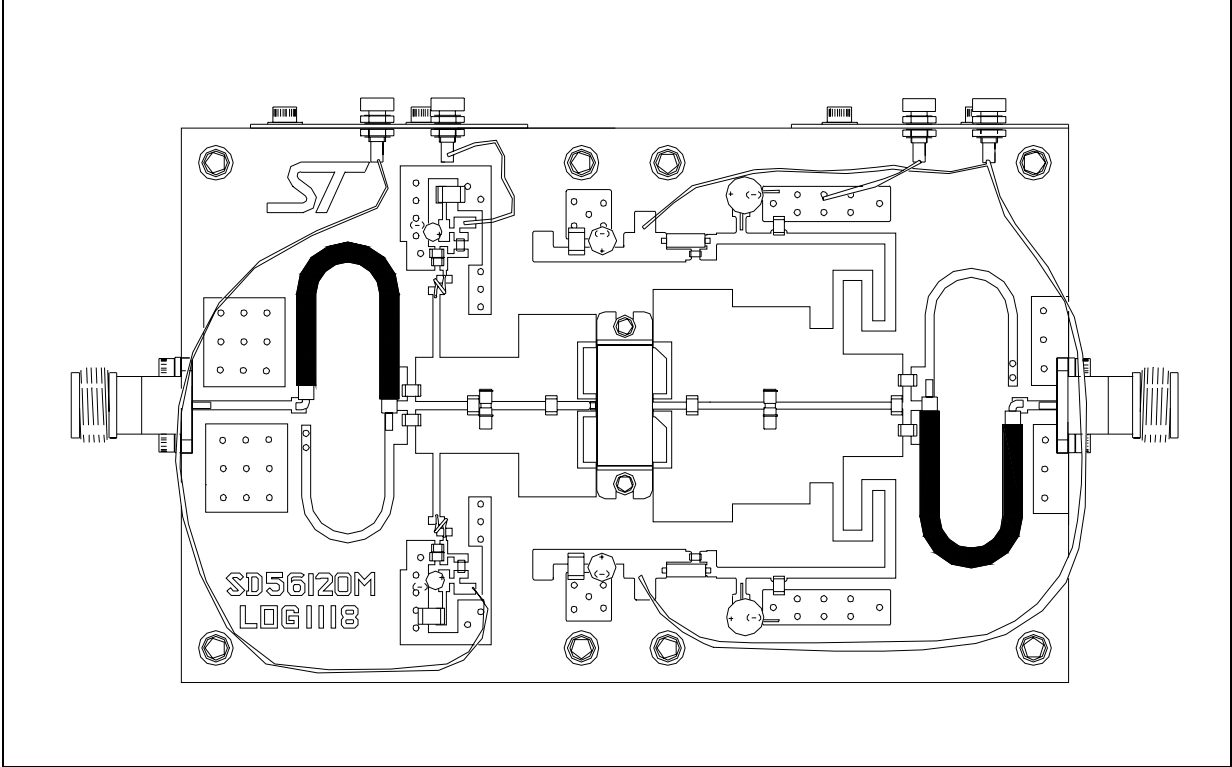

TEST CIRCUIT PHOTOMASTER

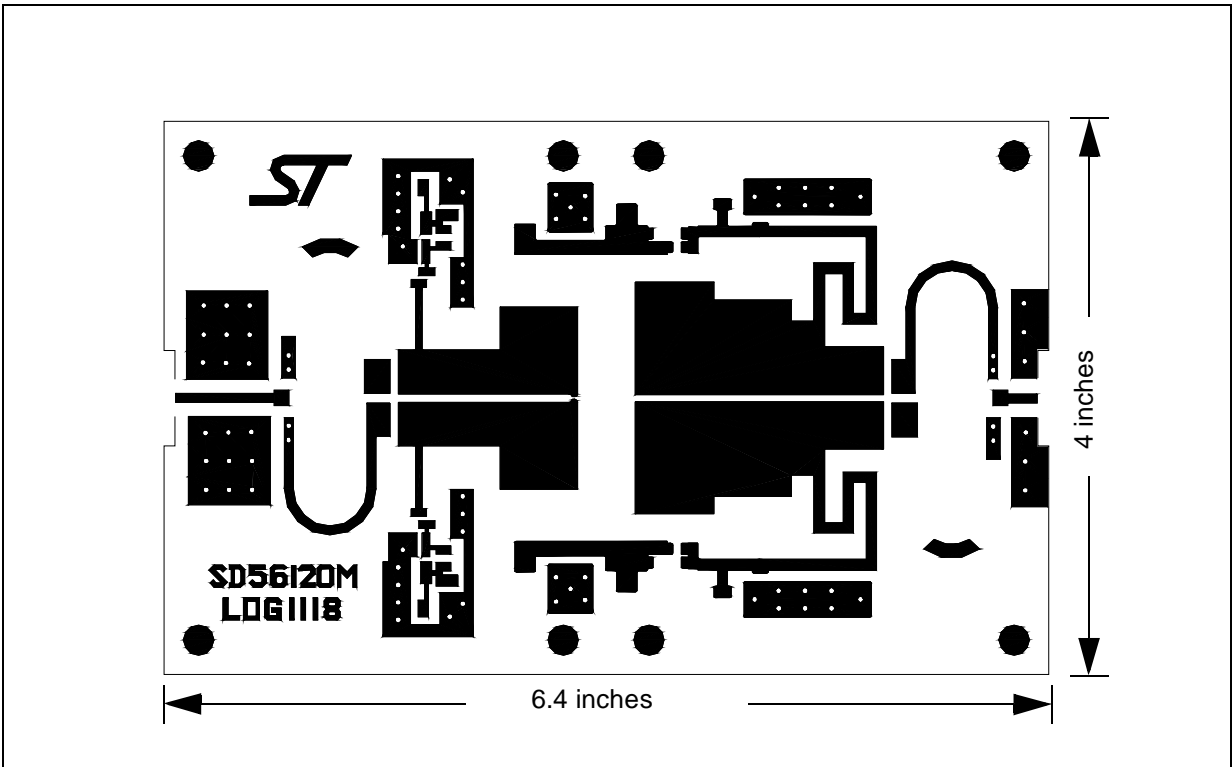

M252 (.400 x .860 4L BAL N/HERM W/FLG) MECHANICAL DATA

DIM.	mm			Inch		
	MIN.	TYP.	MAX	MIN.	TYP.	MAX
A	8.13		8.64	.320		.340
B		10.80			.425	
C	3.00		3.30	.118		.130
D	9.65		9.91	.380		.390
E	2.16		2.92	.085		.115
F	21.97		22.23	.865		.875
G		27.94			1.100	
H	33.91		34.16	1.335		1.345
I	0.10		0.15	.004		.006
J	1.52		1.78	.060		.070
K	2.36		2.74	.093		.108
L	4.57		5.33	.180		.210
M	9.96		10.34	.392		.407
N	21.64		22.05	.852		.868

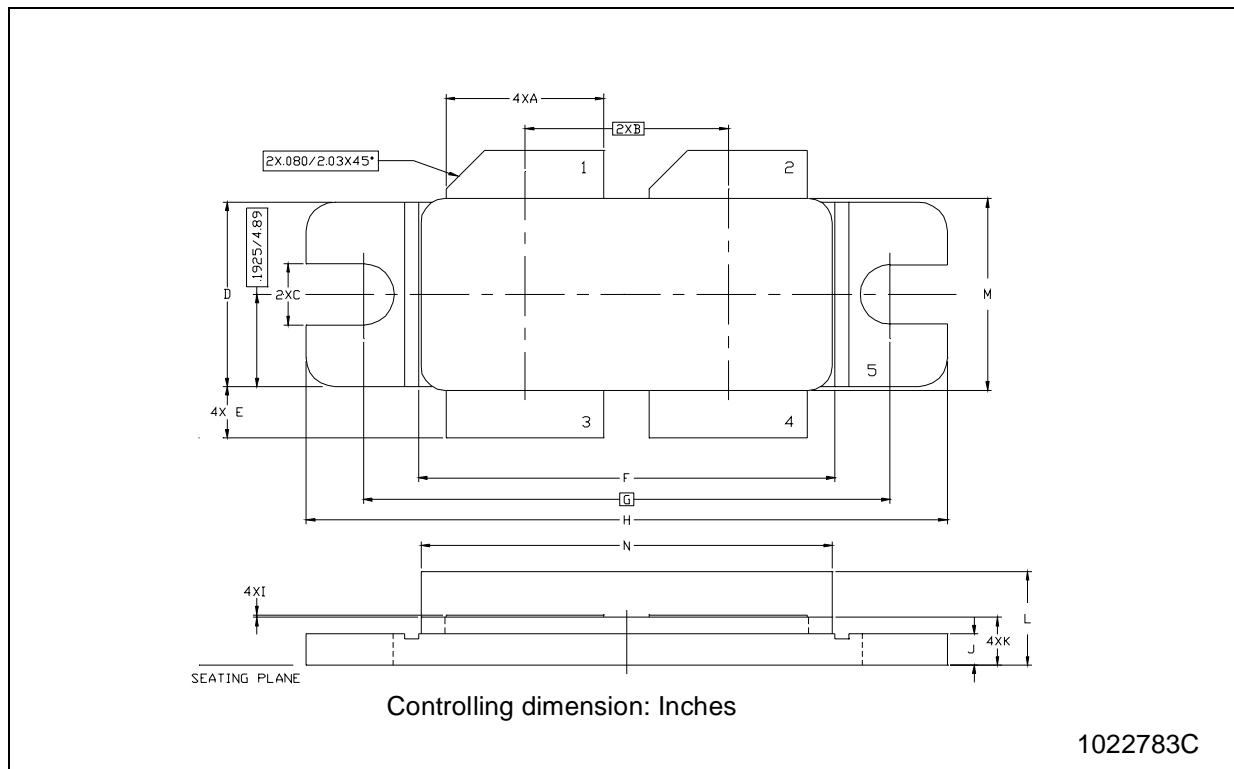

Information furnished is believed to be accurate and reliable. However, STMicroelectronics assumes no responsibility for the consequences of use of such information nor for any infringement of patents or other rights of third parties which may result from its use. No license is granted by implication or otherwise under any patent or patent rights of STMicroelectronics. Specifications mentioned in this publication are subject to change without notice. This publication supersedes and replaces all information previously supplied. STMicroelectronics products are not authorized for use as critical components in life support devices or systems without express written approval of STMicroelectronics.

The ST logo is registered trademark of STMicroelectronics
© 2003 STMicroelectronics - All Rights Reserved

All other names are the property of their respective owners.

Australia - Brazil - Canada - China - Finland - France - Germany - Hong Kong - India - Israel - Italy - Japan -
Malaysia - Malta - Morocco - Singapore - Spain - Sweden - Switzerland - United Kingdom - U.S.A.
<http://www.st.com>