



AWT6114

KPCS CDMA 3.4V/28dBm
Linear Power Amplifier Module

ADVANCED PRODUCT INFORMATION - Rev.0.0

FEATURES

- InGaP HBT Technology
- High Efficiency: 37%
- Low Quiescent Current: 55 mA
- Low Leakage Current in Shutdown Mode: $<5 \mu\text{A}$
- Optimized for a 50Ω System
- Low Profile Miniature Surface Mount Package
- CDMA 1XRTT Compliant
- CDMA 1xEV-DO Compliant

APPLICATIONS

- Korean Band PCS CDMA Wireless Handsets

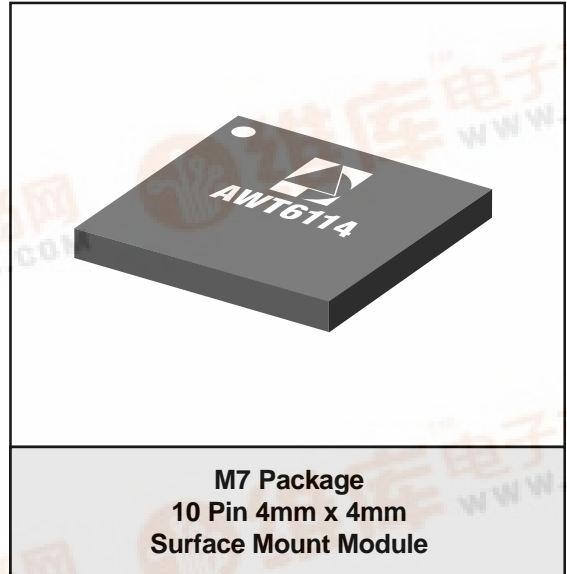

PRODUCT DESCRIPTION

The AWT6114 is a high power, high efficiency amplifier module for Korean Band PCS CDMA wireless handset applications. The device is manufactured on an advanced InGaP HBT MMIC technology offering state-of-the-art reliability, temperature stability, and ruggedness. Selectable bias modes that optimize efficiency for different

output power levels, and a shutdown mode with low leakage current, serve to increase handset talk and standby time. The self-contained 4mm x 4mm surface mount package incorporates matching networks optimized for output power, efficiency and linearity in a 50Ω system.

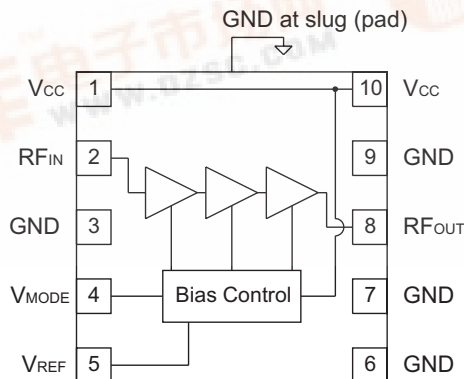

Figure 1: Block Diagram



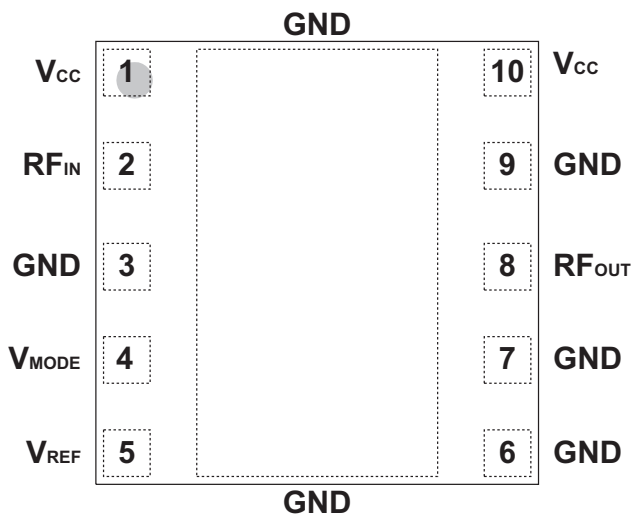

Figure 2: Pinout (X-ray Top View)

Table 1: Pin Description

PIN	NAME	DESCRIPTION
1	V_{CC}	Supply Voltage
2	RF_{IN}	RF Input
3	GND	Ground
4	V_{MODE}	Mode Control Voltage
5	V_{REF}	Reference Voltage
6	GND	Ground
7	GND	Ground
8	RF_{OUT}	RF Output
9	GND	Ground
10	V_{CC}	Supply Voltage

ELECTRICAL CHARACTERISTICS

Table 2: Absolute Minimum and Maximum Ratings

PARAMETER	MIN	MAX	UNIT
Supply Voltage (V_{CC})	0	+5	V
Mode Control Voltage (V_{MODE})	0	+3.5	V
Reference Voltage (V_{REF})	0	+3.5	V
RF Input Power (P_{IN})	-	+10	dBm
Storage Temperature (T_{STG})	-40	+150	°C

Stresses in excess of the absolute ratings may cause permanent damage. Functional operation is not implied under these conditions. Exposure to absolute ratings for extended periods of time may adversely affect reliability.

Table 3: Operating Ranges

PARAMETER	MIN	TYP	MAX	UNIT	COMMENTS
Operating Frequency (f)	1750	-	1780	MHz	
Supply Voltage (V_{CC})	+3.0	+3.4	+4.2	V	
Reference Voltage (V_{REF})	+2.75 0	+2.85 -	+3.1 +0.5	V	PA "on" PA "shut down"
Mode Control Voltage (V_{MODE})	+2.5 0	+2.85 -	+3.1 +0.5	V	Low Bias Mode High Bias Mode
RF Output Power (P_{OUT})	-	+28.0	-	dBm	
Case Temperature (T_C)	-30	-	+110	°C	

The device may be operated safely over these conditions; however, parametric performance is guaranteed only over the conditions defined in the electrical specifications.

AWT6114

Table 4: Electrical Specifications
(T_C = +25 °C, V_{CC} = +3.4 V, V_{REF} = +2.85 V, 50 Ω system)

PARAMETER	MIN	TYP	MAX	UNIT	COMMENTS
Gain	-	29 27	-	dB	P _{OUT} = +28 dBm, V _{MODE} = 0 V P _{OUT} = +16 dBm, V _{MODE} = +2.85 V
Adjacent Channel Power at ±1.25 MHz offset Primary Channel BW = 1.23 MHz Adjacent Channel BW = 30 kHz	-	-52 -48	-	dB	P _{OUT} = +28 dBm, V _{MODE} = 0 V P _{OUT} = +16 dBm, V _{MODE} = +2.85 V
Adjacent Channel Power at ±2.25 MHz offset Primary Channel BW = 1.23 MHz Adjacent Channel BW = 30 kHz	-	-59 -62	-	dB	P _{OUT} = +28 dBm, V _{MODE} = 0 V P _{OUT} = +16 dBm, V _{MODE} = +2.85 V
Power-Added Efficiency	-	37 7.5	-	%	P _{OUT} = +28 dBm, V _{MODE} = 0 V P _{OUT} = +16 dBm, V _{MODE} = +2.85 V
Quiescent Current (I _{cq})	-	55	-	mA	V _{MODE} = +2.85 V
Reference Current	-	7	10	mA	through V _{REF} pin
Mode Control Current	-	0.35	0.7	mA	through V _{MODE} pin
Leakage Current	-	<5	-	μA	V _{CC} = +3.4 V, V _{REF} = 0 V, V _{MODE} = 0 V
Noise in Receive Band	-	-135	-	dBm/Hz	1840 MHz to 1870MHz
Harmonics 2fo 3fo, 4fo	-	-41 -65	-30 -30	dBc	
Input Impedance	-	-	2:1	VSWR	
Spurious Output Level (all spurious outputs)	-	-	-70	dBc	P _{OUT} ≤ +28 dBm In-band load VSWR < 8:1 Out-of-band load VSWR < 8:1 Applies over all voltage and temperature operating ranges
Load mismatch stress with no permanent degradation or failure	8:1	-	-	VSWR	V _{CC} = +5.0 V, P _{IN} = +5 dBm Applies over full operating temperature range

APPLICATION INFORMATION

To ensure proper performance, refer to all related Application Notes on the ANADIGICS web site: <http://www.anadigics.com>

Shutdown Mode

The power amplifier may be placed in a shutdown mode by applying logic low levels (see Operating Ranges table) to both the V_{REF} and V_{MODE} voltages.

Bias Modes

The power amplifier may be placed in either a Low Bias mode or a High Bias mode by applying the appropriate logic level (see Operating Ranges table) to the V_{MODE} voltage. The Bias Control table lists the recommended modes of operation for various applications.

Table 5: Bias Control

APPLICATION	P_{OUT} LEVELS	BIAS MODE	V_{REF}	V_{MODE}
CDMA - low power	$\leq +16$ dBm	Low	+2.85 V	+2.85 V
CDMA - high power	$> +16$ dBm	High	+2.85 V	0 V
Shutdown	-	Shutdown	0 V	0 V

AWT6114

PACKAGE OUTLINE

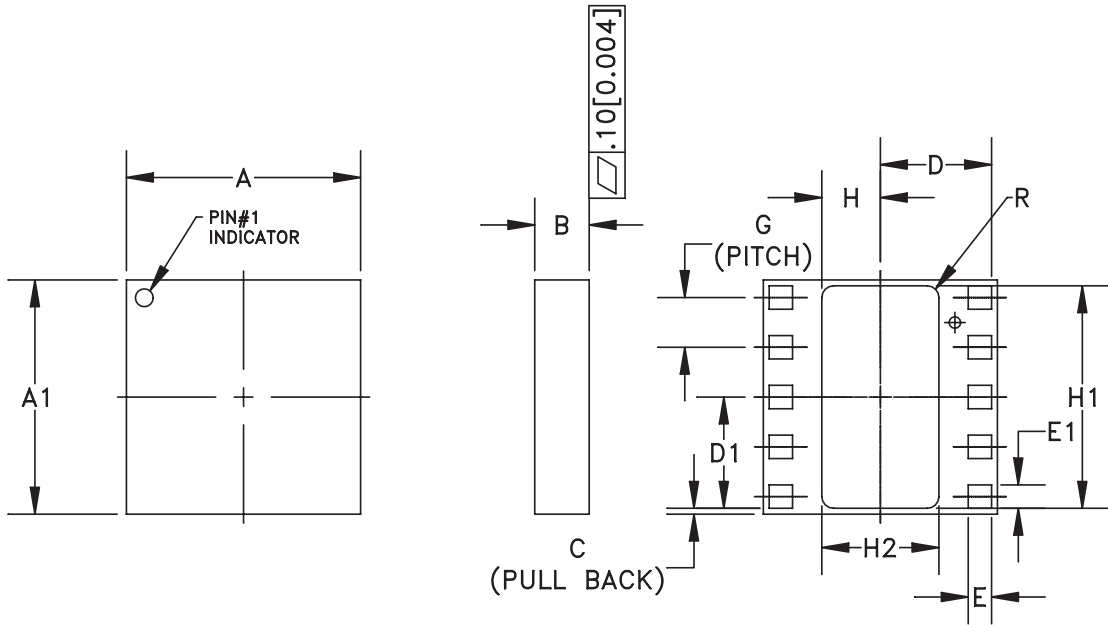

SYMBOL	MILLIMETERS			INCHES			NOTE
	MIN.	NOM.	MAX.	MIN.	NOM.	MAX.	
A	3.88	4.00	4.12	0.152	0.157	0.162	-
A1	3.88	4.00	4.12	0.152	0.157	0.162	-
B	1.30	1.55	1.70	0.051	0.061	0.067	3
C	-	0.10	-	-	0.004	-	-
D	-	1.90	-	-	0.075	-	-
D1	-	1.90	-	-	0.075	-	-
E	0.35	0.40	0.45	0.013	0.015	0.017	-
E1	0.35	0.40	0.45	0.013	0.015	0.017	-
G	0.85 BSC			0.033 BSC			-
H	-	1.00	-	-	0.039	-	-
H1	-	3.80	-	-	0.149	-	-
H2	-	2.00	-	-	0.078	-	-
R	-	0.20	-	-	0.007	-	-

NOTES:

1. CONTROLLING DIMENSIONS: MILLIMETERS
2. UNLESS SPECIFIED TOLERANCE=±0.076[0.003].
3. REFERENCE ONLY.

Figure 3: M7 Package Outline - 10 Pin 4mm x 4mm Surface Mount Module

NOTES



ANADIGICS, Inc.

141 Mount Bethel Road

Warren, New Jersey 07059, U.S.A.

Tel: +1 (908) 668-5000

Fax: +1 (908) 668-5132

URL: <http://www.anadigics.com>

E-mail: Mktg@anadigics.com

IMPORTANT NOTICE

ANADIGICS, Inc. reserves the right to make changes to its products or to discontinue any product at any time without notice. The product specifications contained in Advanced Product Information sheets and Preliminary Data Sheets are subject to change prior to a product's formal introduction. Information in Data Sheets have been carefully checked and are assumed to be reliable; however, ANADIGICS assumes no responsibilities for inaccuracies. ANADIGICS strongly urges customers to verify that the information they are using is current before placing orders.

WARNING

ANADIGICS products are not intended for use in life support appliances, devices or systems. Use of an ANADIGICS product in any such application without written consent is prohibited.