



Reverse Amplifier with Step Attenuator
Data Sheet - Rev 2.0

FEATURES

- Low cost integrated monolithic GaAs amplifier with step attenuator
- Attenuation Range: 0-30 dB, adjustable in 2dB increments via a 4 wire parallel control
- Meets DOCSIS distortion requirements at +58dBmV output signal level
- Low distortion and low noise
- Low signal to noise ratio at all gain levels
- Frequency range: 5-100MHz
- 5 Volt operation

APPLICATIONS

- MCNS/DOCSIS Compliant Cable Modems
- CATV Interactive Set-Top Box
- OpenCable Set-Top Box
- Fiber Nodes
- Cable Modem Termination Systems (CMTS)



PRODUCT DESCRIPTION

The ARA05050 is a GaAs IC designed to provide the reverse path amplification and output level control functions in a CATV Set-Top Box or Cable Modem. It incorporates a digitally controlled precision step attenuator that is preceded by an ultra low noise amplifier stage, and followed by an ultra-linear output driver amplifier. This device is capable of meeting the MCNS/DOCSIS requirements for harmonic

performance at a +58dBmV output level while requiring only a single polarity +5V supply. Both the input and the output are single-ended and matched to 75 Ohms. The precision attenuator provides up to 30 dB of attenuation in 2 dB increments. The ARA05050 is offered in a 28-pin SSOP package featuring a heat slug on the bottom of the package.

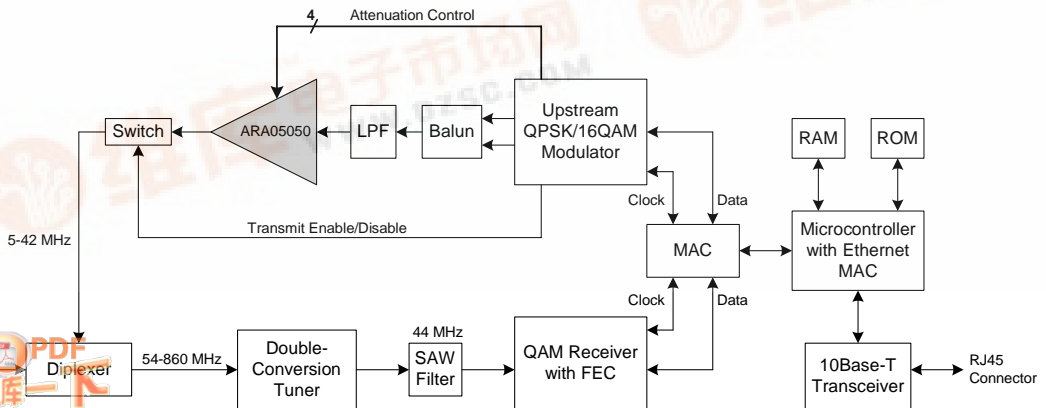

Figure 1. Cable Modem or Set Top Box Application Diagram



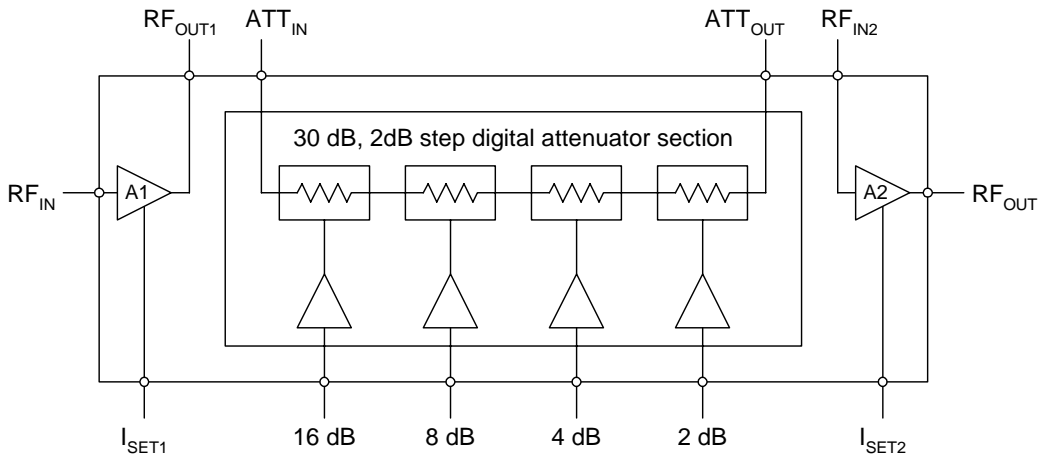

Figure 2: Functional Block Diagram

1	<input type="checkbox"/>	N/C	<input type="checkbox"/>	N/C	28
2	<input type="checkbox"/>	Bypass	<input type="checkbox"/>	N/C	27
3	<input type="checkbox"/>	ATT_IN	<input type="checkbox"/>	ATT_OUT	26
4	<input type="checkbox"/>	RF_OUT1	<input type="checkbox"/>	I_SET2	25
5	<input type="checkbox"/>	V_REF1	<input type="checkbox"/>	RF_IN2	24
6	<input type="checkbox"/>	ATT_ACG1	<input type="checkbox"/>	ATT_ACG2	23
7	<input type="checkbox"/>	ATT_ACG1	<input type="checkbox"/>	ATT_ACG2	22
8	<input type="checkbox"/>	ATT_ACG1	<input type="checkbox"/>	ATT_ACG2	21
9	<input type="checkbox"/>	ATT_ACG1	<input type="checkbox"/>	ATT_ACG2	20
10	<input type="checkbox"/>	RF_IN	<input type="checkbox"/>	V_REF2	19
11	<input type="checkbox"/>	I_SET1	<input type="checkbox"/>	RF_OUT	18
12	<input type="checkbox"/>	V_ATT	<input type="checkbox"/>	GND	17
13	<input type="checkbox"/>	16 dB	<input type="checkbox"/>	2 dB	16
14	<input type="checkbox"/>	8 dB	<input type="checkbox"/>	4 dB	15

Figure 3: Pin Out

Table 1: Pin Description

PIN	NAME	DESCRIPTION	PIN	NAME	DESCRIPTION
1	N/C	No Connection ⁽¹⁾	15	4 dB	4 dB Attenuation Control Bit
2	Bypass	Internal bypass	16	2 dB	2 dB Attenuation Control Bit
3	ATT _{IN}	Attenuator Input ⁽²⁾	17	GND	Ground
4	RF _{OUT1}	Amplifier A1 Output and Supply	18	RF _{OUT}	Amplifier A2 Output and Supply
5	V _{REF1}	Reference Voltage for Amplifier A1	19	V _{REF2}	Reference Voltage for Amplifier A2
6	ATT _{ACG1}	Attenuator AC Ground 1 ⁽³⁾	20	ATT _{ACG2}	Attenuator AC Ground 2 ⁽³⁾
7	ATT _{ACG1}	Attenuator AC Ground 1 ⁽³⁾	21	ATT _{ACG2}	Attenuator AC Ground 2 ⁽³⁾
8	ATT _{ACG1}	Attenuator AC Ground 1 ⁽³⁾	22	ATT _{ACG2}	Attenuator AC Ground 2 ⁽³⁾
9	ATT _{ACG1}	Attenuator AC Ground 1 ⁽³⁾	23	ATT _{ACG2}	Attenuator AC Ground 2 ⁽³⁾
10	RF _{IN}	Amplifier A1 Input ⁽⁴⁾	24	RF _{IN2}	Amplifier A2 Input ⁽⁴⁾
11	I _{SET1}	Amplifier A1 Current Adjust ⁽⁴⁾	25	I _{SET2}	Amplifier A2 Current Adjust ⁽⁴⁾
12	V _{ATT}	Attenuator Supply	26	ATT _{OUT}	Attenuator Output ⁽²⁾
13	16 dB	16 dB Attenuation Control Bit	27	N/C	No Connection ⁽¹⁾
14	8 dB	82 dB Attenuation Control Bit	28	N/C	No Connection ⁽¹⁾

Notes:

(1) All N/C pins should be grounded.

(2) Pins should be AC-coupled. No external DC bias should be applied.

(3) Pins should be AC-grounded. No external DC bias should be applied.

(4) Pins should be grounded or pulled to ground through a resistor. No external DC bias should be applied.

ELECTRICAL CHARACTERISTICS

Table 2: Absolute Minimum and Maximum Ratings

PARAMETER	MIN	MAX	UNIT
Analog Supply: V_{SUP} (pins 4, 12, 18)	0	9	VDC
Amplifier Reference Voltages (pins 5, 19)	-2.5	$\frac{V_{SUP}}{2}$	VDC
RF Power at Amplifier Inputs (pins 10, 24)	-	+60	dBmV
Attenuator Controls (pins 13, 14, 15, 16)	0	6	V
Storage Temperature	-55	+200	°C
Soldering Temperature	-	260	°C
Soldering Time	-	5	Sec

Stresses in excess of the absolute ratings may cause permanent damage. Functional operation is not implied under these conditions. Exposure to absolute ratings for extended periods of time may adversely affect reliability.

Notes:

1. Pins 3 and 26 should be AC-coupled. No external DC bias should be applied.
2. Pins 10, 11, 24 and 25 should be grounded or pulled to ground through a resistor. No external DC bias should be applied.
3. Pins 6, 7, 8, 9, 20, 21, 22 and 23 should be AC-grounded. No external DC bias should be applied.

Table 3: Operating Ranges

PARAMETER	MIN	TYP	MAX	UNIT
Amplifier Supply: V_{DD} (pins 4, 18)	4.5	5	7	VDC
Attenuator Supply: V_{ATTN} (pin 12)	$V_{DD}-0.5$	5	7	VDC
Attenuator Controls (pins 13, 14, 15, 16)	0	-	5.5	V
Amplifier Reference Voltages (pins 5, 19)	-	1.75	-	VDC
Case Temperature	-40	25	85	°C

The device may be operated safely over these conditions; however, parametric performance is guaranteed only over the conditions defined in the electrical specifications.

Table 4: DC Electrical Specifications $T_A=25^{\circ}\text{C}$; $V_{DD}, V_{ATTN} = +5.0\text{ VDC}$

PARAMETER	MIN	TYP	MAX	UNIT
Amplifier A1 Current (pin 4)	-	75	95	mA
Amplifier A2 Current (pin 18)	-	100	130	mA
Attenuator Current (pin 12)	-	8	-	mA
Total Power Consumption	-	0.92	1.2	W

Table 5: AC Electrical Specifications $T_A=25^{\circ}\text{C}$; $V_{DD}, V_{ATTN} = +5.0\text{ VDC}$

PARAMETER	MIN	TYP	MAX	UNIT	COMMENTS
Gain (10 MHz)	30	32	33	dB	0 dB attenuation setting
Gain Flatness	-	0.75	1.5	dB	5 to 100 MHz
Gain Variation over Temperature	-	-0.006	-	dB/°C	
Attenuation Steps					
2 dB	1.6	1.85	2.2	dB	5 to 42 MHz ⁽¹⁾ , Monotonic
4 dB	3.8	4.0	4.2		
8 dB	8.0	8.3	8.5		
16 dB	16.0	16.6	17.0		
2 nd Harmonic Distortion Level					
5 MHz	-	-60	-55	dBc	+58 dBmV into 75 Ohms
25 MHz	-	-63	-55		
3 rd Harmonic Distortion Level					
5 MHz	-	-63	-60	dBc	+58 dBmV into 75 Ohms
25 MHz	-	-63	-60		
3 rd Order Output Intercept	78	-	-	dBmV	
1 dB Gain Compression Point	-	70	-	dBmV	
Noise Figure	-	1.7	2.5	dB	

Notes:

(1) See Figures 5 and 6 for performance at higher frequencies.

All specifications as measured in ANADIGICS test fixture.

continued: AC Electrical Specifications

T_A=25°C; V_{DD}, V_{ATTN} = +5.0 VDC

PARAMETER	MIN	TYP	MAX	UNIT	COMMENTS
Output Noise Power Active / No Signal / Min. Atten. Set. Active / No Signal / Max. Atten. Set.	- -	- -	-37.6 -54.6	dBmV	Any 160 kHz bandwidth from 5 to 42 MHz
Input Impedance	-	75	-	Ohms	
Input Return Loss	-	-20	-15	dB	75 Ohm system
Output Impedance	-	75	-	Ohms	
Output Return Loss	-	-20	-15	dB	75 Ohm system

Note: As measured in ANADIGICS test fixture

Table 6: Logic Interface Specifications

T_A=25°C; V_{DD}, V_{ATTN} = +5.0 VDC

PARAMETER	MIN	TYP	MAX	UNIT	COMMENTS
Attenuator Control Logic ⁽¹⁾ V _{IN,LOW} V _{IN,HIGH}	0 2.8	- -	0.5 5.5	V	Bypasses atten. stage Enables atten. stage
Attenuator Control Impedance	-	5K	-	Ohms	

Note:

(1) Specification applies when 470 Ohm resistor is connected from pin 2 to ground (see test circuit in Figure 4).

Table 7: Attenuator Logic

ATTENUATION (dB)	0	2	4	6	8	10	12	14	16	18	20	22	24	26	28	30
2 dB Logic Input (pin 16)	L	H	L	H	L	H	L	H	L	H	L	H	L	H	L	H
4 dB Logic Input (pin 15)	L	L	H	H	L	L	H	H	L	L	H	H	L	L	H	H
8 dB Logic Input (pin 14)	L	L	L	L	H	H	H	H	L	L	L	L	H	H	H	H
16 dB Logic Input (pin 13)	L	L	L	L	L	L	L	L	H	H	H	H	H	H	H	H

Note: "L" = logic low, "H" = logic high

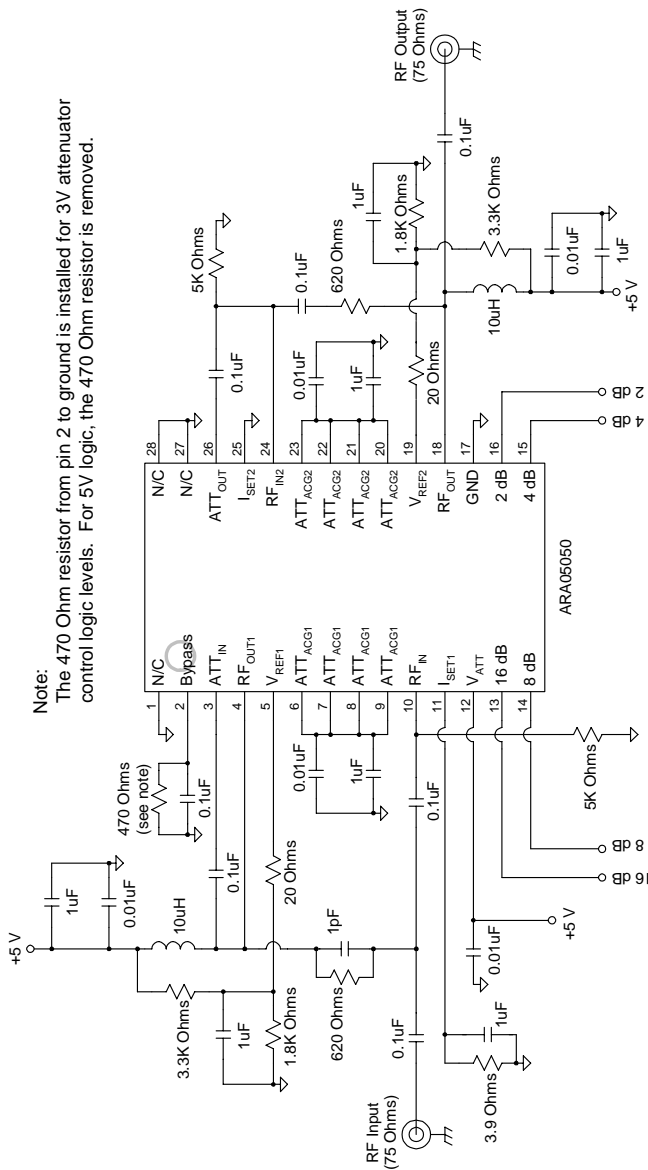

Note:
The 470 Ohm resistor from pin 2 to ground is installed for 3V attenuator control logic levels. For 5V logic, the 470 Ohm resistor is removed.

Figure 4: Test Circuit

ARA05050

PERFORMANCE DATA

Figure 5: S21 (0 - 16 dB Attenuation)

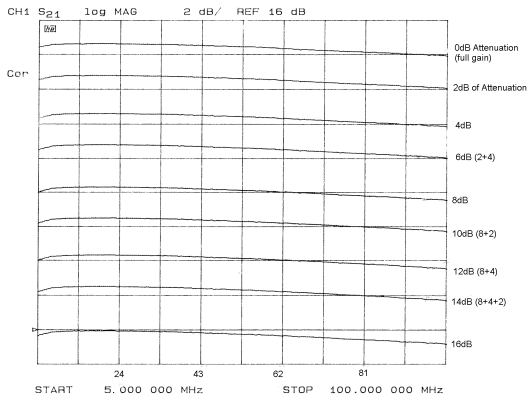

Figure 6: S21 (16 - 30 dB Attenuation)

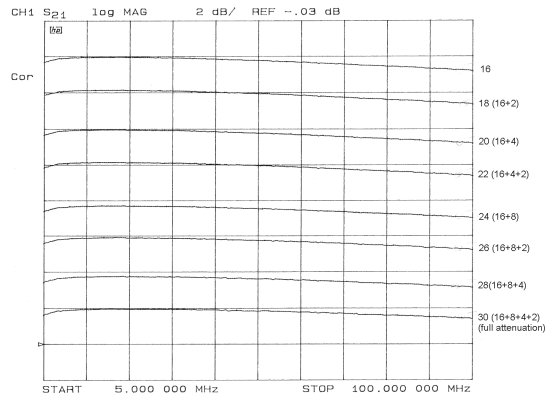

Figure 7: S11 - Log Scale

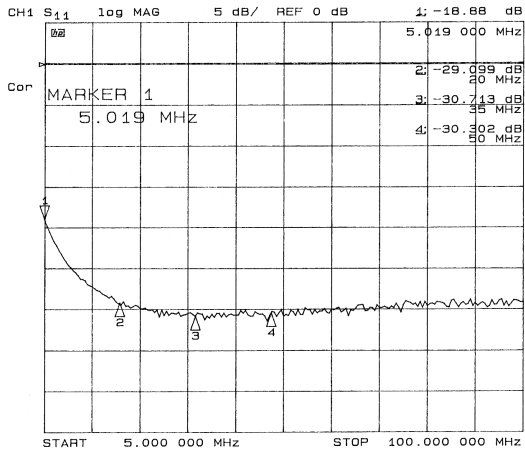

Figure 8: S22 - Log Scale

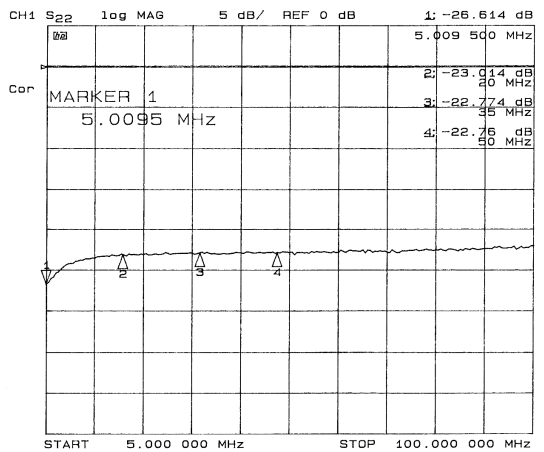

Figure 9: S11 - Smith Chart

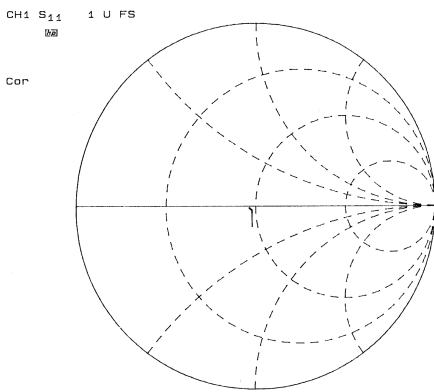

Figure 10: S22 - Smith Chart

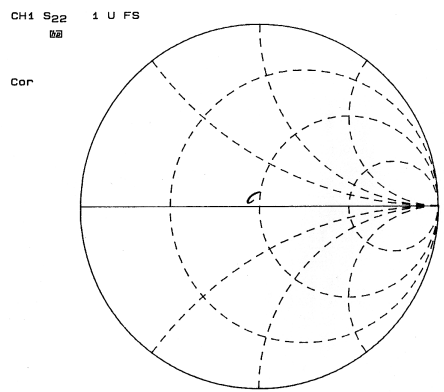

Figure 11: Attenuator Switching Speed - 16 dB Step

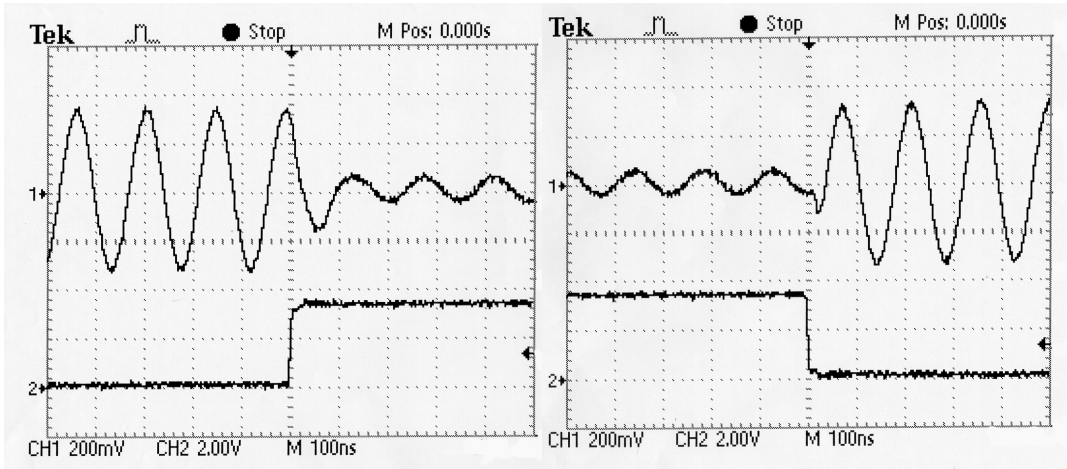
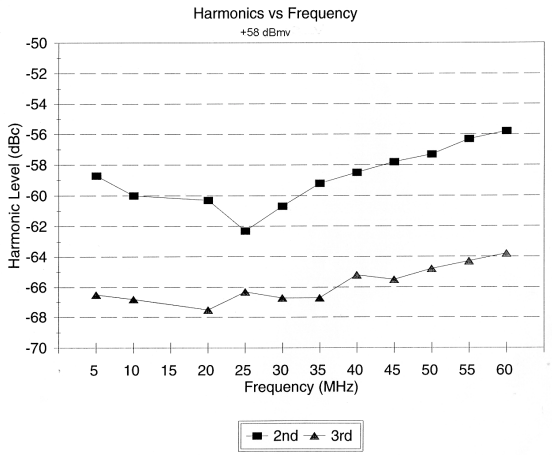

Figure 12: Harmonic Performance



ARA05050

APPLICATION INFORMATION

Printed Circuit Board Layout Considerations

The ARA05050 is a high-performance RF device. Special consideration must be given to certain features of the the printed circuit board layout, as they can affect the RF performance of the IC. Refer to the ANADIGICS application note “CATV Reverse Amp w/ Step Attenuator” for more details.

Amplifier Enable / Disable

The ARA05050 includes two amplification stages that each can be shut down through external control pins V_{REF1} and V_{REF2} (pins 5 and 19, respectively.) By applying a typical bias of 1.75 Volts to these pins, the amplifiers are enabled. In order to fully disable an amplifier, its control pin requires a negative bias of -1.5 to -2.0 Volts.

Amplifier Bias Current

The I_{SET} pins (11 and 25) set the bias current for the amplification stages. Grounding these pins results in the maximum possible current. By placing a resistor from the pin to ground, the current can be reduced. The recommended bias conditions use the configuration shown in the test circuit schematic in Figure 4.

Thermal Layout Considerations

The device package for the ARA05050 features a heat slug on the bottom of the package body. Use of the heat slug is an integral part of the device design. Soldering it to the ground plane of the PC board will ensure the lowest possible thermal resistance for the device, and will result in the longest MTF (mean time to failure.)

A PC board layout that optimizes the benefits of the heat slug is shown in Figure 13. The via holes located under the body of the device must be plated through to a ground plane layer of metal, in order to provide sufficient thermal conductivity. The recommended solder mask outline is shown in Figure 14.

ESD Sensitivity

Electrostatic discharges can cause permanent damage to this device. Electrostatic charges accumulate on test equipment and the human body, and can discharge without detection. Proper precautions and handling are strongly recommended. Refer to the ANADIGICS application note on ESD precautions.

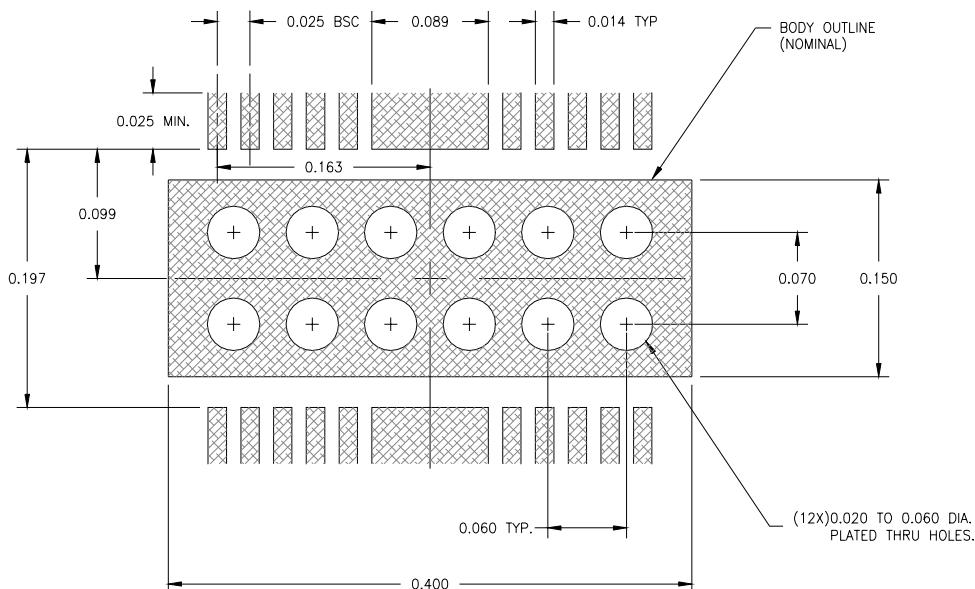

Figure 13: PC Board Layout

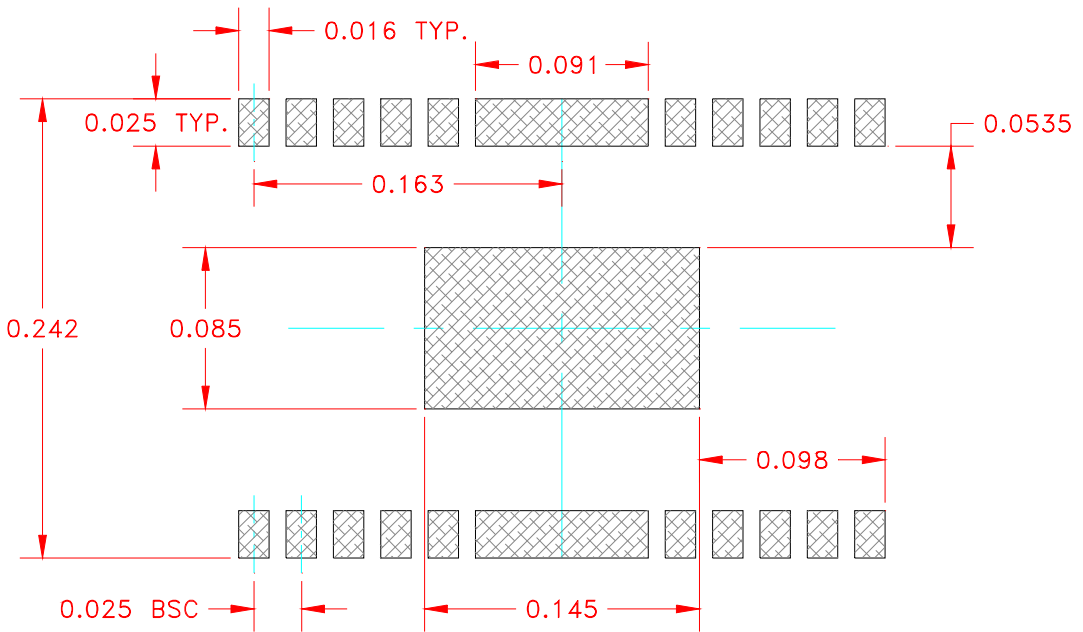
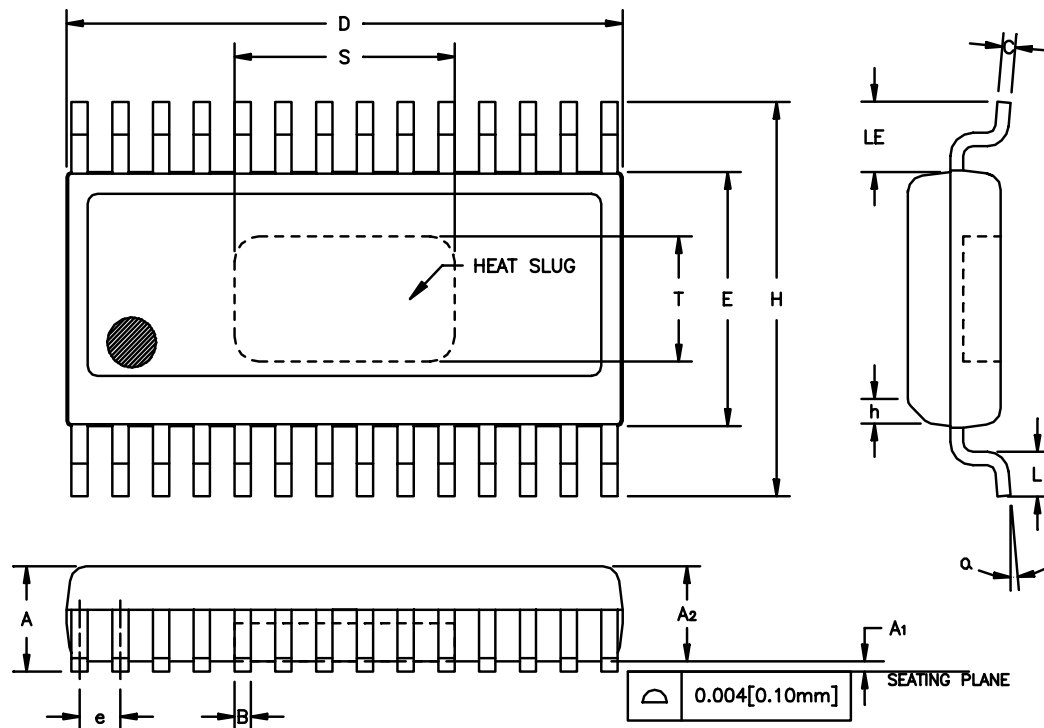

Figure 14: Solder Mask Outline

ARA05050

PACKAGE OUTLINE



Symbol	INCHES		MILLIMETERS		NOTE
	MIN.	MAX.	MIN.	MAX.	
A	0.058	0.068	1.47	1.73	
A1	0.000	0.004	0.00	0.10	
A2	0.054	0.060	1.37	1.52	
B	0.008	0.014	0.20	0.35	5
C	0.007	0.012	0.18	0.30	5
D	0.385	0.393	9.78	9.98	2
E	0.151	0.157	3.84	3.99	3
e	0.025 BSC		0.64 BSC		4
H	0.228	0.244	5.79	6.20	
h	0.015x45°		0.38x45°		
L	0.016	0.032	0.41	0.81	
LE	0.042	—	1.07	—	
alpha	0°	8°	0°	8°	
S	0.105	0.135	2.67	3.43	6
T	0.045	0.075	1.41	1.91	6

NOTES:

1. CONTROLLING DIMENSION: INCHES
2. DIMENSION "D" DOES NOT INCLUDE MOLD FLASH, PROTRUSIONS OR GATE BURRS. MOLD FLASH, PROTRUSIONS AND GATE BURRS SHALL NOT EXCEED 0.006 [0.15mm] PER SIDE.
3. DIMENSION "E" DOES NOT INCLUDE INTER-LEAD FLASH OR PROTRUSIONS. INTER-LEAD FLASH AND PROTRUSIONS SHALL NOT EXCEED 0.010 [0.25mm] PER SIDE.
4. MAXIMUM LEAD TWIST/SKEW TO BE ±0.0035 [0.089mm].
5. LEAD WIDTH "B" AND THICKNESS "c" MAX. DIMENSION IS AFTER PLATING.
6. DIMENSIONS "S" AND "T" INDICATE EXPOSED SLUG AREA.

Figure 15: S12 Package Outline - 28 Pin SSOP with Heat Slug

COMPONENT PACKAGING

Volume quantities of the ARA05050 are supplied on tape and reel. Each reel holds 3,500 pieces. Smaller quantities are available in plastic tubes of 50 pieces.

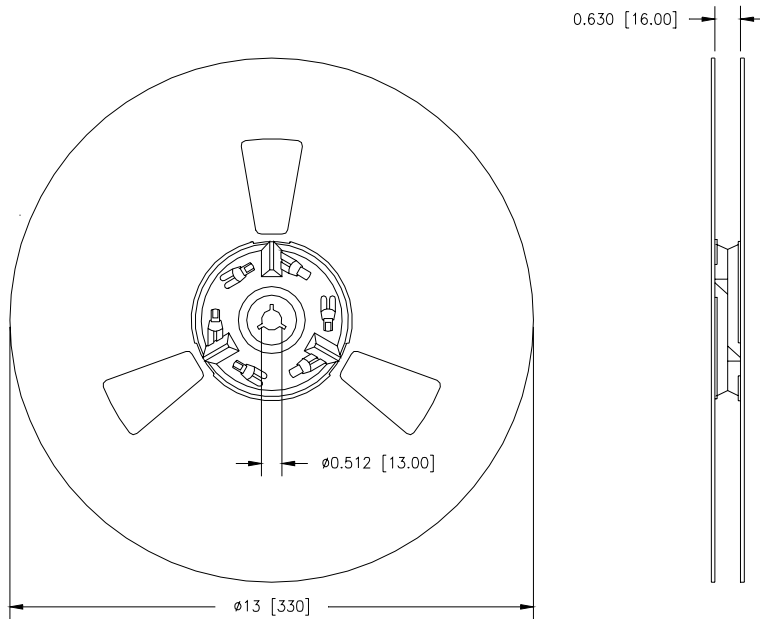

Figure 16: Reel Dimensions

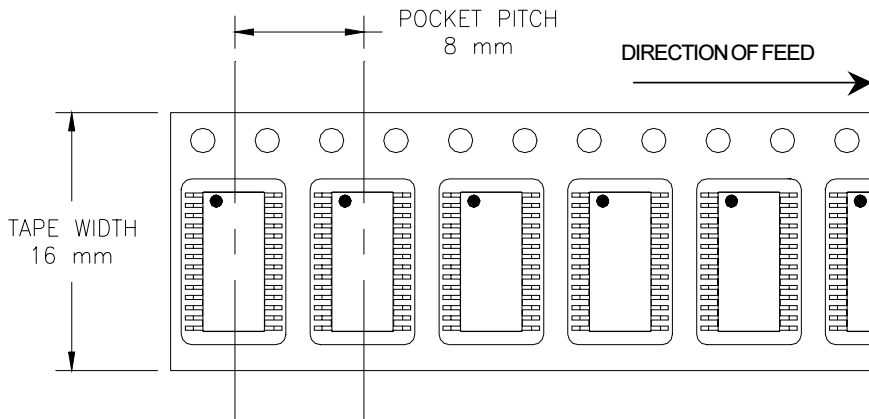

Figure 17: Tape Dimensions

ARA05050

NOTES

NOTES

ARA05050

ORDERING INFORMATION

ORDER NUMBER	TEMPERATURE RANGE	PACKAGE DESCRIPTION	COMPONENT PACKAGING
ARA05050S12CTR	-40 to 85 °C	28 Pin SSOP with Heat Slug	3,500 piece tape and reel
ARA05050S12C	-40 to 85 °C	28 Pin SSOP with Heat Slug	Plastic tubes (50 pieces per tube)



ANADIGICS, Inc.

141 Mount Bethel Road

Warren, New Jersey 07059, U.S.A.

Tel: +1 (908) 668-5000

Fax: +1 (908) 668-5132

URL: <http://www.anadigics.com>

E-mail: Mktg@anadigics.com

IMPORTANT NOTICE

ANADIGICS, Inc. reserves the right to make changes to its products or to discontinue any product at any time without notice. The product specifications contained in Advanced Product Information sheets and Preliminary Data Sheets are subject to change prior to a product's formal introduction. Information in Data Sheets have been carefully checked and are assumed to be reliable; however, ANADIGICS assumes no responsibilities for inaccuracies. ANADIGICS strongly urges customers to verify that the information they are using is current before placing orders.

WARNING

ANADIGICS products are not intended for use in life support appliances, devices or systems. Use of an ANADIGICS product in any such application without written consent is prohibited.