



ARA1400/ARA1400I

Reverse Amplifier with Step Attenuator Data Sheet - Rev 2.0

FEATURES

- Low cost integrated monolithic GaAs amplifier with step attenuator
- Attenuation Range: 0-56 dB, adjustable in 4dB increments via a 4 wire parallel control
- Meets DOCSIS distortion requirements at +60dBmV output signal level
- Low distortion and low noise
- Frequency range: 5-100MHz
- 5 Volt operation
- -40 to +85 °C or 0 to +85 °C temperature range options available

APPLICATIONS

- MCNS/DOCSIS Compliant Cable Modems
- CATV Interactive Set-Top Box
- Telephone over Cable Systems
- OpenCable Set-Top Box
- Residential Gateway



PRODUCT DESCRIPTION

The ARA1400 and the ARA1400I are GaAs ICs designed to provide the reverse path amplification and output level control functions in a CATV Set-Top Box or Cable Modem. Each incorporates a digitally controlled precision step attenuator that is preceded by an ultra low noise amplifier stage, and followed by an ultra-linear output driver amplifier. These devices are capable of meeting the MCNS/DOCSIS requirements for harmonic performance at a +60dBmV output level while requiring only a single

polarity +5V supply. On each device, both the input and the output are single-ended and matched to 75 Ohms, and a precision attenuator provides up to 56 dB of attenuation in 4 dB increments. Both devices are offered in a 28-pin SSOP package featuring a heat slug on the bottom of the package. Two temperature range options are available: the ARA1400 for commercial applications, and the ARA1400I for industrial applications.

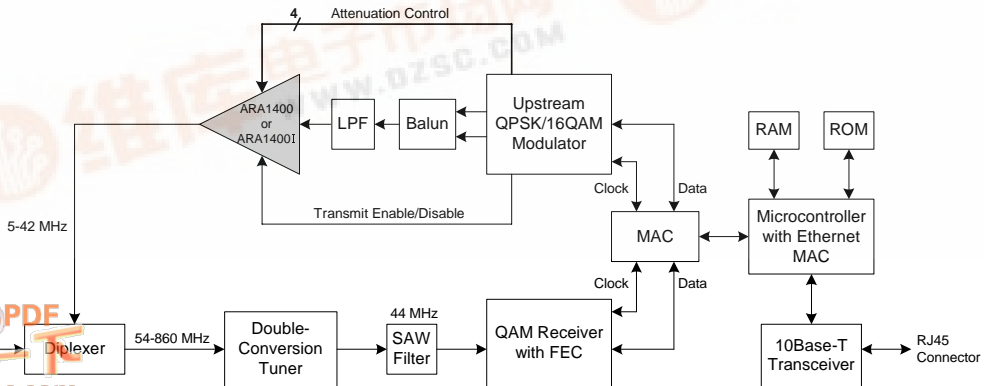
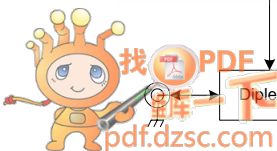

Figure 1. Cable Modem or Set Top Box Application Diagram



ARA1400/ARA1400I

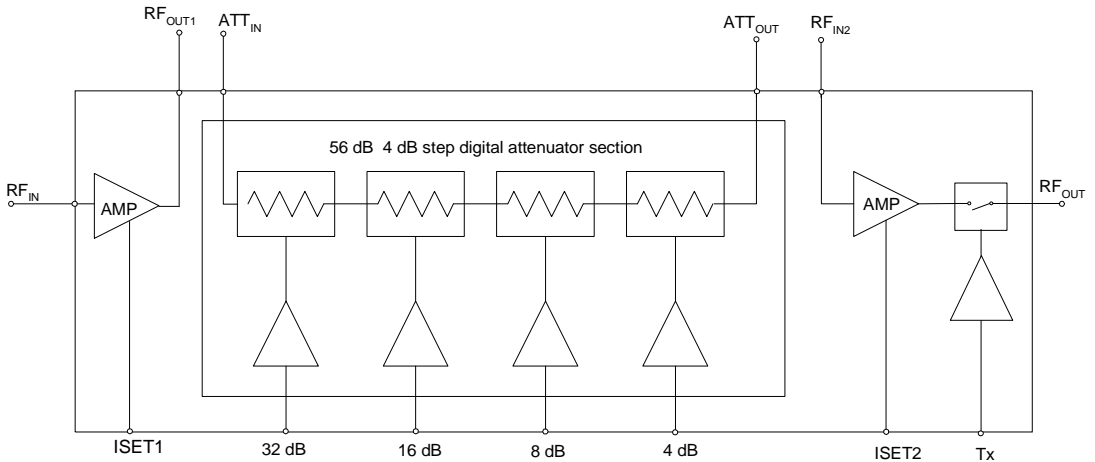

Figure 2: Functional Block Diagram

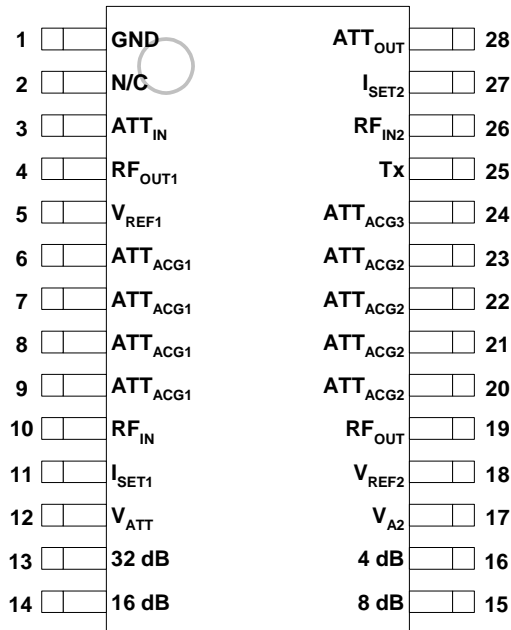

Figure 3: Pin Out

Table 1: Pin Description

PIN	NAME	DESCRIPTION	PIN	NAME	DESCRIPTION
1	GND	Ground	15	8 dB	82 dB Attenuation Control Bit
2	N/C	No Connection ⁽¹⁾	16	4 dB	4 dB Attenuation Control Bit
3	ATT _{IN}	Attenuator Input ⁽²⁾	17	V _{A2}	Amplifier A2 Supply
4	RF _{OUT1}	Amplifier A1 Output and Supply	18	V _{REF2}	Reference Voltage for Amplifier A2
5	V _{REF1}	Reference Voltage for Amplifier A1	19	RF _{OUT}	RF Output from Switch ⁽²⁾
6	ATT _{ACG1}	Attenuator AC Ground 1 ⁽³⁾	20	ATT _{ACG2}	Attenuator AC Ground 2 ⁽³⁾
7	ATT _{ACG1}	Attenuator AC Ground 1 ⁽³⁾	21	ATT _{ACG2}	Attenuator AC Ground 2 ⁽³⁾
8	ATT _{ACG1}	Attenuator AC Ground 1 ⁽³⁾	22	ATT _{ACG2}	Attenuator AC Ground 2 ⁽³⁾
9	ATT _{ACG1}	Attenuator AC Ground 1 ⁽³⁾	23	ATT _{ACG2}	Attenuator AC Ground 2 ⁽³⁾
10	RF _{IN}	Amplifier A1 Input ⁽⁴⁾	24	ATT _{ACG3}	Attenuator AC Ground 3 ⁽³⁾
11	I _{SET1}	Amplifier A1 Current Adjust	25	Tx	Output Switch Control
12	V _{ATT}	Attenuator Supply	26	RF _{IN2}	Amplifier A2 Input ⁽⁴⁾
13	32 dB	32 dB Attenuation Control Bit	27	I _{SET2}	Amplifier A2 Current Adjust
14	16 dB	16 dB Attenuation Control Bit	28	ATT _{OUT}	Attenuator Output ⁽²⁾

Notes:

(1) All N/C pins should be grounded.

(2) Pins should be AC-coupled. No external DC bias should be applied.

(3) Pins should be AC-grounded. No external DC bias should be applied.

(4) Pins should be AC-coupled from the RF path, and should be pulled to ground through a resistor.

ELECTRICAL CHARACTERISTICS

Table 2: Absolute Minimum and Maximum Ratings

PARAMETER	MIN	MAX	UNIT
Analog Supply: V_{SUP} (pins 4, 12, 17)	0	9	VDC
Amplifier Reference Voltages (pins 5, 18)	-2.5	$\frac{V_{SUP}}{2}$	VDC
RF Power at Amplifier Inputs (pins 10, 26)	-	+60	dBmV
Attenuator Controls (pins 13, 14, 15, 16)	0	6	V
Output Switch Control (pin 25)	0	6	V
Storage Temperature	-55	+200	°C
Soldering Temperature	-	260	°C
Soldering Time	-	5	Sec

Stresses in excess of the absolute ratings may cause permanent damage. Functional operation is not implied under these conditions. Exposure to absolute ratings for extended periods of time may adversely affect reliability.

Notes:

1. Pins 3, 19, and 28 should be AC-coupled. No external DC bias should be applied.
2. Pins 11 and 27 should be grounded or pulled to ground through a resistor. No external DC bias should be applied.
3. Pins 6, 7, 8, 9, 20, 21, 22, 23 and 24 should be AC-grounded. No external DC bias should be applied.
4. Pins 10 and 26 should be AC-coupled from the RF path, and should be pulled to ground through a resistor.

Table 3: Operating Ranges

PARAMETER	MIN	TYP	MAX	UNIT
Amplifier Supply: V_{DD} (pins 4, 17)	4.5	5	7	VDC
Attenuator Supply: V_{ATTN} (pin 12)	$V_{DD}-0.5$	5	7	VDC
Attenuator Controls (pins 13, 14, 15, 16)	0	-	5.5	V
Amplifier Reference Voltages (pins 5, 18)	-	1.75	-	VDC
Output Switch Control (pin 25)	0	-	5.5	V
Case Temperature - ARA1400 - ARA1400I	0 -40	25 25	85 85	°C

The device may be operated safely over these conditions; however, parametric performance is guaranteed only over the conditions defined in the electrical specifications.

Table 4: DC Electrical Specifications
 $T_A=25^{\circ}\text{C}$; $V_{DD}, V_{ATTN} = +5.0\text{ VDC}$

PARAMETER	MIN	TYP	MAX	UNIT	COMMENTS
Amplifier A1 Current (pin 4)	- 70	74 81.4	95 95	mA	ARA1400 ARA1400I
Amplifier A2 Current (pin 17)	- 105	108 121	130 130	mA	ARA1400 ARA1400I
Attenuator Current (pin 12)	- 12	12 14	20 20	mA	ARA1400 ARA1400I
Total Power Consumption	- 0.94	0.97 1.08	1.23 1.23	W W	ARA1400 ARA1400I

Table 5: AC Electrical Specifications
 $T_A=25^{\circ}\text{C}$; $V_{DD}, V_{ATTN} = +5.0\text{ VDC}$; $T_x = 0\text{ V}$ (switch closed), $T_x = +5\text{ V}$ (switch open)

PARAMETER	MIN	TYP	MAX	UNIT	COMMENTS
Gain (10 MHz)	30	32	33	dB	0 dB attenuation setting
Gain Flatness	-	0.75	-	dB	5 to 100 MHz
Gain Variation over Temperature	-	-0.006	-	dB/ $^{\circ}\text{C}$	
Attenuation Steps					
4 dB	3.6	3.9	4.2	dB	Monotonic
8 dB	7.7	8.0	8.3		
16 dB	15.3	15.7	16.1		
32 dB	31.0	31.5	32.0		
Switch Isolation at 45 MHz	-	35	30	dB	Difference in output signal level between active and standby
2 nd Harmonic Distortion Level (10 MHz)	-	-57	-52	dBc	+60 dBmV into 75 Ohms
3 rd Harmonic Distortion Level (10 MHz)	-	-64	-56	dBc	+60 dBmV into 75 Ohms
3 rd Order Output Intercept	78	-	-	dBmV	
1 dB Gain Compression Point	-	70	-	dBmV	
Noise Figure	-	1.7	2.5	dB	

Note: As measured in ANADIGICS test fixture

continued: AC Electrical Specifications

T_A=25°C; V_{DD}, V_{ATTN} = +5.0 VDC; T_x = 0 V (switch closed), T_x = +5 V (switch open)

PARAMETER	MIN	TYP	MAX	UNIT	COMMENTS
Output Noise Power Active / No Signal / Min. Atten. Set. Active / No Signal / Max. Atten. Set.	- -	- -	-37.6 -54.6	dBmV	Any 160 kHz bandwidth from 5 to 42 MHz
Input Impedance	-	75	-	Ohms	
Input Return Loss (75 Ohm characteristic impedance)	-	-20	-15	dB	
Output Impedance	-	-20 -12	-15 -10	Ohms	Switch closed Switch open
Output Return Loss (75 Ohm characteristic impedance)	- -	-17 -15	-12 -10	dB	Switch closed Switch open
Output Voltage Transient switch closed / switch open	-	4	7	mVp-p	

Note: As measured in ANADIGICS test fixture

Table 6: Logic Interface Specifications

T_A=25°C; V_{DD}, V_{ATTN} = +5.0 VDC

PARAMETER	MIN	TYP	MAX	UNIT	COMMENTS
Attenuator Control Logic V _{IN,LOW} V _{IN,HIGH}	0 2.7	- -	0.5 5.5	V	Bypasses atten. stage Enables atten. stage
Attenuator Control Impedance	-	5K	-	Ohms	
Output Switch Control Logic V _{IN,LOW} V _{IN,HIGH}	0 2.8	- -	1 5.5	V	Switch closed Switch open
Output Switch Control Impedance	-	10K	-	Ohms	

Table 7: Attenuator Logic

ATTENUATION (dB)	0	4	8	12	16	20	24	28	32	36	40	44	48	52	56	60
4 dB Logic Input (pin 16)	L	H	L	H	L	H	L	H	L	H	L	H	L	H	L	H
8 dB Logic Input (pin 15)	L	L	H	H	L	L	H	H	L	L	H	H	L	L	H	H
16 dB Logic Input (pin 14)	L	L	L	L	H	H	H	H	L	L	L	L	H	H	H	H
32 dB Logic Input (pin 13)	L	L	L	L	L	L	L	L	H	H	H	H	H	H	H	H

Note: "L" = logic low "H" = logic high

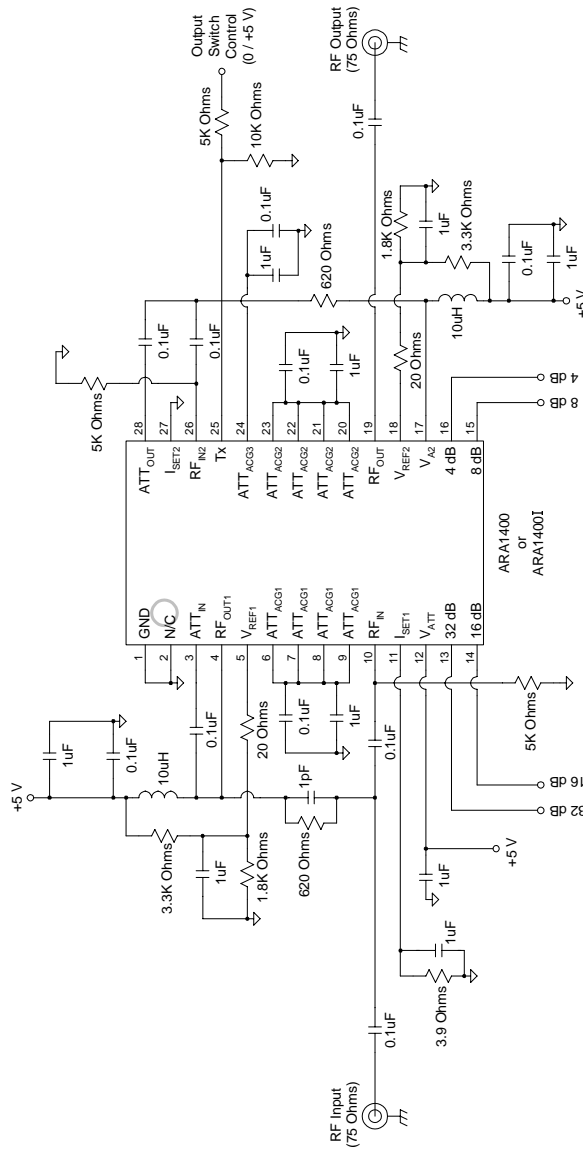

Note:
 Output Switch Closed: Output Switch Control = 0 V
 Output Switch Open: Output Switch Control = +5 V

Figure 4: Test Circuit

ARA1400/ARA1400I

APPLICATION INFORMATION

Amplifier Enable / Disable

The ARA1400 and the ARA1400I include two amplification stages that each can be shut down through external control pins V_{REF1} and V_{REF2} (pins 5 and 18, respectively.) By applying a typical bias of 1.75 Volts to these pins, the amplifiers are enabled. In order to fully disable an amplifier, its control pin requires a negative bias of -1.5 to -2.0 Volts.

Output Switch Control

A switch located at the output of Amplifier A2 in the ARA1400 and the ARA1400I provides isolation without having to disable the amplifiers. The switch is controlled by the Tx logic input (pin 25.)

Amplifier Bias Current

The I_{SET} pins (11 and 27) set the bias current for the amplification stages. Grounding these pins results in the maximum possible current. By placing a resistor from the pin to ground, the current can be reduced. The recommended bias conditions use the configuration shown in the test circuit schematic in Figure 4.

Thermal Layout Considerations

The device package for the ARA1400 and the ARA1400I features a heat slug on the bottom of the package body. Use of the heat slug is an integral part of the device design. Soldering it to the ground plane of the PC board will ensure the lowest possible thermal resistance for the device, and will result in the longest MTF (mean time to failure.)

A PC board layout that optimizes the benefits of the heat slug is shown in Figure 5. The via holes located under the body of the device must be plated through to a ground plane layer of metal, in order to provide sufficient thermal conductivity. The recommended solder mask outline is shown in Figure 6.

ESD Sensitivity

Electrostatic discharges can cause permanent damage to these devices. Electrostatic charges accumulate on test equipment and the human body, and can discharge without detection. Proper precautions and handling are strongly recommended. Refer to the ANADIGICS application note on ESD precautions.

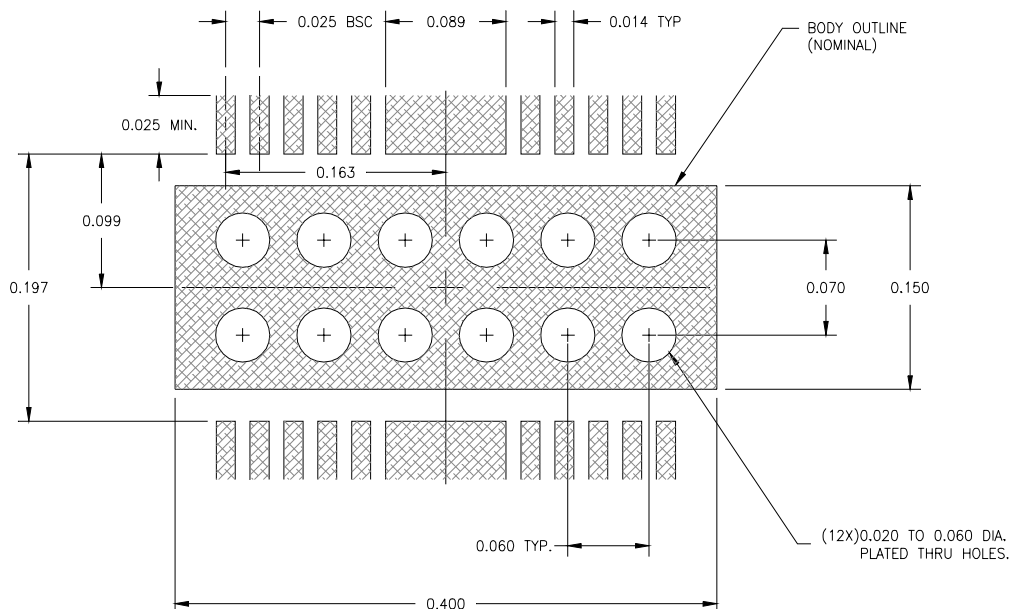

Figure 5: PC Board Layout

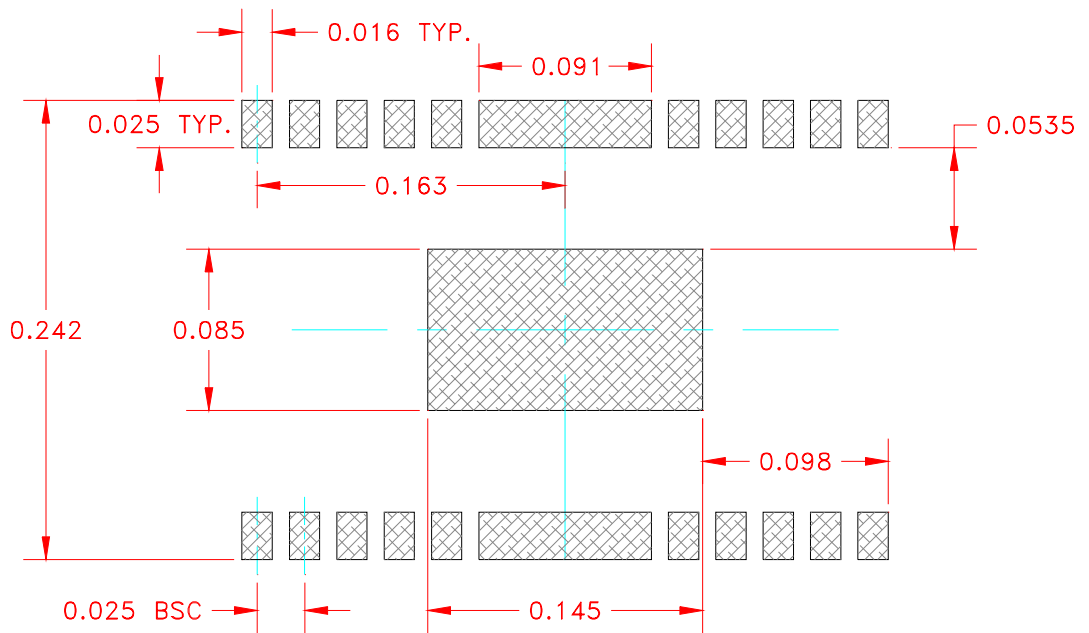
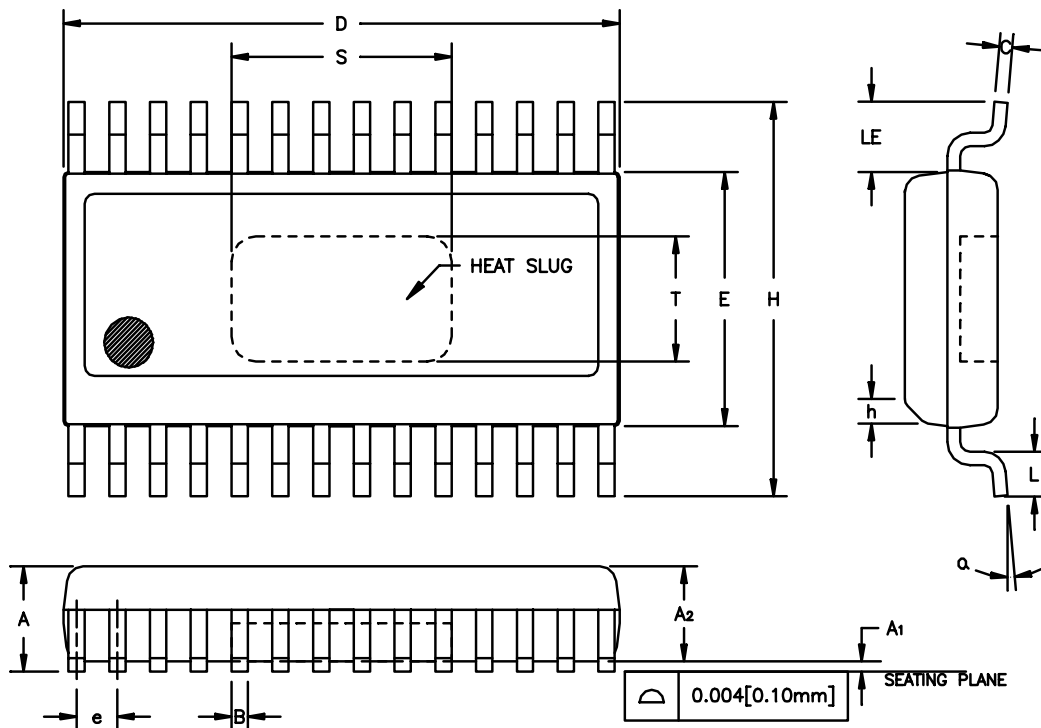

Figure 6: Solder Mask Outline

ARA1400/ARA1400I
 PACKAGE OUTLINE



Symbol	INCHES		MILLIMETERS		NOTE
	MIN.	MAX.	MIN.	MAX.	
A	0.058	0.068	1.47	1.73	
A ₁	0.000	0.004	0.00	0.10	
A ₂	0.054	0.060	1.37	1.52	
B	0.008	0.014	0.20	0.35	5
C	0.007	0.012	0.18	0.30	5
D	0.385	0.393	9.78	9.98	2
E	0.151	0.157	3.84	3.99	3
e	0.025 BSC		0.64 BSC		4
H	0.228	0.244	5.79	6.20	
h	0.015x45°		0.38x45°		
L	0.016	0.032	0.41	0.81	
LE	0.042	—	1.07	—	
α	0°	8°	0°	8°	
S	0.105	0.135	2.67	3.43	6
T	0.045	0.075	1.41	1.91	6

NOTES:

1. CONTROLLING DIMENSION: INCHES
2. DIMENSION "D" DOES NOT INCLUDE MOLD FLASH, PROTRUSIONS OR GATE BURRS. MOLD FLASH, PROTRUSIONS AND GATE BURRS SHALL NOT EXCEED 0.006 [0.15mm] PER SIDE.
3. DIMENSION "E" DOES NOT INCLUDE INTER-LEAD FLASH OR PROTRUSIONS. INTER-LEAD FLASH AND PROTRUSIONS SHALL NOT EXCEED 0.010 [0.25mm] PER SIDE.
4. MAXIMUM LEAD TWIST/SKEW TO BE ±0.0035 [0.089mm].
5. LEAD WIDTH "B" AND THICKNESS "c" MAX. DIMENSION IS AFTER PLATING.
6. DIMENSIONS "S" AND "T" INDICATE EXPOSED SLUG AREA.

Figure 7: S12 Package Outline - 28 Pin SSOP with Heat Slug

COMPONENT PACKAGING

Volume quantities of the ARA1400 and the ARA1400I are supplied on tape and reel. Each reel holds 3,500 pieces. Smaller quantities are available in plastic tubes of 50 pieces.

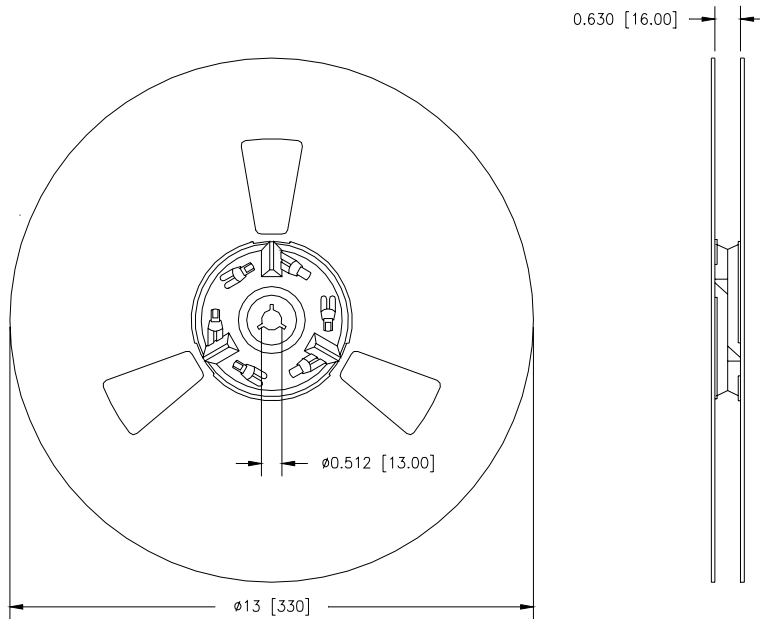

Figure 8: Reel Dimensions

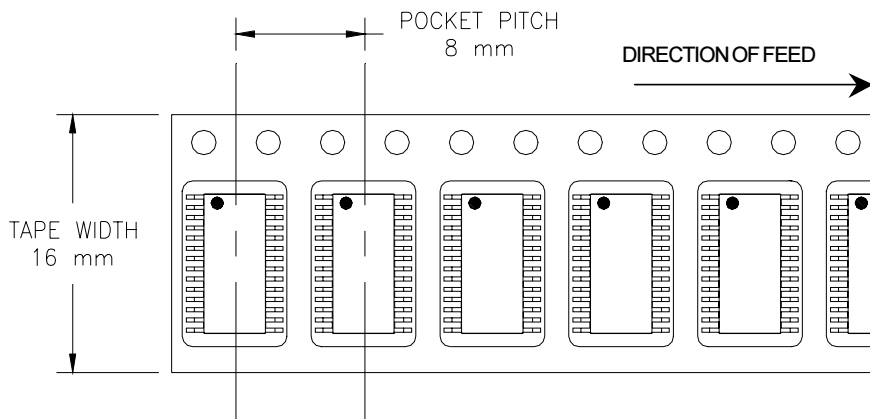

Figure 9: Tape Dimensions

ARA1400/ARA1400I

ORDERING INFORMATION

ORDER NUMBER	TEMPERATURE RANGE	PACKAGE DESCRIPTION	COMPONENT PACKAGING
ARA1400S12CTR	0 to 85 °C	28 Pin SSOP with Heat Slug	3,500 piece tape and reel
ARA1400S12C	0 to 85 °C	28 Pin SSOP with Heat Slug	Plastic tubes (50 pieces per tube)
ARA1400IS12CTR	-40 to 85 °C	28 Pin SSOP with Heat Slug	3,500 piece tape and reel
ARA1400IS12C	-40 to 85 °C	28 Pin SSOP with Heat Slug	Plastic tubes (50 pieces per tube)



ANADIGICS, Inc.

141 Mount Bethel Road

Warren, New Jersey 07059, U.S.A.

Tel: +1 (908) 668-5000

Fax: +1 (908) 668-5132

URL: <http://www.anadigics.com>

E-mail: Mktg@anadigics.com

IMPORTANT NOTICE

ANADIGICS, Inc. reserves the right to make changes to its products or to discontinue any product at any time without notice. The product specifications contained in Advanced Product Information sheets and Preliminary Data Sheets are subject to change prior to a product's formal introduction. Information in Data Sheets have been carefully checked and are assumed to be reliable; however, ANADIGICS assumes no responsibilities for inaccuracies. ANADIGICS strongly urges customers to verify that the information they are using is current before placing orders.

WARNING

ANADIGICS products are not intended for use in life support appliances, devices or systems. Use of an ANADIGICS product in any such application without written consent is prohibited.