



ACD0900

VHF/UHF CATV/TV Tuner
Downconverter
Data Sheet - Rev 2.1

FEATURES

- Integrated Monolithic Downconverter
- 8 dB Noise Figure
- 10 dB Conversion Gain
- High Linearity
- Small Size
- Low Cost
- High Reliability



PRODUCT DESCRIPTION

The ACD0900 MMIC is a high performance downconverter fabricated entirely in GaAs. It is designed for use as the second conversion stage in double-conversion tuners and cable modems, downconverting 900 -1200 MHz RF inputs to a fixed IF of 35 - 150 MHz (depending on LO frequency).

The IC incorporates a low noise amplifier, high linearity double balanced mixer, phase splitter and oscillator in a modified SOIC 16 lead surface mount package. The high degree of functionality allows tuner manufacturers to reduce size and cost by lowering the component count and decreasing the amount of production alignment steps, while significantly improving performance and reliability.

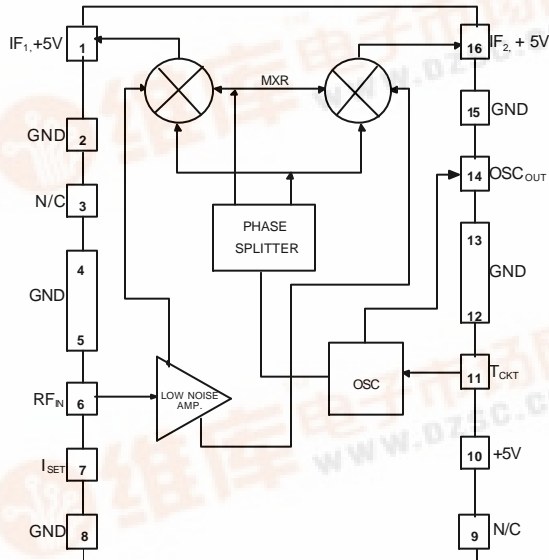

Figure 1: Functional Block Diagram



ACD0900**Table 1: Pin Description**

PIN	DESCRIPTION	PIN	DESCRIPTION
1	IF_1, V_{DDIF}	9	NC*
2	GND	10	V_{DDLO}
3	NC	11	T_{CKT}
4	GND	12	GND
5	GND	13	GND
6	RF_N	14	OSC OUT
7	I_{SET}	15	GND
8	GND	16	IF_2, V_{DDIF}

* Do not connect pin 9 to GND

ELECTRICAL CHARACTERISTICS

Table 2: Absolute Minimum and Maximum Ratings

PARAMETER	MIN	MAX	UNIT
V_{DDIF} , V_{DDLO} , V_{OSC}	-	9	Volts
V_{RF} , $V_{TCKT}^{(1)}$	-	0	Volts
Storage Temperature	- 55	200	°C
Soldering Temperature	-	260	°C
Soldering Time	-	5	Sec.
RF Input Power	-	+ 10	dBm
LO Input Power	-	+ 17	dBm
Thermal Resistance	-	25	°C/W

Stresses in excess of the absolute ratings may cause permanent damage. Functional operation is not implied under these conditions. Exposure to absolute ratings for extended periods of time may adversely affect reliability.

Note:

(1) V_{TCKT} : Maximum voltage that may be applied to pin 11 of the device without damaging the IC. DC blocking capacitor (1500 pF) between pin 11 and the external tuning circuit is mandatory.

Table 3: Operating Ranges

PARAMETER	MIN	TYP	MAX	UNIT
Frequency				
RF	900	-	1200	MHz
LO	935	-	1350	
IF	35	-	150	
V_{DDIF} , V_{DDLO}	4.75	5.0	5.25	VDC
Case Temperature	- 55	-	85	°C

The device may be operated safely over these conditions; however, parametric performance is guaranteed only over the conditions defined in the electrical specifications.

ACD0900

Table 4: Electrical Specifications
 (T_A = +25°C; V_{DDIF}, V_{DDLO} = +5V)

PARAMETER	MIN	TYP	MAX	UNIT	COMMENTS
Frequencies					
RF	-	1170	-	MHz	
LO	-	1245	-		
IF	-	75	-		
Phase Noise @ 10 KHz Offset	-	- 89	- 85.5	dBc/Hz	
Noise Figure	-	8.0	9.5	dB	
Gain (200Ω Load) ⁽¹⁾	7.8	9.5	-	dB	
3rd Order IMD (200Ω Load) ⁽²⁾	-	- 59	- 54	dBc	
3rd Order Input IP (200Ω Load) ⁽²⁾	+ 12	-	-	dBm	
Cross Modulation @ 15 KHz, ⁽²⁾ 99% AM Modulation	-	- 56	-	dBc	
Current Consumption	-	80	110	mA	
Power Consumption @ 5.0V	-	400	-	mW	

Notes:

(1) Combined output (IF₁ + IF₂) using a balun. NOTE: Gain at either port (uncombined), with unused port terminated in 50 Ω, is 3 dB lower

(2) Two tones @ -15 dBm per tone

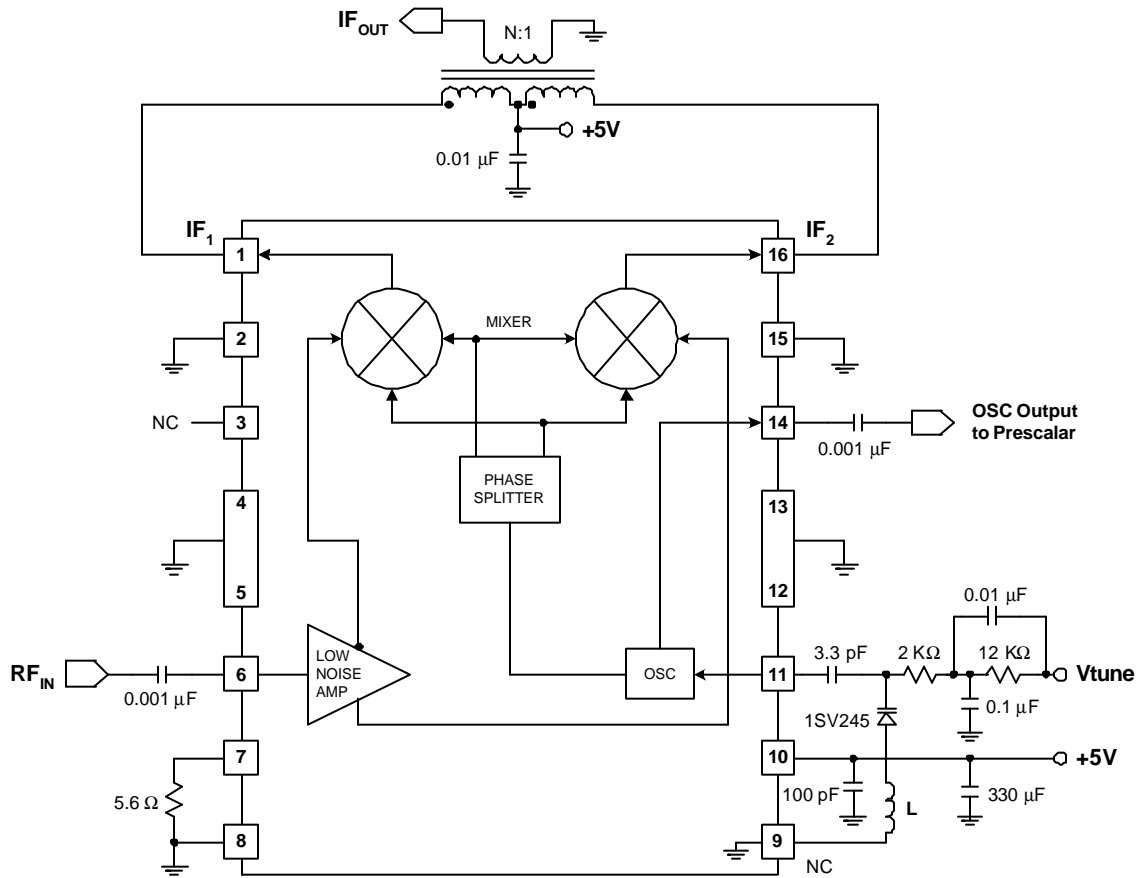

Figure 2: Test Circuit Schematic

ACD0900

PERFORMANCE DATA

Figure 3: RF Input Impedance

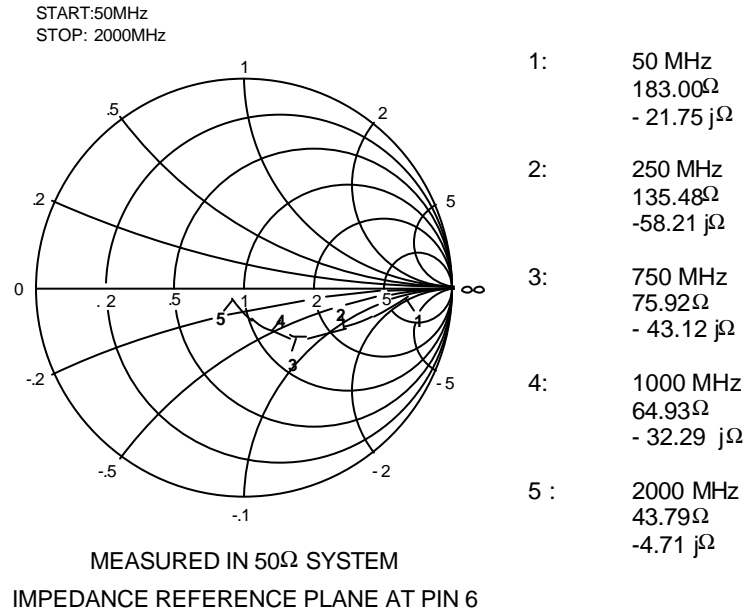

Figure 4: IF Output Impedance

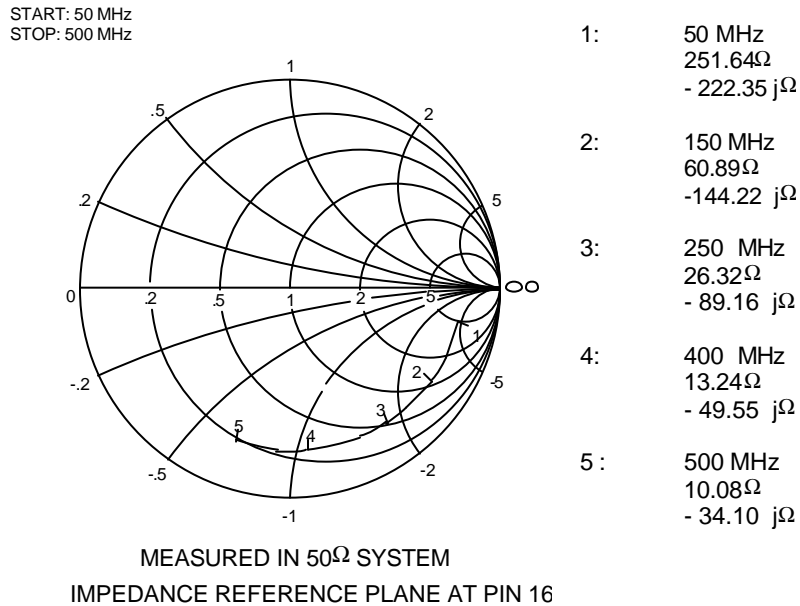
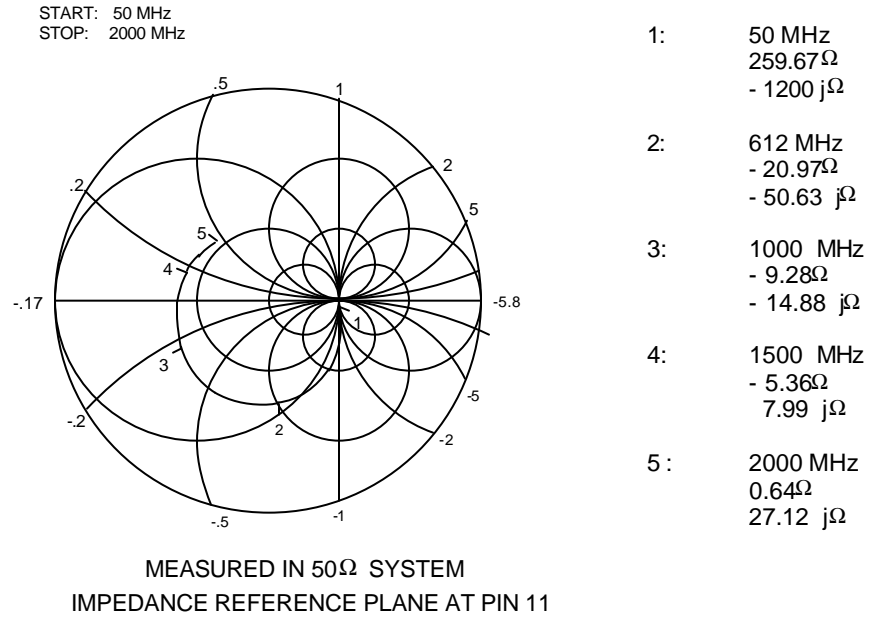
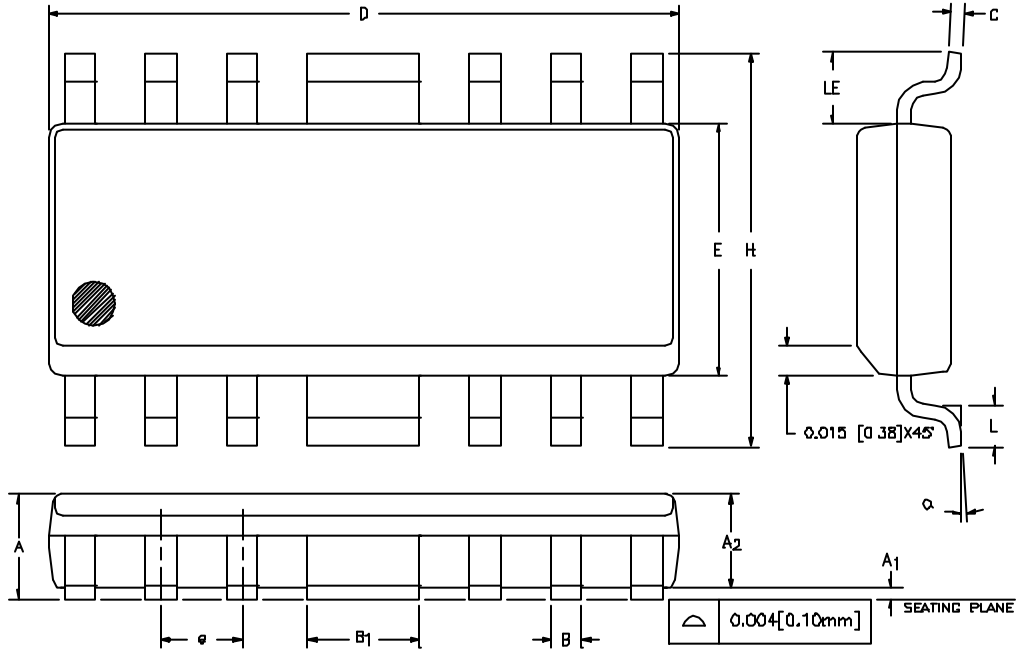

Figure 5: LO Impedance



ACD0900

PACKAGE OUTLINE



SYMBOL	INCHES		MILLIMETERS		NOTE
	MIN.	MAX.	MIN.	MAX.	
A	0.058	0.068	1.47	1.73	
A1	0.004	0.010	0.10	0.25	
A2	0.055	0.065	1.40	1.65	
B	0.013	0.020	0.33	0.50	
B1	0.062	0.070	1.58	1.78	
C	0.008	0.010	0.20	0.25	4
D	0.380	0.400	9.66	10.16	2
E	0.150	0.160	3.81	4.06	3
e	0.050 BSC		1.27 BSC		
H	0.226	0.244	5.74	6.20	
L	0.016	0.040	0.41	1.02	
LE	0.030	—	0.76	—	
α	D'	B'	D'	B'	

NOTES:

1. CONTROLLING DIMENSION: INCHES
2. DIMENSION "D" DOES NOT INCLUDE MOLD FLASH, PROTRUSIONS OR GATE BURRS. MOLD FLASH, PROTRUSIONS AND GATE BURRS SHALL NOT EXCEED 0.006 [0.15mm] PER SIDE.
3. DIMENSION "E" DOES NOT INCLUDE INTER-LEAD FLASH OR PROTRUSIONS. INTER-LEAD FLASH AND PROTRUSIONS SHALL NOT EXCEED 0.010 [0.25mm] PER SIDE.
4. MAXIMUM LEAD TWIST/SKEW TO BE ±0.005 [0.13mm].
5. LEAD THICKNESS AFTER PLATING TO BE 0.013 [0.33mm] MAXIMUM.

Figure 6: S3 Package Outline - Modified 16 Pin SOIC

ACD0900

NOTES

ACD0900

NOTES

NOTES

ACD0900

ORDERING INFORMATION

ORDER NUMBER	TEMPERATURE RANGE	PACKAGE DESCRIPTION	COMPONENT PACKAGING
ACD0900S3CTR	-55°C to +85°C	Modified 16 Pin SOIC	Tape & Reel, 3500 pieces per reel
ACD0900S3C	-55°C to +85°C	Modified 16 Pin SOIC	Tube, 50 pieces per tube



ANADIGICS, Inc.

141 Mount Bethel Road
Warren, New Jersey 07059, U.S.A.
Tel: +1 (908) 668-5000
Fax: +1 (908) 668-5132

URL: <http://www.anadigics.com>
E-mail: Mktg@anadigics.com

IMPORTANT NOTICE

ANADIGICS, Inc. reserves the right to make changes to its products or to discontinue any product at any time without notice. The product specifications contained in Advanced Product Information sheets and Preliminary Data Sheets are subject to change prior to a product's formal introduction. Information in Data Sheets have been carefully checked and are assumed to be reliable; however, ANADIGICS assumes no responsibilities for inaccuracies. ANADIGICS strongly urges customers to verify that the information they are using is current before placing orders.

WARNING

ANADIGICS products are not intended for use in life support appliances, devices or systems. Use of an ANADIGICS product in any such application without written consent is prohibited.