



# AMT8304

2.125 Gb/s Integrated 850nm MSM-TIA  
PRELIMINARY DATA SHEET - Rev 1.1

## FEATURES

- Differential Output TIA
- 3.3V Operation
- Automatic Gain Control
- Integrated 850nm MSM Detector & TIA
- TO-46 Ultra Flat-Window or Lens Hermetic Package
- High Reliability

## APPLICATIONS

- 2x Fibre Channel (2.125 Gb/s)

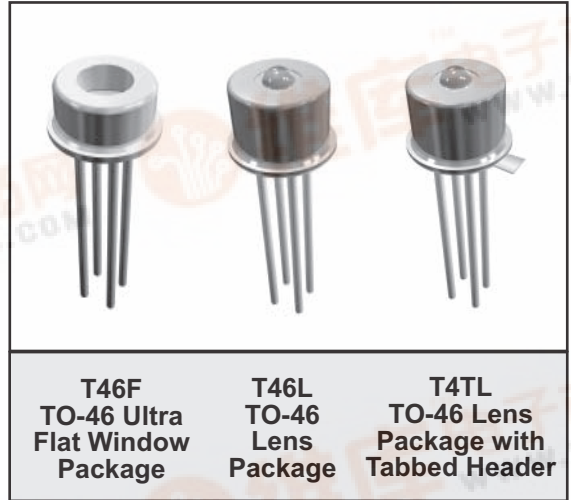

## PRODUCT DESCRIPTION

The ANADIGICS AMT8304 is a 3.3V monolithically integrated Metal-Semiconductor-Metal (MSM) photodetector and transimpedance amplifier (TIA) used to convert an 850nm input optical signal into a differential output voltage, and is manufactured in ANADIGICS' 6" GaAs wafer fabrication facility. The integrated MSM and TIA receiver maximizes the receiver performance by minimizing the photodetector input parasitics to the TIA and

internally biasing the photodetector to achieve high sensitivity, bandwidth and overload performance. As an integrated product the reliability is inherently better than a discrete solution, and both the MSM-TIA integrated circuit and TO-46 flat window and TO-46 lens packaged receiver pass stringent reliability requirements. These products are readily designed into receivers and transceivers for 2x Fibre Channel applications.

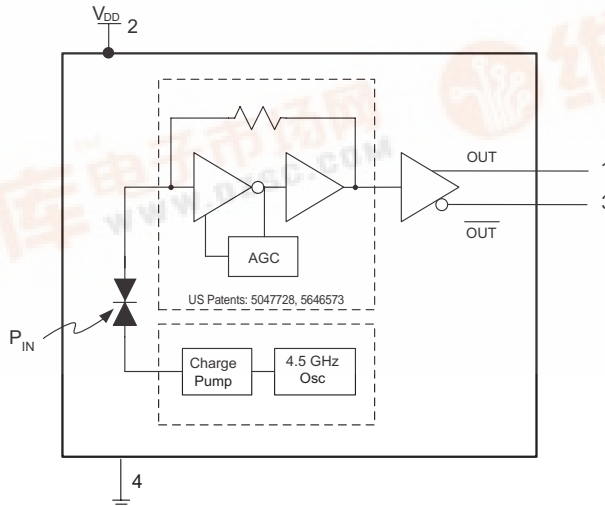

Figure 1: Equivalent Circuit



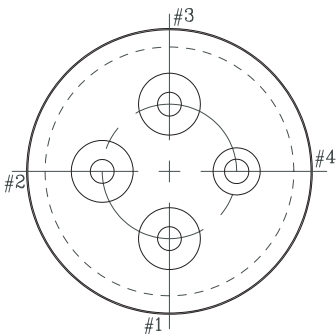

Figure 2: T46F/T46L/T4TL Pin Outline (Bottom View)

Table 1: Package PIN Description

PIN	DESCRIPTION	COMMENT
1	$V_{OUT}$ - TIA Output Voltage (non-Inverted)	Logical '1' with optical input
2	$V_{DD}$ - Positive Supply Voltage	+3.3 Volts
3	$\overline{V_{OUT}}$ - TIA Output Voltage (Inverted)	Logical '0' with optical input
4	Ground	Case is grounded

**ELECTRICAL CHARACTERISTICS**

Table 2: Absolute Maximum Ratings

$V_{DD}$	6.0V
$P_{IN}$	+5dBm
$T_S$	Storage Temp. -65 °C to 125 °C

**Stresses in excess of the absolute ratings may cause permanent damage. Functional operation is not implied under these conditions. Exposure to absolute ratings for extended periods of time may adversely affect reliability.**

Table 3: Electrical Characteristics

PARAMETER	MIN	TYP	MAX	UNIT
Wavelength ( $\lambda$ )	770	850	860	nm
Detector Diameter	-	100	-	$\mu\text{m}$
Small Signal Differential Responsivity <sup>(1)</sup> (@ 50 MHz)	1000	-	-	V/W
Bandwidth <sup>(1)</sup>	1400	1900	-	MHz
Low Frequency Cutoff	-	-	300	KHz
Output Resistance	-	40	-	
Optical Overload <sup>(2)</sup>	0	-	-	dBm
Optical Sensitivity <sup>(2)</sup>	-19	-	-	dBm
Differential Output Voltage <sup>(3)</sup>	-	750	-	mV
T <sub>RISE</sub> and T <sub>FALL</sub> (20-80%) <sup>(3)</sup>	-	140	-	ps
Duty Cycle Distortion <sup>(3)</sup>	-	5	-	%
Total Jitter <sup>(3),(4)</sup>	-	50	-	ps
Supply Current	-	35	55	mA
Operating Voltage Range	+3.0	+3.3	+3.6	Volts
Operating Case Temperature Range	0	-	80	°C

## Notes:

- (1) Measured at  $-14$  dBm optical input power with output connected into  $R_L = 100\Omega$  (differential)
- (2) Measured at  $10^{-10}$  BER with a  $2^7-1$  PRBS at 2.125 Gb/s
- (3) Measured with a  $2^7-1$  PRBS at 2.125 Gb/s, an input optical power of  $-3$  dBm and  $R_L = 100\Omega$  (differential)
- (4)  $6\sigma$  about the center eye crossing

AMT8304

PERFORMANCE DATA

Figure 3: Eye Diagram with an Optical Input Power of  $-19\text{dBm}$  (with a 4GHz LPF)

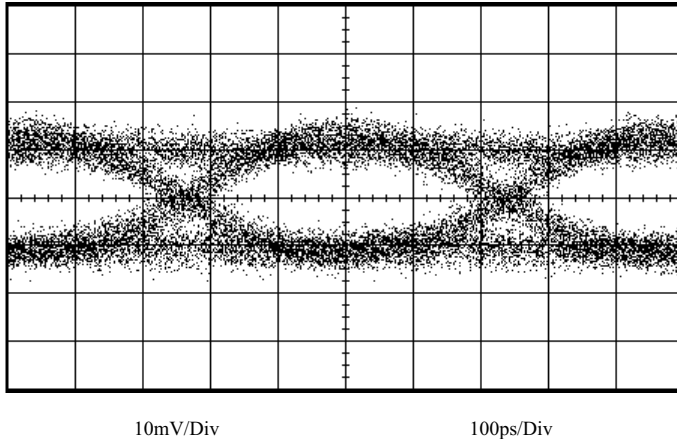

Figure 4: Eye Diagram with an Optical Input Power of  $-9.0\text{dBm}$

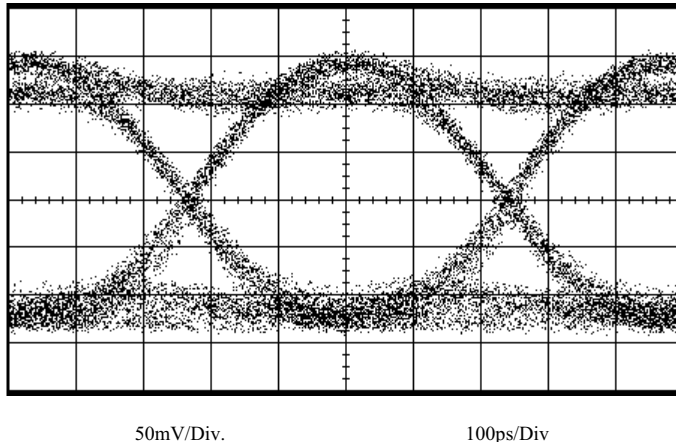

Figure 5: Eye Diagram with an Optical Input Power of  $0\text{dBm}$

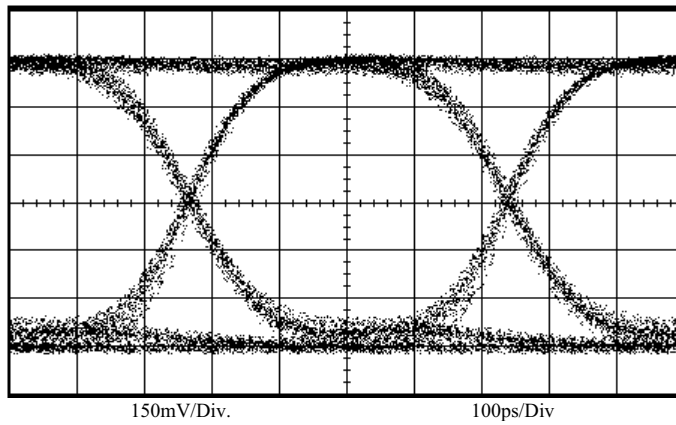

Figure 6: Supply Current vs. Temperature

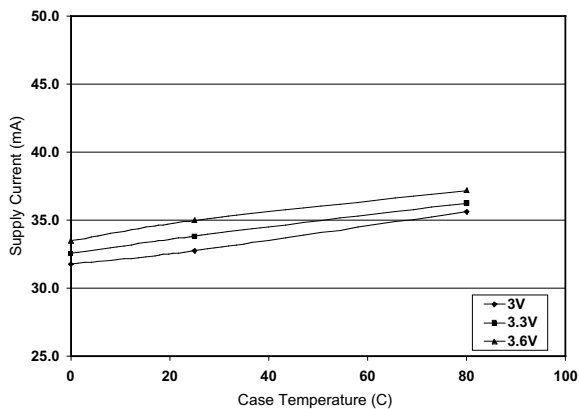

Figure 7: Bandwidth vs. Temperature

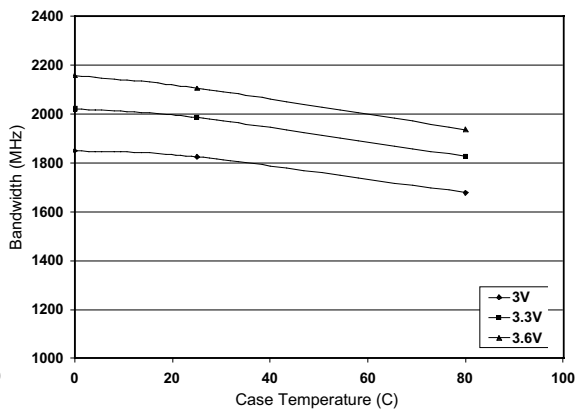

Figure 8: Differential Responsivity vs. Temperature

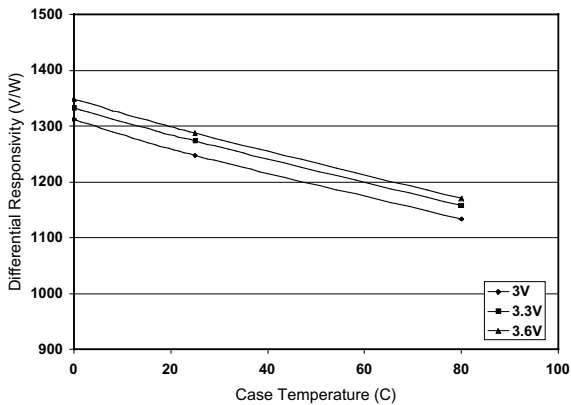
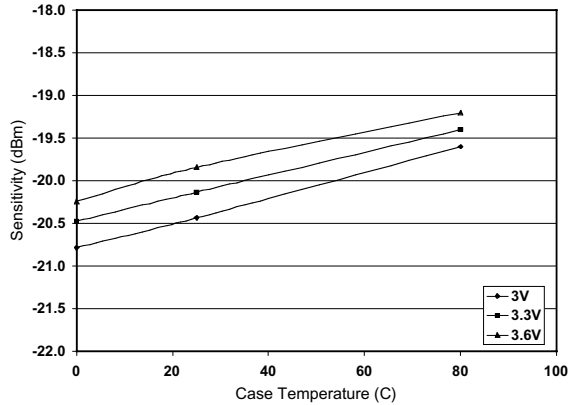

Figure 9: Sensitivity vs. Temperature



MEASUREMENT METHODS

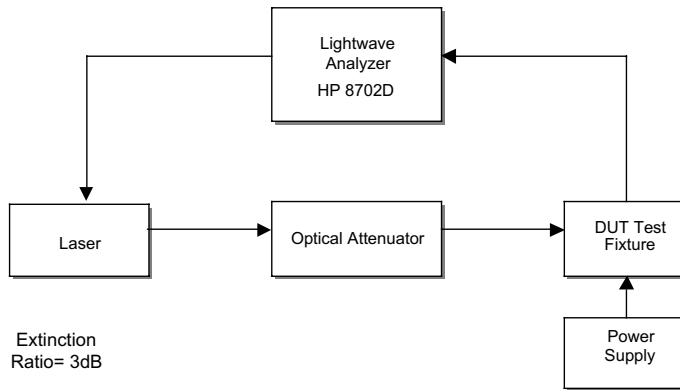

Figure 11: Test Setup for Frequency Response

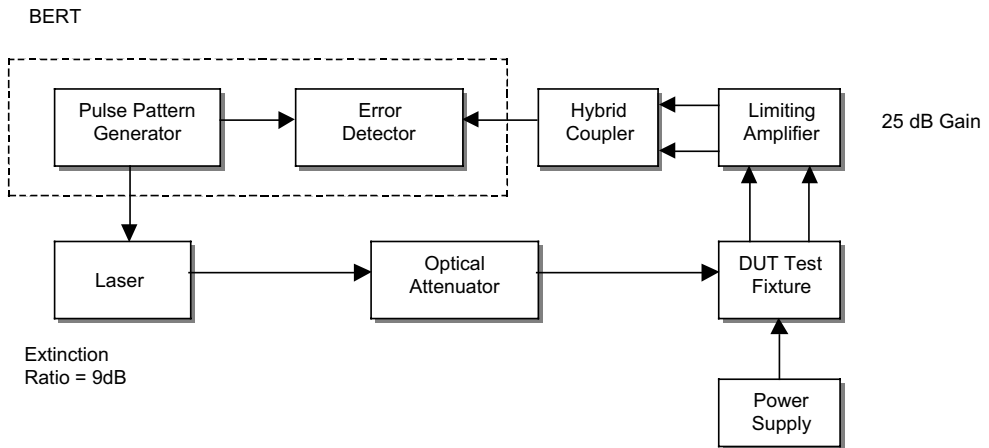

Figure 12: Test Setup for Sensitivity

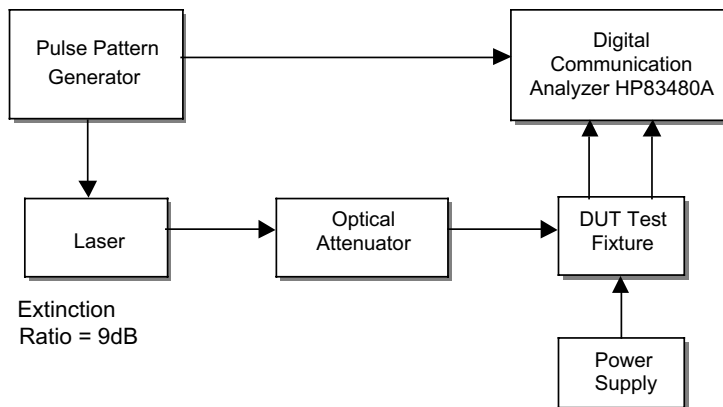

Figure 13: Test Setup for Eye Measurements

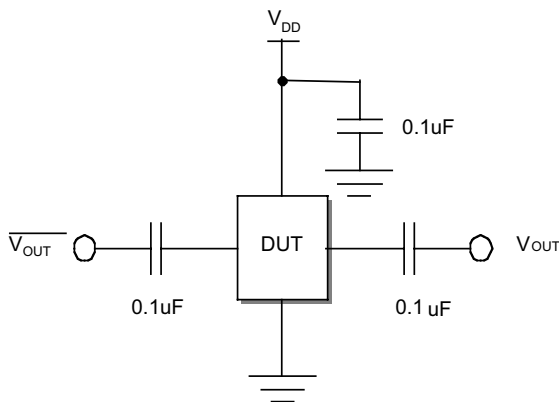

Figure 13: DUT Test Fixture Schematic

APPLICATION INFORMATION

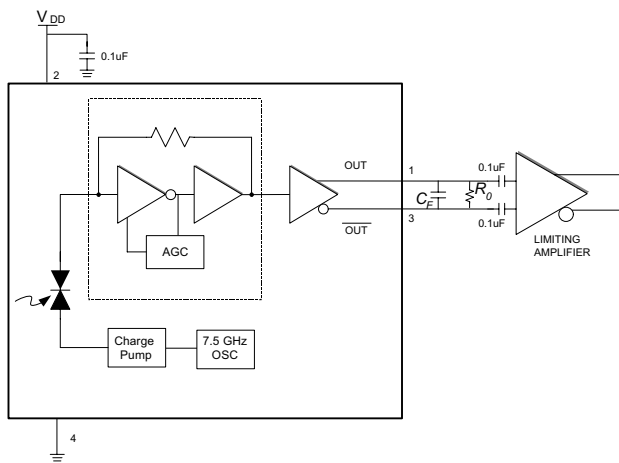

Figure 14: Application Schematic

$C_F$  is an optional single pole noise filter

$$C_F = \frac{1}{2\pi f_c R}$$

$f_c$  is the desired cutoff frequency

$$R = 50 \Omega$$

$R_O$  is required with high input resistance limiting amplifiers

$$R_O = 100 \Omega$$

**AMT8304**

**PACKAGE OUTLINE**

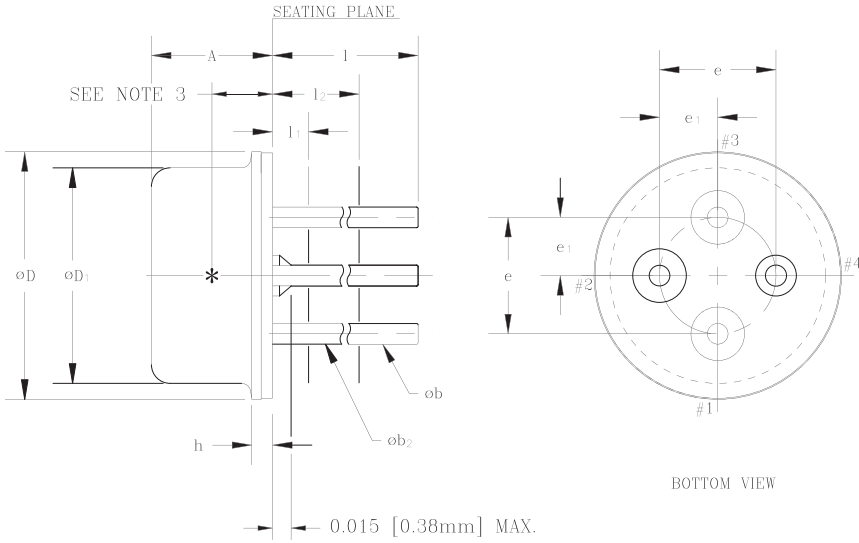

MM CONTROLLING DIMENSIONS

SYMBOL	INCHES		MILLIMETERS		NOTE
	MIN.	MAX.	MIN.	MAX.	
A	0.098	0.110	2.50	2.80	
ob	0.016	0.020	0.41	0.51	1
ob <sub>2</sub>	0.012	0.019	0.30	0.48	1
OD	0.212	0.218	5.38	5.54	
OD <sub>1</sub>	0.181	0.187	4.60	4.75	
e	0.100	T.P.	2.54	T.P.	2
e <sub>1</sub>	0.050	T.P.	1.27	T.P.	2
h	0.014	0.022	0.36	0.56	
l	0.500	0.540	12.70	13.70	1
l <sub>1</sub>	—	0.050	—	1.27	1
l <sub>2</sub>	0.250	—	6.35	—	1

NOTES:

- (FOUR LEADS) ob<sub>2</sub> APPLIES BETWEEN l<sub>1</sub> AND l<sub>2</sub>. ob APPLIES BETWEEN l<sub>2</sub> AND 0.5 [12.70mm] FROM SEATING PLANE. DIAMETER IS UNCONTROLLED IN l<sub>1</sub> AND BEYOND 0.5 [12.70mm] TO END OF PIN.
- MAXIMUM DIAMETER LEADS AT A GAGING PLANE 0.054 [1.37mm]+0.001 [0.025mm] -0.000 [0.000mm] BELOW SEATING PLANE TO BE WITHIN 0.007 [0.178mm] OF THEIR TRUE POSITION RELATIVE TO MAXIMUM-WIDTH TAB AND TO THE MAXIMUM 0.212 [5.40mm] DIAMETER MEASURED WITH A SUITABLE GAGE. WHEN GAGE IS NOT USED, MEASUREMENT WILL BE MADE AT 0.250 [6.35mm] FROM SEATING PLANE.
- INTERNAL OPTICAL HEIGHT = 0.052±0.003[1.31±.08]
- BENT LEADS SHOULD NOT EXTEND OUTSIDE DIAMETER (OD) OF CAP OR TOUCH EACH OTHER.
- ALL DIMENSIONS ARE REFERENCE ONLY—EXCEPT A, D & h.
- DETECTOR DIODE PLACEMENT ACCURACY  $\oplus$  0.15MM[0.006] WITH RESPECT TO CENTER OF HEADER.(REF.ONLY)

**Figure 15: T46F Package Outline Diagram**

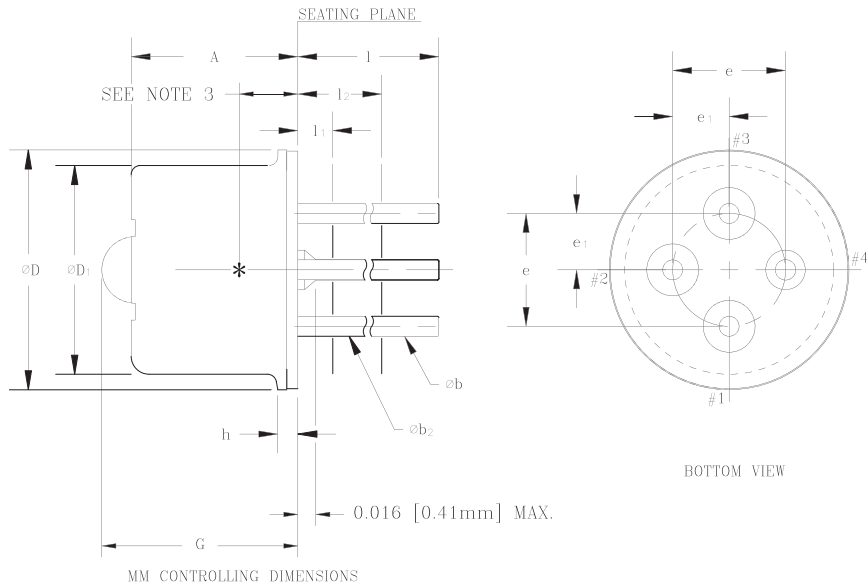

MM CONTROLLING DIMENSIONS

$S_{M,B,Q}$	INCHES		MILLIMETERS		NOTE
	MIN.	MAX.	MIN.	MAX.	
A	--	0.160	--	4.00	
$\varnothing b$	0.016	0.020	0.41	0.51	1
$\varnothing b_2$	0.012	0.019	0.30	0.48	1
$\varnothing D$	0.212	0.218	5.38	5.54	
$\varnothing D$	0.181	0.187	4.60	4.75	
e	0.100 T.P.		2.54 T.P.		2
$e_1$	0.050 T.P.		1.27 T.P.		2
h	0.014	0.022	0.36	0.56	
L	0.500	0.540	12.70	13.70	1
$L_1$	--	0.050	--	1.27	1
$L_2$	0.250	--	6.35	--	1
G	--	0.190	--	4.66	7

NOTES:

- (FOUR LEADS)  $\varnothing b_2$  APPLIES BETWEEN  $L_1$  AND  $L_2$ .  $\varnothing b$  APPLIES BETWEEN  $L_2$  AND 0.5 [12.70mm] FROM SEATING PLANE. DIAMETER IS UNCONTROLLED IN  $L_1$  AND BEYOND 0.5 [12.70mm] TO END OF PIN.
- MAXIMUM DIAMETER LEADS AT A GAGING PLANE 0.054 [1.37mm]+0.001 [0.025mm] -0.000 [0.000mm] BELOW SEATING PLANE TO BE WITHIN 0.007 [0.178mm] OF THEIR TRUE POSITION RELATIVE TO MAXIMUM-WIDTH TAB AND TO THE MAXIMUM 0.212 [5.40mm] DIAMETER MEASURED WITH A SUITABLE GAGE. WHEN GAGE IS NOT USED, MEASUREMENT WILL BE MADE AT 0.250 [6.35mm] FROM SEATING PLANE.
- INTERNAL OPTICAL HEIGHT =  $0.052 \pm 0.003$  [1.32 ± 0.08] DIE PLACEMENT ACCURACY FOR REF. ONLY.
- BENT LEADS SHOULD NOT EXTEND OUTSIDE DIAMETER ( $\varnothing D$ ) OF CAP OR TOUCH EACH OTHER.
- ALL DIMENSIONS ARE REFERENCE ONLY—EXCEPT A, D & h.
- DETECTOR DIODE PLACEMENT ACCURACY  $\varnothing \pm 0.15$ MM [0.006] ALL DIRECTIONS
- LENS HEIGHT =  $0.65 \pm 0.1$  [0.026 ± 0.004]

Figure 16: T46L Package Outline Diagram

AMT8304

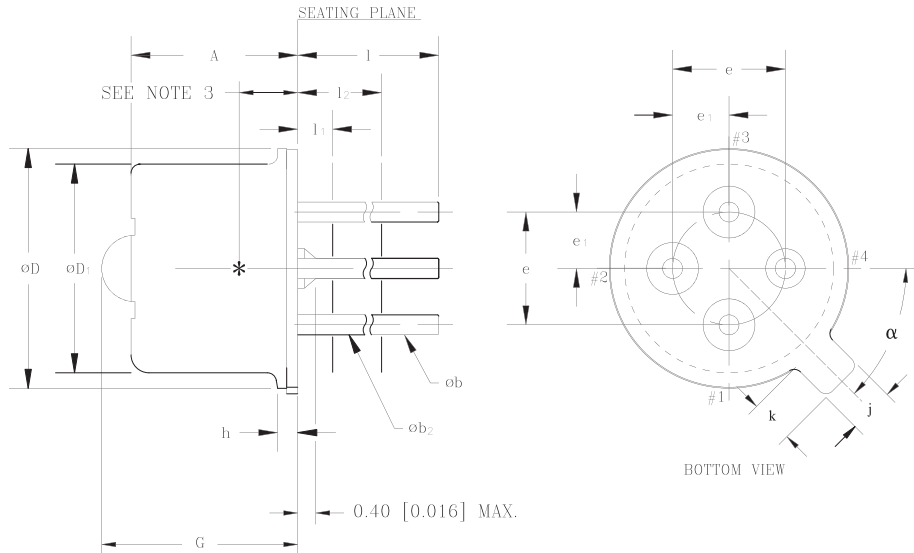

MM CONTROLLING DIMENSIONS

DIMENSIONS	MILLIMETERS		INCHES		NOTE
	MIN.	MAX.	MIN.	MAX.	
A	--	4.00	--	0.160	
ob	0.41	0.51	0.016	0.020	1
ob <sub>2</sub>	0.30	0.48	0.012	0.019	1
od	5.38	5.54	0.212	0.218	
od <sub>1</sub>	4.60	4.75	0.181	0.187	
e	2.54	T.P.	0.100	T.P.	2
e <sub>1</sub>	1.27	T.P.	0.050	T.P.	2
h	0.36	0.56	0.014	0.022	
j	0.92	1.12	0.036	0.044	
k	0.81	1.04	0.032	0.041	
l	12.70	13.70	0.500	0.540	1
l <sub>1</sub>	--	1.27	--	0.050	1
l <sub>2</sub>	6.35	--	0.250	--	1
G	--	4.66	--	0.190	7
α	45°	T.P.	45°	T.P.	

NOTES:

- (FOUR LEADS) ob<sub>2</sub> APPLIES BETWEEN l<sub>1</sub> AND l<sub>2</sub>. ob APPLIES BETWEEN l<sub>2</sub> AND 12.70 [0.50] FROM SEATING PLANE. DIAMETER IS UNCONTROLLED IN l<sub>1</sub> AND BEYOND 12.70 [0.50] TO END OF PIN.
- MAXIMUM DIAMETER LEADS AT A GAGING PLANE 1.37 +0.025/-0.000 [0.054+0.001/-0.000] BELOW SEATING PLANE TO BE WITHIN 0.178 [0.007] OF THEIR TRUE POSITION RELATIVE TO MAXIMUM-WIDTH TAB AND TO THE MAXIMUM 5.40 [0.212] DIAMETER MEASURED WITH A SUITABLE GAGE. WHEN GAGE IS NOT USED, MEASUREMENT WILL BE MADE AT 6.35 [0.25] FROM SEATING PLANE.
- INTERNAL OPTICAL HEIGHT = 1.32±0.08 [0.052±0.003] DIE PLACEMENT ACCURACY FOR REF. ONLY.
- BENT LEADS SHOULD NOT EXTEND OUTSIDE DIAMETER (od) OF CAP OR TOUCH EACH OTHER.
- ALL DIMENSIONS ARE REFERENCE ONLY-EXCEPT A, D & h.
- DETECTOR DIODE PLACEMENT ACCURACY ⊕ 0.15 [0.006] ALL DIRECTIONS
- LENS HEIGHT = 0.65±0.1 [0.026±0.004]

Figure 17: T4TL Package Outline Diagram

NOTES

## AMT8304

### ORDERING INFORMATION

ORDER NUMBER	PACKAGE OPTION	PACKAGE DESCRIPTION
AMT8304T46F	TO-46F	Ultra Flat Window Package
AMT8304T46L	TO-46L	Lens Package
AMT8304T4TL	TO-46L	Lens Package with Tabbed Header



#### **ANADIGICS, Inc.**

141 Mount Bethel Road

Warren, New Jersey 07059, U.S.A.

Tel: +1 (908) 668-5000

Fax: +1 (908) 668-5132

URL: <http://www.anadigics.com>

E-mail: [Mktg@anadigics.com](mailto:Mktg@anadigics.com)

#### **IMPORTANT NOTICE**

ANADIGICS, Inc. reserves the right to make changes to its products or to discontinue any product at any time without notice. The product specifications contained in Advanced Product Information sheets and Preliminary Data Sheets are subject to change prior to a product's formal introduction. Information in Data Sheets have been carefully checked and are assumed to be reliable; however, ANADIGICS assumes no responsibilities for inaccuracies. ANADIGICS strongly urges customers to verify that the information they are using is current before placing orders.

#### **WARNING**

ANADIGICS products are not intended for use in life support appliances, devices or systems. Use of an ANADIGICS product in any such application without written consent is prohibited.