

S6A2067

80 SEG DRIVER FOR STN LCD

Jan. 2002.

Ver. 0.1

Contents in this document are subject to change without notice. No part of this document may be reproduced or transmitted in any form or by any means, electronic or mechanical, for any purpose, without the express written permission of LCD Driver IC Team.

Precautions for Light

Light has characteristics to move electrons in the integrated circuitry of semiconductors, therefore may change the characteristics of semiconductor devices when irradiated with light. Consequently, the users of the packages which may expose chips to external light such as COB, COG, TCP and COF must consider effective methods to block out light from reaching the IC on all parts of the surface area, the top, bottom and the sides of the chip. Follow the precautions below when using the products.

1. Consider and verify the protection of penetrating light to the IC at substrate (board or glass) or product design stage.
2. Always test and inspect products under the environment with no penetration of light.

INTRODUCTION

The S6A2067 is a LCD driver IC which is fabricated by low power CMOS technology. Basically this LSI consists of 40 x 2 bit bi-directional shift register, 40 x 2 bit data latch and 40 x 2 bit LCD driver (refer to Figure 1). This IC can be used as segment driver.

FUNCTION

- Dot matrix LCD driver with 80 channel output.
- Input/Output signal
 - Output: 40 x 2 channel waveform for LCD driving
 - Input: Serial display data and control signal pulse from the controller IC.
- Bias voltage (V1 to V4)

FEATURES

- Display driving bias: static - 1/5
- Power supply voltage: 2.7V to 5.5V
- Supply voltage for display: 3.0V to 13.0V ($V_{LCD} = V_{DD} - V_{EE}$)
- Interface

Driver (cascade connection)	Controller
S6A0065, Other S6A2067	S6A0069 S6A0070 S6A0073

- CMOS Process
- 100QFP or bare chip available

BLOCK DIAGRAM

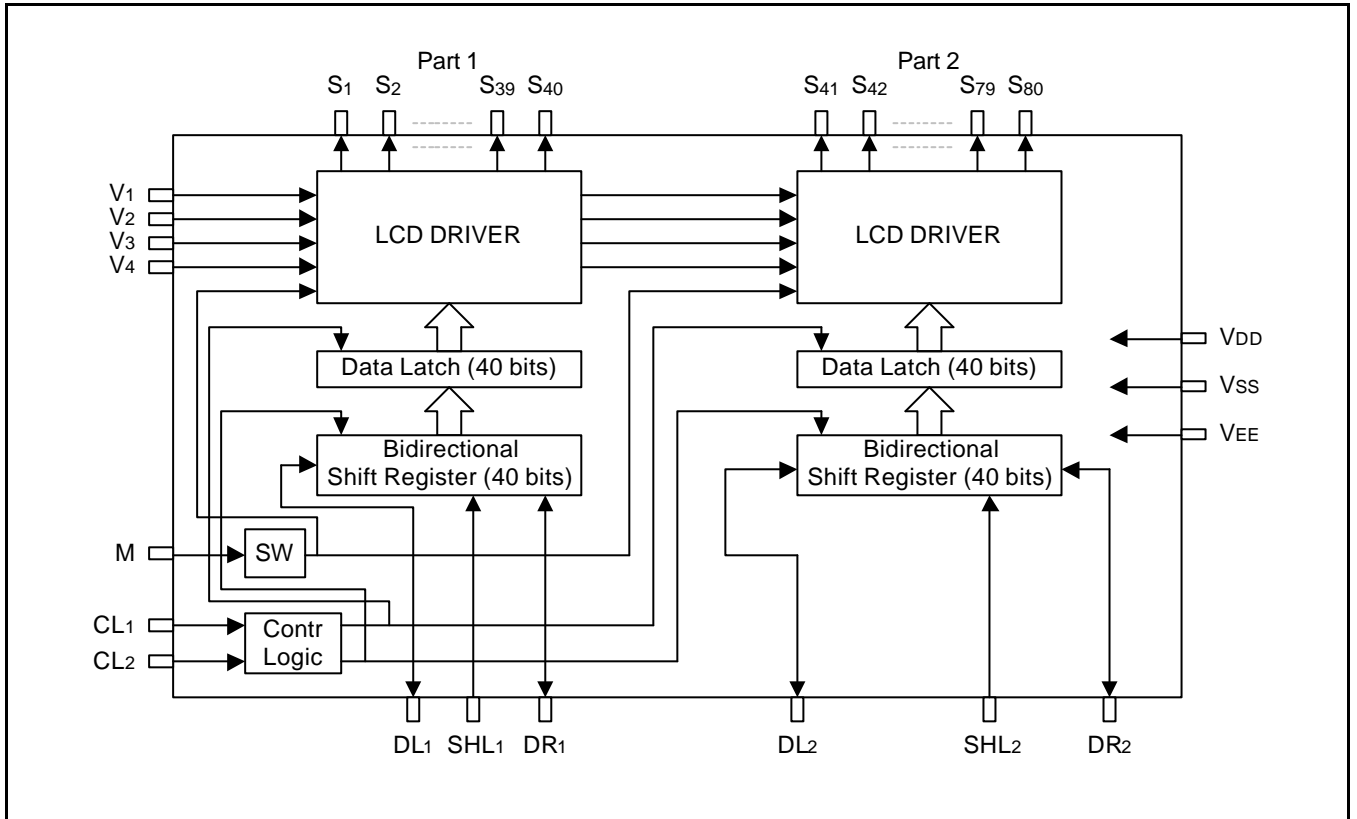

Figure 1. S6A2067 Functional Block Diagram

PIN CONFIGURATION

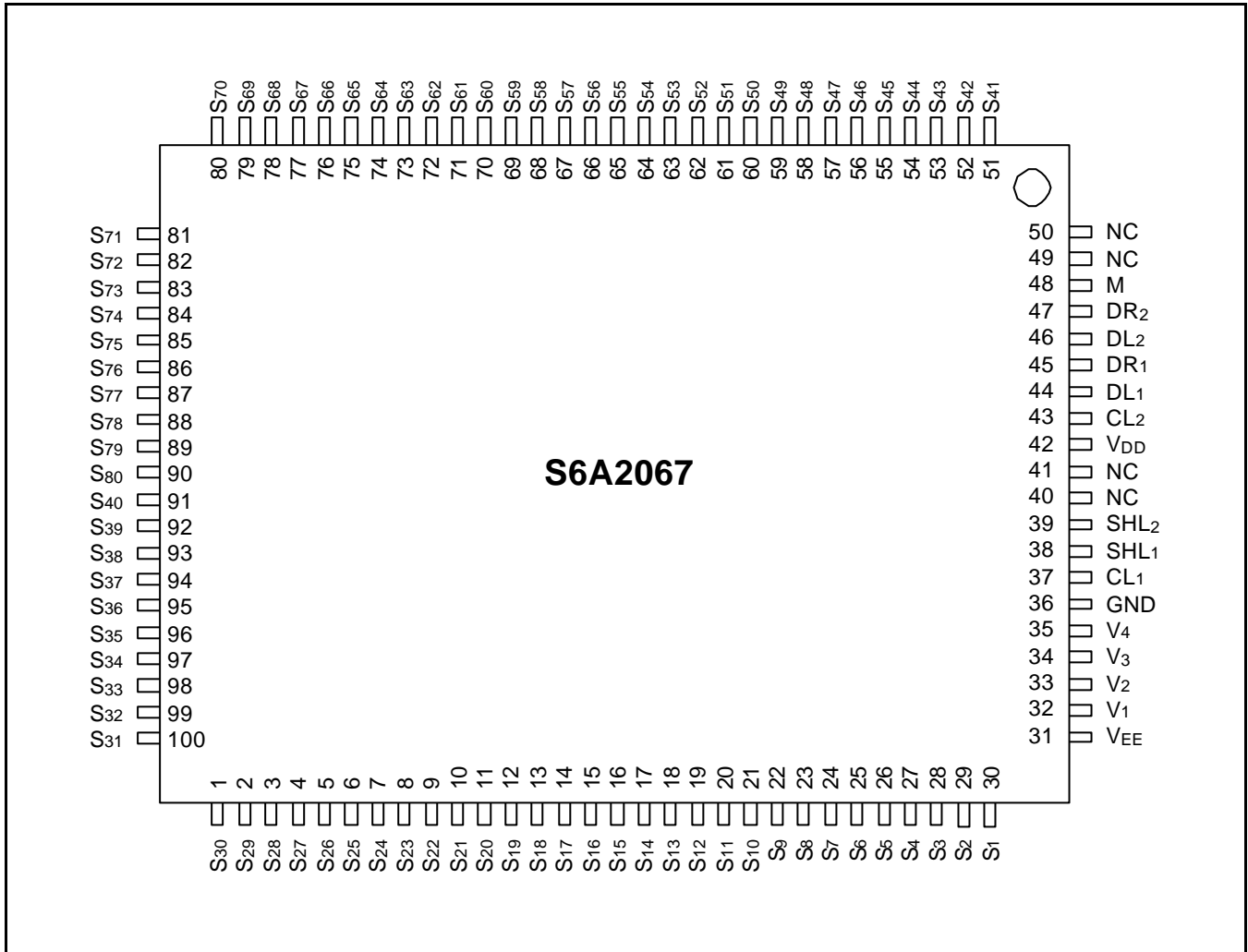
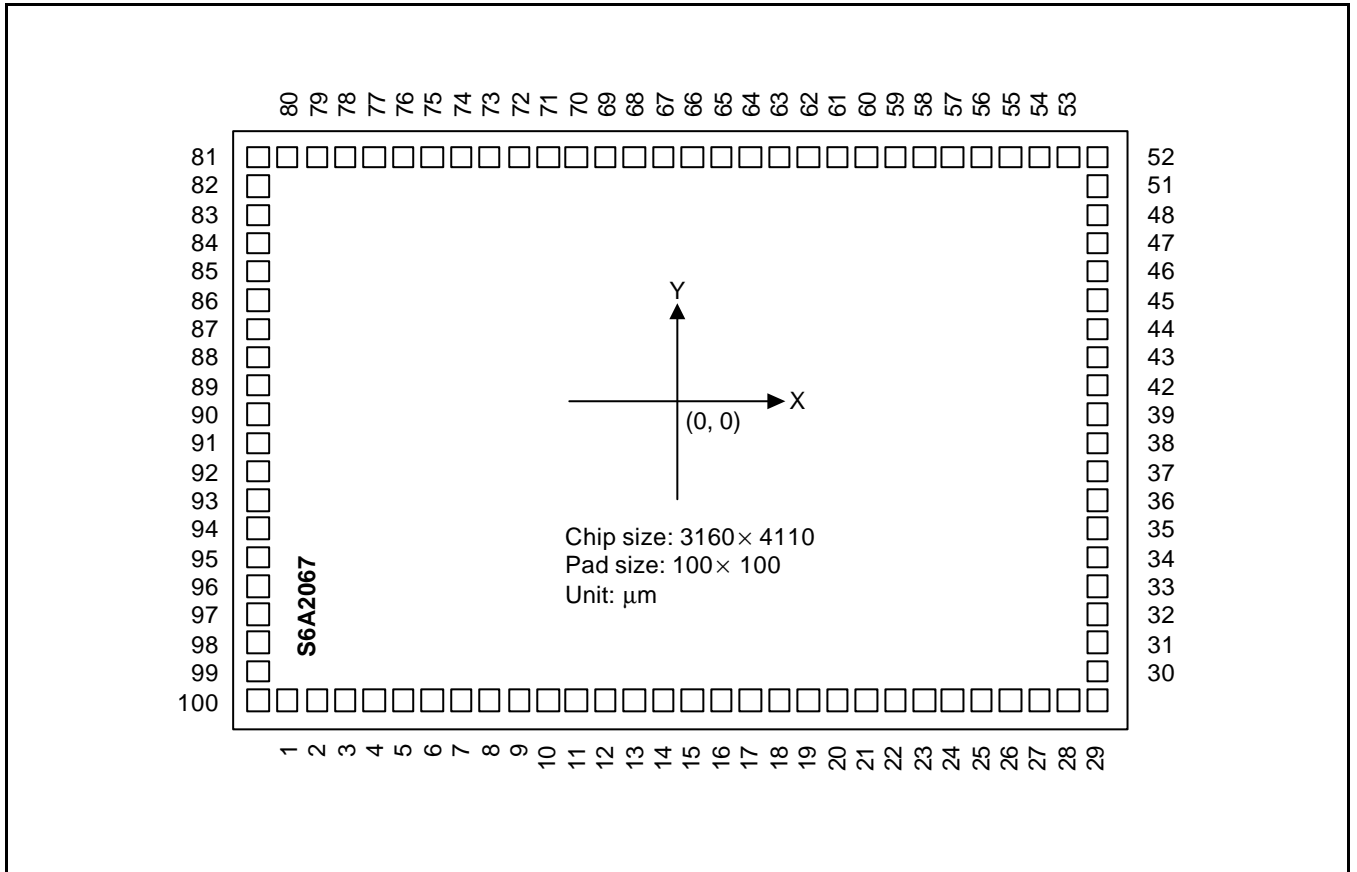

Figure 2. 100 QFP Top View

PAD DIAGRAM



PAD CENTER COORDINATES

Pad	Pad	Coordinate		Pad	Pad	Coordinate		Pad	Pad	Coordinate	
Num.	Name	X	Y	Num.	Name	X	Y	Num.	Name	X	Y
1	S30	-1352	1687	33	V2	-712	-1827	69	S59	1352	312
2	S29	-1352	1562	34	V3	-587	-1827	70	S60	1352	437
3	S28	-1352	1437	35	V4	-462	-1827	71	S61	1352	562
4	S27	-1352	1312	36	V5	-313	-1827	72	S62	1352	687
5	S26	-1352	1187	37	CL1	-188	-1827	73	S63	1352	812
6	S25	-1352	1062	38	SHL1	-63	-1827	74	S64	1352	937
7	S24	-1352	937	39	SHL2	62	-1827	75	S65	1352	1062
8	S23	-1352	812	42	VDD	187	-1827	76	S66	1352	1187
9	S22	-1352	687	43	CL2	312	-1827	77	S67	1352	1312
10	S21	-1352	562	44	DL1	437	-1827	78	S68	1352	1437
11	S20	-1352	437	45	DR1	562	-1827	79	S69	1352	1562
12	S19	-1352	312	46	DL2	687	-1827	80	S70	1352	1687
13	S18	-1352	187	47	DR2	812	-1827	81	S71	1352	1812
14	S17	-1352	62	48	M	937	-1827	82	S72	1062	1827
15	S16	-1352	-63	51	S41	1086	-1827	83	S73	937	1827
16	S15	-1352	-188	52	S42	1352	-1813	84	S74	812	1827
17	S14	-1352	-313	53	S43	1352	-1688	85	S75	687	1827
18	S13	-1352	-438	54	S44	1352	-1563	86	S76	562	1827
19	S12	-1352	-563	55	S45	1352	-1438	87	S77	437	1827
20	S11	-1352	-688	56	S46	1352	-1313	88	S78	312	1827
21	S10	-1352	-813	57	S47	1352	-1188	89	S79	187	1827
22	S9	-1352	-938	58	S48	1352	-1063	90	S80	62	1827
23	S8	-1352	-1063	59	S49	1352	-938	91	S40	-63	1827
24	S7	-1352	-1188	60	S50	1352	-813	92	S39	-188	1827
25	S6	-1352	-1313	61	S51	1352	-688	93	S38	-313	1827
26	S5	-1352	-1438	62	S52	1352	-563	94	S37	-438	1827
27	S4	-1352	-1563	63	S53	1352	-438	95	S36	-563	1827
28	S3	-1352	-1688	64	S54	1352	-313	96	S35	-688	1827
29	S2	-1352	-1813	65	S55	1352	-188	97	S34	-813	1827
30	S1	-1087	-1827	66	S56	1352	-63	98	S33	-938	1827
31	VEE	-962	-1827	67	S57	1352	62	99	S32	-1063	1827
32	V1	-837	-1827	68	S58	1352	187	100	S31	-1352	1827

NOTE: S6A2067 Marking: easy to find the PAD No.6, No.90.

PIN DESCRIPTION

PIN (NO.)	I/O	Name	Description	Interface										
V _{DD} (42)	Power	Operating Voltage	For logical circuit (2.7 - .5V)	Power Supply										
V _{SS} (GND)(36)			0V (GND)											
V _{EE} (31)		Negative Supply Voltage	For LCD driver circuit											
V1, V2(32,33)	Input	LCD driver output voltage level	Bias voltage level for LCD drive (Select level)	Power										
V3, V4(34,35)	Input		Bias voltage level for LCD drive (Non-select level)											
S1 - S40	Output	Part 1	LCD driver	LCD										
SHL1(38)	Input		Data Interface	Selection of the shift direction of shift register <table border="1"> <thead> <tr> <th>SHL1</th> <th>DL1</th> <th>DR1</th> </tr> </thead> <tbody> <tr> <td>V_{DD}</td> <td>OUT</td> <td>IN</td> </tr> <tr> <td>V_{SS}</td> <td>IN</td> <td>OUT</td> </tr> </tbody> </table>	SHL1	DL1	DR1	V _{DD}	OUT	IN	V _{SS}	IN	OUT	V _{DD} or V _{SS}
SHL1	DL1		DR1											
V _{DD}	OUT	IN												
V _{SS}	IN	OUT												
DL1, DR1 (44,45)	Input Output	Data Input/output of shift register (part 1)	Controller or S6A2067/ S6A0065											
S41 - S80	Output	Part 2	LCD driver	LCD										
SHL2 (39)	Input		Data Interface	Selection of the shift direction of shift register <table border="1"> <thead> <tr> <th>SHL2</th> <th>DL2</th> <th>DR2</th> </tr> </thead> <tbody> <tr> <td>V_{DD}</td> <td>OUT</td> <td>IN</td> </tr> <tr> <td>V_{SS}</td> <td>IN</td> <td>OUT</td> </tr> </tbody> </table>	SHL2	DL2	DR2	V _{DD}	OUT	IN	V _{SS}	IN	OUT	V _{DD} or V _{SS}
SHL2	DL2		DR2											
V _{DD}	OUT	IN												
V _{SS}	IN	OUT												
DL2, DR2 (46,47)	Input Output	Data Input/output of shift register (part 2)	Controller or S6A2067/ S6A0065											
M(48)	Input	Alternated signal for LCD driver output	The alternating signal to convert LCD drive waveform to AC	Controller										
CL1, CL2 (37,43)	Input	Data shift/ latch clock	CL1 : Data latch clock CL2 : Data shift clock											
NC (40,41,49,50)			No connection	NC										

MAXIMUM ABSOLUTE LIMIT

($T_A = 25^\circ\text{C}$)

Characteristic	Symbol	Value	Unit
Operating Voltage	V_{DD}	-0.3 - +7.0	V
Driver Supply Voltage	V_{LCD}	$V_{DD}-15.0 - V_{DD}+0.3$	V
Input Voltage 1	V_{IN1}	-0.3 - $V_{DD}+0.3$	V
Input Voltage 2 (V1 - V4)	V_{IN2}	$V_{DD}+0.3 - V_{EE}-0.3$	V
Operating Temperature	T_{OPR}	-30 - +85	$^\circ\text{C}$
Storage Temperature	T_{STG}	-55 - +125	$^\circ\text{C}$

NOTES:

1. Voltage greater than above may damage the circuit
2. V_{EE} : connect a protection resistor ($220\Omega \pm 5\%$)

ELECTRICAL CHARACTERISTICS

DC Characteristics

($V_{DD} = 2.7$ to 5.5V , $V_{DD}-V_{EE} = 3 - 13\text{V}$, $V_{SS} = 0\text{V}$, $T_A = -30$ to 85°C)

Characteristic	Symbol	Test condition	Min	Max	Unit	Applicable pin
Operating Current	I_{DD}	$f_{CL2} = 400\text{kHz}$	-	1	mA	V_{DD} , V_{EE}
Supply Current	I_{EE}	$f_{CL1} = 1\text{kHz}$	-	10	μA	
Input High Voltage	V_{IH}	-	$0.7V_{DD}$	V_{DD}	V	CL1, CL2, DL1, DL2, DR1, DR2,
Input Low Voltage	V_{IL}		0	$0.3V_{DD}$		
Input Leakage Current	I_{LKG}	$V_{IN} = 0 - V_{DD}$	-5	5	μA	SHL1, SHL2, M
Output High Voltage	V_{OH}	$I_{OH} = -0.4\text{mA}$	$V_{DD}-0.4$	-	V	DL1, DL2, DR1, DR2 V (V1-V4)-S (S1-S80)
Output Low Voltage	V_{OL}	$I_{OL} = +0.4\text{mA}$		0.4		
Voltage Descending	V_{D1}	$I_{ON} = 0.1\text{mA}$ for one of S1 - S80	-	1.1		
	V_{D2}	$I_{ON} = 0.05\text{mA}$ for each S1 - S80	-	1.5		
Leakage Current	I_V	$V_{IN} = V_{DD} - V_{EE}$ (Output S1 - S80: floating)	-10	10	μA	V1 - V4

AC Characteristics

($V_{DD} = 2.7$ to $5.5V$, $V_{DD}-V_{EE} = 3 - 13V$, $V_{SS} = 0V$, $T_A = -30$ to $85^\circ C$)

Characteristic	Symbol	Test condition	Min	Max	Unit	Applicable pin
Data Shift Frequency	f_{CL}	–	–	400	kHz	CL2
Clock High Level Width	t_{WCKH}	–	800	–	ns	CL1, CL2
Clock Low Level Width	t_{WCKL}	–	800	–		CL2
Clock Set-up Time	t_{SL}	from CL ₂ to CL ₁	500	–		CL1,CL2
	t_{LS}	from CL ₁ to CL ₂	500	–		
Clock Rise/Fall Time	t_R/t_F	–	–	200		
Data Set-up Time	t_{SU}	–	300	–		DL1,DL2,DR1,DR2
Data Hold Time	t_{DH}	–	300	–		DL1,DL2,DR1,DR2
Data Delay Time	t_D	$C_L = 15pF$	–	500		DL1,DL2,DR1,DR2

TIMING CHARACTERISTICS

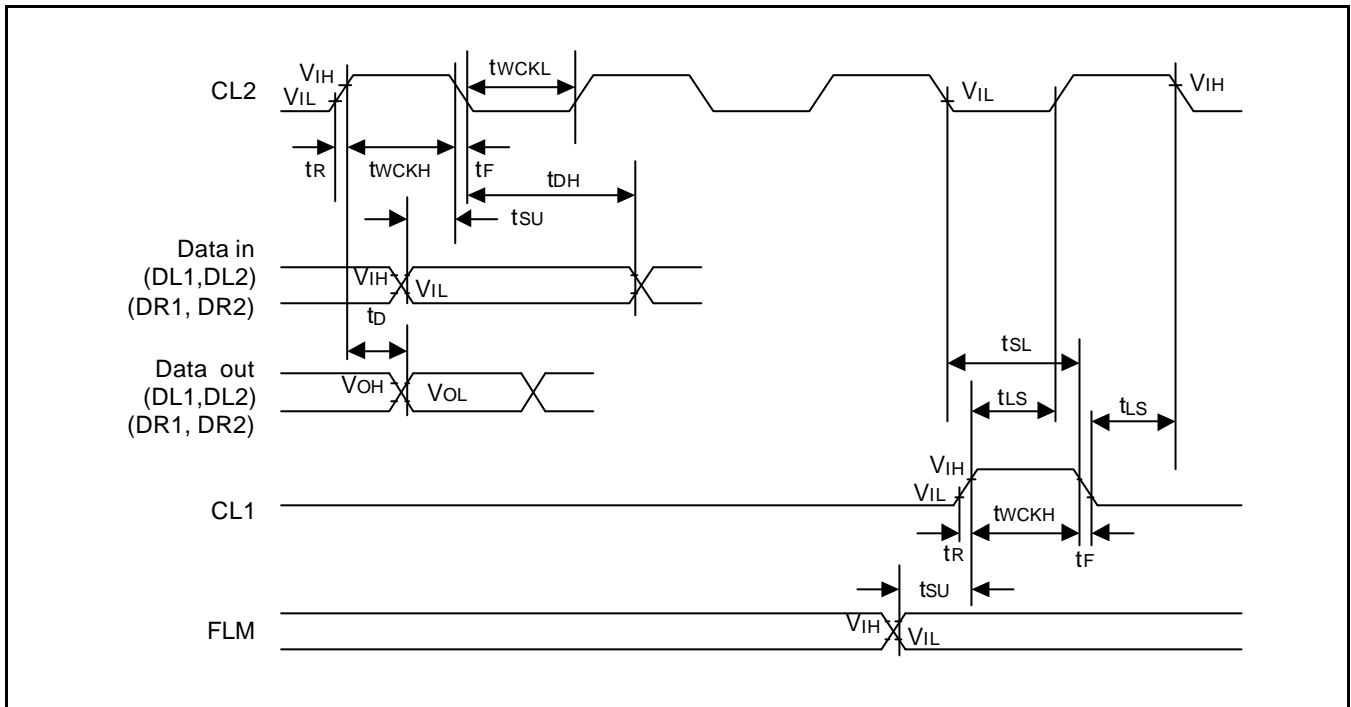
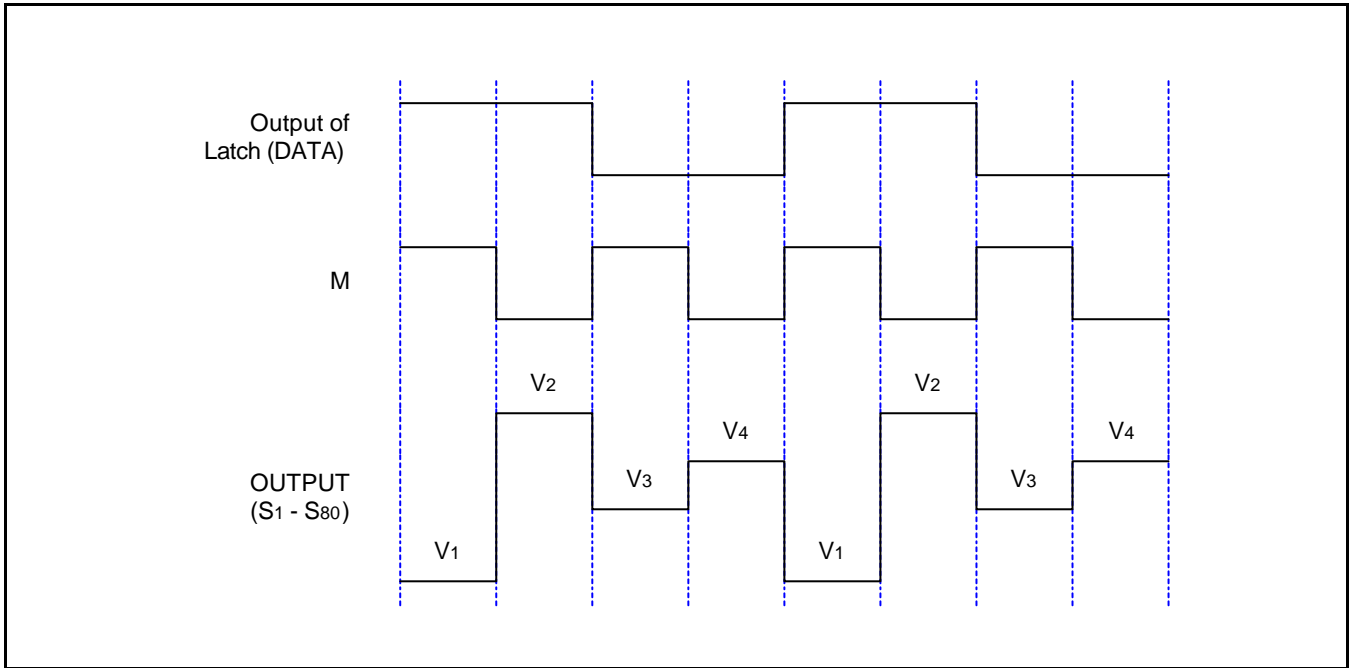

Figure 3. AC Characteristics

LCD OUTPUT WAVEFORMS



APPLICATION CIRCUIT

