



400ksp/300ksp, Single-Supply, Low-Power, Serial 10-Bit ADCs with Internal Reference

General Description

The MAX1084/MAX1085 10-bit analog-to-digital converters (ADCs) combine a high-bandwidth track/hold, a serial interface with high conversion speed, an internal +2.5V reference, and low power consumption. The MAX1084 operates from a single +4.5V to +5.5V supply; the MAX1085 operates from a single +2.7V to +3.6V supply.

The 3-wire serial interface connects directly to SPI™/QSPI™/MICROWIRE™ devices without external logic. The devices use an external serial-interface clock to perform successive-approximation analog-to-digital conversions.

Low power combined with ease of use and small package size make these converters ideal for remote-sensor and data-acquisition applications, or for other circuits with demanding power consumption and space requirements. The MAX1084/MAX1085 are available in 8-pin SO packages.

These devices are pin-compatible, higher-speed versions of the MAX1242/MAX1243; for more information, refer to the respective data sheets.

Applications

- Portable Data Logging
- Data Acquisition
- Medical Instruments
- Battery-Powered Instruments
- Pen Digitizers
- Process Control

Pin Configuration

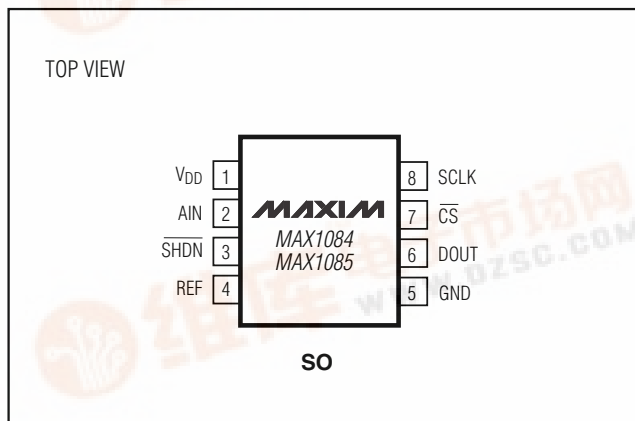

SPI and QSPI are trademarks of Motorola, Inc.

MICROWIRE is a trademark of National Semiconductor Corp.

Features

- ◆ Single-Supply Operation
 - +4.5V to +5.5V (MAX1084)
 - +2.7V to +3.6V (MAX1085)
- ◆ 10-Bit Resolution
- ◆ 400ksp Sampling Rate (MAX1084)
- ◆ Internal Track/Hold
- ◆ Internal +2.5V Reference
- ◆ Low Power: 2.5mA (400ksp)
- ◆ SPI/QSPI/MICROWIRE 3-Wire Serial Interface
- ◆ Pin-Compatible, High-Speed Upgrade to MAX1242/MAX1243
- ◆ 8-Pin SO Package

Ordering Information

PART	TEMP. RANGE	PIN-PACKAGE	INL (LSB)
MAX1084ACSA	0°C to +70°C	8 SO	±1/2
MAX1084BCSA	0°C to +70°C	8 SO	±1
MAX1084AESA	-40°C to +85°C	8 SO	±1/2
MAX1084BESA	-40°C to +85°C	8 SO	±1
MAX1085ACSA	0°C to +70°C	8 SO	±1/2
MAX1085BCSA	0°C to +70°C	8 SO	±1
MAX1085AESA	-40°C to +85°C	8 SO	±1/2
MAX1085BESA	-40°C to +85°C	8 SO	±1

Functional Diagram

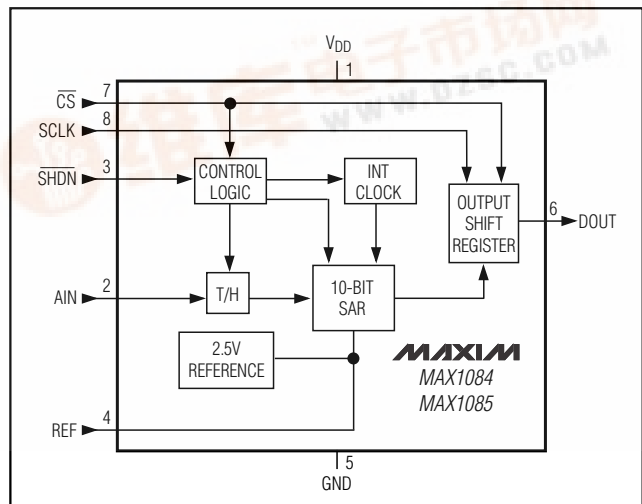

MAX1084/MAX1085

400ksp/s/300ksp/s, Single-Supply, Low-Power, Serial 10-Bit ADCs with Internal Reference

ABSOLUTE MAXIMUM RATINGS

V _{DD} to GND	-0.3V to +6V	Continuous Power Dissipation (T _A = +70°C)	
A _{IN} to GND	-0.3V to (V _{DD} + 0.3V)	8-Pin SO (derate 5.88mW/°C above +70°C)	471mW
REF to GND	-0.3V to (V _{DD} + 0.3V)	Operating Temperature Ranges	
Digital Inputs to GND	-0.3V to +6V	MAX1084_CSA/MAX1085_CSA	0°C to +70°C
DOUT to GND	-0.3V to (V _{DD} + 0.3V)	MAX1084_ESA/MAX1085_ESA	-40°C to +85°C
DOUT Current	±25mA	Storage Temperature Range	-60°C to +150°C
		Lead Temperature (soldering, 10s)	+300°C

Stresses beyond those listed under "Absolute Maximum Ratings" may cause permanent damage to the device. These are stress ratings only, and functional operation of the device at these or any other conditions beyond those indicated in the operational sections of the specifications is not implied. Exposure to absolute maximum rating conditions for extended periods may affect device reliability.

ELECTRICAL CHARACTERISTICS—MAX1084

(V_{DD} = +4.5V to +5.5V, f_{SCLK} = 6.4MHz, 50% duty cycle, 16 clocks/conversion cycle (400ksp/s), 4.7μF capacitor at REF, T_A = T_{MIN} to T_{MAX}, unless otherwise noted. Typical values are at T_A = +25°C.)

PARAMETER	SYMBOL	CONDITIONS	MIN	TYP	MAX	UNITS
DC ACCURACY (Note 1)						
Resolution			10			Bits
Relative Accuracy (Note 2)	INL	MAX1084A			±0.5	LSB
		MAX1084B			±1.0	
Differential Nonlinearity	DNL	No missing codes over temperature			±1.0	LSB
Offset Error					±4.0	LSB
Gain Error (Note 3)					±3.0	LSB
Gain-Error Temperature Coefficient				±0.8		ppm/°C
DYNAMIC SPECIFICATIONS (100kHz sine wave, 2.5Vp-p, clock = 6.4MHz)						
Signal-to-Noise Plus Distortion Ratio	SINAD			60		dB
Total Harmonic Distortion	THD	Up to the 5th harmonic		-70		dB
Spurious-Free Dynamic Range	SFDR			70		dB
Intermodulation Distortion	IMD	f _{IN1} = 99kHz, f _{IN2} = 102kHz		76		dB
Full-Power Bandwidth		-3dB point		6		MHz
Full-Linear Bandwidth		SINAD > 58dB		350		kHz
CONVERSION RATE						
Conversion Time (Note 4)	t _{CONV}		2.5			μs
Track/Hold Acquisition Time	t _{ACQ}				468	ns
Aperture Delay				10		ns
Aperture Jitter				<50		ps
Serial Clock Frequency	f _{SCLK}		0.5		6.4	MHz
Duty Cycle			40		60	%
ANALOG INPUT (A_{IN})						
Input Voltage Range	V _{A_{IN}}		0		2.5	V
Input Capacitance				18		pF

400ksp/300ksp, Single-Supply, Low-Power, Serial 10-Bit ADCs with Internal Reference

MAX1084/MAX1085

ELECTRICAL CHARACTERISTICS—MAX1084 (continued)

($V_{DD} = +4.5V$ to $+5.5V$, $f_{SCLK} = 6.4MHz$, 50% duty cycle, 16 clocks/conversion cycle (400ksp), 4.7 μF capacitor at REF, $T_A = T_{MIN}$ to T_{MAX} , unless otherwise noted. Typical values are at $T_A = +25^\circ C$.)

PARAMETER	SYMBOL	CONDITIONS	MIN	TYP	MAX	UNITS
INTERNAL REFERENCE						
REF Output Voltage	V_{REF}	$T_A = +25^\circ C$	2.48	2.50	2.52	V
REF Short-Circuit Current				30		mA
REF Output Tempco	TC V_{REF}			± 15		ppm/ $^\circ C$
Load Regulation (Note 5)		0 to 1.0mA output load		0.1	2.0	mV/mA
Capacitive Bypass at REF			4.7		10	μF
DIGITAL INPUTS (SCLK, \overline{CS}, \overline{SHDN})						
Input High Voltage	V_{INH}		3.0			V
Input Low Voltage	V_{INL}				0.8	V
Input Hysteresis	V_{HYST}			0.2		V
Input Leakage	I_{IN}	$V_{IN} = 0$ or V_{DD}			± 1	μA
Input Capacitance	C_{IN}			15		pF
DIGITAL OUTPUT (DOOUT)						
Output Voltage Low	V_{OL}	$I_{SINK} = 5mA$			0.4	V
Output Voltage High	V_{OH}	$I_{SOURCE} = 1mA$	4			V
Three-State Leakage Current	I_L	$\overline{CS} = 5V$			± 10	μA
Three-State Output Capacitance	C_{OUT}	$\overline{CS} = 5V$		15		pF
POWER SUPPLY						
Positive Supply Voltage (Note 6)	V_{DD}		4.5		5.5	V
Positive Supply Current (Note 7)	I_{DD}	$V_{DD} = 5.5V$		2.5	4.0	mA
Shutdown Supply Current	$I_{\overline{SHDN}}$	$SCLK = V_{DD}$, $\overline{SHDN} = GND$		2	10	μA
Power-Supply Rejection	PSR	$V_{DD} = 5V \pm 10\%$, midscale input		± 0.5	± 2.0	mV

ELECTRICAL CHARACTERISTICS—MAX1085

($V_{DD} = +2.7V$ to $+3.6V$, $f_{SCLK} = 4.8MHz$, 50% duty cycle, 16 clocks/conversion cycle (300ksp), 4.7 μF capacitor at REF, $T_A = T_{MIN}$ to T_{MAX} , unless otherwise noted. Typical values are at $T_A = +25^\circ C$.)

PARAMETER	SYMBOL	CONDITIONS	MIN	TYP	MAX	UNITS
DC ACCURACY (Note 1)						
Resolution			10			Bits
Relative Accuracy (Note 2)	INL	MAX1085A			± 0.5	LSB
		MAX1085B			± 1.0	
Differential Nonlinearity	DNL	No missing codes over temperature			± 1.0	LSB
Offset Error					± 3.0	LSB
Gain Error (Note 3)					± 3.0	LSB
Gain-Error Temperature Coefficient				± 1.6		ppm/ $^\circ C$

400ksp/300ksp, Single-Supply, Low-Power, Serial 10-Bit ADCs with Internal Reference

ELECTRICAL CHARACTERISTICS—MAX1085 (continued)

($V_{DD} = +2.7V$ to $+3.6V$, $f_{SCLK} = 4.8MHz$, 50% duty cycle, 16 clocks/conversion cycle (300ksp), $4.7\mu F$ capacitor at REF, $T_A = T_{MIN}$ to T_{MAX} , unless otherwise noted. Typical values are at $T_A = +25^\circ C$.)

PARAMETER	SYMBOL	CONDITIONS	MIN	TYP	MAX	UNITS
DYNAMIC SPECIFICATIONS (75kHz sinewave, 2.5Vp-p, $f_{SAMPLE} = 300ksp$, $f_{SCLK} = 4.8MHz$)						
Signal-to-Noise Plus Distortion Ratio	SINAD			60		dB
Total Harmonic Distortion	THD	Up to the 5th harmonic		-70		dB
Spurious-Free Dynamic Range	SFDR			70		dB
Intermodulation Distortion	IMD	$f_{IN1} = 99kHz$, $f_{IN2} = 102kHz$		76		dB
Full-Power Bandwidth		-3dB point		3		MHz
Full-Linear Bandwidth		SINAD > 58dB		250		kHz
CONVERSION RATE						
Conversion Time (Note 4)	t_{CONV}		3.3			μs
Track/Hold Acquisition Time	t_{ACQ}				625	ns
Aperture Delay				10		ns
Aperture Jitter				<50		ps
Serial Clock Frequency	f_{SCLK}		0.5		4.8	MHz
Duty Cycle			40		60	%
ANALOG INPUT						
Input Voltage Range	V_{AIN}		0		2.5	V
Input Capacitance	C_{IN}			18		pF
INTERNAL REFERENCE						
REF Output Voltage	V_{REF}	$T_A = +25^\circ C$	2.48	2.50	2.52	V
REF Short Circuit Current				15		mA
REF Output Tempco	TC V_{REF}			± 15		ppm/ $^\circ C$
Load Regulation (Note 5)		0 to 0.75mA output load		0.1	2.0	mV/mA
Capacitive Bypass at REF			4.7		10	μF
DIGITAL INPUTS (SCLK, \overline{CS} , \overline{SHDN})						
Input High Voltage	V_{INH}		2.0			V
Input Low Voltage	V_{INL}				0.8	V
Input Hysteresis	V_{HYST}			0.2		V
Input Leakage	I_{IN}	$V_{IN} = 0$ or V_{DD}			± 1	μA
Input Capacitance	C_{IN}			15		pF
DIGITAL OUTPUTS (DOUT)						
Output Voltage Low	V_{OL}	$I_{SINK} = 5mA$			0.4	V
Output Voltage High	V_{OH}	$I_{SOURCE} = 0.5mA$	$V_{DD} - 0.5V$			V
Three-State Leakage Current	I_L	$\overline{CS} = 3V$			± 10	μA
Three-State Output Capacitance	C_{OUT}	$\overline{CS} = 3V$		15		pF
POWER SUPPLY						
Positive Supply Voltage (Note 6)	V_{DD}		2.7		3.6	V
Positive Supply Current (Note 7)	I_{DD}	$V_{DD} = 3.6V$		2.5	3.5	mA
Shutdown Supply Current	I_{SHDN}	SCLK = V_{DD} , $\overline{SHDN} = GND$		2	10	μA
Power-Supply Rejection	PSR	$V_{DD} = 2.7V$ to $3.6V$, midscale input		± 0.5	± 2.0	mV

400ksp/300ksp, Single-Supply, Low-Power, Serial 10-Bit ADCs with Internal Reference

MAX1084/MAX1085

TIMING CHARACTERISTICS—MAX1084

(Figures 1, 2, 8, 9; $V_{DD} = +4.5V$ to $+5.5V$, $T_A = T_{MIN}$ to T_{MAX} , unless otherwise noted.)

PARAMETER	SYMBOL	CONDITIONS	MIN	TYP	MAX	UNITS
SCLK Period	t _{CP}		156			ns
SCLK Pulse Width High	t _{CH}		62			ns
SCLK Pulse Width Low	t _{CL}		62			ns
\overline{CS} Fall to SCLK Rise Setup	t _{CSS}		35			ns
SCLK Rise to \overline{CS} Rise Hold	t _{CSH}		0			ns
SCLK Rise to \overline{CS} Fall Ignore	t _{CSO}		35			ns
\overline{CS} Rise to SCLK Rise Ignore	t _{CS1}		35			ns
SCLK Rise to DOUT Hold	t _{DOH}	C _{LOAD} = 20pF	10			ns
SCLK Rise to DOUT Valid	t _{DOV}	C _{LOAD} = 20pF			80	ns
\overline{CS} Rise to DOUT Disable	t _{DOD}	C _{LOAD} = 20pF	10		65	ns
\overline{CS} Fall to DOUT Enable	t _{DOE}	C _{LOAD} = 20pF			65	ns
\overline{CS} Pulse Width High	t _{CSW}		100			ns

TIMING CHARACTERISTICS—MAX1085

(Figures 1, 2, 8, 9; $V_{DD} = +2.7V$ to $+3.6V$, $T_A = T_{MIN}$ to T_{MAX} , unless otherwise noted.)

PARAMETER	SYMBOL	CONDITIONS	MIN	TYP	MAX	UNITS
SCLK Period	t _{CP}		208			ns
SCLK Pulse Width High	t _{CH}		83			ns
SCLK Pulse Width Low	t _{CL}		83			ns
\overline{CS} Fall to SCLK Rise Setup	t _{CSS}		45			ns
SCLK Rise to \overline{CS} Rise Hold	t _{CSH}		0			ns
SCLK Rise to \overline{CS} Fall Ignore	t _{CSO}		45			ns
\overline{CS} Rise to SCLK Rise Ignore	t _{CS1}		45			ns
SCLK Rise to DOUT Hold	t _{DOH}	C _{LOAD} = 20pF	13			ns
SCLK Rise to DOUT Valid	t _{DOV}	C _{LOAD} = 20pF			100	ns
\overline{CS} Rise to DOUT Disable	t _{DOD}	C _{LOAD} = 20pF	13		85	ns
\overline{CS} Fall to DOUT Enable	t _{DOE}	C _{LOAD} = 20pF			85	ns
\overline{CS} Pulse Width High	t _{CSW}	C _{LOAD} = 20pF	100			ns

Note 1: Tested at $V_{DD} = V_{DD,MIN}$.

Note 2: Relative accuracy is the deviation of the analog value at any code from its theoretical value after the full-scale range has been calibrated.

Note 3: Internal reference, offset, and reference errors nulled.

Note 4: Conversion time is defined as the number of clock cycles multiplied by the clock period; clock has 50% duty cycle.

Note 5: External load should not change during conversion for specified accuracy. Guaranteed specification limit of 2mV/mA due to production test limitation.

Note 6: Electrical characteristics are guaranteed from $V_{DD,MIN}$ to $V_{DD,MAX}$. For operations beyond this range, see *Typical Operating Characteristics*.

Note 7: MAX1084 tested with 20pF on DOUT and $f_{SCLK} = 6.4MHz$, 0 to 5V. MAX1085 tested with same loads, $f_{SCLK} = 4.8MHz$, 0 to 3V. DOUT = full scale.

400kps/300kps, Single-Supply, Low-Power, Serial 10-Bit ADCs with Internal Reference

Typical Operating Characteristics

(MAX1084: $V_{DD} = +5.0V$, $f_{SCLK} = 6.4MHz$; MAX1085: $V_{DD} = +3.0V$, $f_{SCLK} = 4.8MHz$; $C_{LOAD} = 20pF$, $4.7\mu F$ capacitor at REF, $T_A = +25^\circ C$, unless otherwise noted.)

INTEGRAL NONLINEARITY vs. DIGITAL OUTPUT CODE

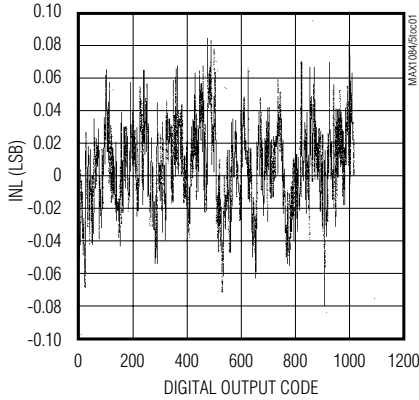

DIFFERENTIAL NONLINEARITY vs. DIGITAL OUTPUT CODE

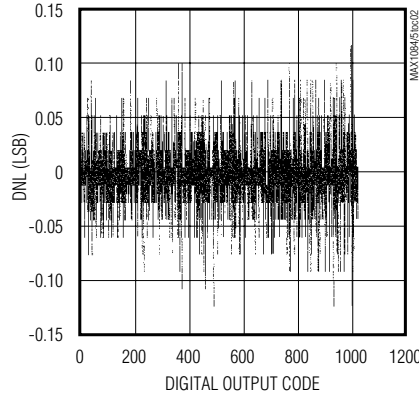

OFFSET ERROR vs. SUPPLY VOLTAGE

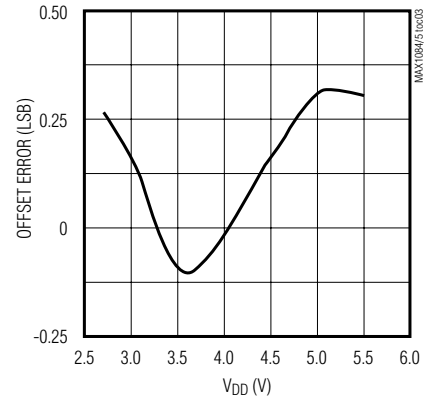

OFFSET ERROR vs. TEMPERATURE

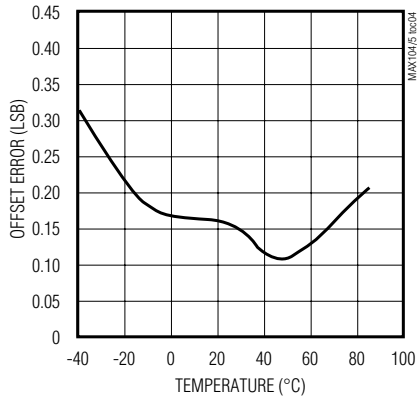

GAIN ERROR vs. SUPPLY VOLTAGE

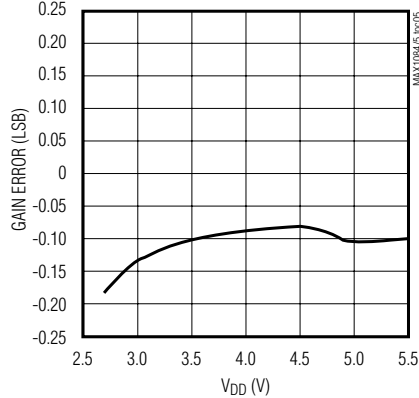

GAIN ERROR vs. TEMPERATURE

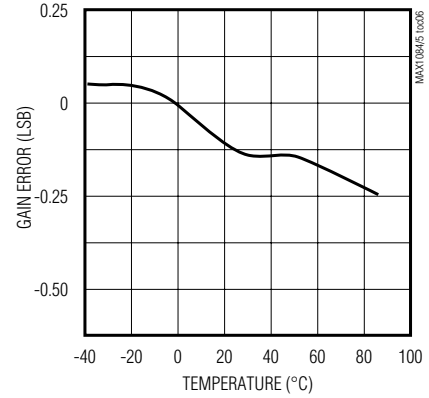

400ksp/300ksp, Single-Supply, Low-Power, Serial 10-Bit ADCs with Internal Reference

MAX1084/MAX1085

Typical Operating Characteristics (continued)

(MAX1084: $V_{DD} = +5.0V$, $f_{SCLK} = 6.4MHz$; MAX1085: $V_{DD} = +3.0V$, $f_{SCLK} = 4.8MHz$; $C_{LOAD} = 20pF$, $4.7\mu F$ capacitor at REF, $T_A = +25^\circ C$, unless otherwise noted.)

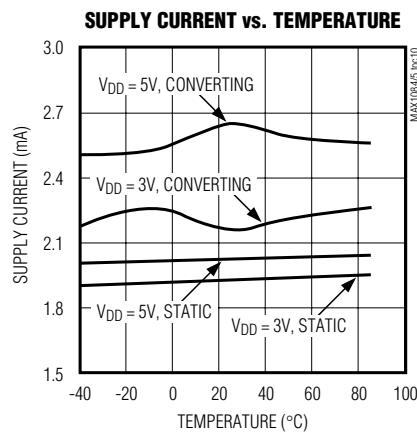
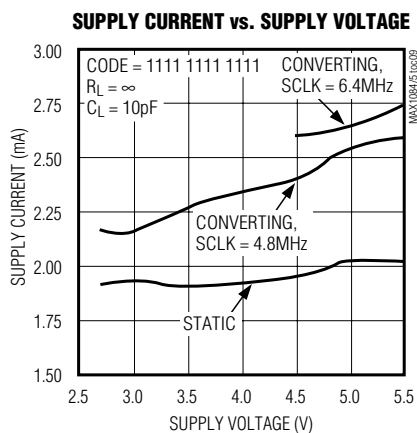
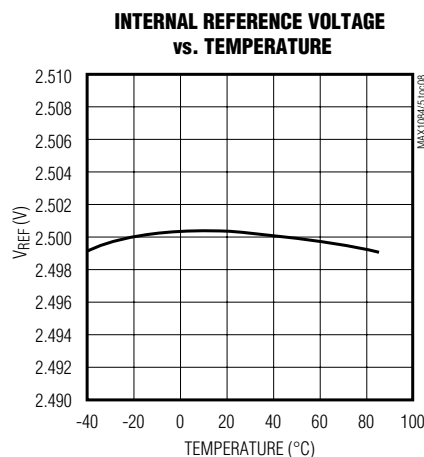
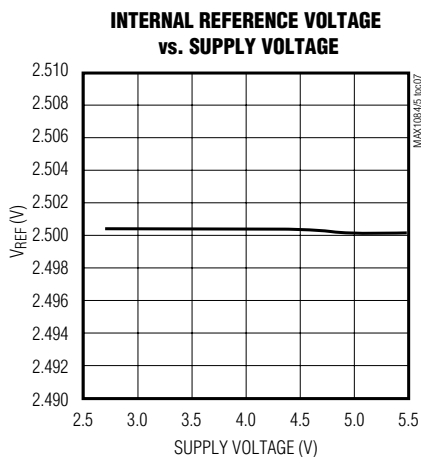

Pin Description

PIN	NAME	FUNCTION
1	V_{DD}	Positive Supply Voltage
2	AIN	Sampling Analog Input, 0 to V_{REF} Range
3	\overline{SHDN}	Active-Low Shutdown Input. Pulling \overline{SHDN} low shuts down the device and reduces the supply current to $2\mu A$ (typ).
4	REF	Reference Voltage for Analog-to-Digital Conversion. Internal 2.5V reference output. Bypass with a $4.7\mu F$ capacitor.
5	GND	Analog and Digital Ground
6	DOUT	Serial Data Output. DOUT changes state at SCLK's rising edge. High impedance when \overline{CS} is high.
7	\overline{CS}	Active-Low Chip Select. Initiates conversions on the falling edge. When \overline{CS} is high, DOUT is high impedance.
8	SCLK	Serial Clock Input. SCLK drives the conversion process and clocks data out at rates up to 6.4MHz (MAX1084) or 4.8MHz (MAX1085).

400ksp/300ksp, Single-Supply, Low-Power, Serial 10-Bit ADCs with Internal Reference

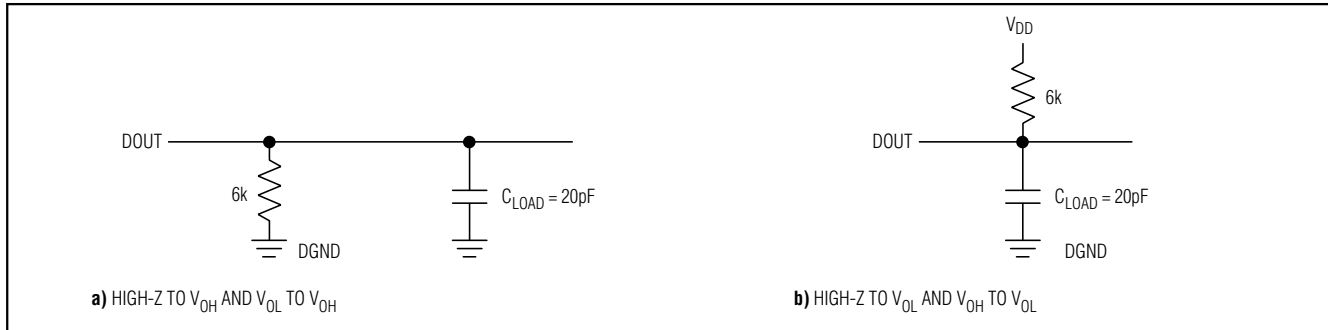

Figure 1. Load Circuits for DOUT Enable Time

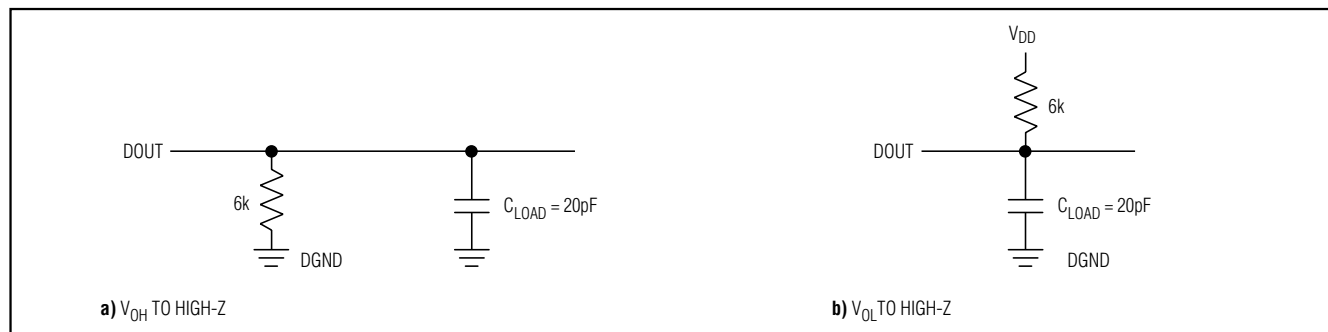

Figure 2. Load Circuits for DOUT Disable Time

Detailed Description

Converter Operation

The MAX1084/MAX1085 use an input track/hold (T/H) and successive-approximation register (SAR) circuitry to convert an analog input signal to a digital 10-bit output. Figure 3 shows the MAX1084/MAX1085 in their simplest configuration. The internal reference is trimmed to 2.5V. The serial interface requires only three digital lines (SCLK, \overline{CS} , and DOUT) and provides an easy interface to microprocessors (μ Ps).

The MAX1084/MAX1085 have two modes: normal and shutdown. Pulling \overline{SHDN} low shuts the device down and reduces supply current to 2 μ A (typ); pulling \overline{SHDN} high puts the device into operational mode. Pulling \overline{CS} low initiates a conversion that is driven by SCLK. The conversion result is available at DOUT in unipolar serial format. The serial data stream consists of three zeros, followed by the data bits (MSB first). All transitions on DOUT occur 20ns after the rising edge of SCLK. Figures 8 and 9 show the interface timing information.

Analog Input

Figure 4 shows the sampling architecture of the ADC's comparator. The full-scale input voltage is set by the internal reference ($V_{REF} = +2.5V$).

Track/Hold

In track mode, the analog signal is acquired and stored in the internal hold capacitor. In hold mode, the T/H switch opens and maintains a constant input to the ADC's SAR section.

During acquisition, the analog input AIN charges capacitor C_{HOLD} . Bringing \overline{CS} low ends the acquisition interval. At this instant, the T/H switches the input side of C_{HOLD} to GND. The retained charge on C_{HOLD} represents a sample of the input, unbalancing node ZERO at the comparator's input.

In hold mode, the capacitive digital-to-analog converter (DAC) adjusts during the remainder of the conversion cycle to restore node ZERO to 0 within the limits of 10-bit resolution. This action is equivalent to transferring a charge from C_{HOLD} to the binary-weighted capacitive

400ksp/300ksp, Single-Supply, Low-Power, Serial 10-Bit ADCs with Internal Reference

MAX1084/MAX1085

DAC, which in turn forms a digital representation of the analog input signal. At the conversion's end, the input side of C_{HOLD} switches back to AIN, and C_{HOLD} charges to the input signal again.

The time required for the T/H to acquire an input signal is a function of how quickly its input capacitance is charged. If the input signal's source impedance is high, the acquisition time lengthens, and more time must be allowed between conversions. The acquisition time, t_{ACQ} , is the maximum time the device takes to acquire the signal and the minimum time needed for the signal to be acquired. Acquisition time is calculated by:

$$t_{\text{ACQ}} = 7(R_S + R_{\text{IN}}) \times 12\text{pF}$$

where $R_{\text{IN}} = 800\Omega$, R_S = the input signal's source impedance, and t_{ACQ} is never less than 468ns (MAX1284) or 625ns (MAX1085). Source impedance below $4\text{k}\Omega$ does not significantly affect the ADC's AC performance.

Higher source impedances can be used if a $0.01\mu\text{F}$ capacitor is connected to the analog input. Note that the input capacitor forms an RC filter with the input source impedance, limiting the ADC's input signal bandwidth.

Input Bandwidth

The ADC's input tracking circuitry has a 6MHz (MAX1084) or 3MHz (MAX1085) small-signal bandwidth, so it is possible to digitize high-speed transient events and measure periodic signals with bandwidths exceeding the ADC's sampling rate by using under-sampling techniques. To avoid aliasing of unwanted high-frequency signals into the frequency band of interest, anti-alias filtering is recommended.

Analog Input Protection

Internal protection diodes, which clamp the analog input to V_{DD} and GND, allow the input to swing from $\text{GND} - 0.3\text{V}$ to $V_{\text{DD}} + 0.3\text{V}$ without damage.

If the analog input exceeds 50mV beyond the supplies, limit the input current to 2mA.

Internal Reference

The MAX1084/MAX1085 have an on-chip voltage reference trimmed to 2.5V. The internal reference output is connected to REF and also drives the internal capacitive DAC. The output can be used as a reference voltage source for other components and can source up to $800\mu\text{A}$. Bypass REF with a $4.7\mu\text{F}$ capacitor. Larger capacitors increase wake-up time when exiting shutdown (see *Using SHDN to Reduce Supply Current*). The internal reference is disabled in shutdown ($\text{SHDN} = 0$).

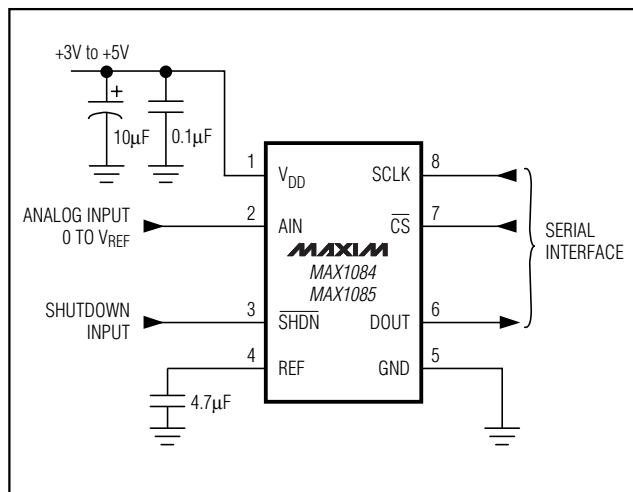

Figure 3. Typical Operating Circuit

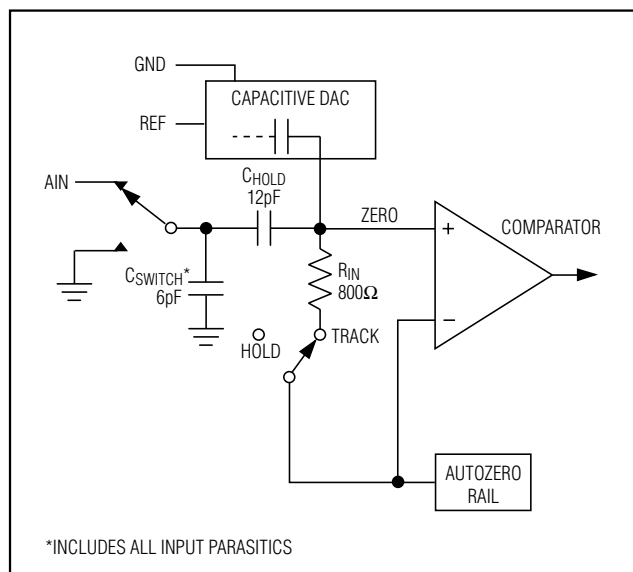

Figure 4. Equivalent Input Circuit

Serial Interface

Initialization After Power-Up and Starting a Conversion

When power is first applied, and if SHDN is not pulled low, it takes the fully discharged $4.7\mu\text{F}$ reference bypass capacitor up to 1.4ms to acquire adequate charge for specified accuracy. No conversions should be performed during this time.

400kps/300kps, Single-Supply, Low-Power, Serial 10-Bit ADCs with Internal Reference

To start a conversion, pull \overline{CS} low. At \overline{CS} 's falling edge, the T/H enters its hold mode and a conversion is initiated. Data can then be shifted out serially with the external clock.

Using \overline{SHDN} to Reduce Supply Current

Power consumption can be reduced significantly by shutting down the MAX1084/MAX1085 between conversions. Figure 6 shows a plot of average supply current vs. conversion rate. The wake-up time, t_{WAKE} , is the time from \overline{SHDN} deasserted to the time when a conversion may be initiated (Figure 5). This time depends on the time in shutdown (Figure 7) because the external 4.7 μ F reference bypass capacitor loses charge slowly during shutdown and can be as long as 1.4ms.

Timing and Control

Conversion-start and data-read operations are controlled by the \overline{CS} and SCLK digital inputs. The timing diagrams of Figures 8 and 9 outline serial-interface operation.

A \overline{CS} falling edge initiates a conversion sequence: the T/H stage holds the input voltage, the ADC begins to convert, and DOUT changes from high impedance to logic low. SCLK is used to drive the conversion process, and it shifts data out as each bit of conversion is determined.

SCLK begins shifting out the data after the rising edge of the third SCLK pulse. DOUT transitions 20ns after each SCLK rising edge. The third rising clock edge produces the MSB of the conversion at DOUT, followed by the remaining bits. Since there are 12 data bits and 3 leading zeros, at least 15 rising clock edges are

needed to shift out these bits. Extra clock pulses occurring after the conversion result has been clocked out, and prior to a rising edge of \overline{CS} , produce trailing zeros at DOUT and have no effect on converter operation.

Pull \overline{CS} high after reading the conversion's LSB. For maximum throughput, \overline{CS} can be pulled low again to initiate the next conversion immediately after the specified minimum time (t_{CS}).

Output Coding and Transfer Function

The data output from the MAX1084/MAX1085 is binary. Figure 10 depicts the nominal transfer function. Code transitions occur halfway between successive-integer LSB values; $V_{REF} = 2.5V$, and $1LSB = 2.44mV$ or $2.5V / 1024$.

Applications Information

Connection to Standard Interfaces

The MAX1084/MAX1085 serial interface is fully compatible with SPI, QSPI, and MICROWIRE (Figure 11).

If a serial interface is available, set the CPU's serial interface in master mode so the CPU generates the serial clock. Choose a clock frequency up to 6.4MHz (MAX1084) or 4.8MHz (MAX1085).

- 1) Use a general-purpose I/O line on the CPU to pull \overline{CS} low. Keep SCLK low.
- 2) Activate SCLK for a minimum of 13 clock cycles. The first two clocks produce zeros at DOUT. DOUT output data transitions 20ns after SCLK rising edge and is available in MSB-first format. Observe the SCLK-to-DOUT valid timing characteristic. Data can be clocked into the μ P on SCLK's falling or rising edge.

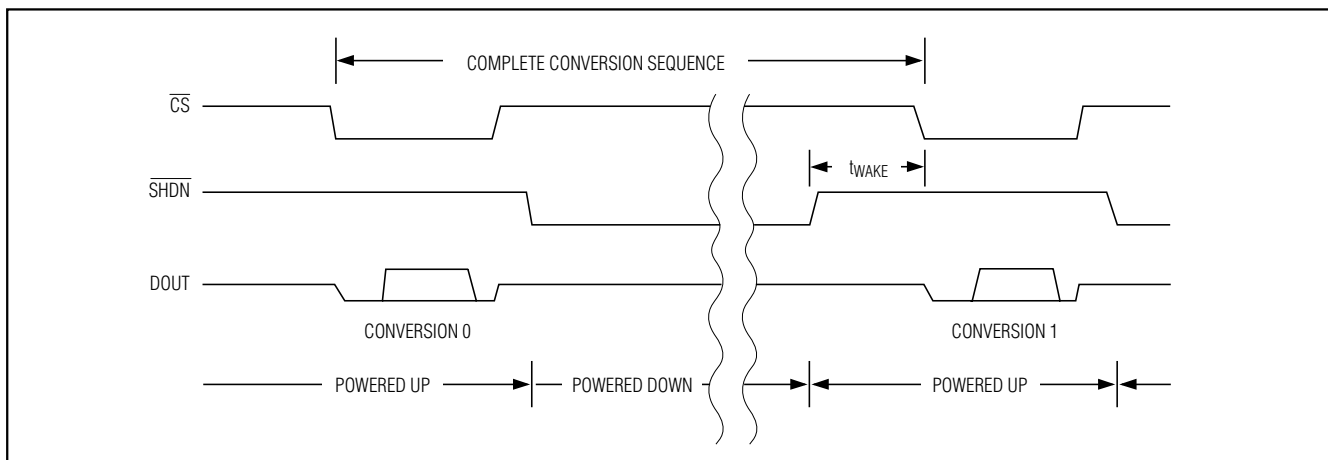

Figure 5. Shutdown Sequence

400kps/300kps, Single-Supply, Low-Power, Serial 10-Bit ADCs with Internal Reference

MAX1084/MAX1085

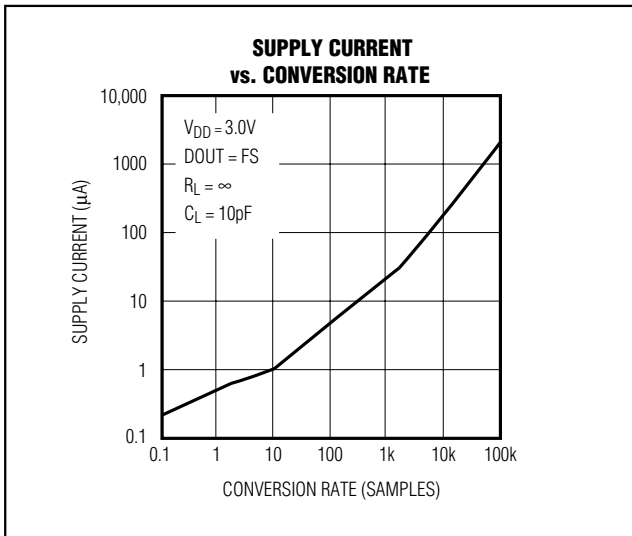

Figure 6. Supply Current vs. Conversion Rate

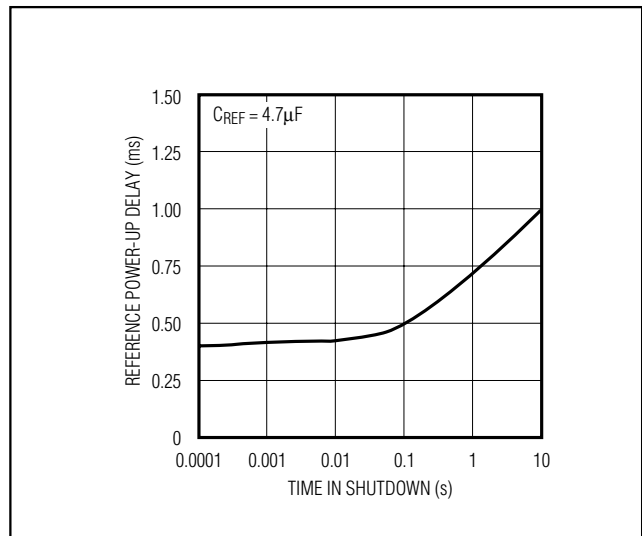

Figure 7. Reference Power-Up vs. Time in Shutdown

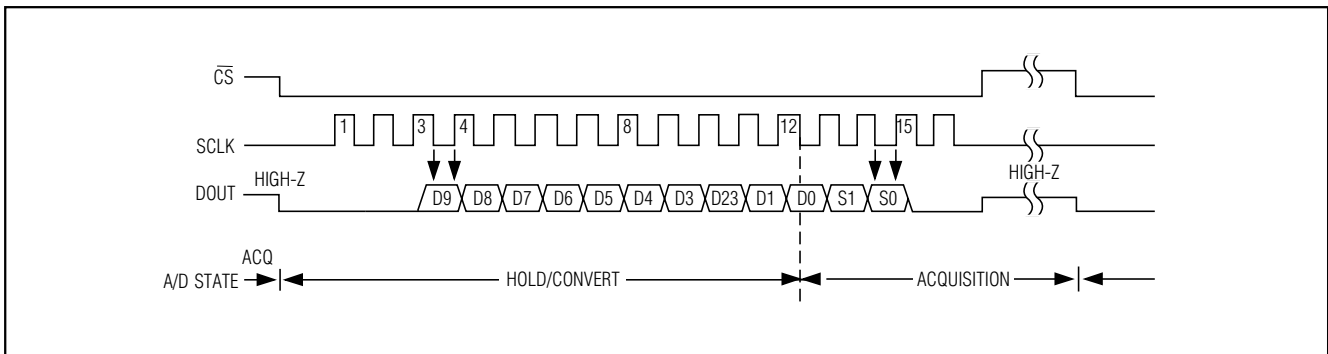

Figure 8. Interface Timing Sequence

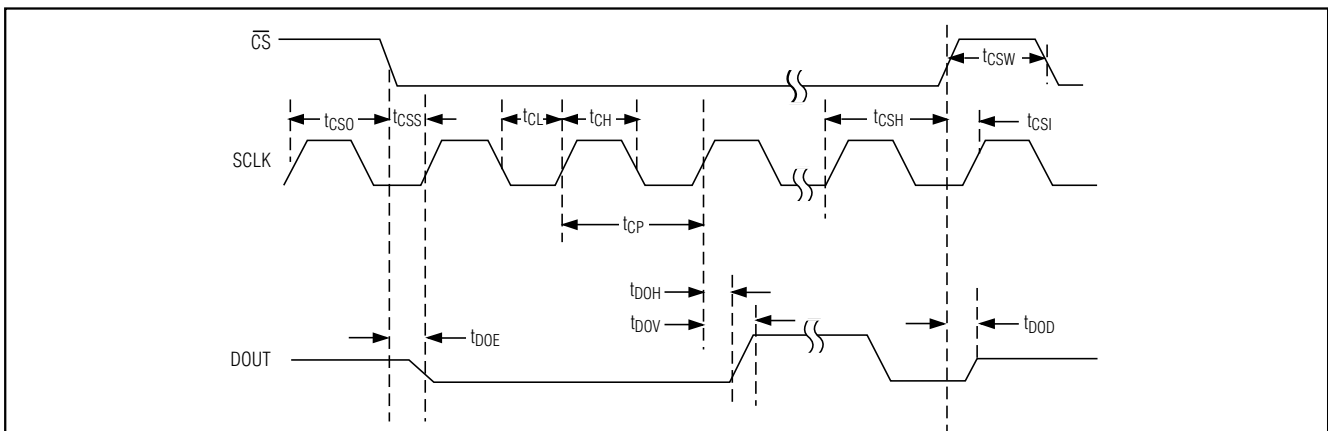

Figure 9. Detailed Serial-Interface Timing

400kps/300kps, Single-Supply, Low-Power, Serial 10-Bit ADCs with Internal Reference

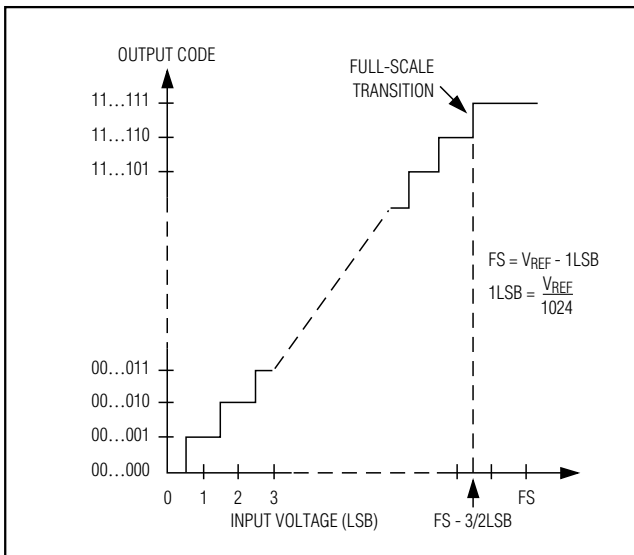

Figure 10. Unipolar Transfer Function, Full Scale (FS) = $V_{REF} - 1LSB$, Zero Scale (ZS) = GND

- 3) Pull \overline{CS} high at or after the 13th rising clock edge. If \overline{CS} remains low, the two sub-bits and trailing zeros are clocked out after the LSB.
- 4) With $\overline{CS} =$ high, wait the minimum specified time, t_{CS} , before initiating a new conversion by pulling \overline{CS} low. If a conversion is aborted by pulling \overline{CS} high before the conversion completes, wait the minimum acquisition time, t_{ACQ} , before starting a new conversion. \overline{CS} must be held low until all data bits are clocked out.

Data can be output in 2 bytes or continuously, as shown in Figure 8. The bytes contain the result of the conversion padded with three leading zeros, 2 sub-bits, and trailing zeros if SCLK is still active with \overline{CS} kept low.

SPI and Microwire

When using SPI or QSPI, set CPOL = 0 and CPHA = 0. Conversion begins with a \overline{CS} falling edge. DOUT goes low, indicating a conversion is in progress. Two consecutive 1-byte reads are required to get the full 10+2 bits from the ADC. DOUT output data transitions on SCLK's rising edge and is clocked into the μP on the following rising edge.

The first byte contains 3 leading zeros, and 5 bits of conversion result. The second byte contains the remaining 5 bits, 2 sub-bits, and 1 trailing zero. See Figure 11 for connections and Figure 12 for timing.

QSPI

Unlike SPI, which requires two 1-byte reads to acquire

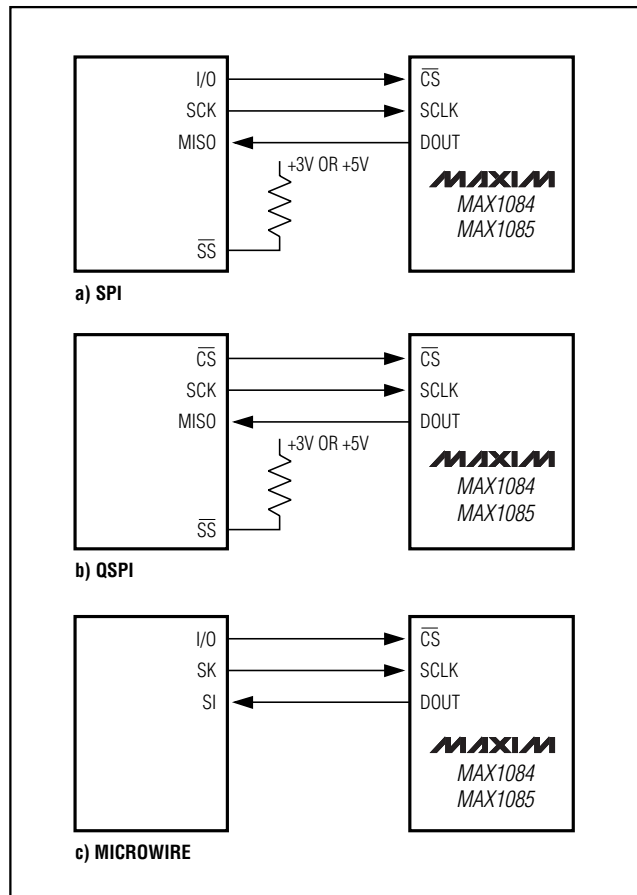

Figure 11. Common Serial-Interface Connections to the MAX1084/MAX1085

the 10 bits of data from the ADC, QSPI allows the minimum number of clock cycles necessary to clock in the data. The MAX1084/MAX1085 require 13 clock cycles from the μP to clock out the 10 bits of data. Additional clock cycles clock out the 2 sub-bits followed by trailing zeros. Figure 13 shows a transfer using CPOL = 0 and CPHA = 1. The result of conversion contains two zeros followed by the 10 bits of data in MSB-first format.

Layout and Grounding

For best performance, use PC boards. Wire-wrap boards are not recommended. Board layout should ensure that digital and analog signal lines are separated from each other. Do not run analog and digital (especially clock) lines parallel to one another, or digital lines underneath the ADC package.

Figure 14 shows the recommended system ground connections. Establish a single-point analog ground ("star"

400ksp/300ksp, Single-Supply, Low-Power, Serial 10-Bit ADCs with Internal Reference

ground point) at GND, separate from the logic ground. Connect all other analog grounds and GND to this star ground point for further noise reduction. No other digital system ground should be connected to this single-point analog ground. The ground return to the power supply for this ground should be low impedance and as short as possible for noise-free operation.

High-frequency noise in the V_{DD} power supply may affect the ADC's high-speed comparator. Bypass this supply to the single-point analog ground with 0.1 μ F and 10 μ F bypass capacitors. Minimize capacitor lead lengths for best supply-noise rejection. To reduce the effect of supply noise, a 10 Ω resistor can be connected as a lowpass filter to attenuate supply noise (Figure 14).

Definitions

Integral Nonlinearity

Integral nonlinearity (INL) is the deviation of the values on an actual transfer function from a straight line. This straight line can be either a best-straight-line fit or a line drawn between the endpoints of the transfer function, once offset and gain errors have been nullified. The

static linearity parameters for the MAX1084/MAX1085 are measured using the endpoints method.

Differential Nonlinearity

Differential nonlinearity (DNL) is the difference between an actual step width and the ideal value of 1LSB. A DNL error specification of 1LSB or less guarantees no missing codes and a monotonic transfer function.

Aperture Jitter

Aperture jitter (t_{AJ}) is the sample-to-sample variation in the time between the samples.

Aperture Delay

Aperture delay (t_{AD}) is the time defined between the falling edge of CS and the instant when an actual sample is taken.

Signal-to-Noise Ratio

For a waveform perfectly reconstructed from digital samples, signal-to-noise ratio (SNR) is the ratio of full-scale analog input (RMS value) to the RMS quantization error (residual error). The theoretical minimum analog-to-digital noise is caused by quantization error and results directly from the ADC's resolution, (N bits):

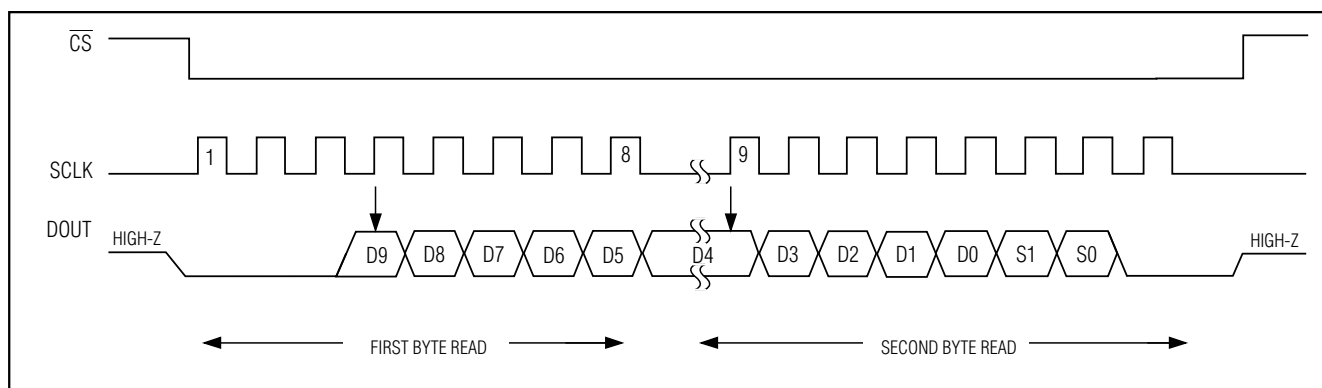

Figure 12. SPI/MICROWIRE Serial Interface Timing ($CPOL = CPHA = 0$)

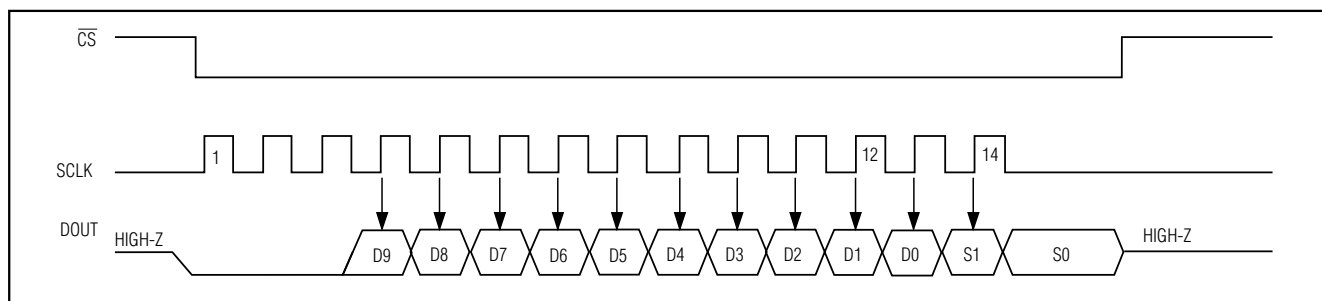

Figure 13. QSPI Serial Interface Timing ($CPOL = 0, CPHA = 1$)

400kps/300kps, Single-Supply, Low-Power, Serial 10-Bit ADCs with Internal Reference

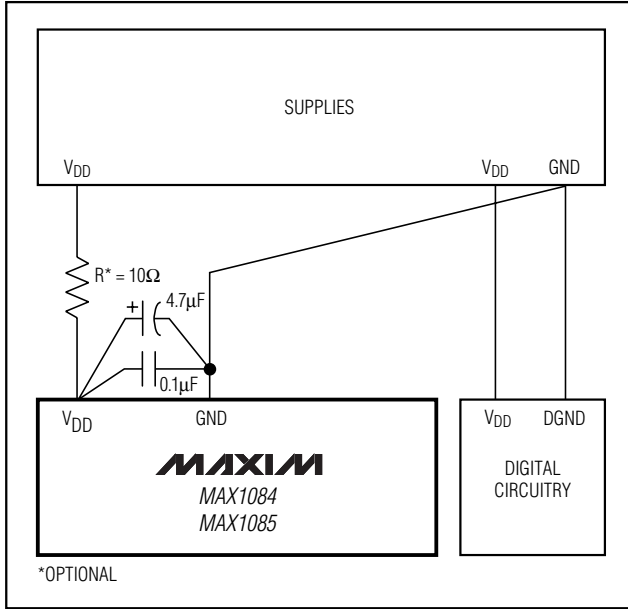

Figure 14. Power-Supply Grounding Condition

$$\text{SNR} = (6.02 \times N + 1.76)\text{dB}$$

In reality, there are other noise sources besides quantization noise, including thermal noise, reference noise, clock jitter, etc. Therefore, SNR is computed by taking the ratio of the RMS signal to the RMS noise, which includes all spectral components minus the fundamental, the first five harmonics, and the DC offset.

Signal-to-Noise Plus Distortion

Signal-to-noise plus distortion (SINAD) is the ratio of the fundamental input frequency's RMS amplitude to RMS equivalent of all other ADC output signals.

$$\text{SINAD (dB)} = 20 \times \log (\text{SignalRMS} / \text{NoiseRMS})$$

Effective Number of Bits

Effective number of bits (ENOB) indicates the global accuracy of an ADC at a specific input frequency and sampling rate. An ideal ADC's error consists of quantization noise only. With an input range equal to the full-scale range of the ADC, calculate the effective number of bits as follows:

$$\text{ENOB} = (\text{SINAD} - 1.76) / 6.02$$

Total Harmonic Distortion

Total harmonic distortion (THD) is the ratio of the RMS sum of the first five harmonics of the input signal to the fundamental itself. This is expressed as:

$$\text{THD} = 20 \times \text{LOG} \frac{\sqrt{V_2^2 + V_3^2 + V_4^2 + V_5^2}}{V_1}$$

where V1 is the fundamental amplitude, and V2 through V5 are the amplitudes of the 2nd- through 5th-order harmonics, respectively.

Spurious-Free Dynamic Range

Spurious-free dynamic range (SFDR) is the ratio of RMS amplitude of the fundamental (maximum signal component) to the RMS value of the next-largest distortion component.

Chip Information

TRANSISTOR COUNT: 4286

PROCESS: BiCMOS

400kps/300kps, Single-Supply, Low-Power, Serial 10-Bit ADCs with Internal Reference

Package Information

MAX1084/MAX1085

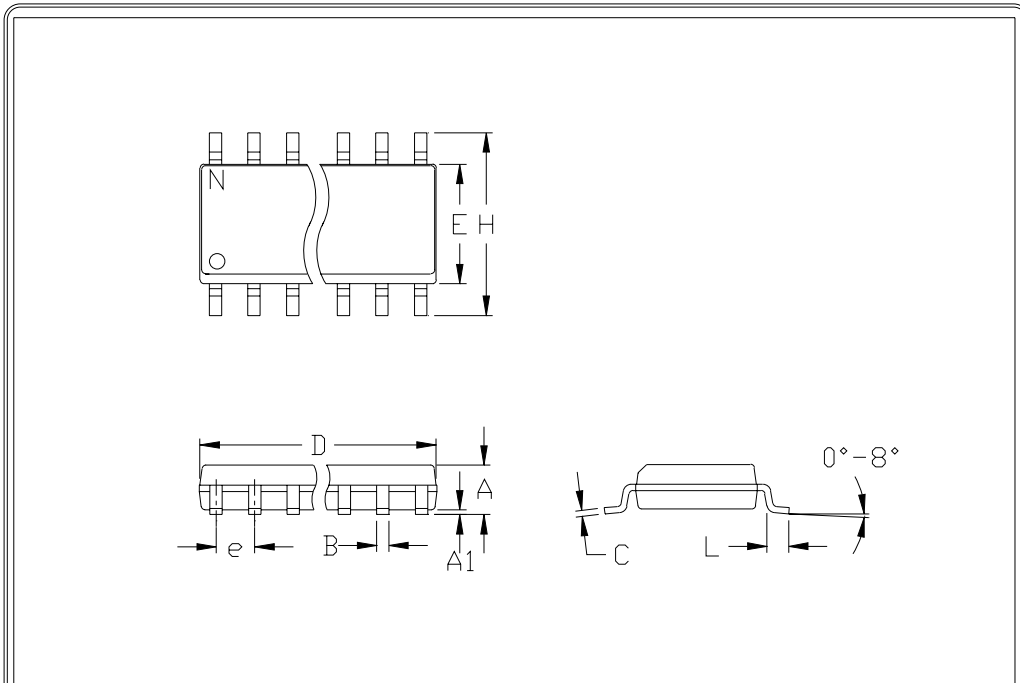

	INCHES		MILLIMETERS	
	MIN	MAX	MIN	MAX
A	0.053	0.069	1.35	1.75
A1	0.004	0.010	0.10	0.25
B	0.014	0.019	0.35	0.49
C	0.007	0.010	0.19	0.25
e	0.050		1.27	
E	0.150	0.157	3.80	4.00
H	0.228	0.244	5.80	6.20
h	0.010	0.020	0.25	0.50
L	0.016	0.050	0.40	1.27

	INCHES		MILLIMETERS		N	MS012
	MIN	MAX	MIN	MAX		
D	0.189	0.197	4.80	5.00	8	A
D	0.337	0.344	8.55	8.75	14	B
D	0.386	0.394	9.80	10.00	16	C

NOTES:

1. D&E DO NOT INCLUDE MOLD FLASH
2. MOLD FLASH OR PROTRUSIONS NOT TO EXCEED .15mm (.006")
3. LEADS TO BE COPLANAR WITHIN .102mm (.004")
4. CONTROLLING DIMENSION: MILLIMETER
5. MEETS JEDEC MS012-XX AS SHOWN IN ABOVE TABLE
6. N = NUMBER OF PINS

MAXIM
120 SAN GABRIEL DR. SAN JOSE, CA 94086 FAX (408) 737-7794
PROPRIETARY INFORMATION

PACKAGE FAMILY OUTLINE: SOIC .150" TITLE

1/1

21-0041 A
DOCUMENT CONTROL NUMBER REV

400ksps/300ksps, Single-Supply, Low-Power, Serial 10-Bit ADCs with Internal Reference

NOTES

Maxim cannot assume responsibility for use of any circuitry other than circuitry entirely embodied in a Maxim product. No circuit patent licenses are implied. Maxim reserves the right to change the circuitry and specifications without notice at any time.

16 _____ **Maxim Integrated Products, 120 San Gabriel Drive, Sunnyvale, CA 94086 408-737-7600**