

OPA452
OPA453

For most current data sheet and other product information, visit www.burr-brown.com

80V, 50mA OPERATIONAL AMPLIFIERS

FEATURES

- **WIDE POWER SUPPLY RANGE:**
±10V to ±40V
- **HIGH OUTPUT LOAD DRIVE:**
50mA Continuous
- **WIDE OUTPUT VOLTAGE SWING:** 1V to Rail
- **FULLY PROTECTED:**
Thermal Shutdown
Output Current-Limited
- **WIDE OPERATING RANGE:**
-40°C TO +125°C
- **PACKAGE OPTIONS:**
TO220-7
DDPACK-7 Surface Mount

APPLICATIONS

- PIEZOELECTRIC CELLS
- TEST EQUIPMENT
- AUDIO AMPLIFIERS
- TRANSDUCER DRIVERS
- SERVO DRIVERS

DESCRIPTION

The OPA452 and OPA453 are low cost operational amplifiers with high voltage (80V) and high current capability (50mA). The OPA452 is unity-gain stable and has a gain bandwidth product of 1.8MHz, while the OPA453 is optimized for gains greater than 5 and has an 7.5MHz bandwidth.

The OPA452 and OPA453 are internally protected against over-temperature conditions and current overloads. Power supplies in the range of ±10V to ±40V can be used. Unlike most other power op amps, the OPA452 and OPA453 have guaranteed specifications over the entire power supply range.

These laser-trimmed, monolithic integrated circuits provide excellent low-level accuracy along with wide output swing. Special design considerations assure that the product is easy to use and free from phase inversion problems often found in other amplifiers.

The OPA452 and OPA453 are available in TO220-7 and DDPACK-7 options. They are specified for junction temperature range, -40°C to +125°C.

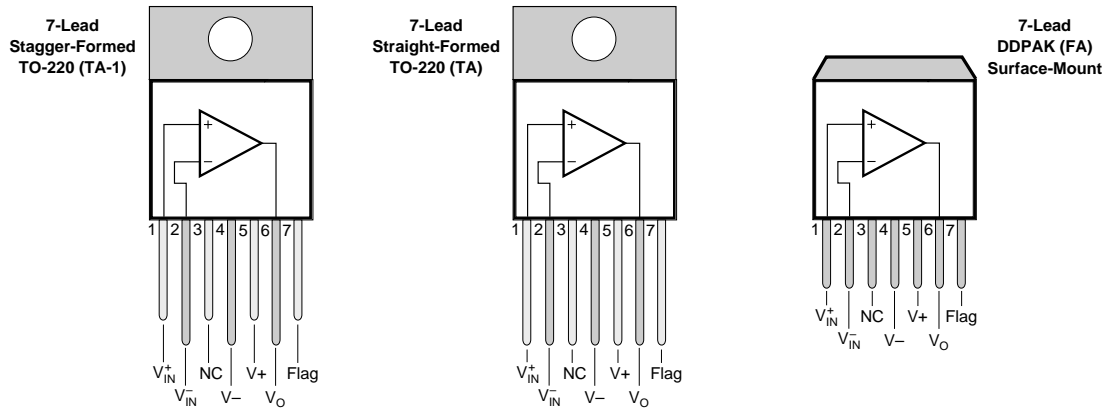

SPECIFICATIONS: $V_S = \pm 10V$ to $\pm 40V$

OPA452

Boldface limits apply over the specified junction temperature range, $T_J = -40^\circ\text{C}$ to $+125^\circ\text{C}$

At $T_J = +25^\circ\text{C}$, $R_L = 3.8\text{k}\Omega$ connected to ground and $V_{OUT} = 0V$, unless otherwise noted.

PARAMETER	CONDITION	OPA452TA, FA			UNITS	
		MIN	TYP	MAX		
OFFSET VOLTAGE Input Offset Voltage over Temperature Drift vs Power Supply over Temperature	V_{OS} dV_{OS}/dT PSRR	$V_S = \pm 40V, V_{CM} = 0V, I_O = 0V$ $V_S = \pm 10V$ to $\pm 40V, V_{CM} = 0V$		± 1 ± 5 5	± 3 ± 6 30 45	mV mV $\mu V/^\circ\text{C}$ $\mu V/V$ $\mu V/V$
INPUT BIAS CURRENT⁽¹⁾ Input Bias Current Input Offset Current	I_B I_{OS}	$V_S = \pm 40V, V_{CM} = 0V$ $V_S = \pm 40V, V_{CM} = 0V$		± 7 ± 1	± 100 ± 100	pA pA
NOISE Input Voltage Noise Density Current Noise Density	e_n i_n	$f = 1\text{kHz}$ $f = 1\text{kHz}$		21 9		$nV/\sqrt{\text{Hz}}$ $fA/\sqrt{\text{Hz}}$
INPUT VOLTAGE RANGE Common-Mode Voltage Range Common-Mode Rejection Ratio over Temperature	V_{CM} CMRR	$V_S = \pm 40V, -35V < V_{CM} < 39.5V$ $V_S = \pm 40V, -35V < V_{CM} < 39.5V$	(V-) + 5 86 76	94	(V+) - 0.5	V dB dB
INPUT IMPEDANCE Differential Common-Mode		$V_S = \pm 40V, -35V < V_{CM} < 39.5V$		$10^{13} \parallel 2$ $10^{13} \parallel 6$		$\Omega \parallel \text{pF}$ $\Omega \parallel \text{pF}$
OPEN-LOOP GAIN Open-Loop Voltage Gain over Temperature over Temperature	A_{OL}	$I_O = 10\text{mA}, -V_S+2V < V_O < +V_S-2V$ $I_O = 10\text{mA}, -V_S+2V < V_O < +V_S-2V$ $I_O = 50\text{mA}, -V_S+4V < V_O < +V_S-4V$ $I_O = 50\text{mA}, -V_S+5V < V_O < +V_S-5.5V$	105 96	110 107 110 105		dB dB dB dB
FREQUENCY RESPONSE Gain-Bandwidth Product Slew Rate Settling Time: 0.1% 0.01% Overload Recovery Time Total Harmonic Distortion + Noise	GBW SR THD+N	$V_S = \pm 40V$ $V_S = \pm 40V$ $V_S = \pm 40V, G = +1, 10V \text{ Step}, C_L = 100\text{pF}$ $V_S = \pm 40V, G = +1, 10V \text{ Step}, C_L = 100\text{pF}$ $V_{IN} \cdot \text{Gain} = V_S$ $V_S = \pm 40V, V_O = 30V_{p-p}, G = 5$ $f = 1\text{kHz}, R_L = 2\text{k}\Omega$		1.8 +7.2/-10 2 5 1 0.0008		MHz V/ μs μs μs μs %
OUTPUT Voltage Output over Temperature Voltage Output over Temperature Output Current Short-Circuit Current Capacitive Load Drive	V_{OUT} I_{SC} C_{LOAD}	$I_O = 50\text{mA}$ $I_O = 50\text{mA}$ $I_O = 10\text{mA}$ $I_O = 10\text{mA}$	(V-) + 4.0 (V-) + 5 (V-) + 2 (V-) + 2 ± 50	± 125 See Typical Curve	(V+) - 4 (V+) - 5.5 (V+) - 2 (V+) - 2	V V V V mA mA
SHUTDOWN FLAG Thermal Shutdown Status Output Normal Operation Thermally Shutdown Junction Temperature Shutdown Reset from Shutdown		$V_S = \pm 40V$ $V_S = \pm 40V$	115	0.1 140 +160 +145	1.0	μA μA $^\circ\text{C}$ $^\circ\text{C}$
POWER SUPPLY Supply Voltage Range Quiescent Current (per amplifier) over Temperature	V_S I_Q	$I_O = 0$	± 10	± 5.5	± 40 ± 6.5 ± 7.5	V mA mA
TEMPERATURE RANGE Specified Range (junction) Operating Range (junction) Storage Range (ambient) Thermal Resistance TO200-7 DDPAK-7	T_J θ_{JC}		-40 -55 -65		+125 +125 +150	$^\circ\text{C}$ $^\circ\text{C}$ $^\circ\text{C}$ $^\circ\text{C}/\text{W}$ $^\circ\text{C}/\text{W}$

NOTES: (1) All tests are high-speed tested at $+25^\circ\text{C}$ ambient temperature. Effective junction temperature is $+25^\circ\text{C}$ unless otherwise noted.

SPECIFICATIONS: $V_S = \pm 10V$ to $\pm 40V$

OPA453

Boldface limits apply over the specified junction temperature range, $T_J = -40^\circ\text{C}$ to $+125^\circ\text{C}$

At $T_J = +25^\circ\text{C}$, $R_L = 3.8\text{k}\Omega$ connected to ground and $V_{OUT} = 0V$, unless otherwise noted.

PARAMETER	CONDITION	OPA453TA, FA			UNITS
		MIN	TYP	MAX	
OFFSET VOLTAGE Input Offset Voltage over Temperature Drift vs Power Supply over Temperature	V_{OS} dV_{OS}/dT PSRR $V_S = \pm 10V$ to $\pm 40V$, $V_{CM} = 0V$	$V_S = \pm 40V$, $V_{CM} = 0V$, $I_O = 0V$	± 1	± 3 ± 6	mV mV $\mu V/^\circ\text{C}$ $\mu V/V$ $\mu V/V$
INPUT BIAS CURRENT⁽¹⁾ Input Bias Current Input Offset Current	I_B I_{OS}	$V_S = \pm 40V$, $V_{CM} = 0V$ $V_S = \pm 40V$, $V_{CM} = 0V$	± 7 ± 1	± 100 ± 100	pA pA
NOISE Input Voltage Noise Density Current Noise Density	e_n i_n	$f = 1\text{kHz}$ $f = 1\text{kHz}$	21 9		$\text{nV}/\sqrt{\text{Hz}}$ $\text{fA}/\sqrt{\text{Hz}}$
INPUT VOLTAGE RANGE Common-Mode Voltage Range Common-Mode Rejection Ratio over Temperature	V_{CM} CMRR	$V_S = \pm 40V$, $-35V < V_{CM} < 39.5V$ $V_S = \pm 40V$, $-35V < V_{CM} < 39.5V$	(V-) + 5 86 76	94	(V+) - 0.5 V dB dB
INPUT IMPEDANCE Differential Common-Mode		$V_S = \pm 40V$, $-35V < V_{CM} < 39.5V$		$10^{13} \parallel 2$ $10^{13} \parallel 6$	$\Omega \parallel \text{pF}$ $\Omega \parallel \text{pF}$
OPEN-LOOP GAIN Open-Loop Voltage Gain over Temperature over Temperature	A_{OL}	$I_O = 10\text{mA}$, $-V_S+2V < V_O < +V_S-2V$ $I_O = 10\text{mA}$, $-V_S+2V < V_O < +V_S-2V$ $I_O = 50\text{mA}$, $-V_S+4V < V_O < +V_S-4V$ $I_O = 50\text{mA}$, $-V_S+5V < V_O < +V_S-5.5V$	105 96	110 107 110 105	dB dB dB dB
FREQUENCY RESPONSE Gain-Bandwidth Product Slew Rate Settling Time: 0.1% 0.01% Overload Recovery Time Total Harmonic Distortion + Noise	GBW SR THD+N	$V_S = \pm 40V$ $V_S = \pm 40V$ $V_S = \pm 40V$, $G = +5$, 10V Step, $C_L = 100\text{pF}$ $V_S = \pm 40V$, $G = +5$, 10V Step, $C_L = 100\text{pF}$ $V_{IN} \cdot \text{Gain} = V_S$ $V_S = \pm 40V$, $V_O = 30\text{Vp-p}$, $G = 5$ $f = 1\text{kHz}$, $R_L = 2\text{k}\Omega$		7.5 $+23/-38$ 1 1.5 1 0.0008	MHz V/ μs μs μs μs %
OUTPUT Voltage Output over Temperature Voltage Output over Temperature Output Current Short-Circuit Current Capacitive Load Drive	V_{OUT} I_{SC} C_{LOAD}	$I_O = 50\text{mA}$ $I_O = 50\text{mA}$ $I_O = 10\text{mA}$ $I_O = 10\text{mA}$	(V-) + 4.0 (V-) + 5 (V-) + 2 (V-) + 2 ± 50	± 125 See Typical Curve	(V+) - 4 (V+) - 5.5 (V+) - 2 (V+) - 2 mA mA
SHUTDOWN FLAG Thermal Shutdown Status Output Normal Operation Thermally Shutdown Junction Temperature Shutdown Reset from Shutdown		$V_S = \pm 40V$ $V_S = \pm 40V$	115	0.1 140 160 145	μA μA $^\circ\text{C}$ $^\circ\text{C}$
POWER SUPPLY Supply Voltage Range Quiescent Current (per amplifier) over Temperature	V_S I_Q	$I_O = 0$	± 10	± 5.5 ± 6.5 ± 7.5	V mA mA
TEMPERATURE RANGE Specified Range (junction) Operating Range (junction) Storage Range (ambient) Thermal Resistance TO200-7 DDPAK-7	T_J θ_{JC}		-40 -55 -65		$^\circ\text{C}$ $^\circ\text{C}$ $^\circ\text{C}$ $^\circ\text{C}/\text{W}$ $^\circ\text{C}/\text{W}$

NOTES: (1) All tests are high-speed tested at $+25^\circ\text{C}$ ambient temperature. Effective junction temperature is $+25^\circ\text{C}$ unless otherwise noted.

ABSOLUTE MAXIMUM RATINGS⁽¹⁾

Supply Voltage, V+ to V-	80V
Signal Input Terminals, Voltage ⁽²⁾	(V-) - 0.5V to (V+) + 0.5V
Current ⁽²⁾	5mA
Output Short-Circuit	Continuous
Operating Temperature	-55°C to +125°C
Storage Temperature	-65°C to +150°C
Junction Temperature	+150°C
Lead Temperature (soldering 10s, TO-220)	300°C
(soldering 3s, DDPAK)	240°C

NOTE: (1) Stresses above these ratings may cause permanent damage. Exposure to absolute maximum conditions for extended periods may degrade device reliability. (2) Input terminals are diode-clamped to the power supply rails. Input signals that can swing more than 0.5V beyond the supply rails should be current limited to 5mA or less.



ELECTROSTATIC DISCHARGE SENSITIVITY

This integrated circuit can be damaged by ESD. Burr-Brown recommends that all integrated circuits be handled with appropriate precautions. Failure to observe proper handling and installation procedures can cause damage.

ESD damage can range from subtle performance degradation to complete device failure. Precision integrated circuits may be more susceptible to damage because very small parametric changes could cause the device not to meet its published specifications.

PACKAGE/ORDERING INFORMATION

PRODUCT	PACKAGE	PACKAGE DRAWING NUMBER	SPECIFIED TEMPERATURE RANGE	PACKAGE MARKING	ORDERING NUMBER ⁽¹⁾	TRANSPORT MEDIA
OPA452TA	TO220-7 (straight leads)	336	-40°C to +125°C	OPA452T	OPA452TA	Rails
OPA452TA-1	TO220-7 ZIP	327	"	"	OPA452TA-1	Rails
OPA452FA	DDPAK-7	328	-40°C to +125°C	OPA452F	OPA452FA	Rails
"	"	"	"	"	OPA452FA/500	Tape and Reel
OPA453TA	TO220-7 (straight leads)	336	-40°C to +125°C	OPA453T	OPA453TA	Rails
OPA453TA-1	TO220-7 ZIP	327	"	"	OPA453TA-1	Rails
OPA453FA	DDPAK-7	328	-40°C to +125°C	OPA453F	OPA453FA	Rails
"	"	"	"	"	OPA453FA/500	Tape and Reel

NOTES: (1) Products followed by a slash (/) are only available in Tape and Reel in the quantities indicated (e.g., /500 indicates 500 devices per reel). Ordering 500 pieces of "OPA452FA/500" will get a single 500-piece Tape and Reel.

The information provided herein is believed to be reliable; however, BURR-BROWN assumes no responsibility for inaccuracies or omissions. BURR-BROWN assumes no responsibility for the use of this information, and all use of such information shall be entirely at the user's own risk. Prices and specifications are subject to change without notice. No patent rights or licenses to any of the circuits described herein are implied or granted to any third party. BURR-BROWN does not authorize or warrant any BURR-BROWN product for use in life support devices and/or systems.

TYPICAL PERFORMANCE CURVES

At $T_J = +25^\circ\text{C}$, $V_S = \pm 40\text{V}$ and $R_L = 3.8\text{k}\Omega$, unless otherwise noted.

All temperatures are junction temperatures unless otherwise noted. Refer to the Applications Information section to calculate junction temperatures from ambient temperatures for a specific configuration.

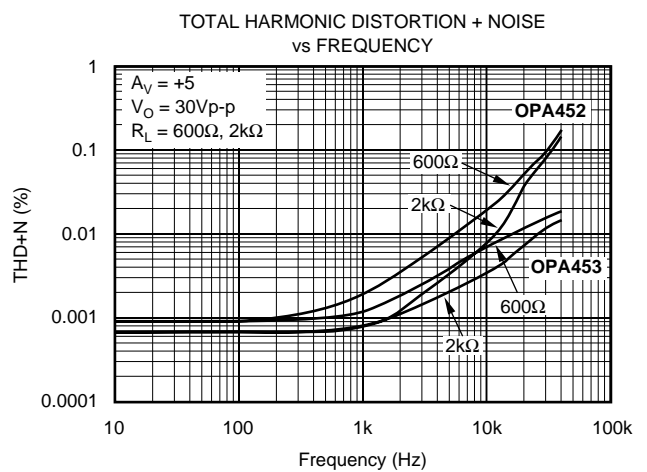
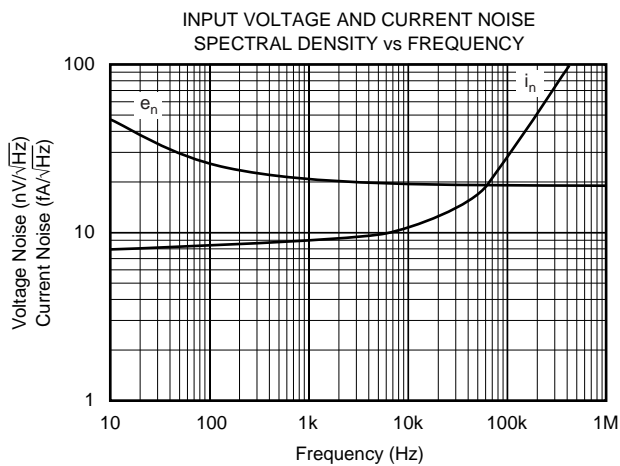
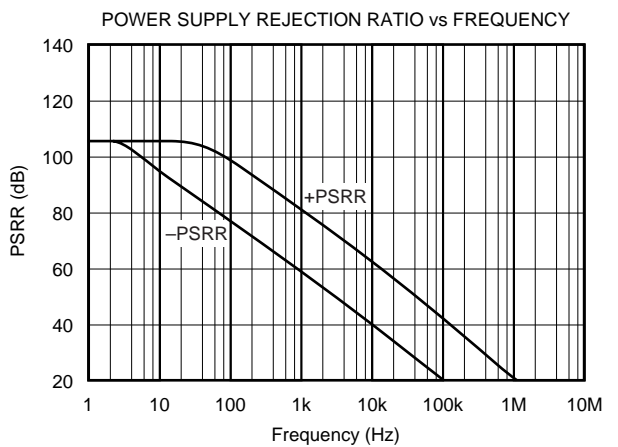
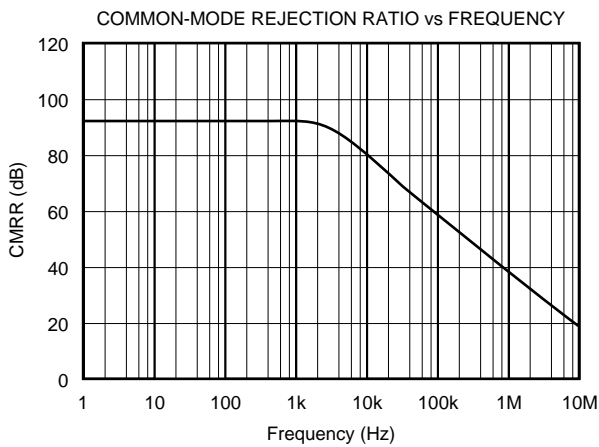
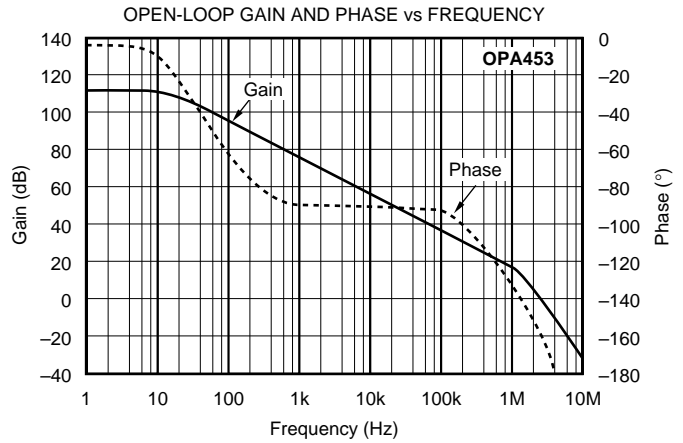
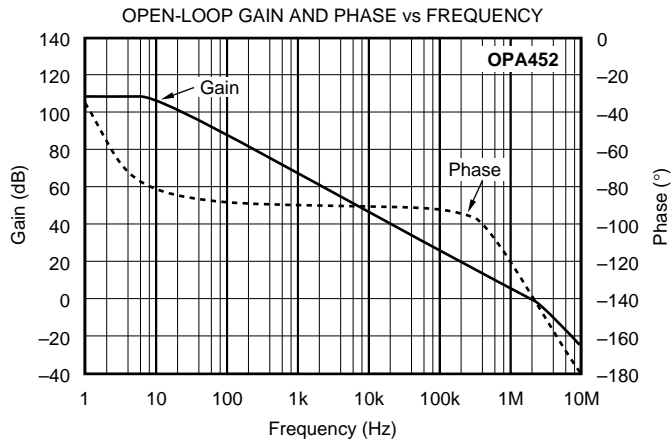

TYPICAL PERFORMANCE CURVES (Cont.)

At $T_J = +25^\circ\text{C}$, $V_S = \pm 40\text{V}$ and $R_L = 3.8\text{k}\Omega$, unless otherwise noted.

All temperatures are junction temperatures unless otherwise noted. Refer to the Applications Information section to calculate junction temperatures from ambient temperatures for a specific configuration.

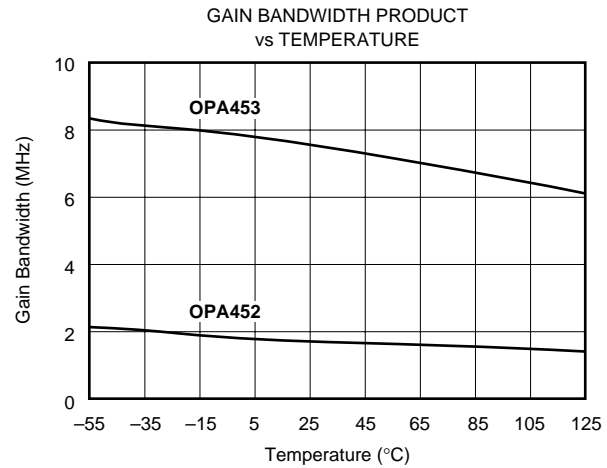
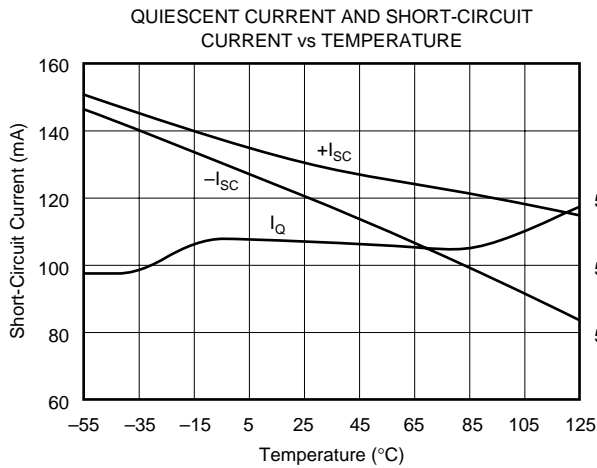
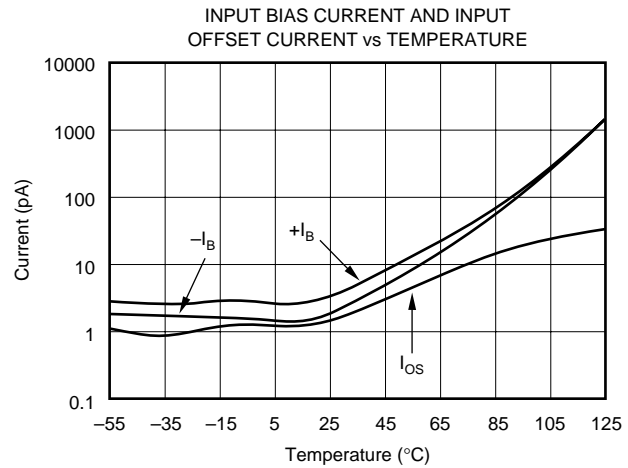
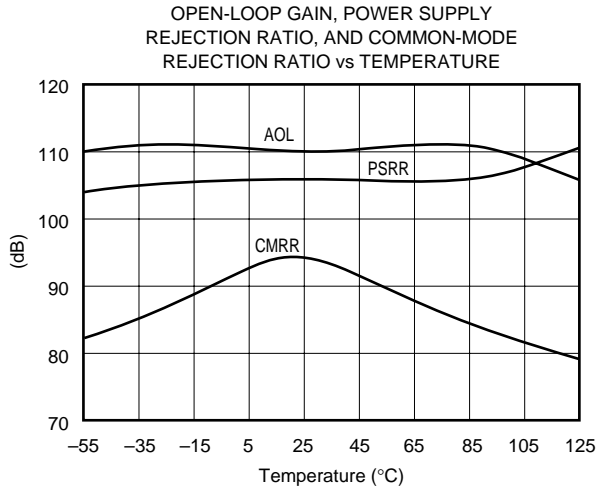
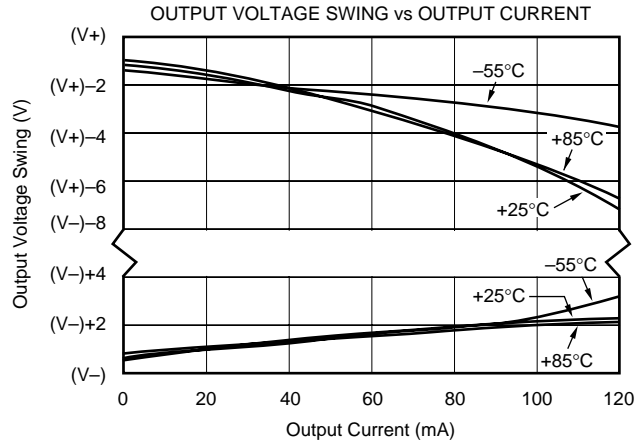
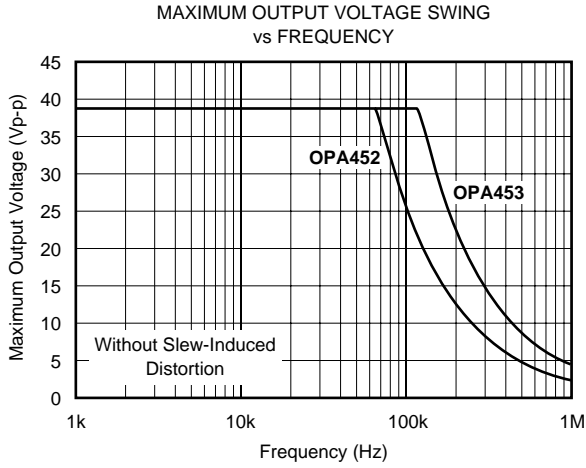

TYPICAL PERFORMANCE CURVES (Cont.)

At $T_J = +25^\circ\text{C}$, $V_S = \pm 40\text{V}$ and $R_L = 3.8\text{k}\Omega$, unless otherwise noted.

All temperatures are junction temperatures unless otherwise noted. Refer to the Applications Information section to calculate junction temperatures from ambient temperatures for a specific configuration.

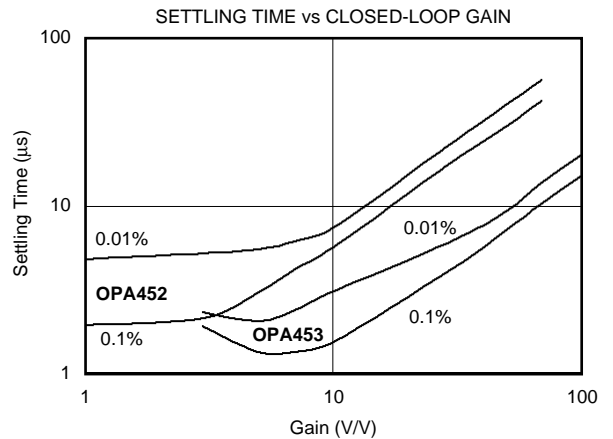
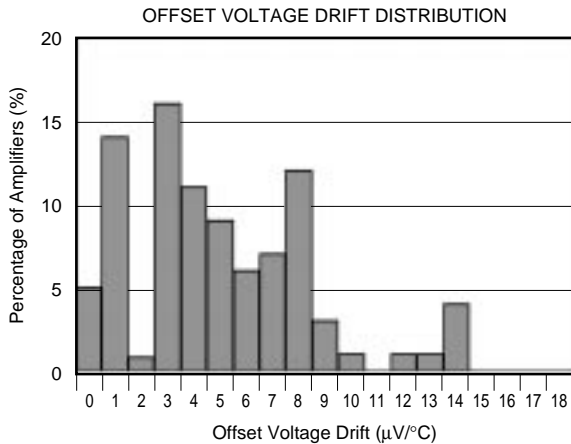
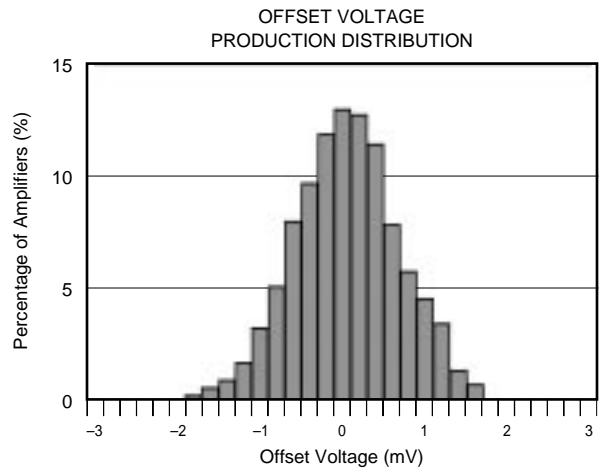
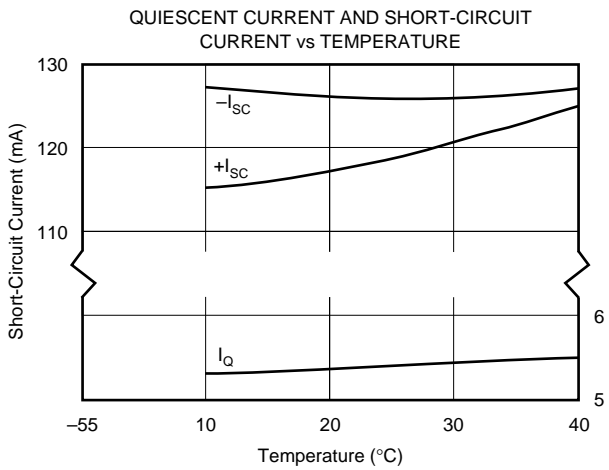
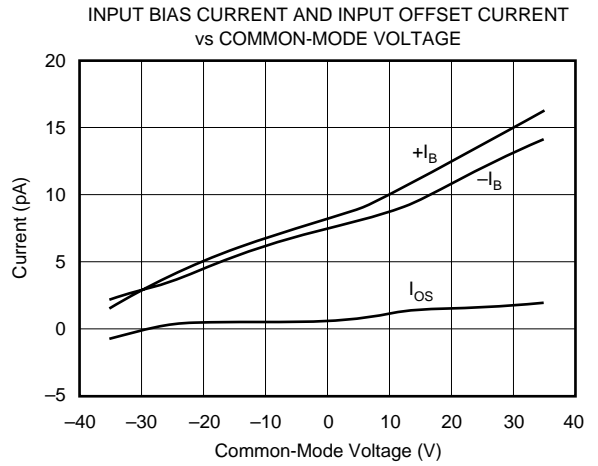
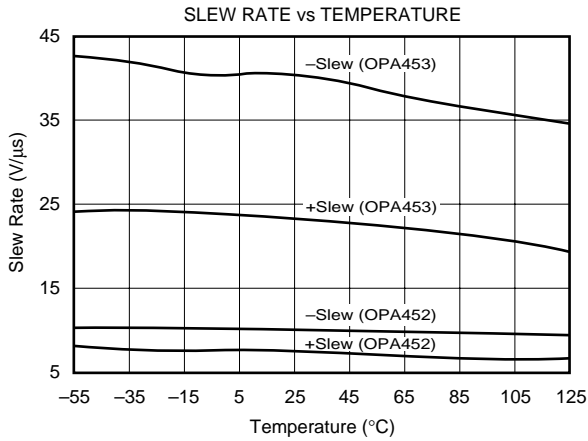

TYPICAL PERFORMANCE CURVES (Cont.)

At $T_J = +25^\circ\text{C}$, $V_S = \pm 40\text{V}$ and $R_L = 3.8\Omega$, unless otherwise noted.

All temperatures are junction temperatures unless otherwise noted. Refer to the Applications Information section to calculate junction temperatures from ambient temperatures for a specific configuration.

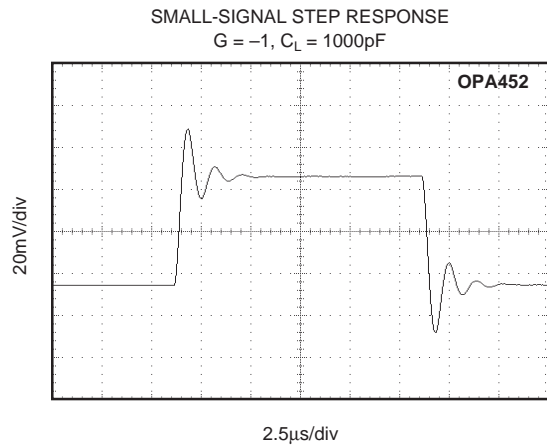
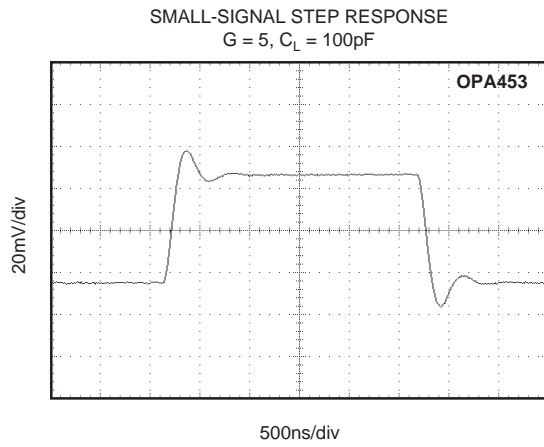
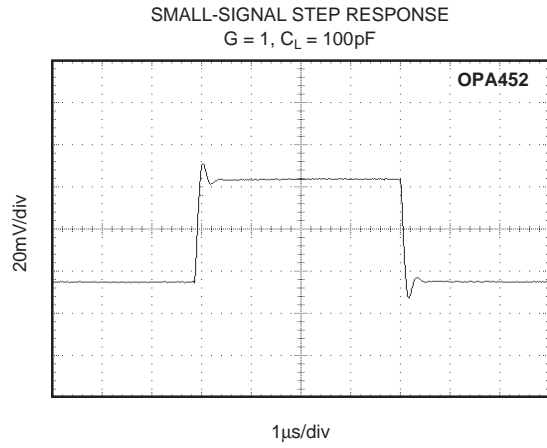
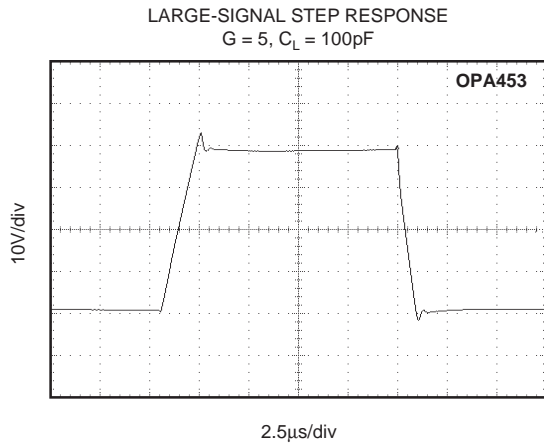
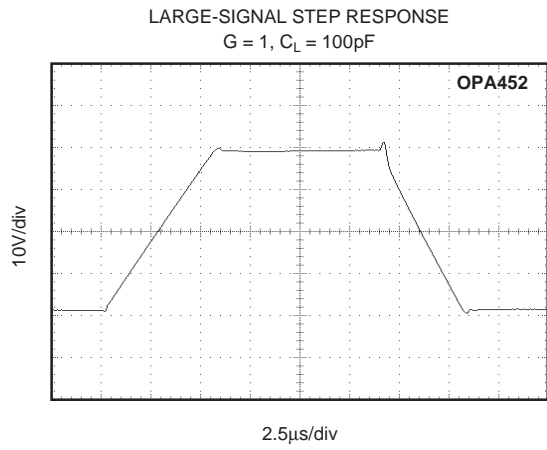
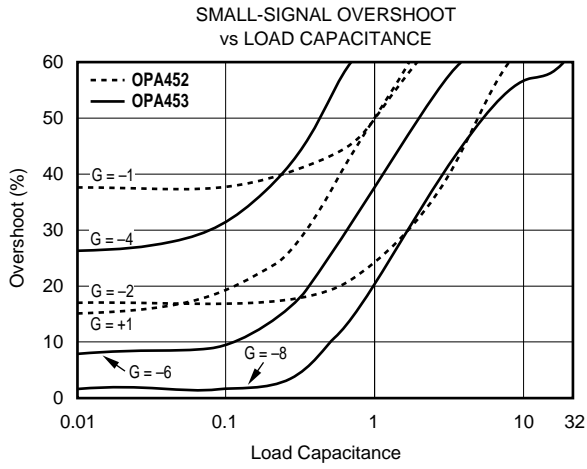

APPLICATIONS INFORMATION

Figure 1 shows the OPA452 connected as a basic non-inverting amplifier. The OPA452 can be used in virtually any op amp configuration. OPA453 is designed for use in configurations with gains of 5 or greater. Power supply terminals should be bypassed with 0.1µF capacitors, or greater, near the power supply pins. Be sure that the capacitors are appropriately rated for the power supply voltage used. The OPA452 and OPA453 can supply output currents up to 50mA with excellent performance.

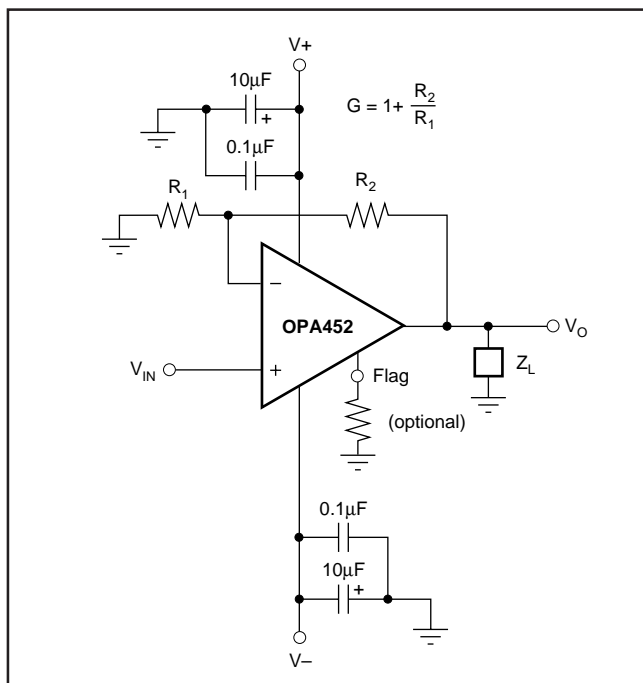

FIGURE 1. Basic Circuit Connections.

CURRENT LIMIT

The OPA452 and OPA453 are designed with internal current-limiting circuitry that limits the output current to approximately 125mA. The current limit varies slightly with increasing junction temperature and supply voltage as shown in the typical curves. Current Limit in combination with the thermal protection circuitry, provides protection from most types of overload conditions including short circuit to ground.

THERMAL PROTECTION

The OPA452 and OPA453 have thermal shutdown circuitry that protects the amplifier from damage caused by overload conditions. The thermal protection circuitry disables the output when the junction temperature reaches approximately 160°C, allowing the device to cool. When the junction temperature cools to approximately 140°C, the output circuitry is automatically re-enabled.

The thermal shutdown function is not intended to replace proper heat sinking. Activation of the thermal shutdown circuitry is an indication of excessive power dissipation or an inadequate heat sink. Continuously running the amplifier into thermal shutdown can degrade reliability.

The Thermal Shutdown Indicator (“flag”) pin can be monitored to determine if shutdown is occurring. During normal operation, the current output from the flag pin is typically 50nA. During shutdown, the current output from the flag pin increases to 140µA (typical). This current output allows for easy interfacing to external logic. See Figure 2 for two examples implementing this function.

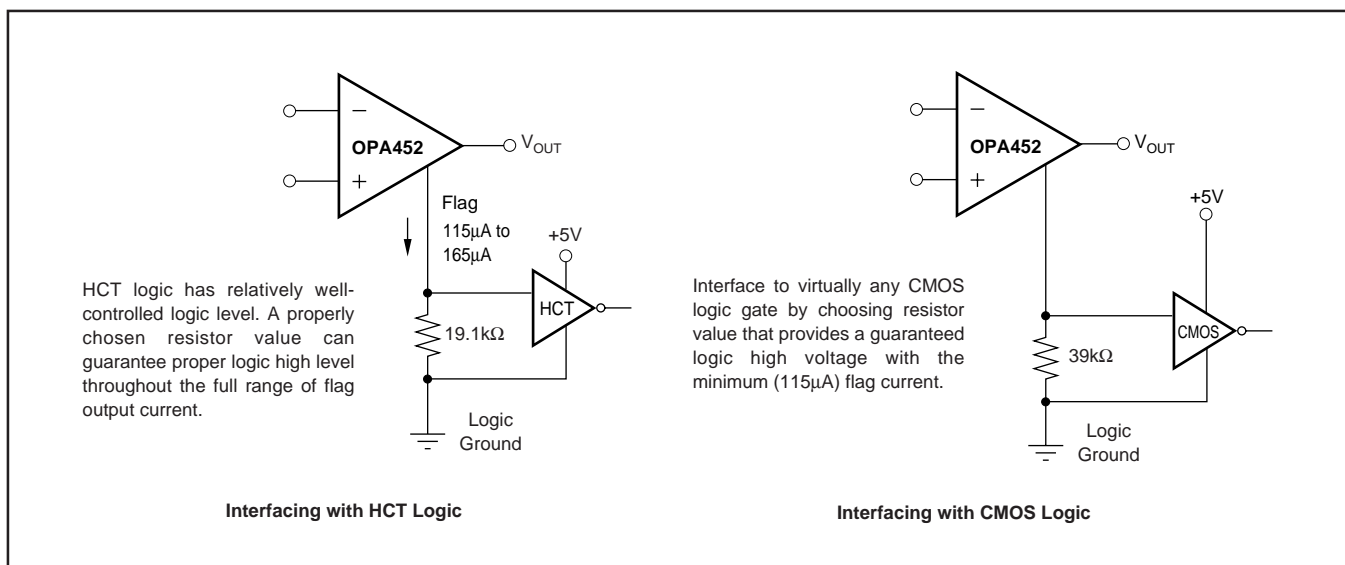

FIGURE 2. Thermal Shutdown Indicator.

POWER SUPPLIES

The OPA452 and OPA453 may be operated from power supplies of $\pm 10V$ to $\pm 40V$, or a total of 80V with excellent performance. Most behavior remains unchanged throughout the full operating voltage range. Parameters that vary significantly with operating voltage are shown in the Typical Performance Curves.

For applications that do not require symmetrical output voltage swing, power supply voltages do not need to be equal. The OPA452 and OPA453 can operate with as little as 20V between the supplies or with up to 80V between the supplies. For example, the positive supply could be set to 70V with the negative supply at $-10V$ or vice-versa.

The tabs of the DDPAK-7 and TO220 packages are electrically connected to the negative supply (V_-), however, these connections should not be used to carry current. For best thermal performance, the tab should be soldered directly to the circuit board copper area (see heat sink text).

POWER DISSIPATION

Internal power dissipation of these op amps can be quite large. All of the specifications for the OPA452 and OPA453 may change with junction temperature. If the device is not subjected to internal self-heating, the junction temperature will be the same as the ambient. However, in practical applications, the device will self-heat and the junction temperature will be significantly higher than ambient. The following calculation can be performed to establish junction temperature as a function of ambient temperature and the conditions of the application.

Consider the OPA452 in a circuit configuration where the load is 600Ω and the output voltage is 20V. The supplies are at $\pm 40V$ and the ambient temperature (T_A) is $40^\circ C$. The θ_{JA} for the package plus heat sink is $30^\circ C/W$.

First, the quiescent heating of the op amp is as follows:

$$P_{D(\text{internal})} = I_Q \cdot V_S = 6\text{mA} \cdot 80V = 480\text{mW}$$

The output current (I_O) can be calculated:

$$I_O = V_O / R_L = 20V / 600\Omega = 33.33\text{mA}$$

The power being dissipated (P_D) in the output transistor of the amplifier can be calculated:

$$P_{D(\text{output stage})} = I_O \cdot (V_S - V_O) = 33.3\text{mA} \cdot (40 - 20) = 667\text{mW}$$

$$P_{D(\text{total})} = P_{D(\text{internal})} + P_{D(\text{output stage})} = 480\text{mW} + 667\text{mW} = 1147\text{mW}$$

The resulting junction temperature can be calculated:

$$T_J = T_A + P_D \theta_{JA}$$

$$T_J = 40^\circ C + 1147\text{mW} \cdot 30^\circ C/W = 74.4^\circ C$$

Where,

V_O = output voltage

V_S = supply voltage

I_O = output current

R_L = load resistance

T_J = junction temperature ($^\circ C$)

T_A = ambient temperature ($^\circ C$)

θ_{JA} = junction-to-air thermal resistance ($^\circ C/W$)

To estimate the margin of safety in a complete design (including heat sink), increase the ambient temperature until the thermal protection is activated. Use worst-case load and signal conditions. For good reliability, the thermal protection should trigger more than $+35^\circ C$ above the maximum expected ambient condition of your application. This ensures a maximum junction temperature of $+125^\circ C$ at the maximum expected ambient condition.

Operation from a single power supply (or unbalanced power supplies) can produce even larger power dissipation since a larger voltage can be impressed across the conducting output transistor. Consult Application Bulletin AB-039 for further information on how to calculate or measure power dissipation.

Power dissipation can be minimized by using the lowest possible supply voltage. For example, with a 50mA load, the output will swing to within 5.0V of the power supply rails. Power supplies set to no more than 5.0V above the maximum output voltage swing required by the application will minimize the power dissipation.

SAFE OPERATING AREA

The Safe Operating Area (SOA curves, Figure 3) shows the permissible range of voltage and current. The safe output current decreases as the voltage across the output transistor ($V_S - V_O$) increases. For further insight on SOA, consult Application Bulletin AB-039.

Output short circuits are a very demanding case for SOA. A short circuit to ground forces the full power supply voltage (V_+ or V_-) across the conducting transistor and produces a

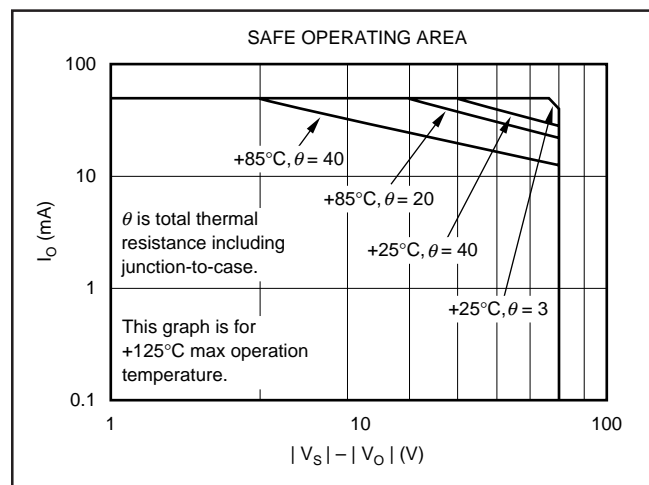

FIGURE 3. DDPAK-7 and TO220-7 Safe Operating Area.

typical output current of 125mA. With $\pm 40V$ power supplies, this creates an internal dissipation of 10W. This far exceeds practical heatsinking is not recommended. If operation in this region is unavoidable, use the part with a heat sink.

HEAT SINKING

Power dissipated in the OPA452 or OPA453 will cause the junction temperature to rise. For reliable operation, the junction temperature should be limited to $+125^{\circ}C$. Many applications will require a heat sink to assure that the maximum operating junction temperature is not exceeded. The heat sink required depends on the power dissipated and on ambient conditions.

For heat sinking purposes, the tab of the DDPACK is typically soldered directly to a circuit board copper area. Increasing the copper area improves heat dissipation. Figure 4 shows typical thermal resistance from junction-to-ambient as a function of copper area.

Depending on conditions, additional heat sinking may be required. Aavid Thermal Products Inc. manufactures surface-mountable heat sinks designed specifically for use with these packages. Further information is available on Aavid's web site, www.aavid.com.

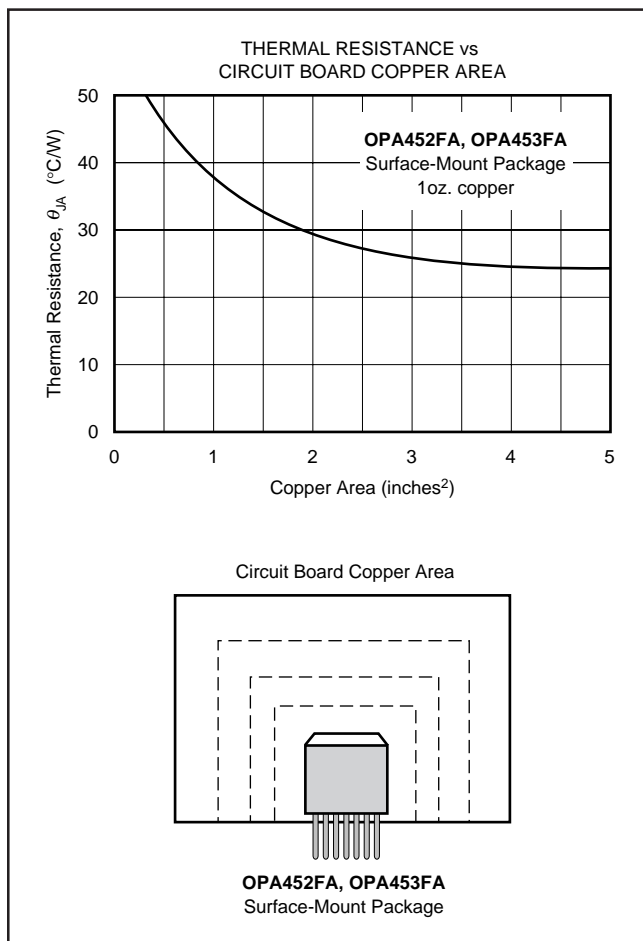

FIGURE 4. DDPACK Thermal Resistance vs Circuit Board Copper Area.

CAPACITIVE LOADS

The dynamic characteristics of the OPA452 and OPA453 have been optimized for commonly encountered gains, loads, and operating conditions. The combination of low closed-loop gain and capacitive load will decrease the phase margin and may lead to gain peaking or oscillations. Figure 5 shows a circuit that preserves phase margin with capacitive load. Figure 6 shows the small-signal step response for the circuit in Figure 5. Consult Application Bulletin AB-028 for more information.

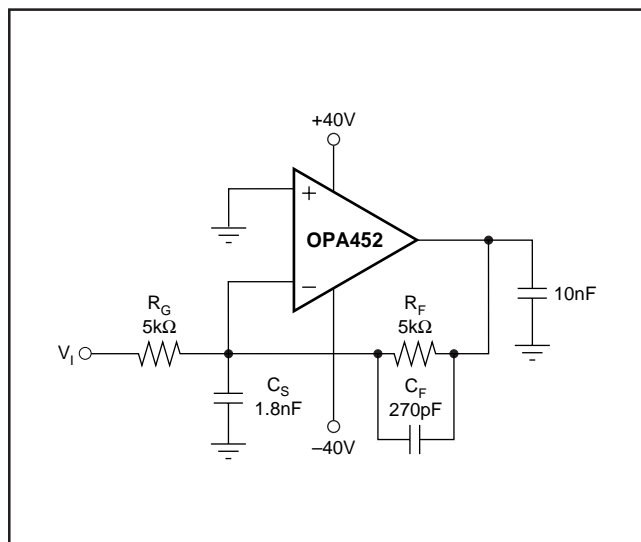

FIGURE 5. Driving Large Capacitive Loads.

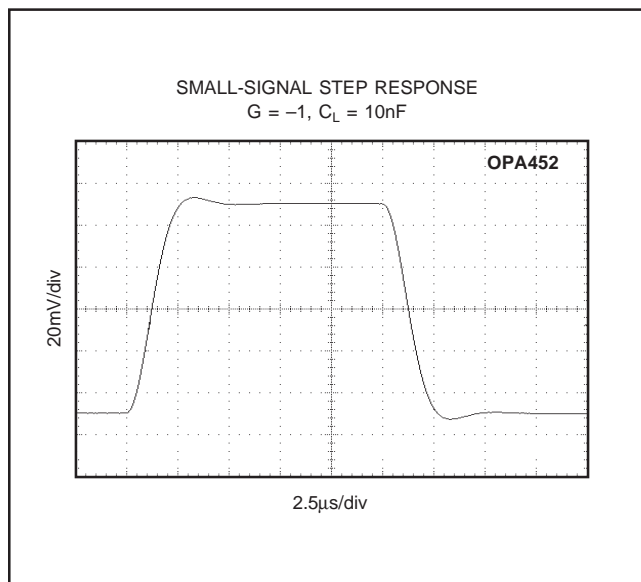

FIGURE 6. Small-Signal Step Response for Figure 5.

INCREASING OUTPUT CURRENT

In those applications where the 50mA of output current is not sufficient to drive the desired load, output current can be increased by connecting two or more OPA452s or OPA453s in parallel as shown in Figure 7. Amplifier A1 is the “master” amplifier and may be configured in virtually an op amp circuit. Amplifier A2, the “slave”, is configured as a unity gain buffer. Alternatively, external output transistors can be used to boost output current. The circuit in Figure 8 is capable of supplying output currents up to 1A. Alterna-

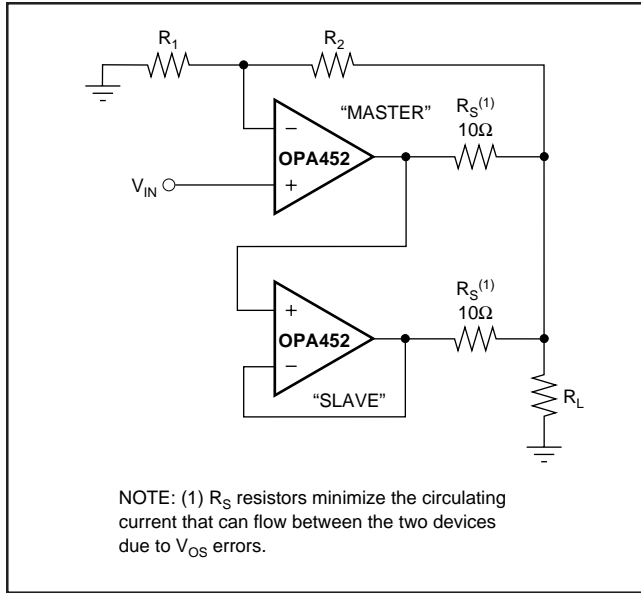

FIGURE 7. Parallel Amplifiers Increase Output Current Capability.

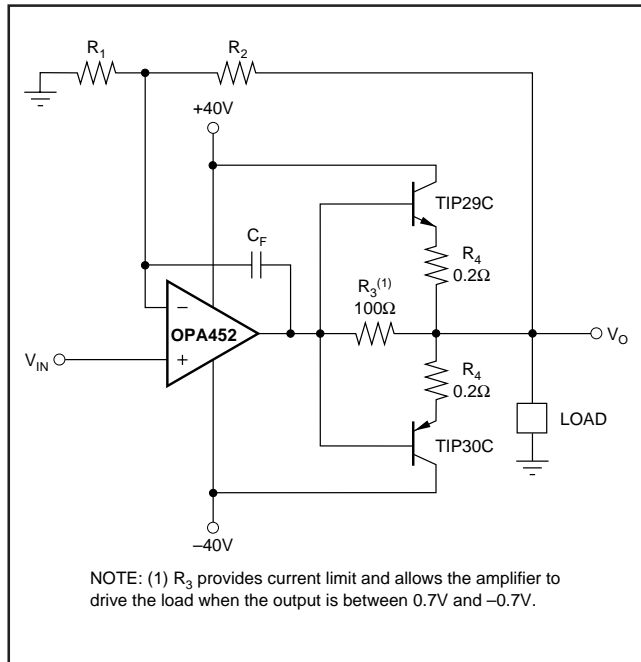

FIGURE 8. External Output Transistors Boost Output Current Up to 1 Amp.

tively, the OPA547, OPA548, and OPA549 series power op amps should be considered for high output current drive, along with programmable current limit and output disable capability.

INPUT PROTECTION

The OPA452 and OPA453 feature internal clamp diodes to protect the inputs when voltages beyond the supply rails are encountered. However, input current should be limited to 5mA. In some cases, an external series resistor may be required. Many input signals are inherently current-limited, therefore, a limiting resistor may not be required. Please consider that a “large” series resistor, in conjunction with the input capacitance, can affect stability.

USING THE OPA453 IN LOW GAINS

The OPA453 is intended for applications with signal gains of 5 or greater, but it is possible to take advantage of its high slew rate in lower gains using an external compensation technique in an inverting configuration. This technique maintains low noise characteristics of the OPA453 architecture at low frequencies. Depending on the application, a small increase in high frequency noise may result. This technique shapes the loop gain for good stability while giving an easily controlled second-order low-pass frequency response.

Considering only the noise gain (non-inverting signal gain) for the circuit of Figure 9 the low frequency noise gain (NG_1) will be set by the resistor ratios, while the high frequency noise gain (NG_2) will be set by the capacitor ratios. The capacitor values set both the transition frequencies and the high frequency noise gain. If this noise gain, determined by $NG_2 = 1 + C_S/C_F$, is set to a value greater than the recommended minimum stable gain for the op amp and the noise gain pole, set by $1/R_F C_F$, is placed correctly, a very well controlled, 2nd-order low-pass frequency response will result.

To choose the values for both C_S and C_F , two parameters and only three equations need to be solved. First, the target for the high frequency noise gain (NG_2) should be greater than the minimum stable gain for the OPA453. In the circuit in Figure 9, a target NG_2 of 10 is used. Second, the signal gain of -1 shown in Figure 10 sets the low frequency noise gain to $NG_1 = 1 + R_F/R_G (= 2$ in this example). Using these two gains, knowing the Gain Bandwidth Product (GBP) for the OPA453 (7.5MHz), and targeting a maximally flat 2nd-order, low-pass Butterworth frequency response ($Q = 0.707$), the key frequency in the compensation can be found.

For the values shown in Figure 9, the f_{-3dB} will be approximately 180kHz. This is less than that predicted by simply dividing the GBP by NG_1 . The compensation network controls the bandwidth to a lower value while providing good slew rate at the output and an exceptional distortion performance due to increased loop gain at frequencies below $NG_1 \cdot Z_0$. The capacitor values shown in Figure 10 are calculated for $NG_1 = 2$ and $NG_2 = 10$ with no adjustment for parasitics.

Actual circuit values can be optimized by check the small-signal step response with actual load conditions. Figure 9 shows the small-signal step response of this OPA453, $G = -1$ circuit with a 1000pF load. It is well-behaved with no tendency to oscillate. If C_S and C_F were removed, the circuit would be unstable.

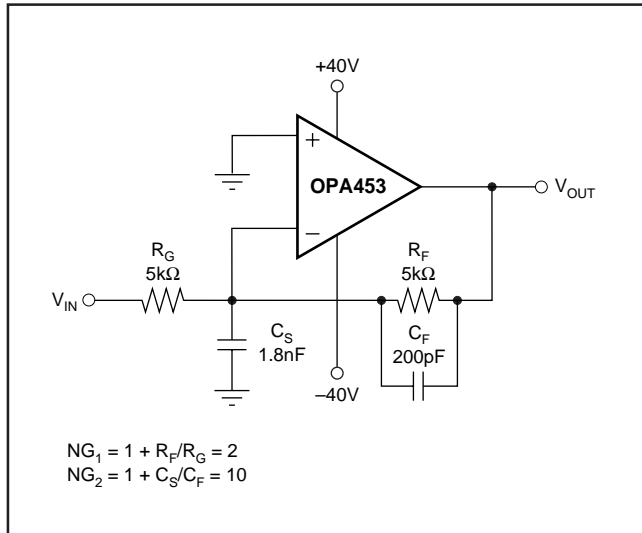

FIGURE 9. Compensation of the OPA453 for $G = 1$.

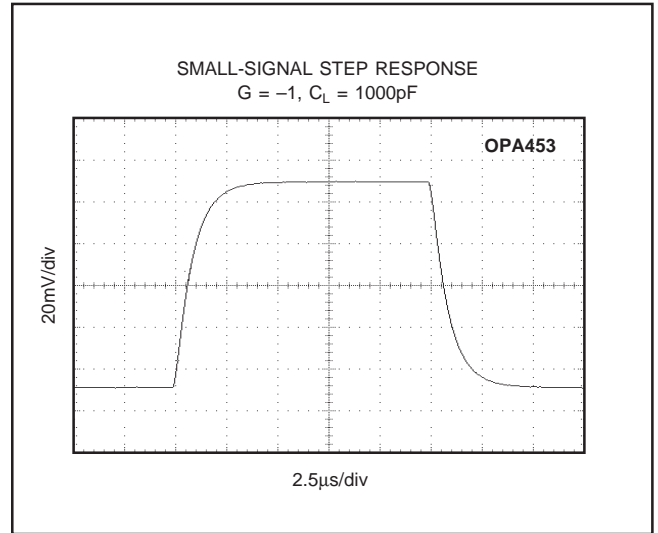

FIGURE 10. Small-Signal Step Response for Figure 9.