

**FAIRCHILD**  
SEMICONDUCTOR™

August 1986  
Revised May 2000

## DM74S373 • DM74S374

### 3-STATE Octal D-Type Transparent Latches and Edge-Triggered Flip-Flops

#### General Description

These 8-bit registers feature totem-pole 3-STATE outputs designed specifically for driving highly-capacitive or relatively low-impedance loads. The high-impedance state and increased high-logic-level drive provide these registers with the capability of being connected directly to and driving the bus lines in a bus-organized system without need for interface or pull-up components. They are particularly attractive for implementing buffer registers, I/O ports, bidirectional bus drivers, and working registers.

The eight latches of the DM74S373 are transparent D-type latches meaning that while the enable (G) is HIGH the Q outputs will follow the data (D) inputs. When the enable is taken LOW the output will be latched at the level of the data that was set up.

The eight flip-flops of the DM74S374 are edge-triggered D-type flip-flops. On the positive transition of the clock, the Q outputs will be set to the logic states that were set up at the D inputs.

Schmitt-trigger buffered inputs at the enable/clock lines simplify system design as ac and dc noise rejection is improved by typically 400 mV due to the input hysteresis. A buffered output control input can be used to place the eight outputs in either a normal logic state (HIGH or LOW logic levels) or a high-impedance state. In the high-impedance state the outputs neither load nor drive the bus lines significantly.

The output control does not affect the internal operation of the latches or flip-flops. That is, the old data can be retained or new data can be entered even while the outputs are OFF.

#### Features

- Choice of 8 latches or 8 D-type flip-flops in a single package
- 3-STATE bus-driving outputs
- Full parallel-access for loading
- Buffered control inputs
- P-N-P input reduce D-C loading on data lines

#### Ordering Code:

Order Number	Package Number	Package Description
DM74S373WM	M20B	20-Lead Small Outline Integrated Circuit (SOIC), JEDEC MS-013, 0.300 Wide
DM74S373N	N20A	20-Lead Plastic Dual-In-Line Package (PDIP), JEDEC MS-001, 0.300 Wide
DM74S374WM	M20B	20-Lead Small Outline Integrated Circuit (SOIC), JEDEC MS-013, 0.300 Wide
DM74S374N	N20A	20-Lead Plastic Dual-In-Line Package (PDIP), JEDEC MS-001, 0.300 Wide

Devices also available in Tape and Reel. Specify by appending the suffix letter "X" to the ordering code.

#### Connection Diagrams

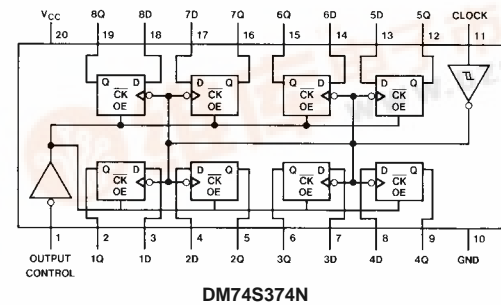
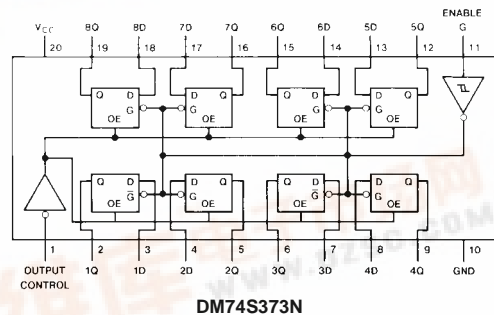

DM74S373 • DM74S374 3-STATE Octal D-Type Transparent Latches and Edge-Triggered Flip-Flops



### Truth Tables

DM74S373

Output Control	Enable G	D	Output
L	H	H	H
L	H	L	L
L	L	X	Q <sub>0</sub>
H	X	X	Z

DM74S374

Output Control	Clock	D	Output
L	↑	H	H
L	↑	L	L
L	L	X	Q <sub>0</sub>
H	X	X	Z

H = HIGH Level (Steady State)  
 L = LOW Level (Steady State)  
 X = Don't Care  
 Z = High Impedance State  
 ↑ = Transition from LOW-to-HIGH level,  
 Q<sub>0</sub> = The level of the output before steady-state input conditions were established.

### Logic Diagrams

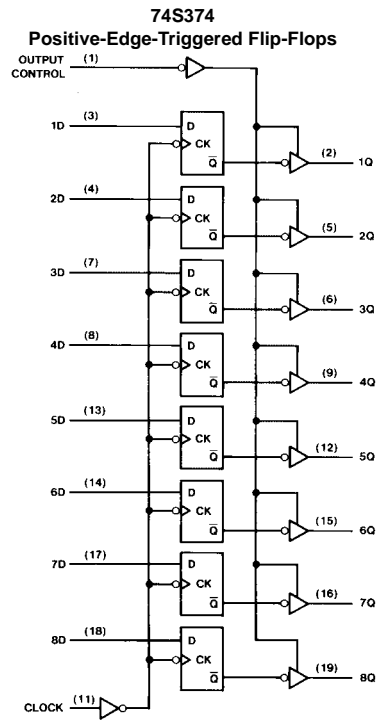
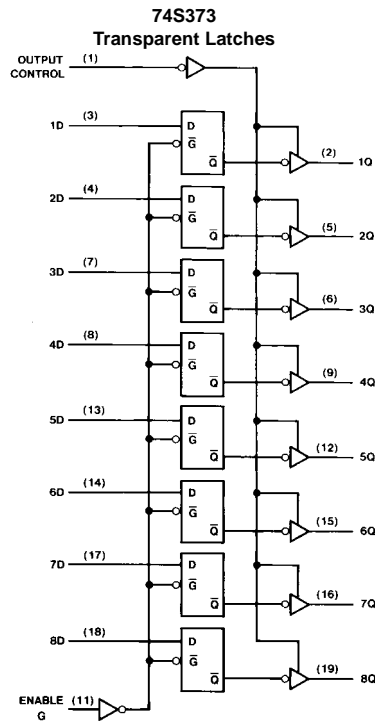

**Absolute Maximum Ratings**(Note 1)

Supply Voltage	7V
Input Voltage	5.5V
Operating Free Air Temperature Range	0°C to +70°C
Storage Temperature Range	-65°C to +150°C

**Note 1:** The "Absolute Maximum Ratings" are those values beyond which the safety of the device cannot be guaranteed. The device should not be operated at these limits. The parametric values defined in the Electrical Characteristics tables are not guaranteed at the absolute maximum ratings. The "Recommended Operating Conditions" table will define the conditions for actual device operation.

**DM74S373 Recommended Operating Conditions**

Symbol	Parameter	Min	Nom	Max	Units
$V_{CC}$	Supply Voltage	4.75	5	5.25	V
$V_{IH}$	HIGH Level Input Voltage	2			V
$V_{IL}$	LOW Level Input Voltage			0.8	V
$I_{OH}$	HIGH Level Output Current			-6.5	mA
$I_{OL}$	LOW Level Output Current			20	mA
$t_W$	Pulse Width (Note 2)	Enable HIGH	6		ns
		Enable LOW	7.3		
$t_W$	Pulse Width (Note 3)	Enable HIGH	15		ns
		Enable LOW	15		ns
$t_{SU}$	Data Setup Time (Note 4)(Note 5)	0↓			ns
$t_H$	Data Hold Time (Note 4)(Note 5)	10↓			ns
$T_A$	Free Air Operating Temperature	0		70	°C

**Note 2:**  $C_L = 15$  pF,  $R_L = 280\Omega$ ,  $T_A = 25^\circ\text{C}$  and  $V_{CC} = 5\text{V}$ .

**Note 3:**  $C_L = 50$  pF and  $R_L = 280\Omega$ ,  $T_A = 25^\circ\text{C}$  and  $V_{CC} = 5\text{V}$ .

**Note 4:** The symbol (↓) indicates the falling edge of the clock pulse is used for reference.

**Note 5:**  $T_A = 25^\circ\text{C}$  and  $V_{CC} = 5\text{V}$ .

**DM74S373 Electrical Characteristics**

over recommended operating free air temperature (unless otherwise noted)

Symbol	Parameter	Conditions	Min	Typ (Note 6)	Max	Units
$V_I$	Input Clamp Voltage	$V_{CC} = \text{Min}$ , $I_I = -18$ mA			-1.2	V
$V_{OH}$	HIGH Level	$V_{CC} = \text{Min}$ , $I_{OH} = \text{Max}$	2.4	3.2		V
	Output Voltage	$V_{IL} = \text{Max}$ , $V_{IH} = \text{Min}$				
$V_{OL}$	LOW Level	$V_{CC} = \text{Min}$ , $I_{OL} = \text{Max}$			0.5	V
	Output Voltage	$V_{IH} = \text{Min}$ , $V_{IL} = \text{Max}$				
$I_I$	Input Current @ Max Input Voltage	$V_{CC} = \text{Max}$ , $V_I = 5.5\text{V}$			1	mA
$I_{IH}$	HIGH Level Input Current	$V_{CC} = \text{Max}$ , $V_I = 2.7\text{V}$			50	$\mu\text{A}$
$I_{IL}$	LOW Level Input Current	$V_{CC} = \text{Max}$ , $V_I = 0.5\text{V}$			-250	$\mu\text{A}$
$I_{OZH}$	Off-State Output Current with HIGH Level Output Voltage Applied	$V_{CC} = \text{Max}$ , $V_O = 2.4\text{V}$ $V_{IH} = \text{Min}$ , $V_{IL} = \text{Max}$			50	$\mu\text{A}$
$I_{OZL}$	Off-State Output Current with LOW Level Output Voltage Applied	$V_{CC} = \text{Max}$ , $V_O = 0.5\text{V}$ $V_{IH} = \text{Min}$ , $V_{IL} = \text{Max}$			-50	$\mu\text{A}$
$I_{OS}$	Short Circuit Output Current	$V_{CC} = \text{Max}$ (Note 7)	-40		-100	mA
$I_{CC}$	Supply Current	$V_{CC} = \text{Max}$		105	160	mA
		Outputs HIGH or LOW			190	
		Outputs Disabled				

**Note 6:** All typicals are at  $V_{CC} = 5\text{V}$ ,  $T_A = 25^\circ\text{C}$ .

**Note 7:** Not more than one output should be shorted at a time, and the duration should not exceed one second.

**DM74S373 Switching Characteristics**at  $V_{CC} = 5V$  and  $T_A = 25^\circ C$ 

Symbol	Parameter	From (Input) To (Output)	$R_L = 280\Omega$				Units
			$C_L = 15\text{ pF}$		$C_L = 50\text{ pF}$		
			Min	Max	Min	Max	
$t_{PLH}$	Propagation Delay Time LOW-to-HIGH Level Output	Data to Any Q		12		14	ns
$t_{PHL}$	Propagation Delay Time HIGH-to-LOW Level Output	Data to Any Q		12		16	ns
$t_{PLH}$	Propagation Delay Time LOW-to-HIGH Level Output	Enable to Any Q		14		14	ns
$t_{PHL}$	Propagation Delay Time HIGH-to-LOW Level Output	Enable to Any Q		18		21	ns
$t_{PZH}$	Enable Time to HIGH Level Output	Output Control to Any Q		15		17	ns
$t_{PZL}$	Output Enable Time to LOW Level Output	Output Control to Any Q		18		23	ns
$t_{PHZ}$	Output Disable Time to HIGH Level Output (Note 8)	Output Control to Any Q		9			ns
$t_{PLZ}$	Output Disable Time to LOW Level Output (Note 8)	Output Control to Any Q		12			ns

**Note 8:**  $C_L = 5\text{ pF}$ **DM74S374 Recommended Operating Conditions**

Symbol	Parameter	Min	Nom	Max	Units
$V_{CC}$	Supply Voltage	4.75	5	5.25	V
$V_{IH}$	HIGH Level Input Voltage				V
$V_{IL}$	LOW Level Input Voltage			0.8	V
$I_{OH}$	HIGH Level Output Current			-6.5	mA
$I_{OL}$	LOW Level Output Current			20	mA
$f_{CLK}$	Clock Frequency (Note 9)	0		75	MHz
$f_{CLK}$	Clock Frequency (Note 10)	0		75	MHz
$t_w$	Pulse Width (Note 9)	Clock HIGH	6		ns
		Clock LOW	7.3		
	Pulse Width (Note 10)	Clock HIGH	15		
		Clock LOW	15		
$t_{SU}$	Data Setup Time (Note 11)(Note 12)	$5\uparrow$			ns
$t_H$	Data Hold Time (Note 11)(Note 12)	$2\uparrow$			ns
$T_A$	Free Air Operating Temperature	0		70	$^\circ C$

**Note 9:**  $C_L = 15\text{ pF}$ ,  $R_L = 280\Omega$ ,  $T_A = 25^\circ C$  and  $V_{CC} = 5V$ .**Note 10:**  $C_L = 50\text{ pF}$ ,  $R_L = 280\Omega$ ,  $T_A = 25^\circ C$  and  $V_{CC} = 5V$ .**Note 11:** The symbol ( $\uparrow$ ) indicates the rising edge of the clock pulse is used for reference.**Note 12:**  $T_A = 25^\circ C$  and  $V_{CC} = 5V$ .

## DM74S374 Electrical Characteristics

over recommended operating free air temperature (unless otherwise noted)

Symbol	Parameter	Conditions	Min	Typ (Note 13)	Max	Units
$V_I$	Input Clamp Voltage	$V_{CC} = \text{Min}, I_I = -18 \text{ mA}$			-1.2	V
$V_{OH}$	HIGH Level Output Voltage	$V_{CC} = \text{Min}, I_{OH} = \text{Max}$ $V_{IL} = \text{Max}, V_{IH} = \text{Min}$	2.4	3.2		V
$V_{OL}$	LOW Level Output Voltage	$V_{CC} = \text{Min}, I_{OL} = \text{Max}$ $V_{IH} = \text{Min}, V_{IL} = \text{Max}$			0.5	V
$I_I$	Input Current @ Max Input Voltage	$V_{CC} = \text{Max}, V_I = 5.5\text{V}$			1	mA
$I_H$	HIGH Level Input Current	$V_{CC} = \text{Max}, V_I = 2.7\text{V}$			50	$\mu\text{A}$
$I_{IL}$	LOW Level Input Current	$V_{CC} = \text{Max}, V_I = 0.5\text{V}$			-250	$\mu\text{A}$
$I_{OZH}$	Off-State Output Current with HIGH Level Output Voltage Applied	$V_{CC} = \text{Max}, V_O = 2.4\text{V}$ $V_{IH} = \text{Min}, V_{IL} = \text{Max}$			50	$\mu\text{A}$
$I_{OZL}$	Off-State Output Current with LOW Level Output Voltage Applied	$V_{CC} = \text{Max}, V_O = 0.5\text{V}$ $V_{IH} = \text{Min}, V_{IL} = \text{Max}$			-50	$\mu\text{A}$
$I_{OS}$	Short Circuit Output Current	$V_{CC} = \text{Max}$ (Note 14)	-40		-100	mA
$I_{CC}$	Supply Current	$V_{CC} = \text{Max}$				
		Outputs HIGH			110	
		Outputs LOW		90	140	mA
		Outputs Disabled			160	

**Note 13:** All typicals are at  $V_{CC} = 5\text{V}$ ,  $T_A = 25^\circ\text{C}$ .

**Note 14:** Not more than one output should be shorted at a time, and the duration should not exceed one second.

## DM74S374 Switching Characteristics

at  $V_{CC} = 5\text{V}$  and  $T_A = 25^\circ\text{C}$

Symbol	Parameter	From (Input) To (Output)	$R_L = 280\Omega$				Units
			$C_L = 15 \text{ pF}$		$C_L = 50 \text{ pF}$		
			Min	Max	Min	Max	
$f_{MAX}$	Maximum Clock Frequency			75		75	MHz
$t_{PLH}$	Propagation Delay Time LOW-to-HIGH Level Output	Clock to Any Q		15		15	ns
$t_{PHL}$	Propagation Delay Time HIGH-to-LOW Level Output	Clock to Any Q		17		20	ns
$t_{PZH}$	Output Enable Time to HIGH Level Output	Output Control to Any Q		15		17	ns
$t_{PZL}$	Output Enable Time to LOW Level Output	Output Control to Any Q		18		23	ns
$t_{PHZ}$	Output Disable Time from HIGH Level Output (Note 15)	Output Control to Any Q		9			ns
$t_{PLZ}$	Output Disable Time from LOW Level Output (Note 15)	Output Control to Any Q		12			ns

**Note 15:**  $C_L = 5 \text{ pF}$

**Physical Dimensions** inches (millimeters) unless otherwise noted

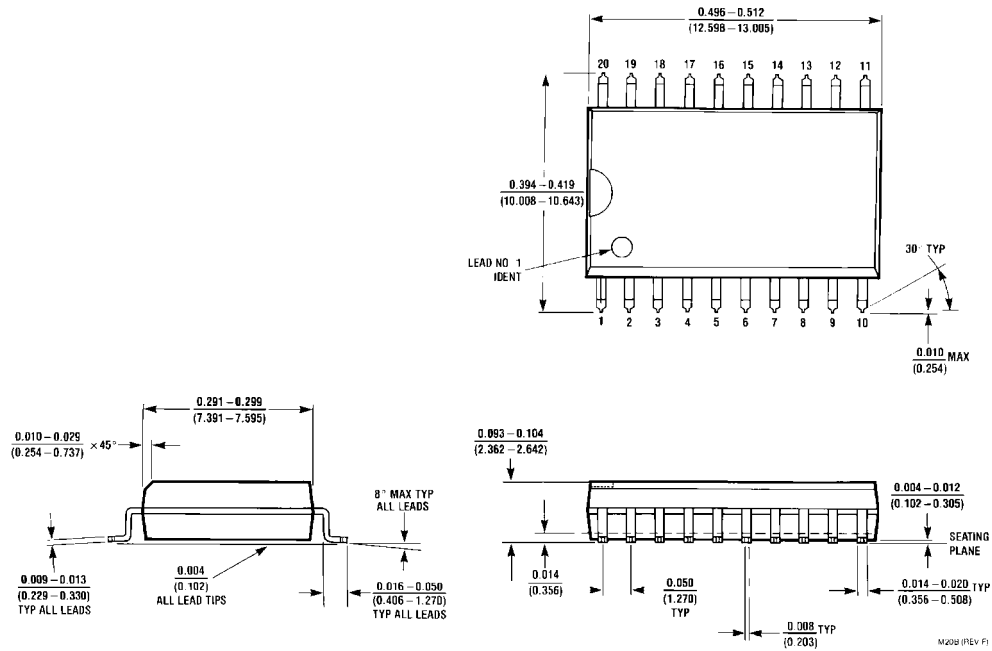

**20-Lead Small Outline Integrated Circuit (SOIC), JEDEC MS-013, 0.300 Wide  
Package Number M20B**

**Physical Dimensions** inches (millimeters) unless otherwise noted (Continued)

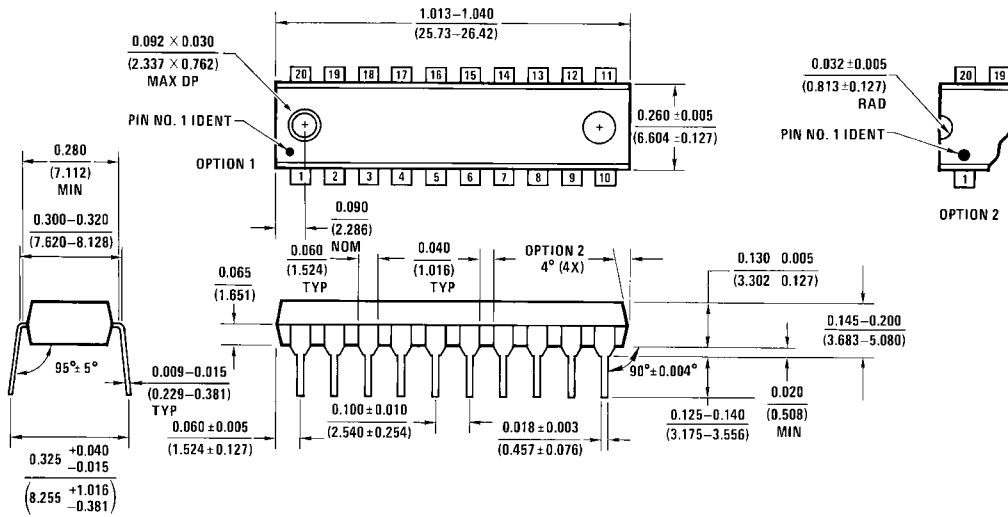

**20-Lead Plastic Dual-In-Line Package (PDIP), JEDEC MS-001, 0.300 Wide  
Package Number N20A**

N20A (REV. G)

Fairchild does not assume any responsibility for use of any circuitry described, no circuit patent licenses are implied and Fairchild reserves the right at any time without notice to change said circuitry and specifications.

**LIFE SUPPORT POLICY**

FAIRCHILD'S PRODUCTS ARE NOT AUTHORIZED FOR USE AS CRITICAL COMPONENTS IN LIFE SUPPORT DEVICES OR SYSTEMS WITHOUT THE EXPRESS WRITTEN APPROVAL OF THE PRESIDENT OF FAIRCHILD SEMICONDUCTOR CORPORATION. As used herein:

1. Life support devices or systems are devices or systems which, (a) are intended for surgical implant into the body, or (b) support or sustain life, and (c) whose failure to perform when properly used in accordance with instructions for use provided in the labeling, can be reasonably expected to result in a significant injury to the user.
2. A critical component in any component of a life support device or system whose failure to perform can be reasonably expected to cause the failure of the life support device or system, or to affect its safety or effectiveness.

[www.fairchildsemi.com](http://www.fairchildsemi.com)