



PRELIMINARY
September 2003

LM96010 Hardware Monitor with Dual Thermal Diodes and SensorPath™ Bus

General Description

The LM96010 is part of a hardware monitor system, comprised of two parts the Super I/O (Master) and LM96010 (slave). The LM96010 will be controlled by the Master and report to the master temperature, and voltage measurements using the SensorPath™ single-wire bus. The LM96010 measures the temperature of its own die as well as two external devices such as a processor thermal diode or a diode connected transistor. The LM96010 can resolve temperatures up to 140°C and down to -55°C. Using $\Sigma\Delta$ ADC it measures V_{ccp}, +2.5V, +3.3V, +5V and +12V analog input voltages with internal scaling resistors.

Features

- SensorPath Interface
 - 2 hardware programmable addresses
- Voltage Monitoring
 - 9-bit $\Sigma\Delta$ ADC
 - Internal scaling resistors for all inputs
 - Monitors V_{ccp}, +2.5 V, +3.3 V, +5 V and +12 V
- Temperature Sensing

- 2 remote diode temperature sensor zones
- Internal local temperature zone
- 0.5 °C resolution
- Measures temperatures up to 140 °C
- 14-lead TSSOP package

Key Specifications

- Voltage Measurement Accuracy ±2 % (max)
- Temperature Sensor Accuracy ±3 °C (max)
- Temperature Range:
 - LM96010 junction 0 °C to +85 °C
 - Remote Temp Accuracy +25 °C to +100 °C
- Power Supply Voltage +3.0 V to +3.6 V
- Average Power Supply Current 0.5 mA (typ)
- Round-robin Conversion of All Channels 182 ms

Applications

- Microprocessor based equipment
(Motherboards, Video Cards, Base-stations, Routers, ATMs, Point of Sale, ...)

Typical Application

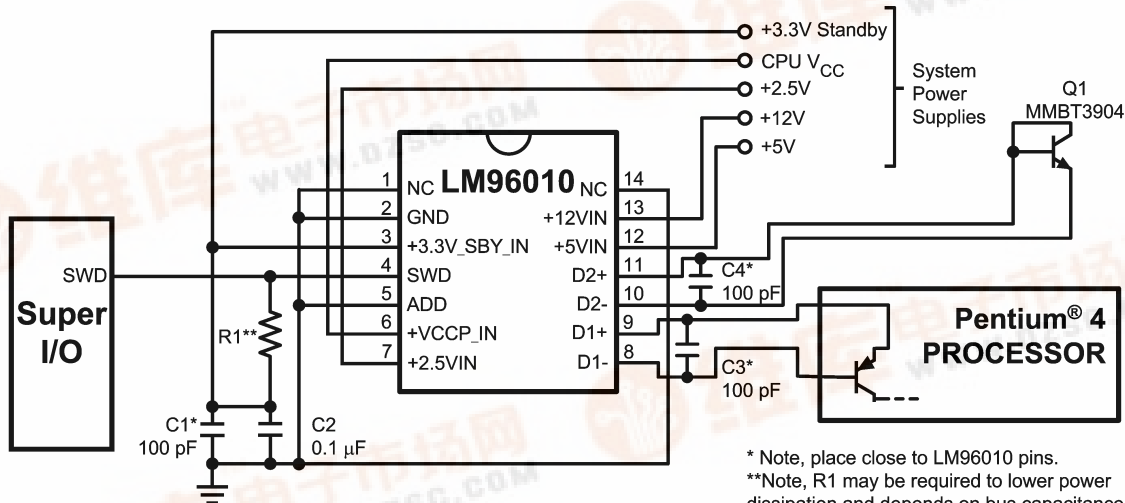

* Note, place close to LM96010 pins.
**Note, R1 may be required to lower power dissipation and depends on bus capacitance.

20081703

LM96010 Hardware Monitor with Dual Thermal Diodes and SensorPath Bus



Block Diagram

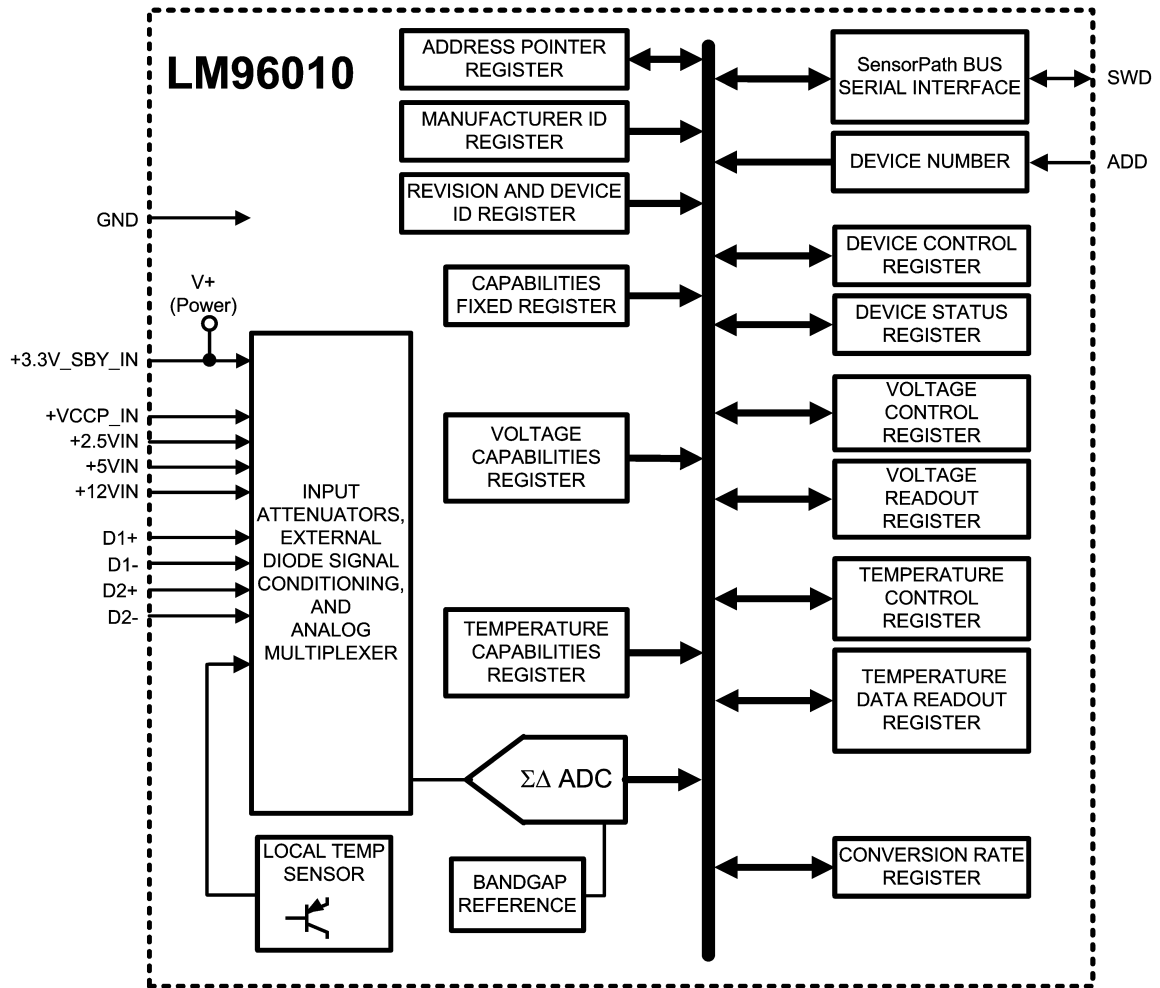

20081701

LIFE SUPPORT POLICY

NATIONAL'S PRODUCTS ARE NOT AUTHORIZED FOR USE AS CRITICAL COMPONENTS IN LIFE SUPPORT DEVICES OR SYSTEMS WITHOUT THE EXPRESS WRITTEN APPROVAL OF THE PRESIDENT AND GENERAL COUNSEL OF NATIONAL SEMICONDUCTOR CORPORATION. As used herein:

1. Life support devices or systems are devices or systems which, (a) are intended for surgical implant into the body, or (b) support or sustain life, and whose failure to perform when properly used in accordance with instructions for use provided in the labeling, can be reasonably expected to result in a significant injury to the user.
2. A critical component is any component of a life support device or system whose failure to perform can be reasonably expected to cause the failure of the life support device or system, or to affect its safety or effectiveness.



National Semiconductor
Americas Customer
Support Center
Email: new.feedback@nsc.com
Tel: 1-800-272-9959

National Semiconductor
Europe Customer Support Center
Fax: +49 (0) 180-530 85 86
Email: europe.support@nsc.com
Deutsch Tel: +49 (0) 69 9508 6208
English Tel: +44 (0) 870 24 0 2171
Français Tel: +33 (0) 1 41 91 8790

National Semiconductor
Asia Pacific Customer
Support Center
Email: ap.support@nsc.com

National Semiconductor
Japan Customer Support Center
Fax: 81-3-5639-7507
Email: jpn.feedback@nsc.com
Tel: 81-3-5639-7560

www.national.com