

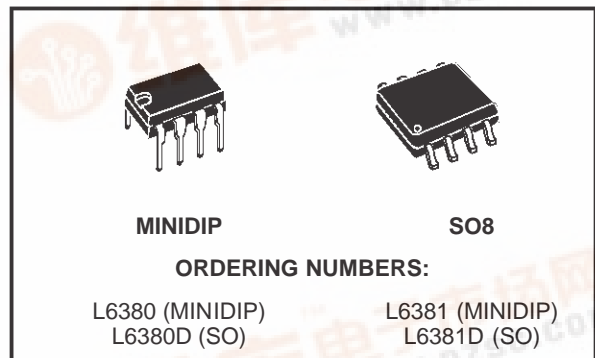

# L6380 L6381

## HIGH VOLTAGE HIGH-SIDE DRIVER

- V<sub>H.V.</sub> UP TO 600 V
- SUPPLY VOLTAGE UP TO 17 V
- DRIVER CURRENT CAPABILITY:  
SINK CURRENT = 200 mA  
SOURCE CURRENT = 100 mA
- UNDER VOLTAGE LOCKOUT WITH HYS-TERESIS
- CMOS/LSTTL COMPATIBLE INVERTING IN-PUT
- dV/dt IMMUNITY ± 50 V/nS IN FULL TEM-PERATURE RANGE
- CURRENT MODE CONTROL REFERENCE INPUT
- CURRENT/VOLTAGE MODE OPERATION (L6380)
- VOLTAGE MODE OPERATION (L6381)
- 8 PINS PACKAGE



### DESCRIPTION

The L6380/L6381 is a high-voltage device with a

driving stage floating up to 600V.

It can be used to drive N-channel power MOSFET and IGBT, in high-side and low-side configurations.

The device has a logic input (CMOS and LSTTL compatible) and two comparator inputs compatible to ground.

### L6380 BLOCK DIAGRAM

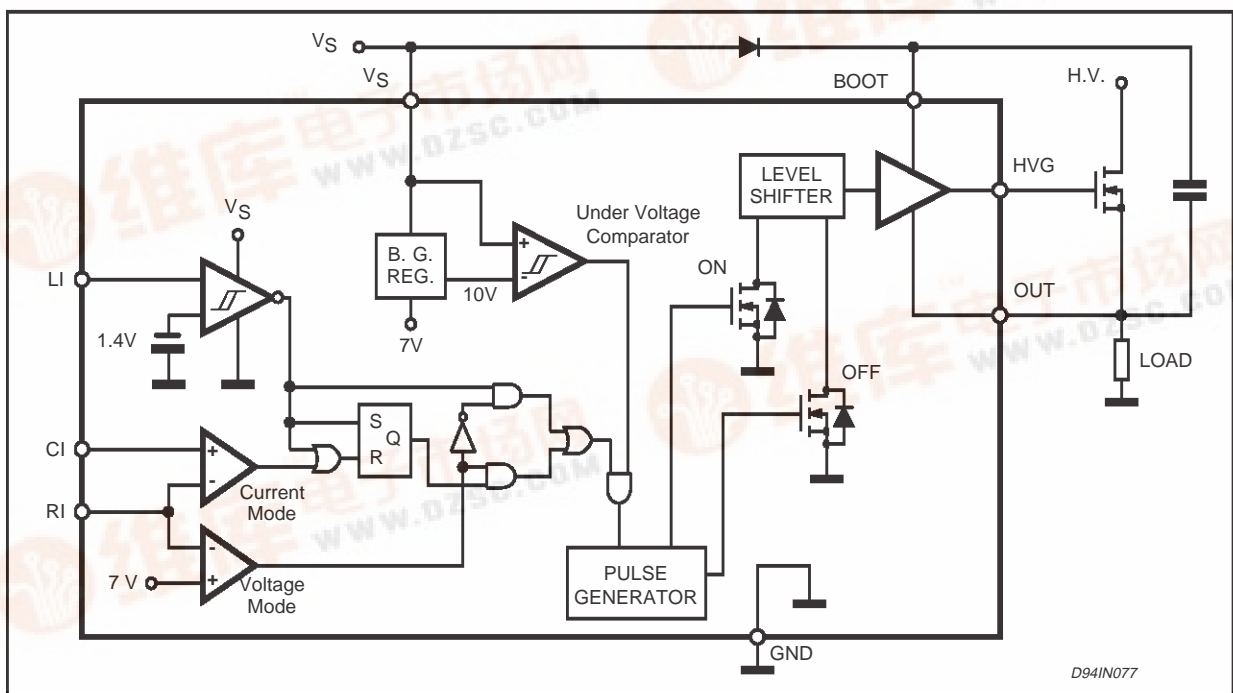

## L6380 - L6381

To drive the external power device the signal coming from input logic is fed into a pulse generator that in turns drives the level shifting structure (that include two High Voltage DMOS) designed to ensure low power dissipation and high noise immunity. The output buffer (in Totem Pole arrangement) is able to sink from or source to the gate of the external device the current needed to switch it ON or OFF.

The falling edge of the signal coming from the input logic will turn ON while the rising edge will turn OFF the driven power device. This operation will ensure low current sinking from the HV rail during commutations.

### Current / Voltage Mode Operation

To select the Voltage Mode Operation the user have to set on the RI pin a voltage higher than the internal reference (7V). In this way the IC will function as an inverting buffer driven by the LI input pin (see Voltage Mode Timing Diagram).

If the voltage on RI input pin is lower than 7V the Current Mode Operation will be enabled. In this configuration the RI input will set the reference

voltage to the non inverting input of the Current Mode Comparator (see block diagram), whose inverting input, the CI input pin, is allowable to close a current control loop with a voltage drop coming from a sense resistor. To summarise (see Current Mode Timing Diagrams):

The output of the Current Mode Comparator will mask the LI input whenever the CI voltage is higher than the RI input (and the RI voltage is below 7V).

### Under Voltage Lockout

The output buffer is switched off whenever  $V_s$  decrease below  $V_{th}$  OFF.

The IC will remain in this shut down status until  $V_s$  has risen above  $V_{thON}$ , the hysteresis will provide a good noise immunity.

### Applications

The L6380/L6381 can be used in motor control applications (AC, DC and switched reluctance), electronic ballasts, heating and welding, switching power supplies and UPS.

## L6381 BLOCK DIAGRAM

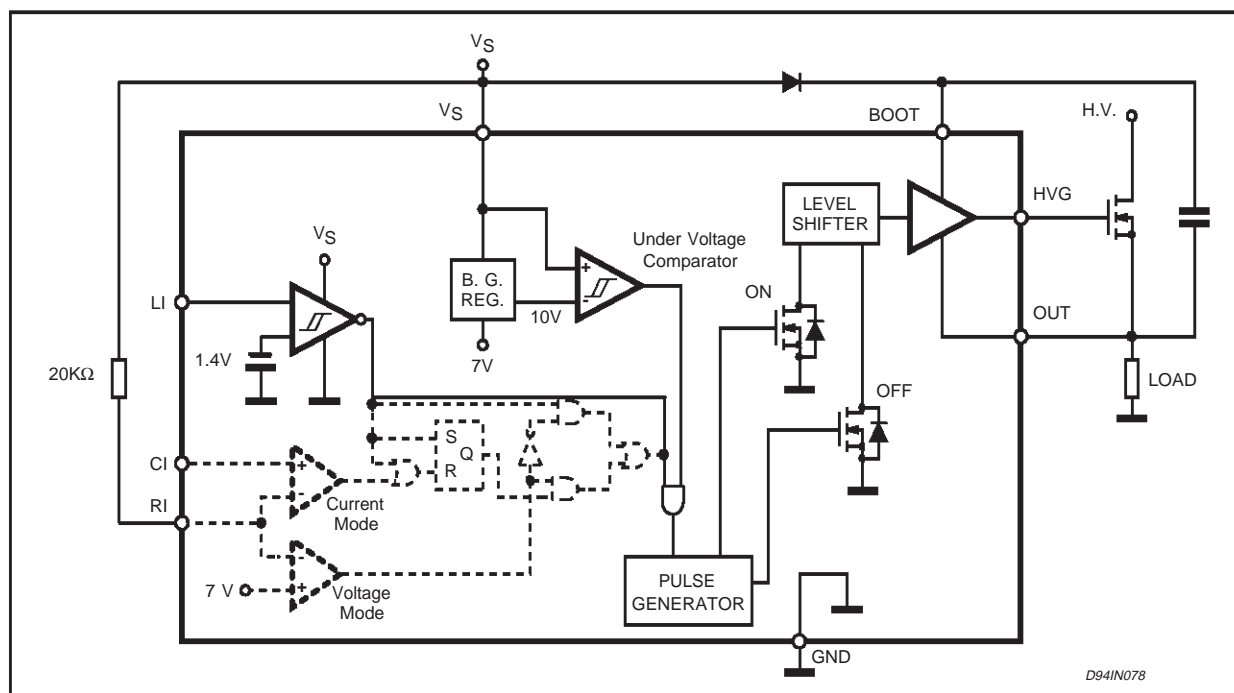

## ABSOLUTE MAXIMUM RATINGS

Symbol	Parameter	Value	Unit
$V_{BOOT}$	Supply voltage of bootstrapped section	$600+V_S$	V
$V_{HVG}$	Gate voltage of upper driver	$600+V_S$	V
$V_{OUT}$	Output voltage	600	V
$V_{BOOT} - V_{OUT}$	Difference between boot voltage and output voltage	18	V
$V_{HVG} - V_{OUT}$	Difference between gate voltage of upper gate and output voltage	18	V
$V_S$	Supply voltage	18	V
$V_{IN}$	Input voltage	$V_S-2V$	V
$dV_{OUT}/dt$	Transient offset supply voltage	$\pm 50$	V/ns
$V_{OUT} - V_{GND}$	Difference between output voltage and ground ( $t_p \leq 100$ ns)	-10	V
$T_{amb}$	Ambient Temperature Range (operative)	-25 to +85	°C
$T_J$	Junction temperature	150	°C
$T_{ST}$	Storage temperature	-40 to +150	°C
$P_{tot}$	Total Power Dissipation (at $T_j = 85^\circ\text{C}$ )	650	mW

Note: ESD immunity for pins 1, 2 and 3 is guaranteed up to 900V (Human Body Model)

## THERMAL DATA

Symbol	Parameter	MINIDIP	SO8	Unit
$R_{th\ j-amb}$	Thermal Resistance, Junction Ambient	Max. 100	150	°C/W

## L6380 PIN CONNECTION (Top view)

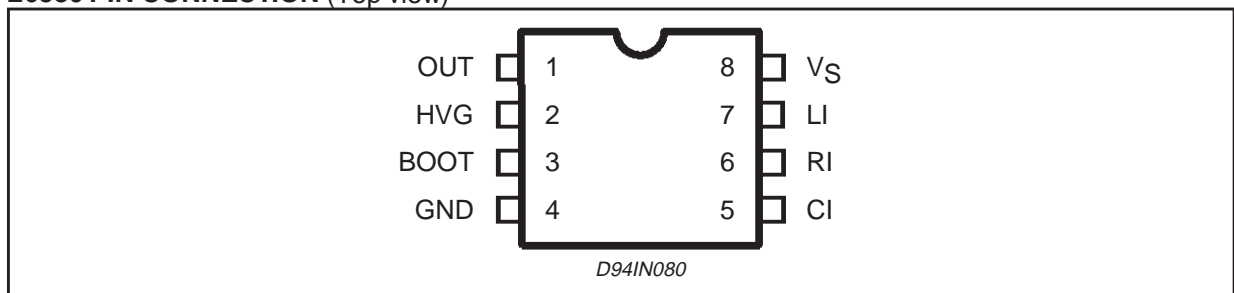

## L6381 PIN CONNECTION (Top view)

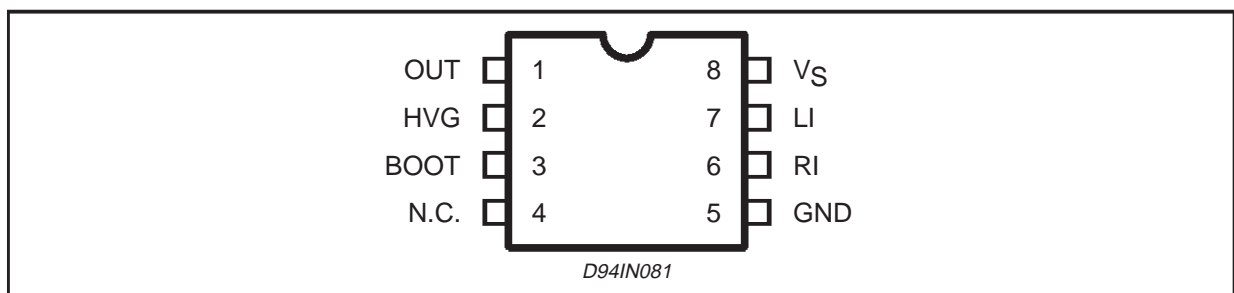

## L6380 - L6381

### ELECTRICAL CHARACTERISTICS

DC OPERATION ( $V_S = 15V$ ;  $T_j = 25^\circ C$ ; unless otherwise specified.)

Symbol	Pin	Parameter	Test Condition	Min.	Typ.	Max.	Unit
$V_S$	8	Supply Voltage (operative)				17	V
$V_{thON}$		UV Turn-On Theshold		10	10.5	11	V
$V_{thOFF}$		UV Turn-Off Theshold		9	9.5	10	V
$V_{Shys}$		UV Hysteresis		0.5	0.75	1	V
$I_q$		Quiescent Current Before Start-Up	$V_S \leq 8V$		300	700	mA
$I_{qs}$		Quiescent Supply Current			2	3	mA
$V_{il}$	7	Logic Input Low Level				0.8	V
$V_{ih}$		Logic Input High Level		2			V
$V_{co}$	6 vs 5	Input Comparator Offset				100	mV
$V_{thRI}$	6	Mode Selection Internal Threshold Voltage		6.5	7	7.5	V
$I_{so}$	2	Source Current	$V_{BOOT}-V_{OUT}=12V$ ; $V_{HVG}-V_{OUT}=0V$ ; $t_p \leq 10\mu s$	130		230	mA
$I_{si}$		Sink Current	$V_{BOOT}-V_{OUT}=12V$ ; $V_{HVG}-V_{OUT}=6V$ ; $t_p \leq 10\mu s$	-320		-180	mA
$I_{qBOOT}$	3	Boot Supply Quiescent Current	$V_{HVG} = V_{BOOT}$		70		$\mu A$
$I_{lkgBOOT}$		Boot Leakage Current	$V_{BOOT}=500V$			10	$\mu A$
$I_{lkgHVG}$	2	Gate Driver Leakage Current	$V_{HVG}=500V$			10	$\mu A$
$I_{lkgOUT}$	1	Output Leakage Current	$V_{OUT}=500V$			10	$\mu A$
$I_{bias}$	5, 6	Input Bias Current				2	$\mu A$
	7					30	$\mu A$

AC OPERATION ( $V_S = 15V$ ;  $T_j = 25^\circ C$ ; unless otherwise specified.)

Symbol	Parameter	Test Condition	Min.	Typ.	Max.	Unit
$t_r$	Gate Driver Rise Time	$C_L(HVG, OUT)=1nF$ ; $V_{OUT}=0$ to $500V$		70	100	ns
$t_f$	Gate Driver Fall Time			50	100	ns
$t_{ON}$	Turn-On Delay				400	ns
$t_{OFF}$	Turn-Off Delay				400	ns

Figure 1: AC Operation Test Circuit

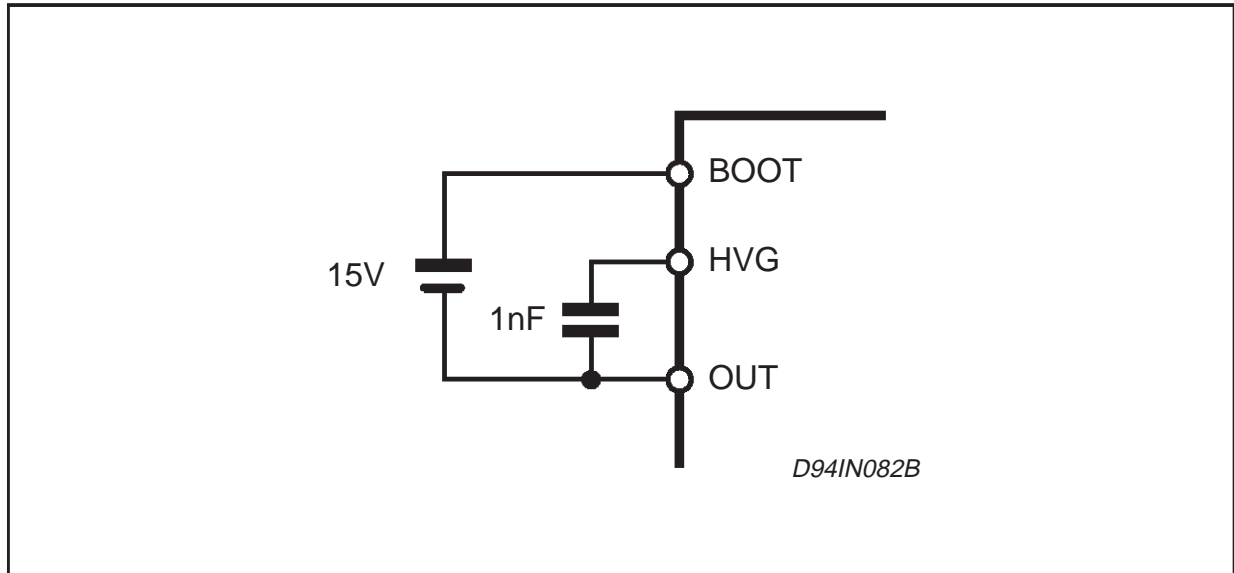
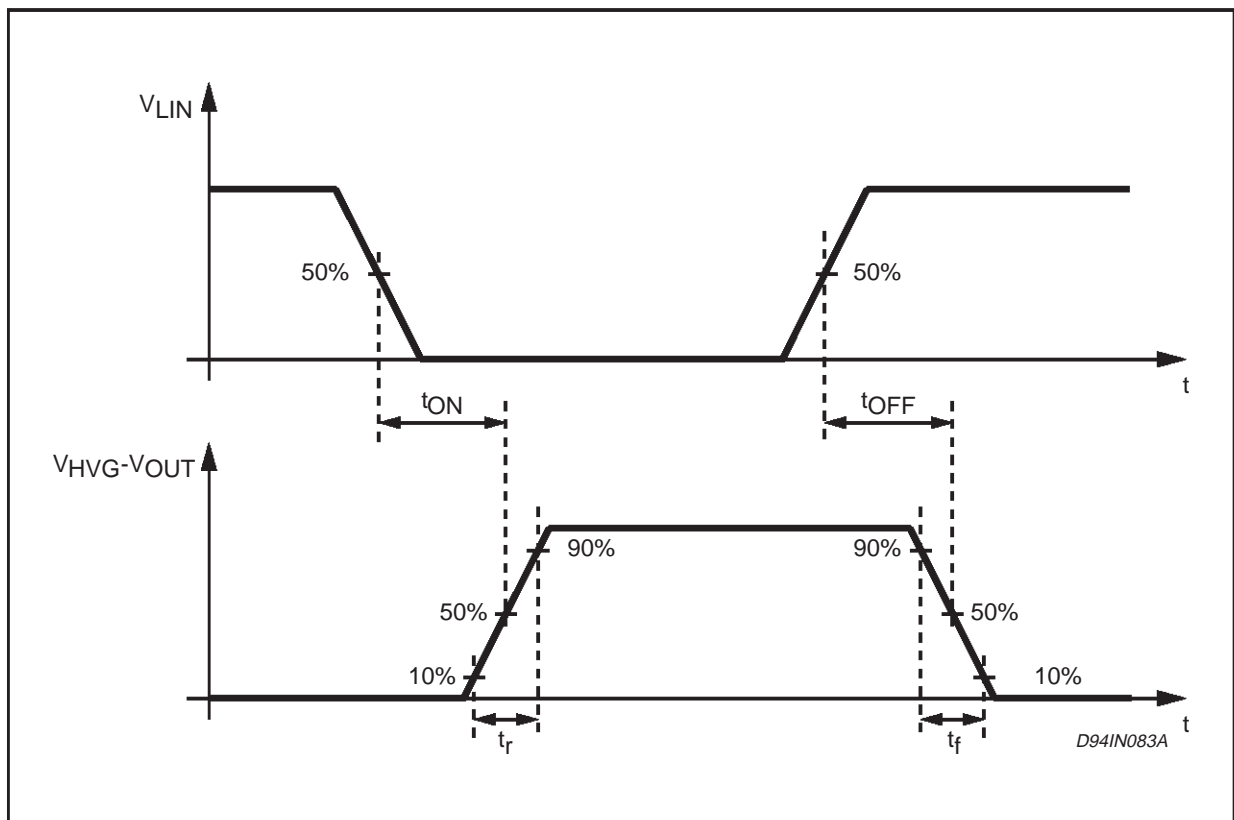
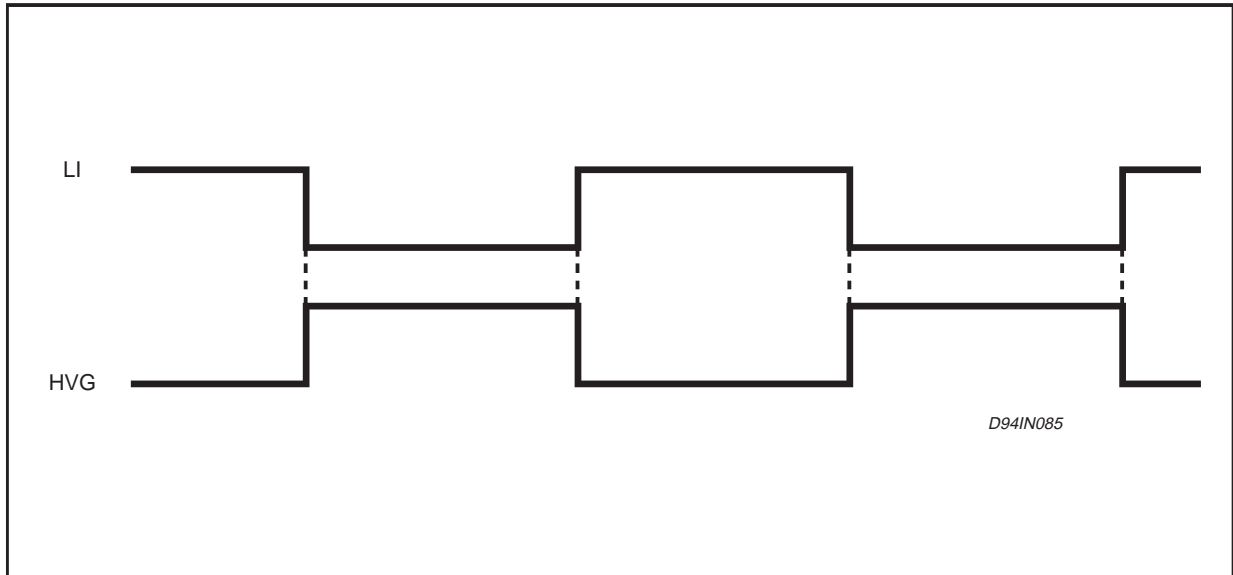

Figure 2: Switching Waveforms



Voltage Mode Timing Diagrams



Current Mode Timing Diagrams

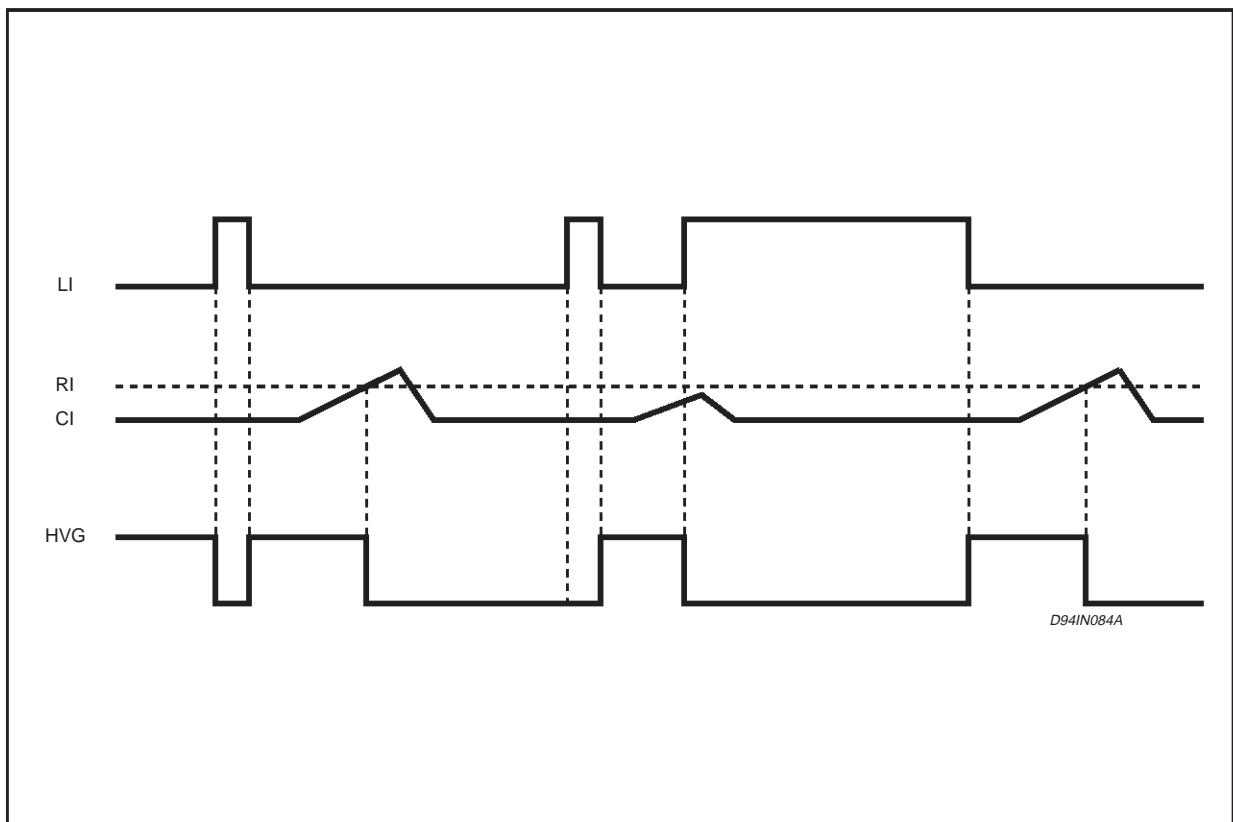

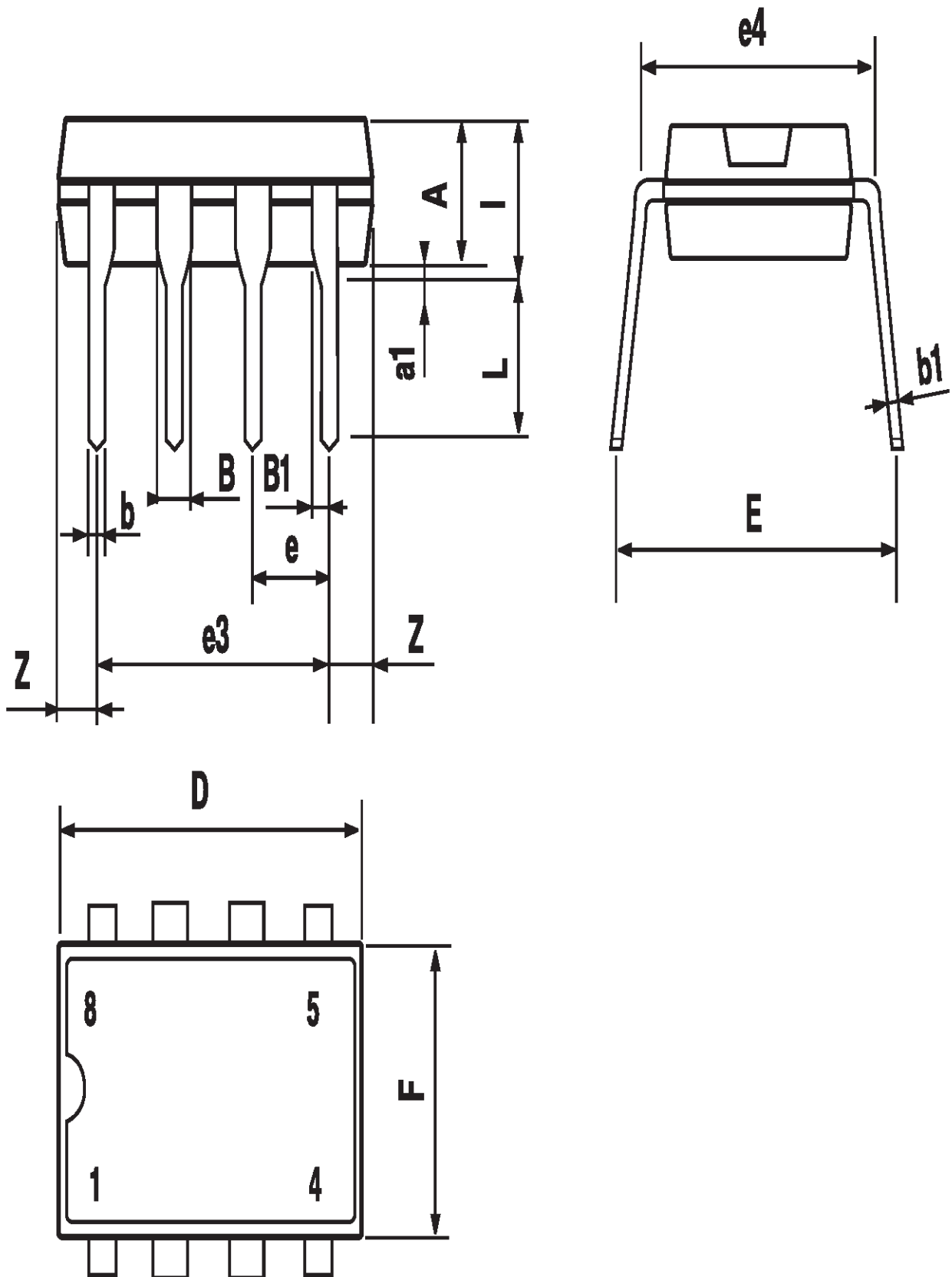

## L6380 - L6381

DIM.	mm			inch		
	MIN.	TYP.	MAX.	MIN.	TYP.	MAX.
A			1.75			0.069
a1	0.1		0.25	0.004		0.010
a2			1.65			0.065
a3	0.65		0.85	0.026		0.033
b	0.35		0.48	0.014		0.019
b1	0.19		0.25	0.007		0.010
C	0.25		0.5	0.010		0.020
c1	45° (typ.)					
D (1)	4.8		5.0	0.189		0.197
E	5.8		6.2	0.228		0.244
e		1.27			0.050	
e3		3.81			0.150	
F (1)	3.8		4.0	0.15		0.157
L	0.4		1.27	0.016		0.050
M			0.6			0.024
S	8° (max.)					

### OUTLINE AND MECHANICAL DATA

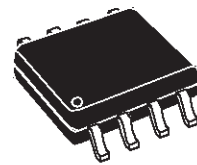

**SO8**

(1) D and F do not include mold flash or protrusions. Mold flash or protrusions shall not exceed 0.15mm (.006inch).

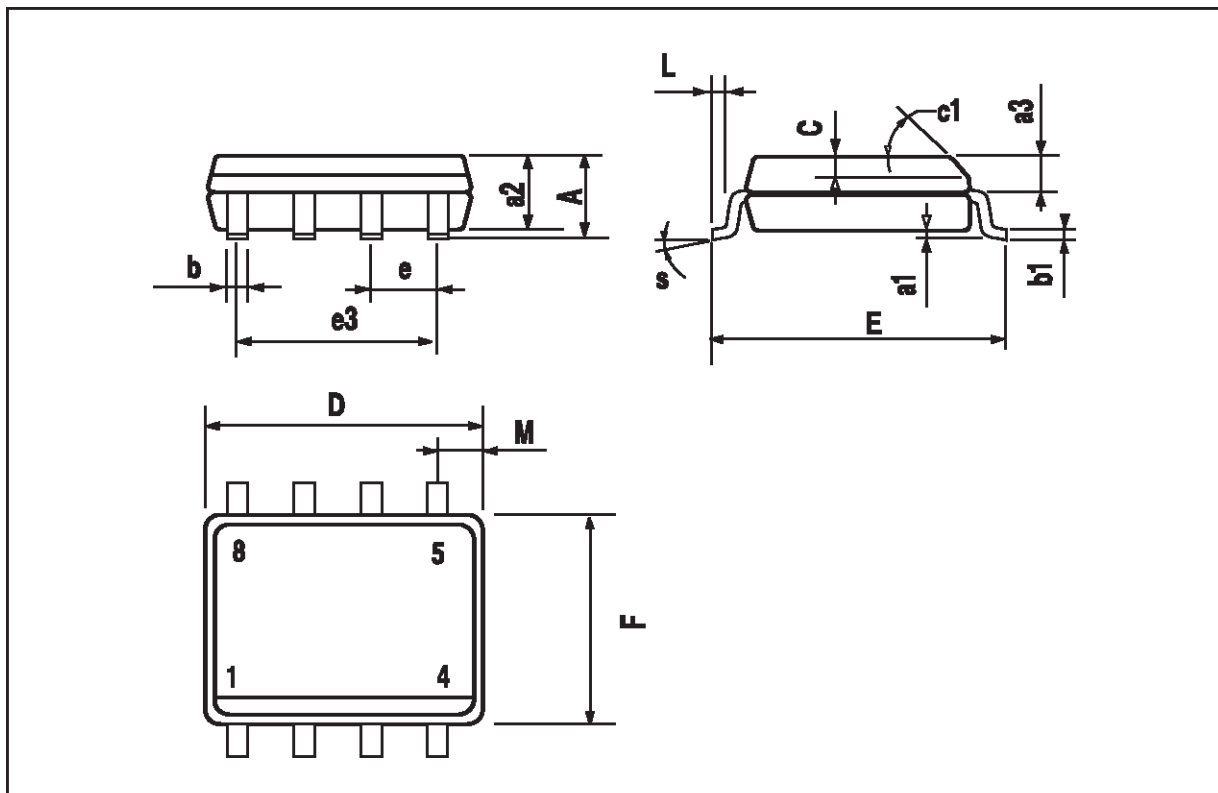



Information furnished is believed to be accurate and reliable. However, STMicroelectronics assumes no responsibility for the consequences of use of such information nor for any infringement of patents or other rights of third parties which may result from its use. No license is granted by implication or otherwise under any patent or patent rights of STMicroelectronics. Specification mentioned in this publication are subject to change without notice. This publication supersedes and replaces all information previously supplied. STMicroelectronics products are not authorized for use as critical components in life support devices or systems without express written approval of STMicroelectronics.

The ST logo is a registered trademark of STMicroelectronics

© 1999 STMicroelectronics – Printed in Italy – All Rights Reserved

STMicroelectronics GROUP OF COMPANIES

Australia - Brazil - Canada - China - France - Germany - Italy - Japan - Korea - Malaysia - Malta - Mexico - Morocco - The Netherlands - Singapore - Spain - Sweden - Switzerland - Taiwan - Thailand - United Kingdom - U.S.A.

<http://www.st.com>