

Mixer and Oscillator for TV Tuner

DESCRIPTION

The NJM2540/43 are mixer/oscillator especially designed for TV tuners and consists of mixers, oscillators, IF amplifier and OSC buffer for VHF,UHF and CATV band, built into one chip.

The NJM2540/43 packaging in SSOP16 are suitable for small-sized tuners.

The NJM2543 is the reverse pin assignment type of the NJM2540.

PACKAGE OUTLINE

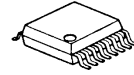

NJM2540V/NJM2543V

FEATURES

- Operating Voltage 5V
- Mixers, Oscillators, IF AMP and OSC buffer on chip
- Bipolar Technology
- Package Outline: SSOP16

BLOCK DIAGRAM

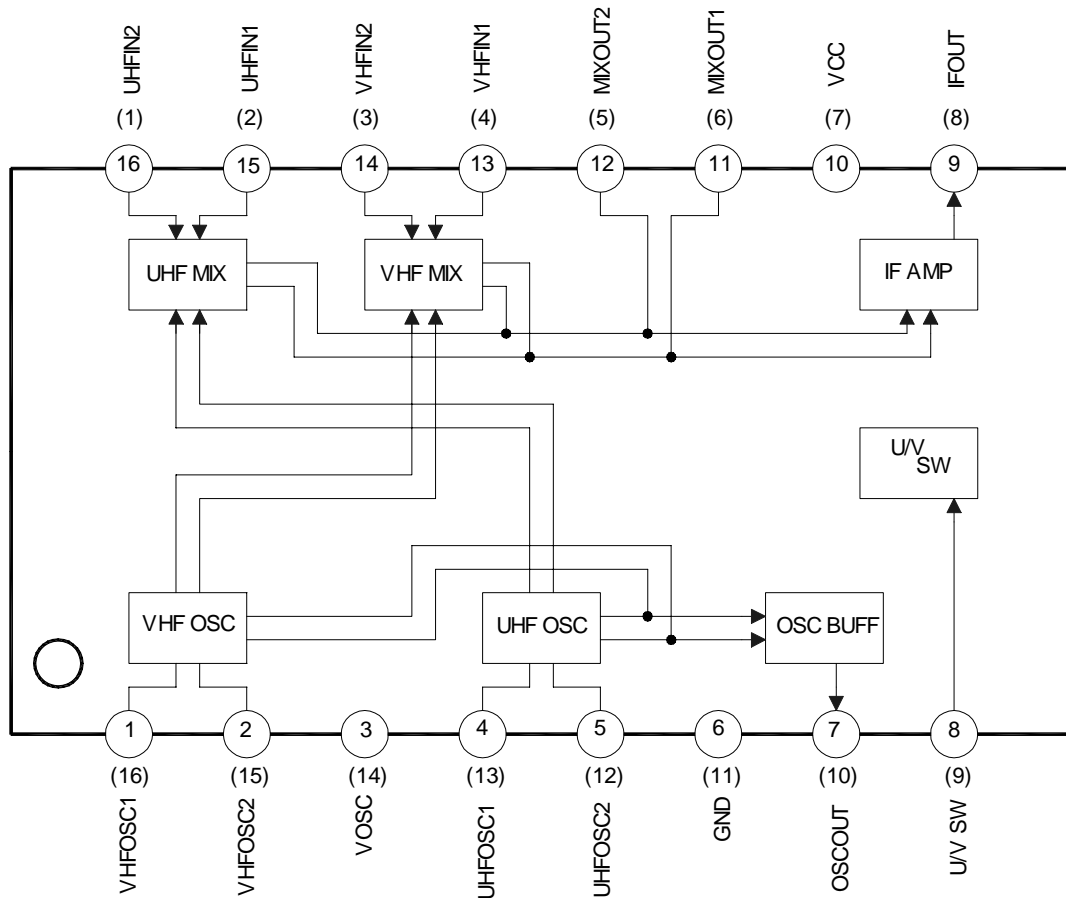

(Note)

Pin numbers in circle are for NJM2540

Pin numbers in parenthesis are for NJM2543

NJM2540/2543

■ ABSOLUTE MAXIMUM RATINGS

($T_A=25^\circ\text{C}$)

Parameter	Symbol	Ratings	Unit
Supply Voltage	V _{cc}	7	V
Power Dissipation	P _D	*550	mW
Operating Temperature Range	T _{opr}	-20 to +75	°C
Storage Temperature Range	T _{stg}	-40 to +150	°C

* Test IC soldered on PC board

■ RECOMMENDED OPERATING VOLTAGE RANGE

($T_A=25^\circ\text{C}$)

Parameter	Condition	Symbol	Min.	Typ.	Max.	Unit
Operating Voltage		V _{cc}	4.5	5.0	5.5	V

■ ELECTRICAL CHARACTERISTICS (Note 1)

(V_{cc}=5V, $T_A=25^\circ\text{C}$, IF=45.75MHz)

Parameter	Condition	Symbol	Min.	Typ.	Max.	Unit
Operating Current	VHF OSC only, No RF input	I _{cc1}	24	41	56	mA
Operating Current	UHF OSC only, No RF input	I _{cc2}	25	42	57	mA
Conversion Gain	VHF OSC only f _{RF} =55.25 to 361.25MHz, -50dBm	Ga1	-	26	-	dB
Conversion Gain	VHF OSC only f _{RF} =55.25 to 361.25MHz, -50dBm	Ga2	-	30	-	dB
PCS Beat 1	VHF OSC only Input Level: F _p =F _c =F _s IF Output level: -10dBm	PCS1	-	51	-	dB
PCS Beat 2	UHF OSC only Input Level: F _p =F _c =F _s IF Output level: -10dBm	PCS2	-	50	-	dB
Noise Figure 1	VHF OSC only F _{RF} =55.25 to 361.25MHz	NF1	-	13	-	dB
Noise Figure 2	VHF OSC only F _{RF} =55.25 to 361.25MHz	NF2	-	11	-	dB
OSC Output Level	F _{local} =101 to 847MHz	OUTosc	-	-12	-	dBm
Maximum IF Output Level	F _{local} =55.25 to 801.25MHz	OUTif	-	10	-	dBm

(Note 1) Because AC characteristics largely depends on application circuit, these parameters are specified by the DC characteristics as shown in next page.

■ DC ELECTRICAL CHARACTERISTICS ($V_{CC}=V_{osc}=V_{mix}=5V, T_A=25^{\circ}C, V_b=2.92V$)

Parameter	Condition	Symbol	Min.	Typ.	Max.	Unit
Pin3 Current 1:UHF	$V_{sw}=2v$	I_{osc1}	9	-	17.6	mA
Pin3 Current 2:VHF	$V_{sw}=0.5v$	I_{osc2}	8.7	-	16.8	mA
Pin7 Voltage 1:UHF	$V_{sw}=2v$	$V_{oscout1}$	3.45	-	3.95	V
Pin7 Voltage 2:VHF	$V_{sw}=0.5v$	$V_{oscout2}$	3.45	-	3.95	V
Pin9 Voltage	$V_{sw}=2v$	V_{ifout}	2	-	2.5	V
Pin10 Current	$V_{sw}=2v$	I_{cc}	18.5	-	37.5	mA
Pin11 Voltage 1:UHF	$V_{sw}=2v$	$V_{mixouta1}$	3.6	-	4.15	V
Pin11 Voltage 2:VHF	$V_{sw}=0.5v$	$V_{mixouta2}$	3.6	-	4.15	V
Pin12 Voltage 1:UHF	$V_{sw}=2v$	$V_{mixoutb1}$	3.6	-	4.15	V
Pin12 Voltage 2:VHF	$V_{sw}=0.5v$	$V_{mixoutb2}$	3.6	-	4.15	V
Pin1 Voltage	$V_{sw}=0.5v$	V_{vosc1}	2.65	-	3.2	V
Pin2 Voltage	$V_{sw}=0.5v$	V_{vosc2}	1.95	-	2.5	V
Pin4 Voltage	$V_{sw}=2v$	V_{uosc1}	1.95	-	2.45	V
Pin5 Voltage	$V_{sw}=2v$	V_{uosc2}	2.6	-	3.2	V
Pin2 Current	$V_{sw}=0.5v, 2Pin=V_{vosc1}, 1-2Pin Short$	I_{vosc}	2.4	-	4.6	mA
Pin4 Current	$V_{sw}=2v, 4Pin=V_{uosc1}, 4-5Pin Short$	I_{uosc}	2.9	-	5.7	mA
Pin13 Voltage	$V_{sw}=0.5v$	V_{vmixa}	1.8	-	2.25	V
Pin14 Voltage	$V_{sw}=0.5v$	V_{vmixb}	1.8	-	2.25	V
Pin15 Voltage	$V_{sw}=2v$	V_{umixa}	1.8	-	2.25	V
Pin16 Voltage	$V_{sw}=2v$	V_{umixb}	1.8	-	2.25	V

■ DC TEST CIRCUIT

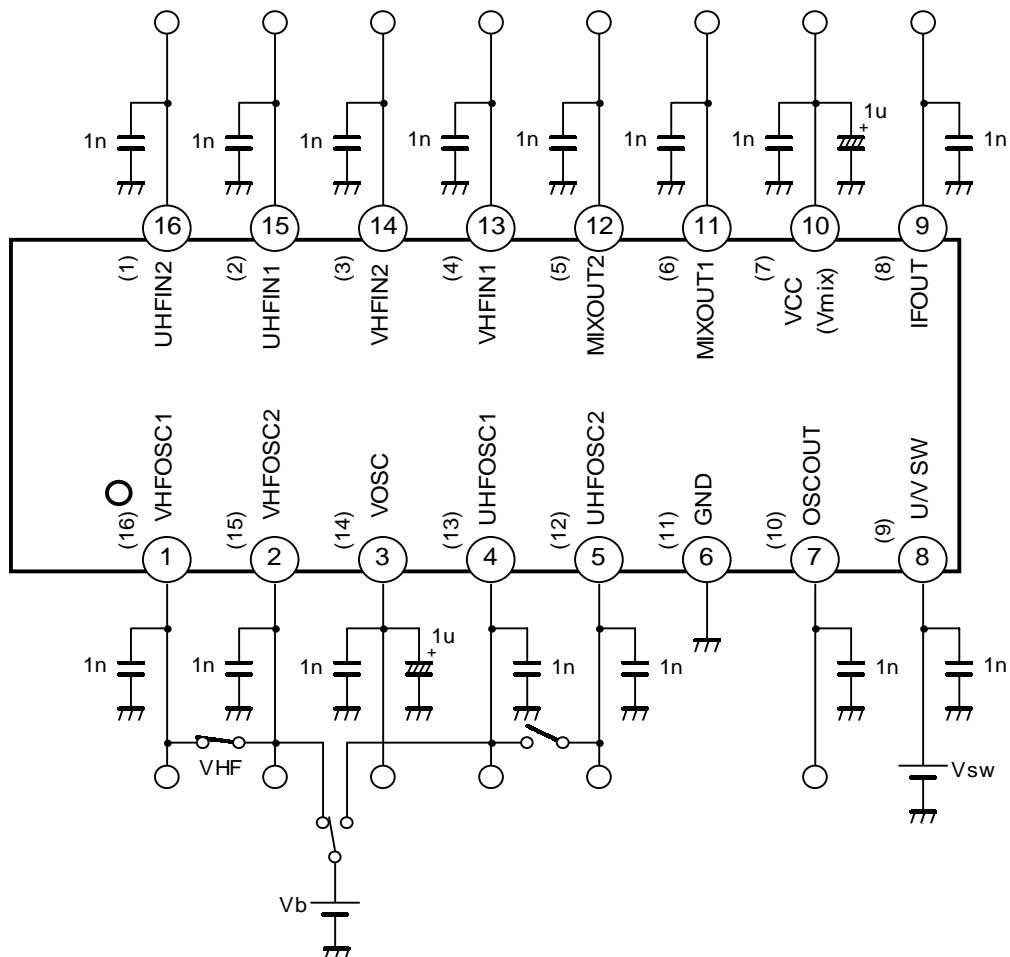

NJM2540/2543

■ AC TEST CIRCUIT

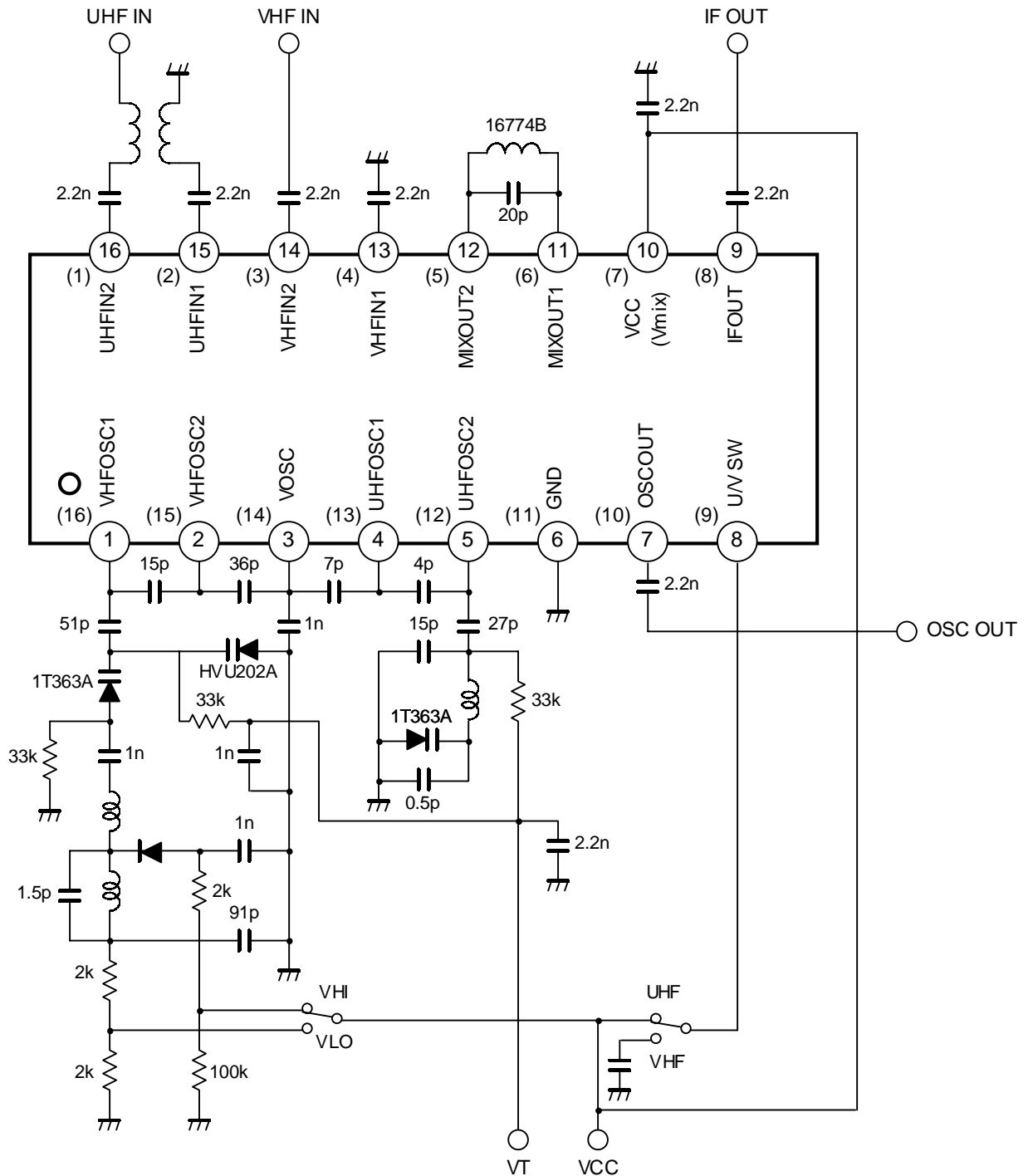

■ TERMINAL CHARACTERISTICS

No.	Symbol	Typ.DC Voltage (V)	Equivalent Circuit	Function
1 (16)	VHFOSC1	VHF 2.9		VHF Oscillator
2 (15)	VHFOSC2	VHF 2.2		
3 (14)	VOSC	-		Oscillator Power Supply
4 (13)	UHFOSC1	UHF 2.1		UHF Oscillator
5 (12)	UHFOSC2	UHF 2.9		
6 (11)	GND	-		GND
7 (10)	OSCOUT	3.7		OSC Output
8 (9)	U/V SW	-		UHF/MHF Select Switch UHF at Vcc VHF at GND
9 (8)	IFOUT	2.2		IF Output

NJM2540/2543

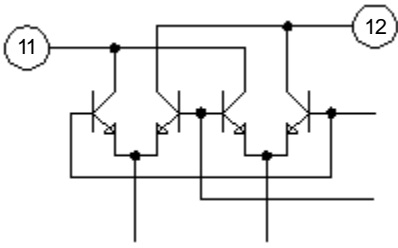
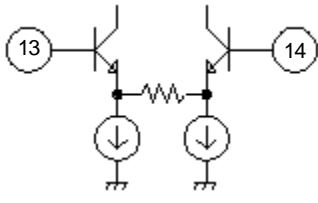
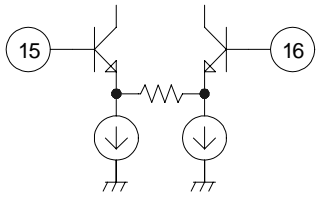
No.	Symbol	Typ.DC Voltage (V)	Equivalent Circuit	Function
10 (7)	VCC	-		Power Supply Except for Oscillator
11 (6)	MIXOUT1	3.9		Mixer Output
12 (5)	MIXOUT2	3.9		
13 (4)	VHFIN1	VHF 2.0		RF Input for VHF band
14 (3)	VHFIN2	VHF 2.0		
15 (2)	UHFIN1	UHF 2.0		RF Input for UHF band
16 (1)	UHFIN2	UHF 2.0		

TYPICAL CHARACTERISTICS

$V_{CC}=5V, f_{IF}=45.75MHz, T_A=25^{\circ}C$

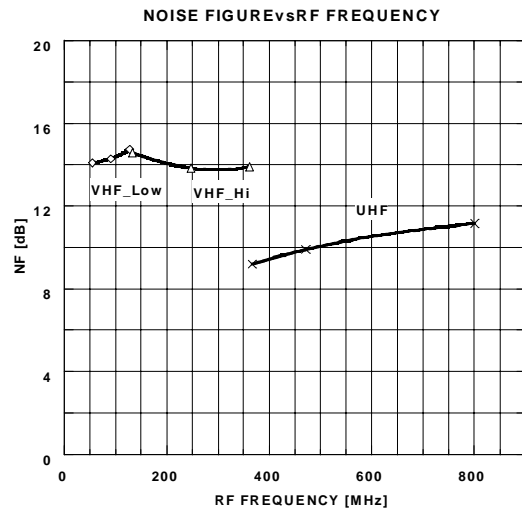
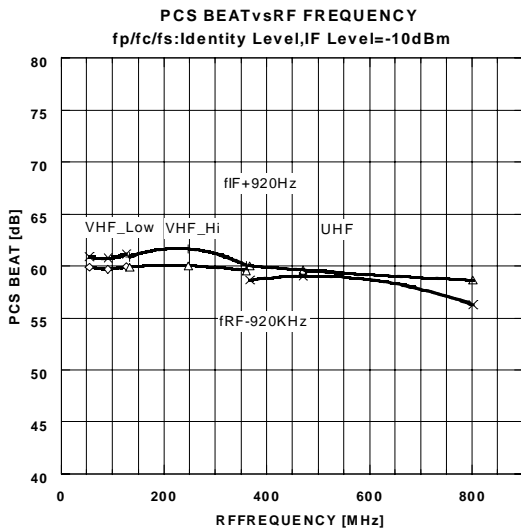
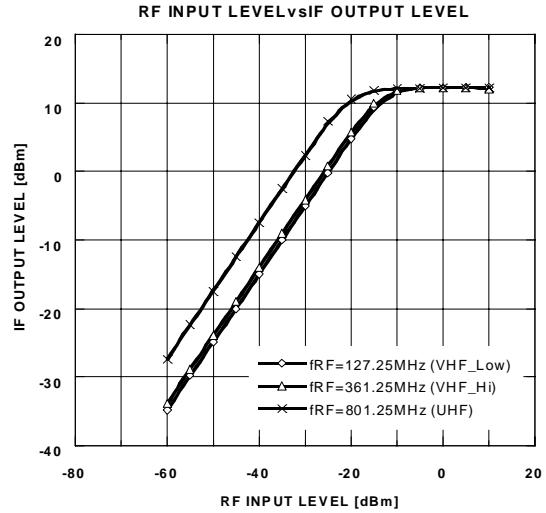
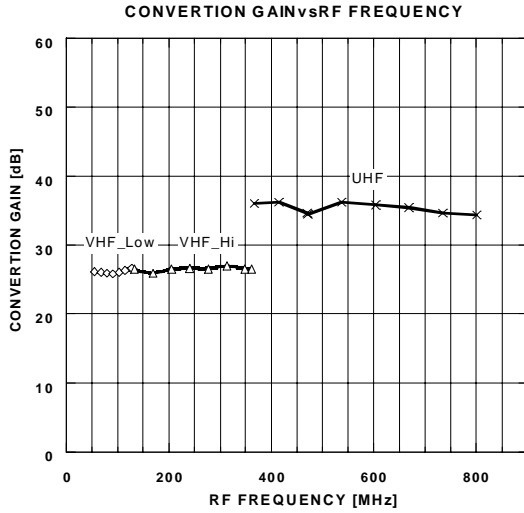

MEMO

[CAUTION]

The specifications on this databook are only given for information, without any guarantee as regards either mistakes or omissions. The application circuits in this databook are described only to show representative usages of the product and not intended for the guarantee or permission of any right including the industrial rights.