



NJM2568

Video Amplifier with 75 ohms Driver

GENERAL DESCRIPTION

THE NJM2568 is a video amplifier with 75 ohms drivers, which includes LPF and BPF of both Y and C system.

THE NJM2568 can compose the output circuit of digital video items with a little external components. It is suitable for portable items.

PACKAGE OUTLINE

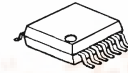

NJM2568V

FEATURES

- Operating Voltage $V^+1=4.5$ to $5.3V$, $V^+2=2.7$ to $5.3V$
- Operating Current $9.5mA_{typ}$, $V^+=4.8V$
 $7.3mA_{typ}$, $V^+=3.0V$
- Internal LPF, BPF
- Internal Clamp Discharge
- Bipolar Technology
- Package Outline SSOP14

BLOCK DIAGRAM

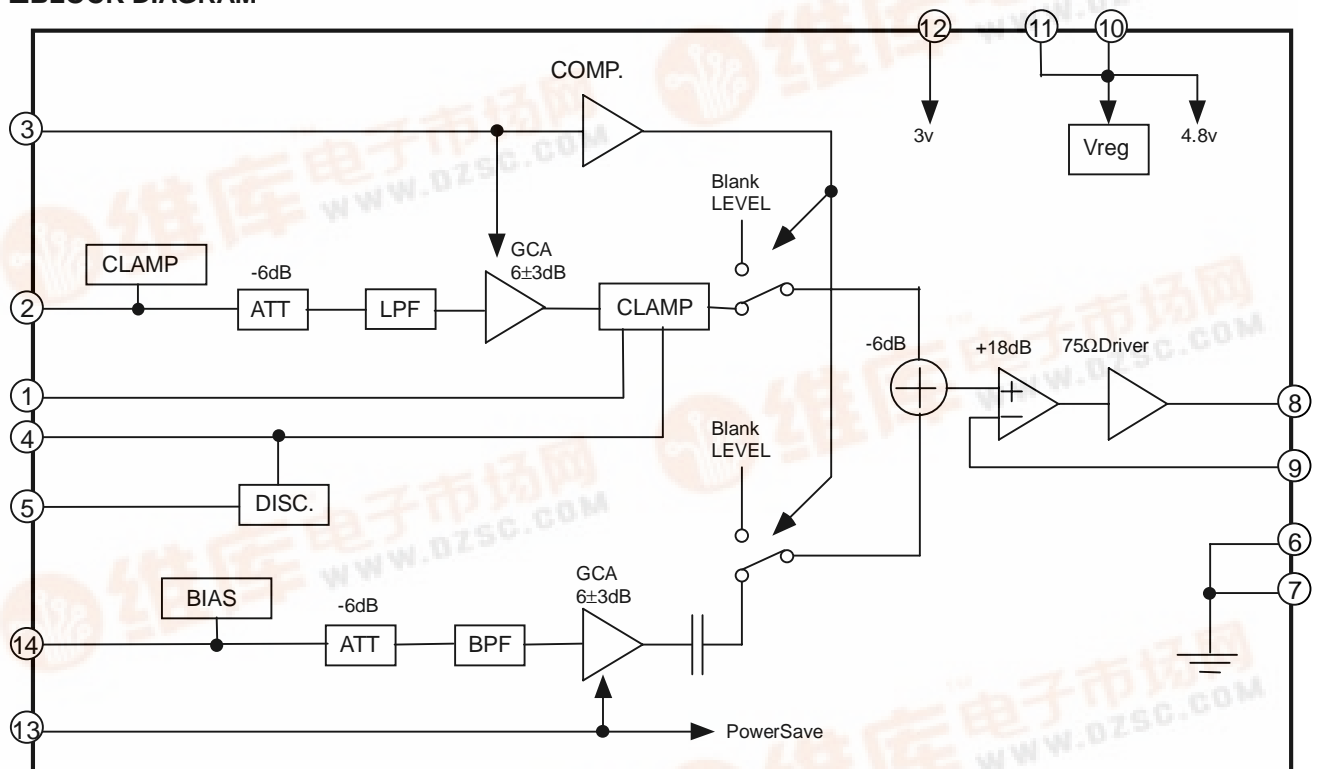

- | | |
|------------------|-------------------------|
| 1. CLAMP REF | 8. V_{SAG} |
| 2. Y_{IN} | 9. V_{OUT} |
| 3. GCA CTLY/MUTE | 10. V^+1 |
| 4. CLAMP | 11. V^+1 |
| 5. DIS CTL | 12. V^+2 |
| 6. GND | 13. GCA CTLC/POWER SAVE |
| 7. GND | 14. C_{IN} |



■ABSOLUTE MAXIMUM RATINGS

(Ta=25°C)

PARAMETERS	SYMBOL	RATINGS	UNIT
Supply Voltage	V ⁺	7.0	V
Power Dissipation	P _D	300	mW
Operating Temperature Range	T _{opr}	-20 to +85	°C
Storage Temperature Range	T _{stg}	-40 to +125	°C

■ELECTRICAL CHARACTERISTICS (Ta=25°C, V⁺1=4.8V, V⁺2=3.0V, R_L=150Ω)

PARAMETERS	SYMBOL	TEST CONDITION	MIN.	TYP.	MAX.	UNIT
Operating Current 1	I _{CC1}	V ⁺ 1=4.8V, No Signal	-	9.5	12.5	mA
Operating Current 1 (Power Save Mode)	I _{save1}	V ⁺ 1=4.8V, Power Save	-	1.6	2.1	mA
Operating Current 2	I _{CC2}	V ⁺ 2=3.0V, No Signal	-	7.3	10.0	mA
Operating Current 2 (Power Save Mode)	I _{save2}	V ⁺ 2=3.0V, Power Save	-	0.37	0.9	mA

(Y Amplifier)

Voltage Gain 1	G _{VY1}	V _{IN} to V _{OUT} , GCACTLY=0.5V 100kHz, 0.5Vp-p @Sine Wave	+3.0	+6.0	+9.0	dB
Voltage Gain 2	G _{VY2}	V _{IN} to V _{OUT} , GCACTLY=2.5V 100kHz, 0.5Vp-p @Sine Wave	+13.0	+16.0	+19.0	dB

(C Amplifier)

Voltage Gain 1	G _{VC1}	C _{IN} to V _{OUT} , GCACTLY=0.5V 4MHz, 143mVp-p @Sine Wave	+3.0	+6.0	+9.0	dB
Voltage Gain 2	G _{VC2}	C _{IN} to V _{OUT} , GCACTLC=2.5V 4MHz, 143mVp-p @Sine Wave	+13.0	+16.0	+19.0	dB

(Filter Characteristics)

LPF (Y _{IN})	G _{fY6M}	6MHz/100kHz, 100mVp-p @Sine Wave	-1.0	0	-	dB
	G _{fY7.2M}	7.2MHz/100kHz, 100mVp-p @Sine Wave	-1.5	0	-	dB
	G _{fY20M}	20MHz/100kHz, 100mVp-p @Sine Wave	-	-30	-20	dB
	DL _Y	Group Delay GD3MHz-GD6MHz	-	60	100	nsec
BPF (C _{IN})	G _{fC±1M}	±1MHz/4MHz, 100mV @Sine Wave	-1.0	0	-	dB
	G _{fC±1.6M}	±1.6MHz/4MHz, 100mV @Sine Wave	-3.0	0	-	dB
	G _{fC500k}	500kHz/4MHz, 100mVp-p @Sine Wave	-	-15	-10	dB
	G _{fC20M}	20MHz/4MHz, 100mVp-p @Sine Wave	-	-25	-10	dB
	DL _C	Group Delay GD3MHz-GD6MHz	-	60	90	nsec

(YC Delay)

YC Delay	T _{YC}	T _{YOUT} -T _{COOUT} at 4MHz	-	+25	-	nsec
----------	-----------------	---	---	-----	---	------

(Maximum Output Swing)

V-OUT	V _{OVm}	100kHz, Sine Wave, R _L =75Ω	1.2	-	-	Vp-p
-------	------------------	--	-----	---	---	------

(GCA Control Signal)

GCACTLY	V _{GC1}	GCA Control Voltage	0.5	-	2.5	V
	V _{GL1}	MUTE Voltage	GND	-	0.3	V
GCACTLC	V _{GC2}	GCA Control Voltage	0.5	-	2.5	V
	V _{GL2}	Power Down Voltage	GND	-	0.3	V

■TEST CIRCUIT

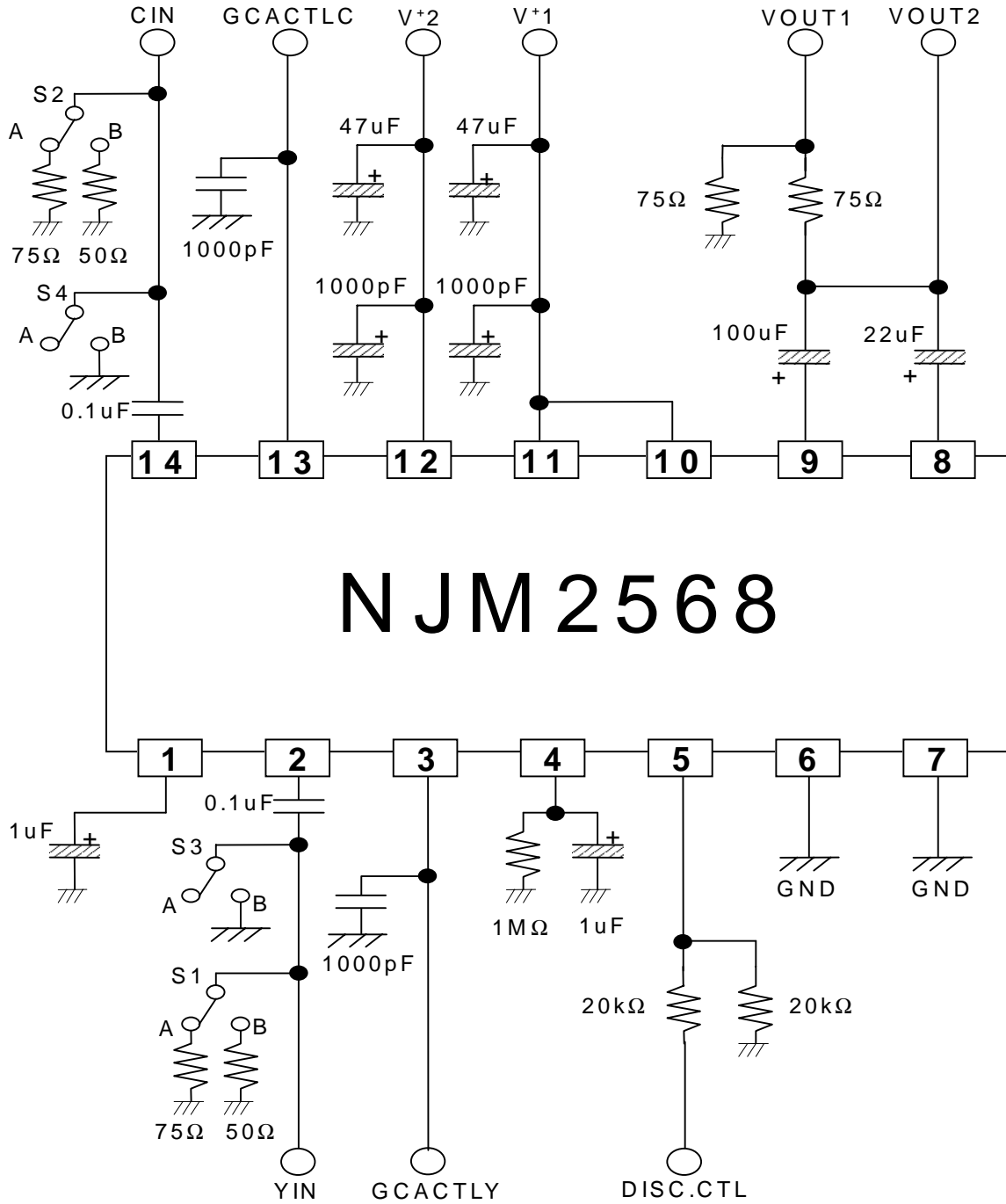

NJM2568

MEMO

<注意事項>

このデータブックの掲載内容の正確さには万全を期しておりますが、掲載内容について何らかの法的な保証を行うものではありません。とくに応用回路については、製品の代表的な応用例を説明するためのものです。また、工業所有権その他の権利の実施権の許諾を伴うものではなく、第三者の権利を侵害しないことを保証するものでもありません。