

3rd. Over Tone Quartz Crystal Oscillator for 166MHz

■GENERAL DESCRIPTION

The NJU6396 is a C-MOS IC for XO's, and can oscillate up to 166MHz maximum at very low operating voltage.

High Fan-out is gained from low operating voltage with 3-state output buffer and the oscillation amplifier that is realized very low stand-by current using NAND circuit.

Furthermore, not using PLL, the electrical character shows a very low jitter.

The NJU6396 is suitable for mobile, optical communications (included WDM system) and not to mention previous applications; Computer & Peripherals, telecommunications, LAN/WAN, Wireless and so on.

■PACKAGE OUTLINE



NJU6396C-D

■FEATURES

- Operating Voltage 2.7 to 3.6V
- Maximum Oscillation Frequency 166MHz
- High Fan-out $I_{OH}/I_{OL}=8mA @3.3V$
- Oscillation Stop and Output Stand-by Function
- 3-State Output Buffer
- Oscillation Capacitors C_g and C_d on-chip
- Package Outline Thin-Chip
- C-MOS Technology

■PAD LACATION

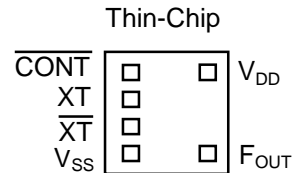

■PAD CONFIGURATION

No	Pad Name	X	Y
1	\overline{CONT}	-178	231
2	XT	-178	77
3	\overline{XT}	-178	-77
4	V_{SS}	-178	-231
5	F_{OUT}	206	-231
8	V_{DD}	206	231

Starting Point:Chip Center Unit[um]
 Chip Size:0.7x0.75mm
 Thin-Chip Thickness:200±20um
 Pad Size:90x90um

■BLOCK DIAGRAM

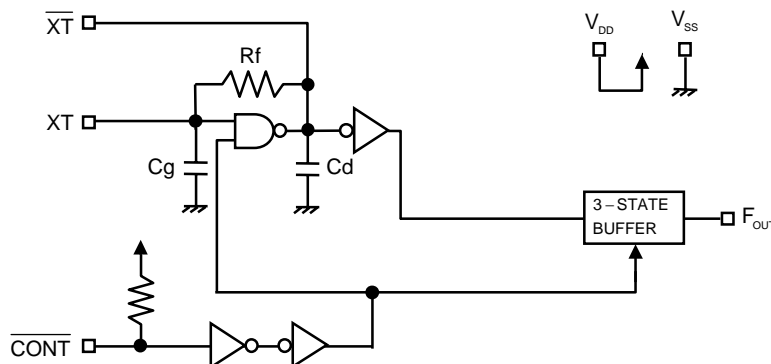

■TERMINAL DESCRIPTION

SYMBOL	FUNCTION	
$\overline{\text{CONT}}$	Oscillation and 3-state Output Buffer Control	
	$\overline{\text{CONT}}$	F_{OUT}
	H or OPEN	Output frequency f_0
	L	Oscillation Stop and High impedance Output
$\overline{\text{XT}}$	Quartz Crystal Connecting Terminals	
V_{SS}	$V_{\text{SS}}=0\text{V}$	
F_{OUT}	Frequency Output	
V_{DD}	$V_{\text{DD}}=3.3\text{V}$	

■ABSOLUTE MAXIMUM RATINGS

(Ta=25°C)

PARAMETER	SYMBOL	RATING	UNIT
Supply Voltage	V_{DD}	-0.5 to +7.0	V
Input Voltage	V_{IN}	$V_{\text{SS}}-0.5$ to $V_{\text{DD}}+0.5$	V
Output Voltage	V_{O}	-0.5 to $V_{\text{DD}}+0.5$	V
Input Current	I_{IN}	± 10	mA
Output Current	I_{O}	± 25	mA
Operating Temperature Range	Topr	-40 to +85	°C
Storage Temperature Range	Tstg	-55 to +125	°C

 Note1) If the supply voltage(V_{DD}) is less than 7.0V, the input voltage do not over the V_{DD} level.

 Note2) Decoupling capacitor should be connected between V_{DD} and V_{SS} due to the stabilized operation for the circuit.

■ELECTRICAL CHARACTERISTICS

(Ta=25°C)

PARAMETER	SYMBOL	CONDITIONS	MIN	TYP	MAX	UNIT
Operating Voltage	V _{DD}		2.7		3.6	V

 (V_{DD}=3.3V, Ta=25°C)

PARAMETER	SYMBOL	CONDITIONS	MIN	TYP	MAX	UNIT
Operating Current	I _{DD1}	fosc=166MHz, C _L =15pF		27	40	mA
Oscillation Stopping Current	I _{DD2}	$\overline{\text{CONT}} = V_{SS}$, No load			10	uA
Stand-by Current	I _{st}	$\overline{\text{CONT}} = \text{XT} = V_{SS}$, No load Note3)			1	uA
Input Voltage	V _{IH}		2.31		3.3	V
	V _{IL}		0		0.99	V
Output Current	I _{OH}	V _{OH} =2.97V	8			mA
	I _{OL}	V _{OL} =0.33V	8			mA
Input Current	I _{IN}	$\overline{\text{CONT}} = 0.8V_{DD}$		10.0	15.0	uA
		$\overline{\text{CONT}} = 0.2V_{DD}$		1.8	3.0	uA
3-state Off Leakage Current	I _{OZ}	$\overline{\text{CONT}} = V_{SS}$, F _{OUT} = V _{DD} or V _{SS}			±0.1	uA
Internal Capacitor	Cg/Cd	fosc=166MHz		9/10		pF
Maximum Oscillation Frequency	F _{MAX}		166			MHz
Output Signal Symmetry	SYM	C _L =15pF, @V _{DD} /2	45	50	55	%
Output Signal Rise Time	tr	C _L =15pF, 10% to 90%		2	3	ns
Output Signal Fall Time	tf	C _L =15pF, 90% to 10%		2	3	ns
Output Disable time	T _{PLZ}	C _L =15pF, R _{UP} =10kΩ			150	ns
Output Enable Time	T _{PZL}	C _L =15pF, R _{UP} =10kΩ			150	ns

 Note3) Excluding input current on $\overline{\text{CONT}}$ Terminal.

MEASUREMENT CIRCUITS

(1) Output Signal Symmetry ($C_L=15\text{pF}$)

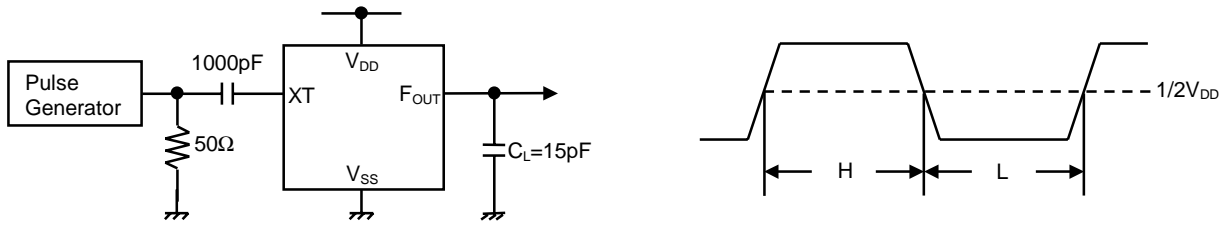

(2) Output Signal Rise/Fall Time ($C_L=15\text{pF}$)

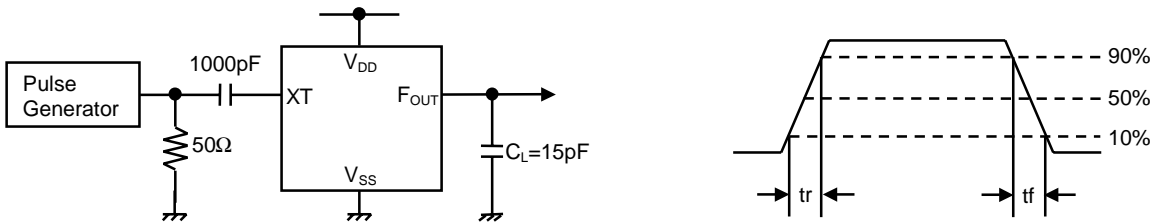

(3) Output Disable/Enable Time ($C_L=15\text{pF}, R_{UP}=10\text{k}\Omega$)

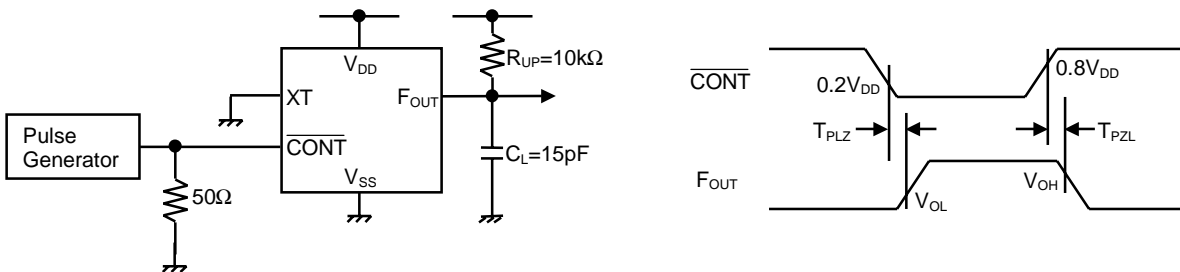

[CAUTION]
 The specifications on this data book are only given for information, without any guarantee as regards either mistakes or omissions. The application circuits in this data book are described only to show representative usages of the product and not intended for the guarantee or permission of any right including the industrial rights.