



8-Channel, 12-Bit, 70MSPS ADC with Serialized LVDS Interface

FEATURES

- Maximum Sample Rate: 70MSPS
- 12-Bit Resolution
- No Missing Codes
- Power Dissipation: 1.1W
- CMOS Technology
- Simultaneous Sample-and-Hold
- 70.5dB SNR at 10MHz IF
- Serialized LVDS Outputs Meet or Exceed the Requirements of ANSI TIA/EIA-644-A Standard
- Internal and External References
- 3.3V Digital/Analog Supply
- TQFP-80 PowerPAD™ Package

APPLICATIONS

- Portable Ultrasound Systems
- Tape Drives
- Test Equipment

DESCRIPTION

The ADS5273 is a high-performance, 70MSPS, 8-channel parallel analog-to-digital converter (ADC). An internal reference is provided, simplifying system design requirements. Low power consumption allows for the highest of system integration densities. Serial LVDS outputs reduce the number of interface lines and package size.

In LVDS (low-voltage differential signaling), an integrated phase lock loop multiplies the incoming ADC sampling clock by a factor of 6. This high-frequency LVDS clock is used in the data serialization and transmission process and is converted to an LVDS signal for transmission in parallel with the data. Providing this additional LVDS clock allows for easy delay matching. The word output of each internal ADC is serialized and transmitted either MSB or LSB first. The bit following the rising edge of the ADC clock output is the first bit of the word.

The ADS5273 provides an internal reference, or can optionally be driven with an external reference. Best performance can be achieved through the internal reference mode.

The device is available in a PowerPAD TQFP-80 package and is specified over a -40°C to $+85^{\circ}\text{C}$ operating range.

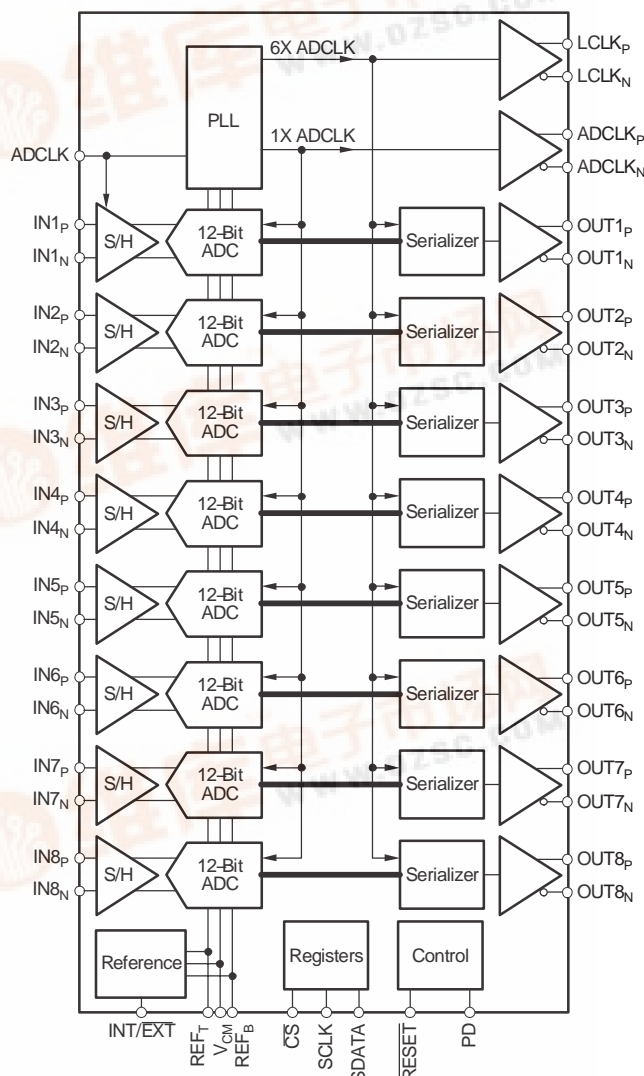

PRODUCT PREVIEW

ABSOLUTE MAXIMUM RATINGS(1)

Supply Voltage Range, AVDD	-0.3V to 3.8V
Supply Voltage Range, LVDD	-0.3V to 3.8V
Voltage Between AVSS and LVSS	-0.3V to 0.3V
Voltage Between AVDD and LVDD	-0.3V to 0.3V
Voltagess Applied to External REF Pins	-0.3V to 2.4V
All LVDS Data and Clock Outputs	-0.3V to 2.4V
ADCLK Peak Input Current	TBD
Peak Total Input Current (all inputs)	-30mA
Operating Free-Air Temperature Range, T _A	-40°C to 85°C
Lead Temperature 1.6mm (1/16" from case for 10s)	235°C



This integrated circuit can be damaged by ESD. Texas Instruments recommends that all integrated circuits be handled with appropriate precautions. Failure to observe proper handling and installation procedures can cause damage.

ESD damage can range from subtle performance degradation to complete device failure. Precision integrated circuits may be more susceptible to damage because very small parametric changes could cause the device not to meet its published specifications.

(1) Stresses above these ratings may cause permanent damage. Exposure to absolute maximum conditions for extended periods may degrade device reliability. These are stress ratings only, and functional operation of the device at these or any other conditions beyond those specified is not supported.

ORDERING INFORMATION

PRODUCT	PACKAGE-LEAD	PACKAGE DESIGNATOR(1)	SPECIFIED TEMPERATURE RANGE	PACKAGE MARKING	ORDERING NUMBER	TRANSPORT MEDIA, QUANTITY
ADS5273	HTQFP-80	PFP	-40°C to +85°C	ADS5273IPFP	ADS5273IPFP	Tray, 96
"	"	"	"	"	ADS5273IPFPT	Tape and Reel, 250

(1) For the most current specification and package information, refer to our web site at www.ti.com.

RECOMMENDED OPERATING CONDITIONS

	ADS5273			UNIT
	MIN	TYP	MAX	
SUPPLIES AND REFERENCES				
Analog Supply Voltage, AVDD	3.0	3.3	3.6	V
Output Driver Supply Voltage, LVDD	3.0	3.3	3.6	V
CLOCK INPUT AND OUTPUTS				
ADCLK Input Sample Rate (low-voltage TTL), 1/t _C	20		70	MSPS
Low Voltage Level Clock			1	V
High Voltage Level Clock			2	V
ADCLK _P and ADCLK _N Outputs (LVDS)	35		70	MHz
LCLK _P and LCLK _N Outputs (LVDS)(1)	210		420	MHz
Operating Free-Air Temperature, T _A	-40		+85	°C

(1) 6 × ADCLK.

REFERENCE SELECTION

MODE	INT/EXT	DESCRIPTION
2.0V _{pp} Internal Reference	1	Default with internal pull-up.
External Reference	0	Internal reference is powered down. Common mode of external reference should be within 50mV of V _{CM} . V _{CM} is derived from the internal bandgap voltage.

PRODUCT PREVIEW

ELECTRICAL CHARACTERISTICS

$T_{MIN} = -40^{\circ}\text{C}$, and $T_{MAX} = +85^{\circ}\text{C}$. Typical values are at $T_A = 25^{\circ}\text{C}$, clock frequency = maximum specified, 50% clock duty cycle, $AV_{DD} = 3.3\text{V}$, $LV_{DD} = 3.3\text{V}$, -0.5dBFS , internal voltage reference, and LVDS buffer current at 3.5mA per channel, unless otherwise noted.

PARAMETER	TEST CONDITIONS	ADS5273			UNITS
		MIN	TYP	MAX	
DC ACCURACY					
No Missing Codes			Assured		
DNL Differential Nonlinearity		TBD	0.5	TBD	LSB
INL Integral Nonlinearity		TBD	1	TBD	LSB
Midscale Offset Error ⁽¹⁾		TBD		TBD	mV
Offset Temperature Coefficient			TBD		ppm/ $^{\circ}\text{C}$
Fixed Gain Error ⁽²⁾		TBD	1.0	TBD	%FS
Gain Temperature Coefficient			TBD		$\Delta\%/^{\circ}\text{C}$
POWER SUPPLY					
I_{CC} Total Supply Current	$V_{IN} = FS, F_{IN} = 10\text{MHz}$		333		mA
$I(AV_{DD})$ Analog Supply Current	$V_{IN} = FS, F_{IN} = 10\text{MHz}$		289		mA
$I(LV_{DD})$ Digital Output Driver Supply Current	$V_{IN} = FS, F_{IN} = 10\text{MHz}$, LVDS Into 100 Ω Load		44		mA
Power Dissipation	$V_{IN} = FS, F_{IN} = 10\text{MHz}$		1.1		W
REFERENCE VOLTAGES					
V_{REF_T} Reference Top (internal)			2.0		V
V_{REF_N} Reference Bottom (internal)			1.0		V
V_{CM} Common-Mode Voltage			1.5		V
V_{CM} Output Current			TBD		mA
V_{REF_T} Reference Top (external)		1.875			V
V_{REF_B} Reference Bottom (external)				1.125	V
Reference Input Resistance ⁽³⁾			TBD		
ANALOG INPUT					
DC Differential Input Resistance			1.2		k Ω
Differential Input Capacitance			7		pF
Analog Input Common-Mode Range			$V_{CM} \pm 0.05$		V
Differential Input Voltage Range		1.5		2.0	V_{PP}
Voltage Overload Recovery Time	Differential Input Signal at 4V _{pp} Recovery to Within 1% of Code		4		CLK Cycles
Input Bandwidth	-3dBFS		300		MHz
DIGITAL DATA OUTPUTS					
Data Bit Rate		420		840	MBPS
SERIAL INTERFACE					
SCLK Serial Clock Input Frequency				20	MHz
$V_{IN\ LOW}$ Input Low Voltage		0		0.6	V
$V_{IN\ HIGH}$ Input High Voltage		2.1		V _{DD}	V
Input Current			TBD		μA
Input Pin Capacitance			5		pF

(1) Offset Error is the measured deviation of the midscale transition from the ideal midscale transition.

(2) Gain Error is the difference between the nominal and actual offset point on the transfer function after the offset error has been corrected to zero. The gain point is the mid-step value when the digital output is full-scale.

(3) Average switching current drawn from external reference. DC component of current is internally generated even in external reference mode.

AC CHARACTERISTICS

T_{MIN} = -40°C, T_{MAX} = +85°C. Typical values are at T_A = 25°C, clock frequency = maximum specified, 50% clock duty cycle, AVDD = 3.3V, LVDD = 3.3V, -0.5dBFS, internal voltage reference, and 2V_{pp} differential input, unless otherwise noted.

PARAMETER	CONDITIONS	ADS5273			UNITS
		MIN	TYP	MAX	
DYNAMIC CHARACTERISTICS					
SFDR Spurious-Free Dynamic Range	f _{IN} = 1MHz	TBD	85		dBc
	f _{IN} = 5MHz		85		dBc
	f _{IN} = 10MHz		85		dBc
	f _{IN} = 20MHz		80		dBc
HD ₂ 2nd-Order Harmonic Distortion	f _{IN} = 1MHz	TBD	90		dBc
	f _{IN} = 5MHz		87		dBc
	f _{IN} = 10MHz		80		dBc
	f _{IN} = 20MHz		76		dBc
HD ₃ 3rd-Order Harmonic Distortion	f _{IN} = 1MHz	TBD	87		dBc
	f _{IN} = 5MHz		84		dBc
	f _{IN} = 10MHz		77		dBc
	f _{IN} = 20MHz		73		dBc
SNR Signal-to-Noise Ratio	f _{IN} = 1MHz	TBD	70.5		dBFS
	f _{IN} = 5MHz		70.5		dBFS
	f _{IN} = 10MHz		70.5		dBFS
	f _{IN} = 20MHz		70.5		dBFS
SINAD Signal-to-Noise and Distortion	f _{IN} = 1MHz	TBD	70		dBFS
	f _{IN} = 5MHz		70		dBFS
	f _{IN} = 10MHz		70		dBFS
	f _{IN} = 20MHz		70		dBFS
ENOB Effective Number of Bits	f _{IN} = 10MHz		11.3		Bits
Crosstalk	Signal Applied to 7 Channels; Measurement Taken on the Channel with No Input Signal		-85		dBc

LVDS DIGITAL DATA AND CLOCK OUTPUTS

Test conditions at I_O = 3.5mA, R_{LOAD} = 100Ω, and C_{LOAD} = 9pF. All LVDS specifications are characterized but not tested.

PARAMETER	CONDITIONS	MIN	TYP	MAX	UNITS
DC SPECIFICATIONS					
V _{OH} Output Voltage High, OUT _P or OUT _N	R _{LOAD} = 100Ω ± 1%; See LVDS Timing Diagram, Page 7		1340	1475	mV
V _{OL} Output Voltage Low, OUT _P or OUT _N	R _{LOAD} = 100Ω ± 1%	925	1038		mV
V _{OD} Output Differential Voltage	R _{LOAD} = 100Ω ± 1%	325	350	375	mV
V _{OS} Output Offset Voltage	R _{LOAD} = 100Ω ± 1%; See LVDS Timing Diagram, Page 7	1.125	1.250	1.275	V
R _O Output Impedance, Single-Ended	V _{CM} = 1.0V and 1.4V		TBD		Ω
ΔR _O Mismatch Between OUT _P and OUT _N	V _{CM} = 1.0V and 1.4V			TBD	%
C _O Output Capacitance	V _{CM} = 1.0V and 1.4V	3	4	5	pF
ΔV _{OD} Change in V _{OD} Between 0 and 1	R _{LOAD} = 100Ω ± 1%			25	mV
ΔV _{OS} Change Between 0 and 1	R _{LOAD} = 100Ω ± 1%			25	mV
ISOUT _P / ISOUT _N Output Short-Circuit Current	Drivers Shorted to Ground			40	mA
ISOUT _{NP} Output Current	Drivers Shorted Together			12	mA
I _{XN} / I _{XP} Power-Off Output Leakage	V _{CC} = 0V			10	mA
DRIVER AC SPECIFICATIONS					
Clock Clock Signal Duty Cycle	6 × ADCLK	45	50	55	%
t _{SKEW1} t _{pHLP} - t _{pLHN} or t _{pHLN} - t _{pLHP} Differential Skew	Any Differential Pair on Package(1)			50	ps
t _{SKEW2} t _{pDIFF[X]} - t _{pDIFF[Y]} Channel-to-Channel Skew(3)	Any Two Signals on Package(2)			100	ps
t _{RISE} /t _{FALL} V _{OD} Rise Time or V _{OD} Fall Time	Z _{LOAD} = 100Ω, C _I = 9pF, I _O = 2.5mA		400		
	Z _{LOAD} = 100Ω, C _I = 9pF, I _O = 3.5mA		250		ps
	Z _{LOAD} = 100Ω, C _I = 9pF, I _O = 4.5mA		200		ps
	Z _{LOAD} = 100Ω, C _I = 9pF, I _O = 6mA		150		ps

(1) Skew measurements are made at the 50% point of the transition.

(2) Skew measurements made at 0V differential (that is, the crossing of single-ended signals).

(3) Where x is any one of the parallel channels and y is any other channel.

SWITCHING CHARACTERISTICS

T_{MIN} = -40°C, T_{MAX} = +85°C. Typical values are at T_A = 25°C, clock frequency = maximum specified, 50% clock duty cycle, AVDD = 3.3V, LVDD = 3.3V, -0.5dBFS, internal voltage reference, and 2V_{pp} differential input, unless otherwise noted.

PARAMETER	CONDITIONS	MIN	TYP	MAX	UNITS
SWITCHING SPECIFICATIONS					
t _{SAMPLE}		14.3		50	ns
t _{D(A)} Aperture Delay			120		ps
Aperture Jitter (uncertainty)			1		ps
t _{D(pipeline)} Latency			6.5		cycles
t _{PROP} Propagation Delay			13		ns

SERIAL INTERFACE TIMING

Data is shifted in MSB first.

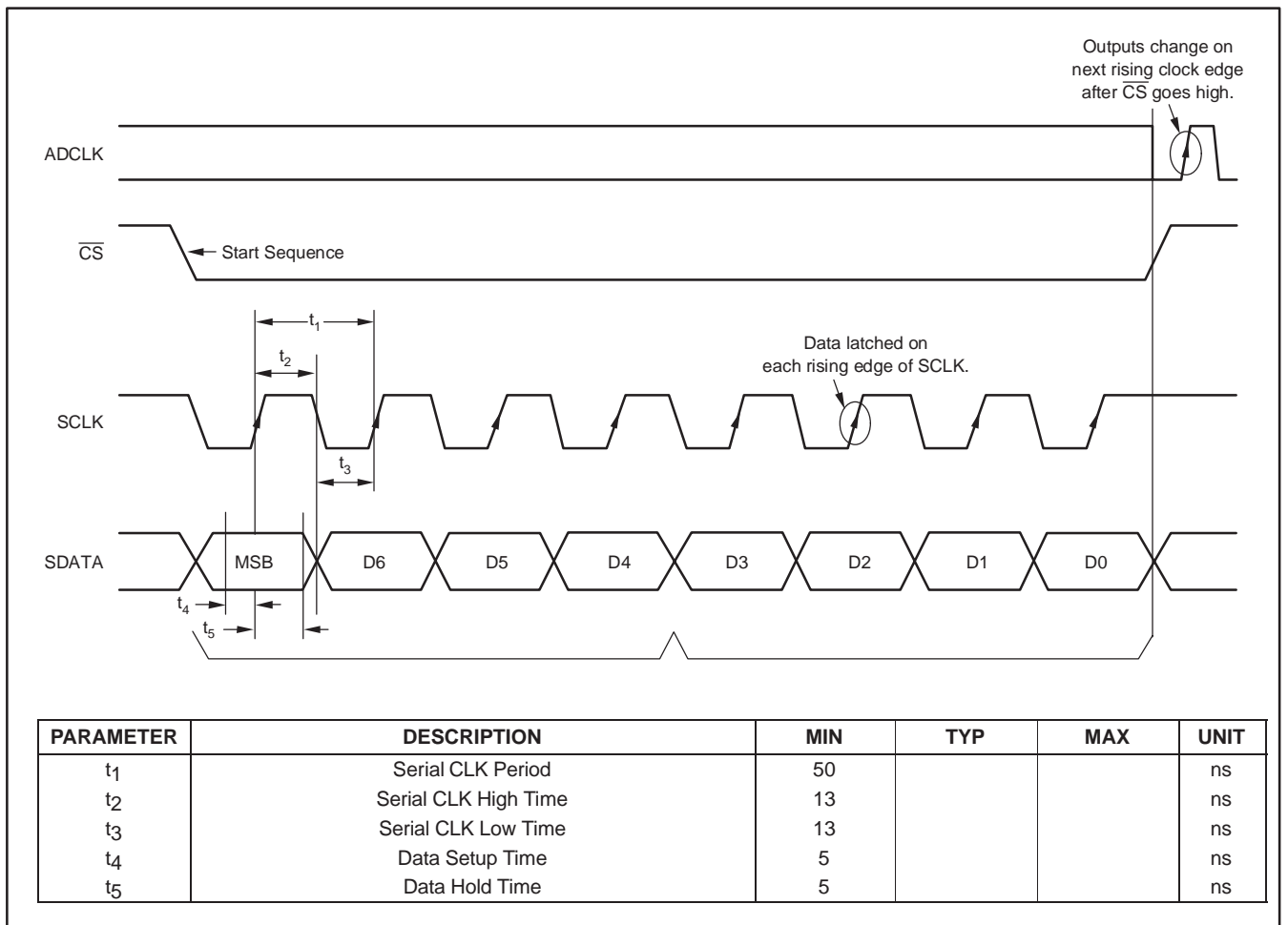

SERIAL INTERFACE TIMING

ADDRESS				DATA				DESCRIPTION	REMARKS
D7	D6	D5	D4	D3	D2	D1	D0		
0	0	0	0	0	0			0. LVDS BUFFERS Normal ADC Output Deskew Pattern Sync Pattern Custom Pattern Output Current in LVDS = 3.5mA Output Current in LVDS = 2.5mA Output Current in LVDS = 4.5mA Output Current in LVDS = 6.0mA	Patterns Get Reversed in MSB First Mode of LVDS
				0	1				
				1	0				
				1	1	0	0		
						0	1		
						1	0		
						1	1		
0	0	0	1	D3	D2	D1	D0	1. LSB/MSB MODE 2X LVDS Clock Input Current LSB Mode MSB Mode	
				0	X	X	1		
				0	0	X	X		
				0	1	X	X		
0	0	1	0	D3	D2	D1	D0	2. POWER-DOWN ADC CHANNELS Power-Down Channels 1 to 4; D3 is for Channel 4 and D0 for Channel 1	Example: 1010 Powers Down Channels 4 and 2 and Keeps Channels 1 and 3 Alive
				X	X	X	X		
0	0	1	1	D3	D2	D1	D0	3. POWER-DOWN ADC CHANNELS Power-Down Channels 5 to 8; D3 is for Channel 8 and D0 for Channel 5	
				X	X	X	X		
				D3	D2	D1	D0	CUSTOM PATTERN (registers 4-6) Bits for Custom Pattern	
0	1	0	0	MSB	X	X	X		
0	1	0	1	X	X	X	X		
0	1	1	0	X	X	X	LSB		

PRODUCT PREVIEW

TEST PATTERNS(1)	
Deskew	101010101010
Sync	000000111111
Custom	Any 12-bit pattern that is defined in the custom pattern registers 4 to 6.

(1) Default is LSB first. If MSB is selected the above patterns will be reversed.

LVDS TIMING DIAGRAM (PER ADC CHANNEL)

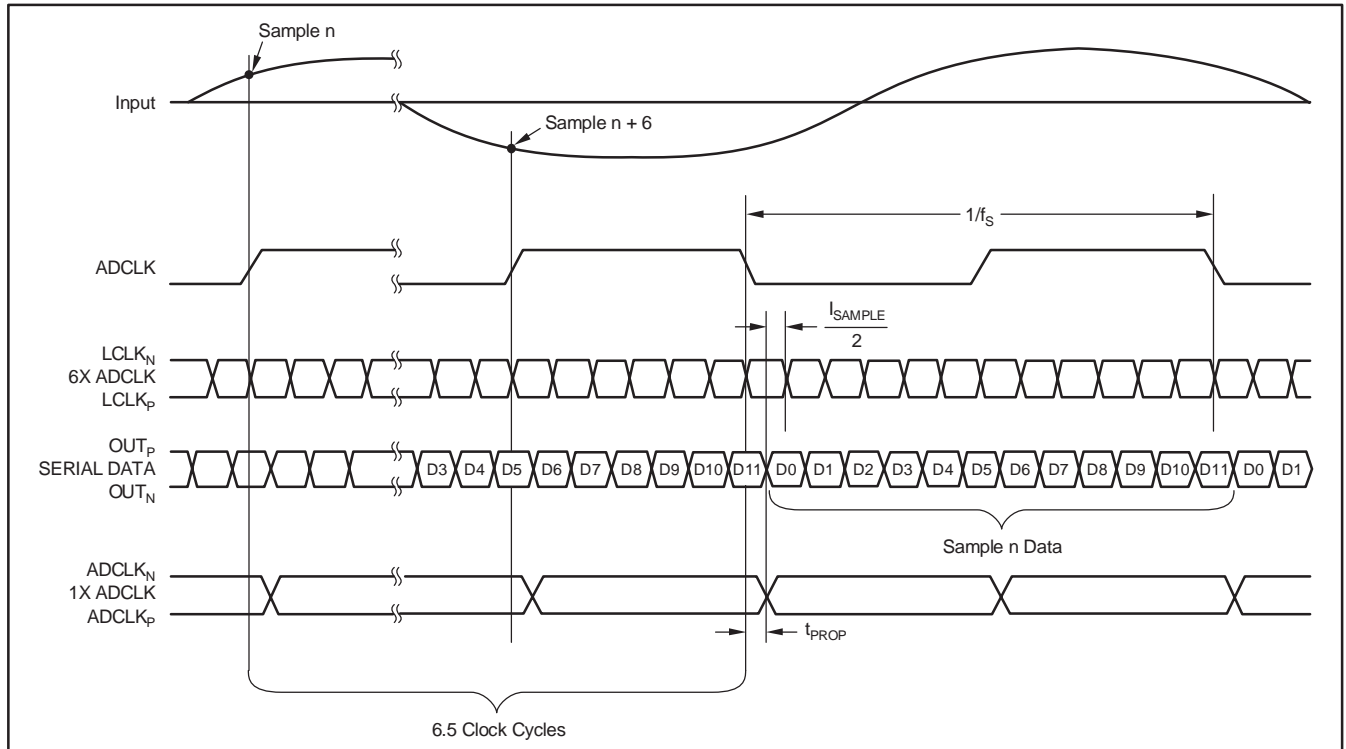

RESET TIMING

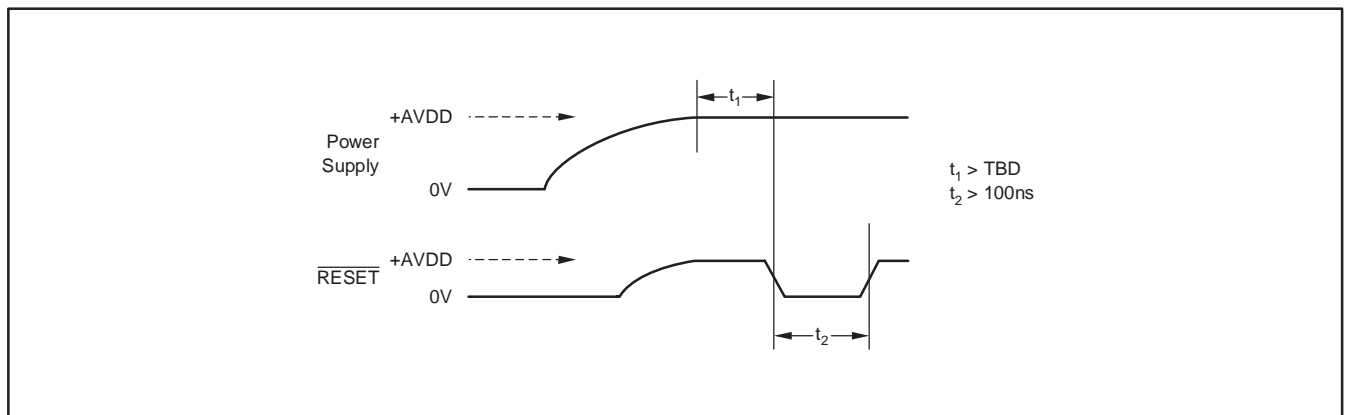

POWER-DOWN TIMING

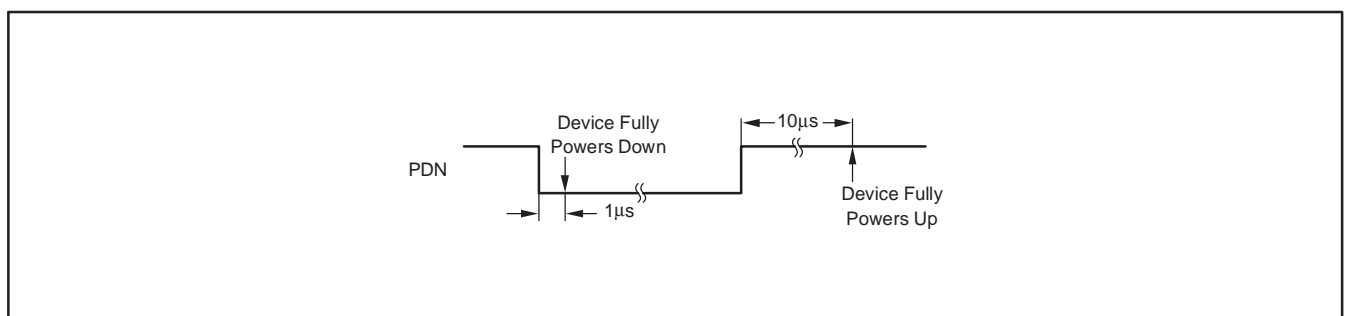

PIN CONFIGURATION

PRODUCT PREVIEW

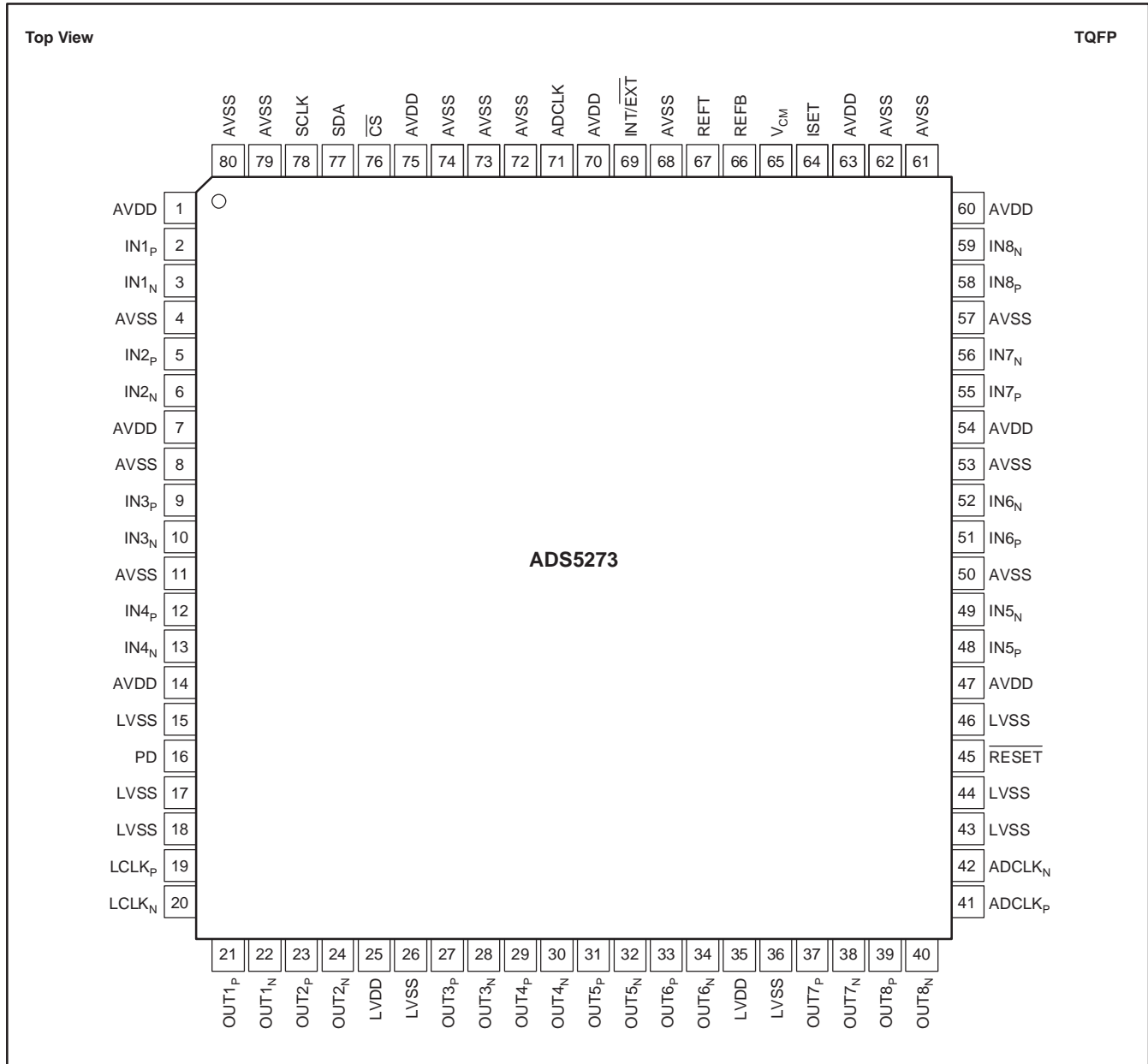

PIN DESCRIPTIONS

NAME	PIN #	NUMBER OF PINS	I/O	DESCRIPTION
AVDD	1, 7, 14, 47, 54, 60, 63, 70, 75	8	I	Analog Power Supply
AVSS	4, 8, 11, 50, 53, 57, 61, 62, 68, 72-74, 79, 80	14	I	Analog Ground
LVDD	25, 35	2	I	LVDS Power Supply
LVSS	15, 17, 18, 26, 36, 43, 44, 46	8	I	LVDS Ground
IN1P	2	1	I	Channel 1 Differential Analog Input High
IN1N	3	1	I	Channel 1 Differential Analog Input Low
IN2P	5	1	I	Channel 2 Differential Analog Input High
IN2N	6	1	I	Channel 2 Differential Analog Input Low
IN3P	9	1	I	Channel 3 Differential Analog Input High
IN3N	10	1	I	Channel 3 Differential Analog Input Low
IN4P	12	1	I	Channel 4 Differential Analog Input High
IN4N	13	1	I	Channel 4 Differential Analog Input Low
IN5P	48	1	I	Channel 5 Differential Analog Input High
IN5N	49	1	I	Channel 5 Differential Analog Input Low
IN6P	51	1	I	Channel 6 Differential Analog Input High
IN6N	52	1	I	Channel 6 Differential Analog Input Low
IN7P	55	1	I	Channel 7 Differential Analog Input High
IN7N	56	1	I	Channel 7 Differential Analog Input Low
IN8P	58	1	I	Channel 8 Differential Analog Input High
IN8N	59	1	I	Channel 8 Differential Analog Input Low
REFT	67	1	I/O	Reference Top Voltage
REFB	66	1	I/O	Reference Bottom Voltage
V _{CM}	65	1	O	Common-Mode Output Voltage
INT/EXT	69	1	I	Internal/External Reference Select; 0 = External, 1 = Internal
PD	16	1	I	Power-Down; 0 = Normal, 1 = Power-Down
LCLK _P	19	1	O	Positive LVDS Clock
LCLK _N	20	1	O	Negative LVDS Clock
ADCLK	71	1	I	Data Converter Clock Input
OUT1P	21	1	O	Channel 1 Positive LVDS Data Output
OUT1N	22	1	O	Channel 1 Negative LVDS Data Output
OUT2P	23	1	O	Channel 2 Positive LVDS Data Output
OUT2N	24	1	O	Channel 2 Negative LVDS Data Output
OUT3P	27	1	O	Channel 3 Positive LVDS Data Output
OUT3N	28	1	O	Channel 3 Negative LVDS Data Output
OUT4P	29	1	O	Channel 4 Positive LVDS Data Output
OUT4N	30	1	O	Channel 4 Negative LVDS Data Output
OUT5P	31	1	O	Channel 5 Positive LVDS Data Output
OUT5N	32	1	O	Channel 5 Negative LVDS Data Output
OUT6P	33	1	O	Channel 6 Positive LVDS Data Output
OUT6N	34	1	O	Channel 6 Negative LVDS Data Output
OUT7P	37	1	O	Channel 7 Positive LVDS Data Output
OUT7N	38	1	O	Channel 7 Negative LVDS Data Output
OUT8P	39	1	O	Channel 8 Positive LVDS Data Output
OUT8N	40	1	O	Channel 8 Negative LVDS Data Output
ADCLK _P	41	1	O	Positive LVDS ADC Clock Output
ADCLK _N	42	1	O	Negative LVDS ADC Clock Output
ISET	64	1	I/O	Bias Current Setting Resistor
RESET	45	1	I	Reset to Default; 0 = Reset, 1 = Normal
CS	76	1	I	Chip Select; 0 = Select, 1 = No Select
SDA	77	1	I	Serial Data Input
SCLK	78	1	I	Serial Data Clock

TYPICAL CHARACTERISTICS

$T_{MIN} = -40^{\circ}C$, and $T_{MAX} = +85^{\circ}C$. Typical values are at $T_A = 25^{\circ}C$, clock frequency = maximum specified, 50% clock duty cycle, AVDD = 3.3V, LVDD = 3.3V, -0.5dBFS, internal voltage reference, and LVDS buffer current at 3.5mA per channel, unless otherwise noted.

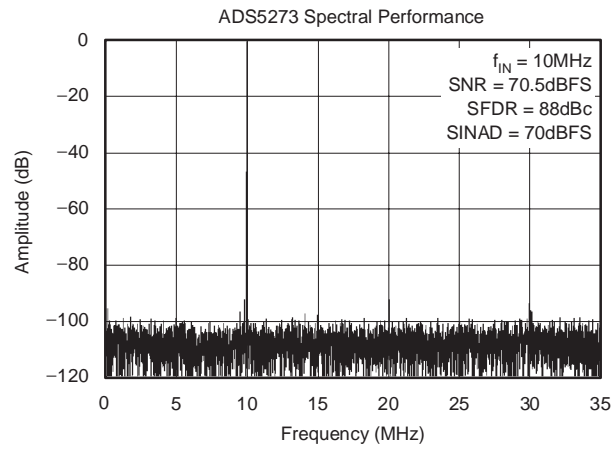

THEORY OF OPERATION

OVERVIEW

The ADS5273 is an 8-channel, high-speed, CMOS ADC, consisting of a high-performance sample-and-hold circuit at the input, followed by a 12-bit ADC. The 12 bits given out by each channel are serialized and sent out on a single pair of pins in LVDS format. All eight channels of the ADS5273 operate from a single clock referred to as ADCLK. The sampling clock for each of the eight channels is generated from the input clock using a carefully matched clock buffer tree. The 12X clock required for the serializer is generated internally from ADCLK using a phase lock loop (PLL). A 6X and a 1X clock are also output in LVDS format along with the data to enable easy data capture. The ADS5273 operates from an internally generated reference voltage that is trimmed to ensure matching across multiple devices on a board. This feature eliminates the need for external routing of reference lines and also improves matching of the gain across devices. The nominal values of REF_P and REF_N are 2V and 1V, respectively. These values imply that a differential input of $-1V$ corresponds to the zero code of the ADC, and a differential input of $+1V$ corresponds to the full-scale code (4095 LSB). V_{CM} (common-mode voltage of REF_P and REF_N) is also made available externally through a pin, and is nominally 1.5V.

The ADC employs a pipelined converter architecture consisting of a combination of multi-bit and single-bit internal stages. Each stage feeds its data into the digital error correction logic, ensuring excellent differential linearity and no missing codes at the 12-bit level. The pipeline architecture results in a data latency of 6.5 clock cycles.

The output of the ADC goes to a serializer that operates from a 12X clock generated by the PLL. The 12 data bits from each channel are serialized and sent LSB first. In addition to serializing the data, the serializer also generates a 1X clock and a 6X clock. These clocks are generated in the same way the serialized data is generated, so these clocks maintain perfect synchronization with the data. The data and clock outputs of the serializer are buffered externally using LVDS buffers. Using LVDS buffers to transmit data externally has multiple advantages, such as a reduced number of output pins (saving routing space on the board), reduced power consumption, and reduced effects of digital noise coupling to the analog circuit inside the ADS5273.

The ADS5273 operates from two sets of supplies and grounds. The analog supply/ground set is denoted as AVDD/AVSS, while the digital set is denoted by LVDD/LVSS.

DRIVING THE ANALOG INPUTS

The analog input biasing is shown in Figure 1. The recommended method to drive the inputs is through AC coupling. AC coupling removes the worry of setting the common-mode of the driving circuit, since the inputs are biased internally using two 600Ω resistors. The sampling capacitor used to sample the inputs is 4pF. The choice of the external AC coupling capacitor is dictated by the attenuation at the lowest desired input frequency of operation factor. The attenuation resulting from using a 10nF AC coupling capacitor is 0.04%.

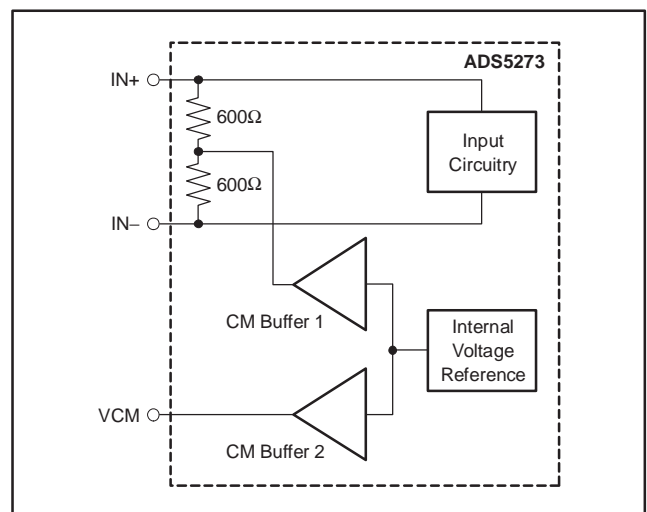

Figure 1. Analog Input Bias Circuitry

If the input is DC coupled, then the output common-mode voltage of the circuit driving the ADS5273 should match the V_{CM} (which is provided as an output pin) to within $\pm 50mV$. It is recommended that the output common-mode of the driving circuit be derived from V_{CM} provided by the device.

INPUT OVER-VOLTAGE RECOVERY

The differential full-scale input peak-to-peak supported by the ADS5273 is 2V. For a nominal value of V_{CM} (1.5V), IN_P and IN_N can swing from 1V to 2V. The ADS5273 is specially designed to handle an over-voltage differential peak-to-peak voltage of 4V (2.5V and 0.5V swings on IN_P and IN_N). If the input common-mode is not considerably off from V_{CM} during overload (less than 300mV), recovery from an over-voltage input condition is expected to be within 4 clock cycles. All of the amplifiers in the SHA and ADC are especially designed for excellent recovery from an overload signal.

REFERENCE CIRCUIT DESIGN

The digital beam-forming algorithm relies heavily on gain matching across all receiver channels. A typical system would have about 12 octal ADCs on the board. In such a case, it is critical to ensure that the gain is matched, essentially requiring the reference voltages seen by all the ADCs to be the same. Matching references within the eight channels of a chip is done by using a single internal reference voltage buffer. Trimming the reference voltages on each chip during production ensures the reference voltages are well matched across different chips.

All bias currents required for the internal operation of the device are set using an external resistor to ground at pin ISET. Using a 56k Ω resistor on ISET generates an internal reference current of 20 μ A. This current is mirrored internally to generate the bias current for the internal blocks. Using a larger external resistor at ISET reduces the reference bias current and thereby scales down the device operating power. However, it is recommended that the external resistor be within 10% of the specified value of 56k so that the internal bias margins for the various blocks are proper.

Buffering the internal bandgap voltage also generates a voltage called V_{CM} , which is set to the midlevel of REF_T and REF_B , and is accessible on a pin. The internal buffer driving V_{CM} has a drive of ± 4 mA. It is meant as a reference voltage to derive the input common-mode in case the input is directly coupled.

The device also supports the use of external reference voltages. This involves forcing REF_T and REF_B externally. In this mode, the internal reference buffer is tri-stated. Since the switching current for the eight ADCs come from the externally forced references, it is possible for the performance to be slightly less than when the internal references are used. It should be noted that in this mode, V_{CM} and ISET continue to be generated from the internal bandgap voltage, as in the internal reference mode. It is therefore important to ensure that the common-mode voltage of the externally forced reference voltages matches to within 50mV of V_{CM} .

CLOCKING

The eight channels on the chip run off a single ADCLK input. To ensure that the aperture delay and jitter are same for all the channels, a clock tree network is used to generate individual sampling clocks to each channel. The clock paths for all the channels are matched from the source point all the way to the sample-and-hold. This ensures that the performance and timing for all the channels are identical. The use of the clock tree for matching introduces an aperture delay, which is defined as the delay between the rising edge of ADCLK and the actual instant of sampling. The aperture delays for all the channels are matched, and vary between 2.5ns to 4.5ns.

Another critical specification is the aperture jitter that is defined as the uncertainty of the sampling instant. The gates in the clock path are designed so as to give an rms jitter of about 1ps.

The input ADCLK should ideally have a 50% duty cycle. However, while routing ADCLK to different components on board, the duty cycle of the ADCLK reaching the ADS5273 could deviate from 50%. A smaller (or larger) duty cycle eats into the time available for sample or hold phases of each circuit, and is therefore not optimal. For this reason, the internal PLL is used to generate an internal clock that has 50% duty cycle.

The use of the PLL automatically dictates the lower frequency of operation to be about 20MHz.

LVDS BUFFERS

The LVDS buffer has two current sources, as shown in Figure 2. OUT_P and OUT_N are loaded externally by a resistive load that is ideally about 100 Ω . Depending on the data being 0 or 1, the currents are directed in one or the other direction through the resistor. The LVDS buffer has four current settings. The default current setting is 3.5mA, and gives a differential drop of about ± 350 mV across the 100 Ω resistor.

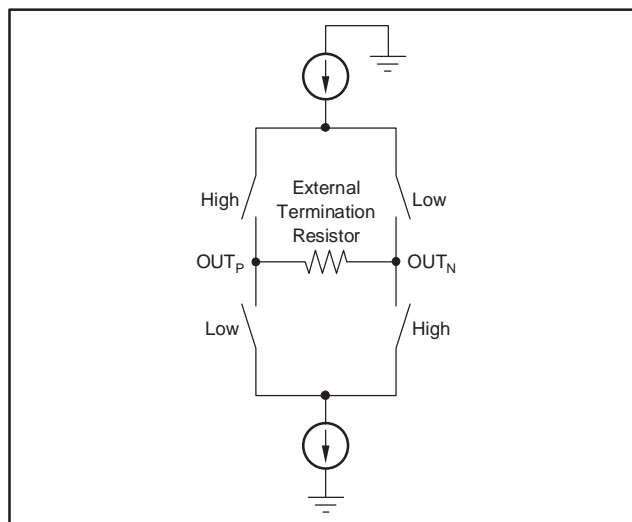

Figure 2. LVDS Buffer

The LVDS buffer gets data from a serializer that takes the output data from each channel and serializes it into a single data stream. For a clock frequency of 40MHz, the data rate output by the serializer is 480 MBPS. The data comes out LSB first, with a register programmability to revert to MSB first. The serializer also gives out a 1X clock and a 6X clock. The 6X clock (denoted as LCLK_P/LCLK_N) is meant to synchronize the capture of the LVDS data. The deskew mode can be enabled as well, using a register setting. This mode gives out a data stream of alternate 0s and 1s and can be used determine the relative delay

between the 6X clock and the output data for optimum capture. A 1X clock is also generated by the serializer and transmitted by the LVDS buffer. The 1X clock (referred to as ADCLK_P/ADCLK_N) is used to determine the start of the 12-bit data frame. The sync mode (enabled through a register setting) gives out a data of six 0s followed by six 1s. Using this mode, the 1X clock can be used to determine the start of the data frame. In addition to the deskew mode pattern and the sync pattern, a custom pattern can be defined by the user and output from the LVDS buffer.

NOISE COUPLING ISSUES

High-speed mixed signals are sensitive to various types of noise coupling. One of the main sources of noise is the switching noise from the serializer and the output buffers. Maximum care is taken to isolate these noise sources from the sensitive analog blocks. As a starting point, the analog and digital domains of the chip are clearly demarcated. AVDD and AVSS are used to denote the supplies for the analog sections, while LVDD and LVSS are used to denote the digital supplies. Care is taken to ensure that there is minimal interaction between the supply sets within the device. The extent of noise coupled and transmitted from the digital to the analog sections depends on the following:

1. The effective inductances of each of the supply/ground sets.
2. The isolation between the digital and analog supply/ground sets.

Smaller effective inductance of the supply/ground pins leads to better suppression of the noise. For this reason, multiple pins are used to drive each supply/ground. It is also critical to ensure that the impedances of the supply and ground lines on board are kept to the minimum possible values. Use of ground planes in the board as well as large decoupling capacitors between the supply and ground lines are necessary to get the best possible SNR from the device.

It is recommended that the isolation be maintained on board by using separate supplies to drive AVDD and LVDD, as well as separate ground planes for AVSS and LVSS.

The use of LVDS buffers reduces the injected noise considerably, compared to CMOS buffers. The current in the LVDS buffer is independent of the direction of switching. Also, the low output swing as well as the differential nature of the LVDS buffer results in low-noise coupling.

POWER-DOWN MODE

The ADS52763 has a power-down pin, PD. Pulling PD high causes the devices to enter the power-down mode. In this mode, the reference and clock circuitry as well as all the channels are powered down. Device power consumption drops to less than 100mW in this mode. Individual channels can also be selectively powered down by programming registers.

The ADS5273 also has an internal circuit that monitors the state of stopped clocks. If ADCLK is stopped (or if it runs at a speed < 3MHz), this monitoring circuit generates a logic signal that puts the device in a power-down state. As a result, the power consumption of the device goes to less than 100mW when ADCLK is stopped. This circuit can also be disabled using register options.

SUPPLY SEQUENCE

The following supply sequence is recommended for powering up the device:

1. AVDD is powered up.
2. LVDD is powered up.

After the supplies have stabilized, the device must receive an active RESET pulse. This results in all internal registers getting reset to their default value of 0 (inactive). Without RESET, it is possible that some registers might be in their non-default state on power-up. This could cause the device to malfunction.

IMPORTANT NOTICE

Texas Instruments Incorporated and its subsidiaries (TI) reserve the right to make corrections, modifications, enhancements, improvements, and other changes to its products and services at any time and to discontinue any product or service without notice. Customers should obtain the latest relevant information before placing orders and should verify that such information is current and complete. All products are sold subject to TI's terms and conditions of sale supplied at the time of order acknowledgment.

TI warrants performance of its hardware products to the specifications applicable at the time of sale in accordance with TI's standard warranty. Testing and other quality control techniques are used to the extent TI deems necessary to support this warranty. Except where mandated by government requirements, testing of all parameters of each product is not necessarily performed.

TI assumes no liability for applications assistance or customer product design. Customers are responsible for their products and applications using TI components. To minimize the risks associated with customer products and applications, customers should provide adequate design and operating safeguards.

TI does not warrant or represent that any license, either express or implied, is granted under any TI patent right, copyright, mask work right, or other TI intellectual property right relating to any combination, machine, or process in which TI products or services are used. Information published by TI regarding third-party products or services does not constitute a license from TI to use such products or services or a warranty or endorsement thereof. Use of such information may require a license from a third party under the patents or other intellectual property of the third party, or a license from TI under the patents or other intellectual property of TI.

Reproduction of information in TI data books or data sheets is permissible only if reproduction is without alteration and is accompanied by all associated warranties, conditions, limitations, and notices. Reproduction of this information with alteration is an unfair and deceptive business practice. TI is not responsible or liable for such altered documentation.

Resale of TI products or services with statements different from or beyond the parameters stated by TI for that product or service voids all express and any implied warranties for the associated TI product or service and is an unfair and deceptive business practice. TI is not responsible or liable for any such statements.

Following are URLs where you can obtain information on other Texas Instruments products and application solutions:

Products		Applications	
Amplifiers	amplifier.ti.com	Audio	www.ti.com/audio
Data Converters	dataconverter.ti.com	Automotive	www.ti.com/automotive
DSP	dsp.ti.com	Broadband	www.ti.com/broadband
Interface	interface.ti.com	Digital Control	www.ti.com/digitalcontrol
Logic	logic.ti.com	Military	www.ti.com/military
Power Mgmt	power.ti.com	Optical Networking	www.ti.com/opticalnetwork
Microcontrollers	microcontroller.ti.com	Security	www.ti.com/security
		Telephony	www.ti.com/telephony
		Video & Imaging	www.ti.com/video
		Wireless	www.ti.com/wireless

Mailing Address: Texas Instruments
Post Office Box 655303 Dallas, Texas 75265