



CLARE

**LITELINK™ (CPC5600 AND CPC5604)
Optical Data Access Arrangement**

**Application Note
Upgrading from CPC5600
to CPC5604**

Contents

1.0	Introduction	3
2.0	Product Comparison	3
3.0	Package Drawings	
3.1	CPC5600 Package Drawing	4
3.1.1	CPC5600 Pin Definitions and Functions	4
3.2	CPC5604 Package Drawing	5
3.2.1	CPC5604 Pin Definitions and Functions	5
4.0	LITELINK Family Compatible Reference Designs	
4.1	North American Family Compatible Schematic	6
4.1.1	North American Family Compatible BOM	7
4.2	International Family Compatible Schematic	8
4.2.1	International Family Compatible BOM	9
4.3	Family Compatible Lucent Reference Design	10
4.4	Family Compatible Conexant Reference Design	11
5.0	CPC5604 Optimized Reference Designs	
5.1	CPC5604 North American Schematic	12
5.1.1	CPC5604 North American BOM	13
5.2	CPC5604 International Schematic	14
5.2.1	CPC5604 International BOM	15
5.3	CPC5604 CTR21 Schematic	16
5.3.1	CPC5604 CTR21 BOM	17
5.4	CPC5604 CTR21 with exceptions Schematic	18
5.4.1	CPC5604 CTR21 with exceptions BOM	19
5.5	CPC5604 Lucent Reference design	20
5.6	CPC5604 Conexant Reference design	21

LiteLink™ Family of Optical Data Access Arrangement

1.0 Introduction

CP Clare's LITELINK™ family of single package DAA solutions can be used for a variety of telephone line interface applications including high performance 56kbps modems. The LITELINK™ family of products are advanced integrated circuits that use optical signal coupling techniques to provide the required electrical isolation between the telephone line and the user's host circuitry. The LITELINK™ family differs from other DAA solutions utilizing either optical or capacitive isolation techniques by including the barrier inside the IC package which eliminates the need for external high voltage capacitors or optocouplers in the data path, thus saving board space and lowering cost. The LITELINK™ family of products has been designed to meet or exceed the requirements of international regulatory agencies.

The CPC5600 was the first in the series of LITELINK™ products. The CPC5600 low profile package and optical isolation barrier offers designers the opportunity to implement a full DAA circuit using less board space than previously possible.

The CPC5604 is the next generation of LITELINK™ product. The CPC5604 offers the same optical isolation barrier and all the benefits of the CPC5600 along with a lower noise floor that allows higher data through put rates. The CPC5604 also takes the CP Clare's international solution one step further by simplifying the implementation of CTR21.

The key features of the LITELINK™ family of DAAs are as follows:

- Full differential or single ended transmit and receive signal coupling from the telephone line to the host system
- High voltage (1500 VRMS) isolation between telephone line and host
- Ring signal detection
- Caller ID signal detection
- Hookswitch function
- Internal 2-4 wire converter
- Low power consumption
- Flat frequency response 30-4000Hz
- Low THD -80db
- Minimum number of external components required
- Programmable International solution with CPC5601 chip
- PC Card and PCMCIA compatible packaging
- Current Limiting

For international PTT compliance, external passive components can be changed to meet different country requirements. Using the LITELINK™ in conjunction with the CPC5601 programmable driver, will offer a software programmable solution using a digital serial interface to the host's microcontroller. See CPC5601 Data Sheet for details on software programmable solutions.

2.0 Product Comparison

The CPC5600 differs from the CPC5604 in the following manner:

Characteristic	CPC5600	CPC5604
Average in band Noise	-90 db	-100db
Function of pin 22	Main loop current path from Tip to Ring (IDC)	DC Filter (DCF)

The CPC5604 also contains enhancements to the chip to provide a greater margin in meeting section 4.6.2 Loop current Characteristics of CTR21.

APPLICATION NOTE

UPGRADING FROM CPC5600 TO CPC5604



3.0 Package Drawings

3.1 CPC5600 Package Drawing

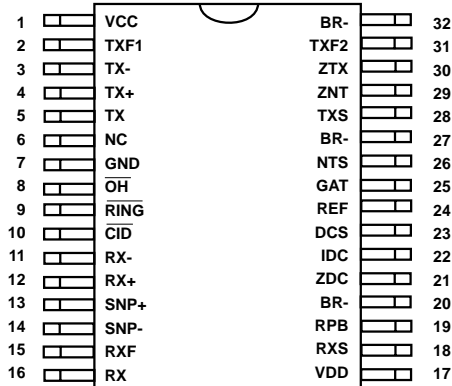

3.1.1 CPC5600 Pin Definitions and Functions

Pin #	Name	Function
1	V _{CC}	Host power supply, +5 Volts +/-5%.
2	TXF1	TX isolation amplifier output.
3	TX -	NEG differential transmit signal into DAA.
4	TX+	POS differential transmit signal into DAA.
5	TX	TX differential amplifier input.
6	NC	Not Connected.
7	GND	Connect to host analog ground.
8	OH	Driving this signal low asserts the off-hook condition.
9	RING	Active low indicates an incoming half waved ring signal pulsed High to Low at the ring frequency-typically 20Hz.
10	CID	Driving this signal low places the Caller ID information on the RX pins when the DAA is on hook (OH is de-asserted).
11	RX-	NEG differential analog receive signal from the telephone line and must be AC coupled with a 0.1 uF capacitor.
12	RX+	POS differential analog receive signal from the telephone line and must be AC coupled with a 0.1 uF capacitor.
13	SNP+	One of two differential snoop inputs.
14	SNP-	One of two differential snoop inputs.
15	RXF	Receive photodiode amplifier output.
16	RX	Receive photoamplifier summing junction.
17	V _{DD}	Power supply for line side portion of CPC5600A.
18	RXS	Receive photodiode servo input.
19	RPB	Sets receive LED prebias current.
20	BR-	Return to bridge rectifier negative output.
21	ZDC	Sets electronic inductor DCR/Current Limit.
22	IDC	Main loop current path from Tip to Ring.
23	DCS	VI slope control via external resistor.
24	REF	1.25V internal voltage reference.
25	GAT	Depletion MOSFET gate control.
26	NTS	Receive signal input path via Tip and Ring.
27	BR-	Return to bridge rectifier negative output.
28	TXS	Receive photodiode amplifier input.
29	ZNT	Sets DAA impedance via external passive network.
30	ZTX	Transmit Transconductance gain setting pin.
31	TXF2	Receive photodiode amplifier output.
32	BR-	Return to bridge rectifier negative output.

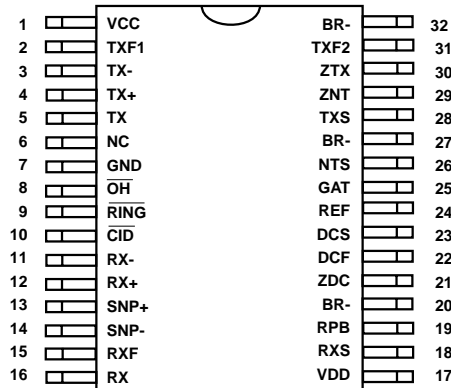
3.2 CPC5604 Package Drawing

3.2.1. CPC5604 Pin Definitions and Functions

Pin #	Name	Function
1	V _{CC}	Host power supply, +5 Volts +/-5%.
2	TXF1	TX isolation amplifier output.
3	TX -	NEG differential transmit signal into DAA.
4	TX+	POS differential transmit signal into DAA.
5	TX	TX differential amplifier input.
6	NC	Not Connected.
7	GND	Connect to host analog ground.
8	OH	Driving this signal low asserts the off-hook condition.
9	RING	Active low indicates an incoming half waved ring signal pulsed High to Low at the ring frequency-typically 20Hz.
10	CID	Driving this signal low places the Caller ID information on the RX pins when the DAA is on hook (OH is de-asserted).
11	RX-	NEG differential analog receive signal from the telephone line and must be AC coupled with a 0.1 uF capacitor.
12	RX+	POS differential analog receive signal from the telephone line and must be AC coupled with a 0.1 uF capacitor.
13	SNP+	One of two differential snoop inputs.
14	SNP-	One of two differential snoop inputs.
15	RXF	Receive photodiode amplifier output.
16	RX	Receive photoamplifier summing junction.
17	V _{DD}	Power supply for line side portion of CPC5604.
18	RXS	Receive photodiode servo input.
19	RPB	Sets receive LED prebias current.
20	BR-	Return to bridge rectifier negative output.
21	ZDC	Sets electronic inductor DCR/Current Limit.
22	DCF	DC Filter Point.
23	DCS	VI slope control via external resistor.
24	REF	1.25V internal voltage reference.
25	GAT	Depletion MOSFET gate control.
26	NTS	Receive signal input path via Tip and Ring.
27	BR-	Return to bridge rectifier negative output.
28	TXS	Receive photodiode amplifier input.
29	ZNT	Sets DAA impedance via external passive network.
30	ZTX	Transmit Transconductance gain setting pin.
31	TXF2	Receive photodiode amplifier output.
32	BR-	Return to bridge rectifier negative output.



APPLICATION NOTE

UPGRADING FROM CPC5600 TO CPC5604

4.0 Family Compatible Schematics

The upgrade path from the CPC5600 to the CPC5604 is easy using the Family Compatible schematics. The schematics are also included in the CPC5600 datasheet and Application note and were designed to allow the design

engineer board population options to accommodate both LITELINK products. Each Schematic contains a table showing the optional components and the values necessary to implement the CPC5600 or the CPC5604.

4.1 North American Family Compatible Schematic

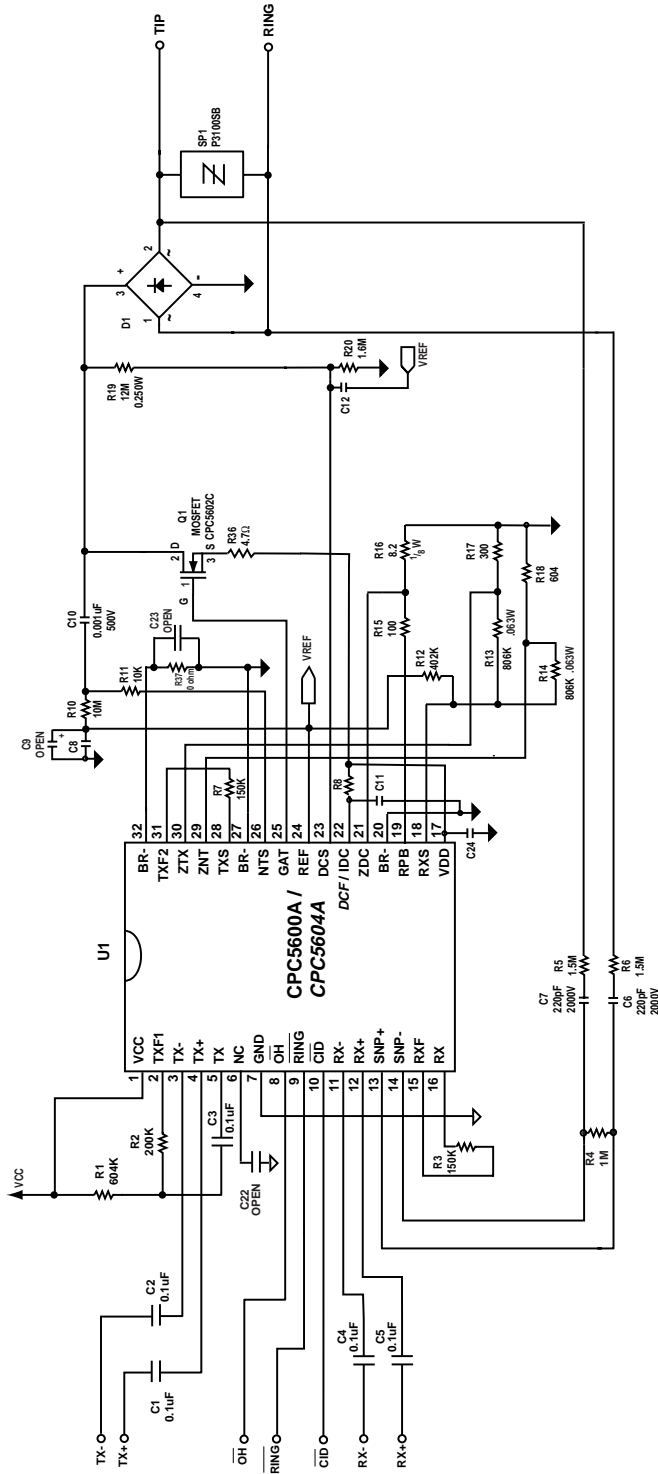

Table 1

Component	CPC5600A	CPC5604
R8	0 Ohm	Open
C8	0.47uF	0.1uF
C11	0.01uF	0.47uF Tant
C12	0.027uF	Open
C24	Open	0.01uF

Drawn:	DAI/IMG	Rev:	1
Date:	10/2/99		
Company:	CP Clare Corp.		
Title:	U.S. Reference Design		

ALL RESISTORS ARE 100W
UNLESS OTHERWISE NOTED

4.1.1 North American Family Compatible BOM

QTY.	Designation	Description	Manufacturer	Package Type
1	U1	CPC5600A	CP Clare	32 Lead SOIC
1	Q1	CPC5602C	CP Clare	SOT-223
1	R1	604k 1% Res.	Meritek	'0603
1	R18	604 ohm 1% Res.	Meritek	'0603
1	R2	200k 5% Res.	Meritek	'0603
1	R4	1M ohms 5% Res.	Meritek	'0603
1	R8	See Schematic Table 1	Meritek	'0603
2	R3, R7	150k 5% Res.	Meritek	'0603
2	R5, R6	1.5M 5% Res.	Meritek	'0603
1	R11	10 K 5% Res.	Meritek	'0603
1	R12	402k 1% Res.	Meritek	'0603
1	R15	100 ohm 5% Res.	Meritek	'0603
2	R13, R14	806K 1% Res. 0.063W	Meritek	'0603
1	R16	8.2 5% Res. 1/8W	Meritek	'0603
1	R17	300 ohm 5% Res.	Meritek	'0603
1	R10	10M 5% Res.	Meritek	'0603
1	R19	12M 5% Res. 0.25W	Meritek	'0805
1	R20	1.6M 5% Res.	Meritek	'0805
1	R36	4.7 ohm 5% Res 1/8 W	Meritek	'0603
1	R37	0 ohm Res.	Meritek	'0603
5	C1, C2, C3, C4, C5	0.1 uf 50V 10% X7R	Tecate	'0805
2	C6, C7	220 pf 2000V NPO 5%	Tecate	1808
1	C8	See Schematic Table 1	Tecate	'0805
1	C11	See Schematic Table 1	Tecate/Panasonic	SMD
1	C9	Open	-	-
1	C10	0.001uf 500V10% X7R	Tecate	1206
1	C12	See Schematic Table 1	Tecate	'0805
1	C23	Open	-	-
1	C24	See Schematic Table 1	Tecate	'0805
1	D1	Bridge Rectifier	Shindengen	N/A
1	SP1	Surge Protection	Teccor	D0-214AA
37	TOTAL			

APPLICATION NOTE

UPGRADING FROM CPC5600 TO CPC5604

4.2 International Family Compatible Schematic

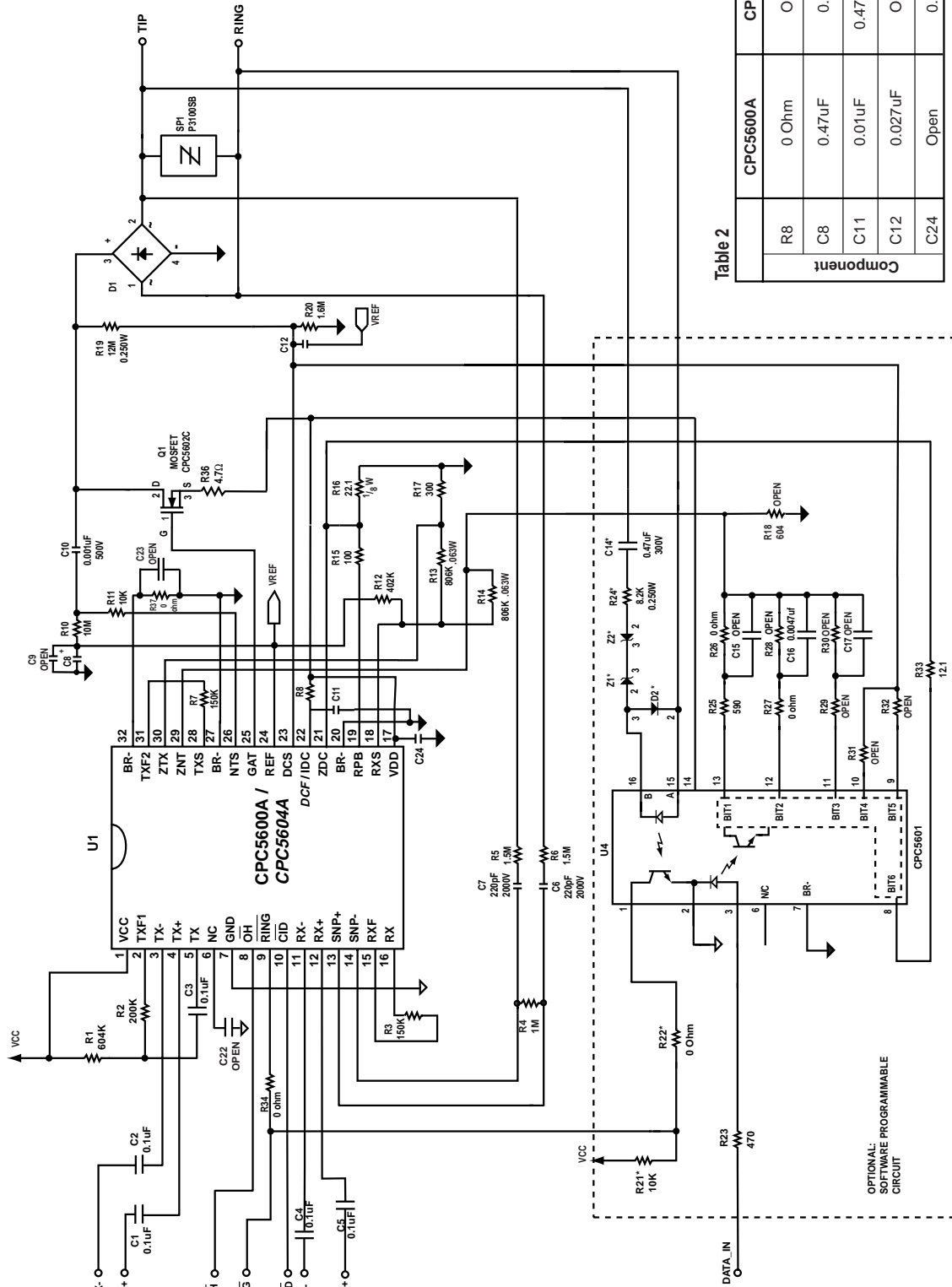

Table 2

Component	CPC5600A	CPC5604
R8	0 Ohm	Open
C8	0.47uF	0.1uF
C11	0.01uF	0.47uF Tant
C12	0.027uF	Open
C24	Open	0.01uF

Drawn: JC/MG	Date: 10/27/99	Rev: J
Company: CP Clare Corp.		
Title: International Reference Design		

ALL RESISTORS ARE 100W UNLESS OTHERWISE NOTED

* For external ring detect only.

OPTIONAL: SOFTWARE PROGRAMMABLE CIRCUIT

4.2.1 International Family Compatible BOM

QTY.	Designation	Description	Manufacturer	Package Type
1	U1	CPC5600A	CP Clare	32 Lead SOIC
1	U4	CPC5601D	CP Clare	S016
1	Q1	CPC5602C	CP Clare	SOT-223
1	R1	604k ohm 1% Res.	Meritek	'0603
1	R18	604 ohm 1% Res.	Meritek	'0603
1	R2	200k ohm 5% Res.	Meritek	'0603
1	R4	1M ohm 5% Res.	Meritek	0603
1	R8	See Schematic Table 2	Meritek	0603
2	R3, R7	150k ohm5% Res.	Meritek	'0603
2	R5, R6	1.5M ohm5% Res.	Meritek	'0603
1	R11	10 K ohm 5% Res.	Meritek	'0603
1	R12	402k ohm 1% Res.	Meritek	'0603
1	R15	100 ohm 5% Res.	Meritek	'0603
2	R13, R14	806K 1% ohm Res. 0.063W	Meritek	'0603
1	R16	22.1 ohm 5% Res. 1/8W	Meritek	'0603
1	R17	300 ohm 5% Res.	Meritek	'0603
1	R10	10M ohm5% Res.	Meritek	'0603
1	R19	12M ohm5% Res. 0.25W	Meritek	'0805
1	R20	1.6M ohm 5% Res.	Meritek	'0805
1	R23	470 ohm 5% Res.	Meritek	'0603
1	R24	8.2k ohm 5% Res. 0.25W	Meritek	'0603
4	R29, R30, R31, R32	Open	-	'0603
1	R25	590 ohm 5% Res.	Meritek	'0603
1	R26	0 ohm Res.	Meritek	'0603
1	R27	0 ohm Res.	Meritek	'0603
1	R28	Open	-	'0603
1	R33	12.1 ohm 5% Res.	Meritek	'0603
1	R34	0 ohm Res.	Meritek	'0603
1	R36	4.7 ohm 5% Res 1/8 W	Meritek	'0603
1	R37	0 ohm Res.	Meritek	'0603
5	C1, C2, C3, C4, C5	0.1 uf 50V 10% X7R	Tecate	'0805
2	C6, C7	220 pf 2000V NPO 5%	Tecate	1808
1	C8	See Schematic Table 2	Tecate	'0805
1	C11	See Schematic Table 2	Tecate/Panasonic	SMD
1	C9	Open	-	-
1	C10	0.001uf 500V10% X7R	Tecate	1206
1	C12	See Schematic Table 2	Tecate	'0805
1	C14	.47uf 300V	Tecate	1812
1	C15	Open	-	'0805
1	C16	0.0047 uf 50V 10% X7R	Tecate	'0805
1	C17	Open for future use	-	'0805
1	C23	Open	-	-
1	C24	See Schematic Table 2	Tecate	'0805
1	SP1	Surge Protection	Teccor	D0-214AA
2	Z1, Z2	Zener 20V	Rohm	SOT-23
1	D1	Bridge Rectifier	Shindengen	N/A
1	D2	Diode BAS16	Rohm	SOT-23
56	TOTAL			

APPLICATION NOTE

UPGRADING FROM CPC5600 TO CPC5604

4.3 Family Compatible Lucent Reference Design

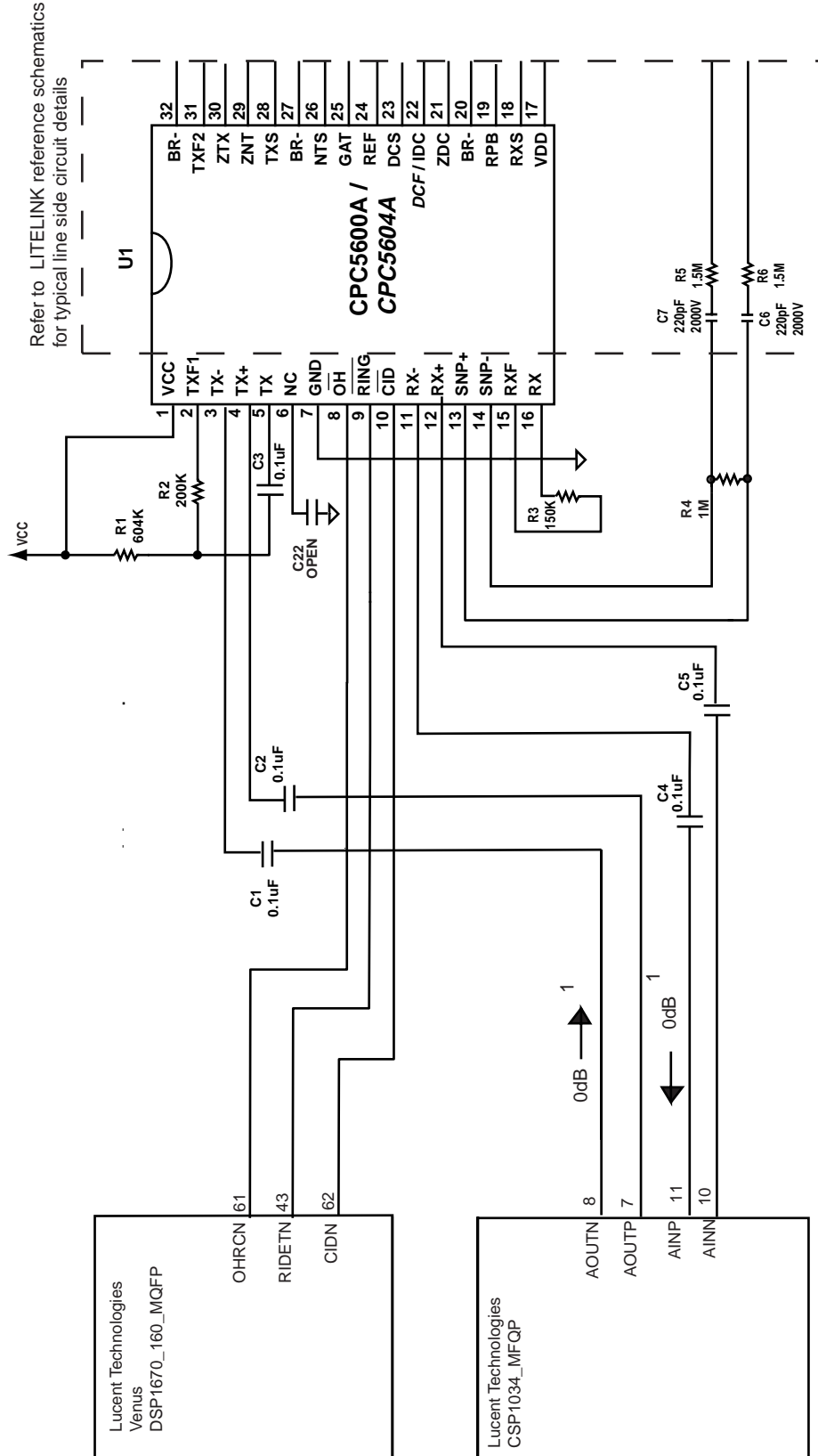

Drawn: ADH	Date: 6/25/99	Rev: C
Company: GP Clare Corp.		
Title: Interconnection To Lucent		

ALL RESISTORS ARE .100W
UNLESS OTHERWISE NOTED

1. Lucent chips expect a zero dB drop between the codec and Tip and Ring.

4.4 Family Compatible Conexant Reference Design

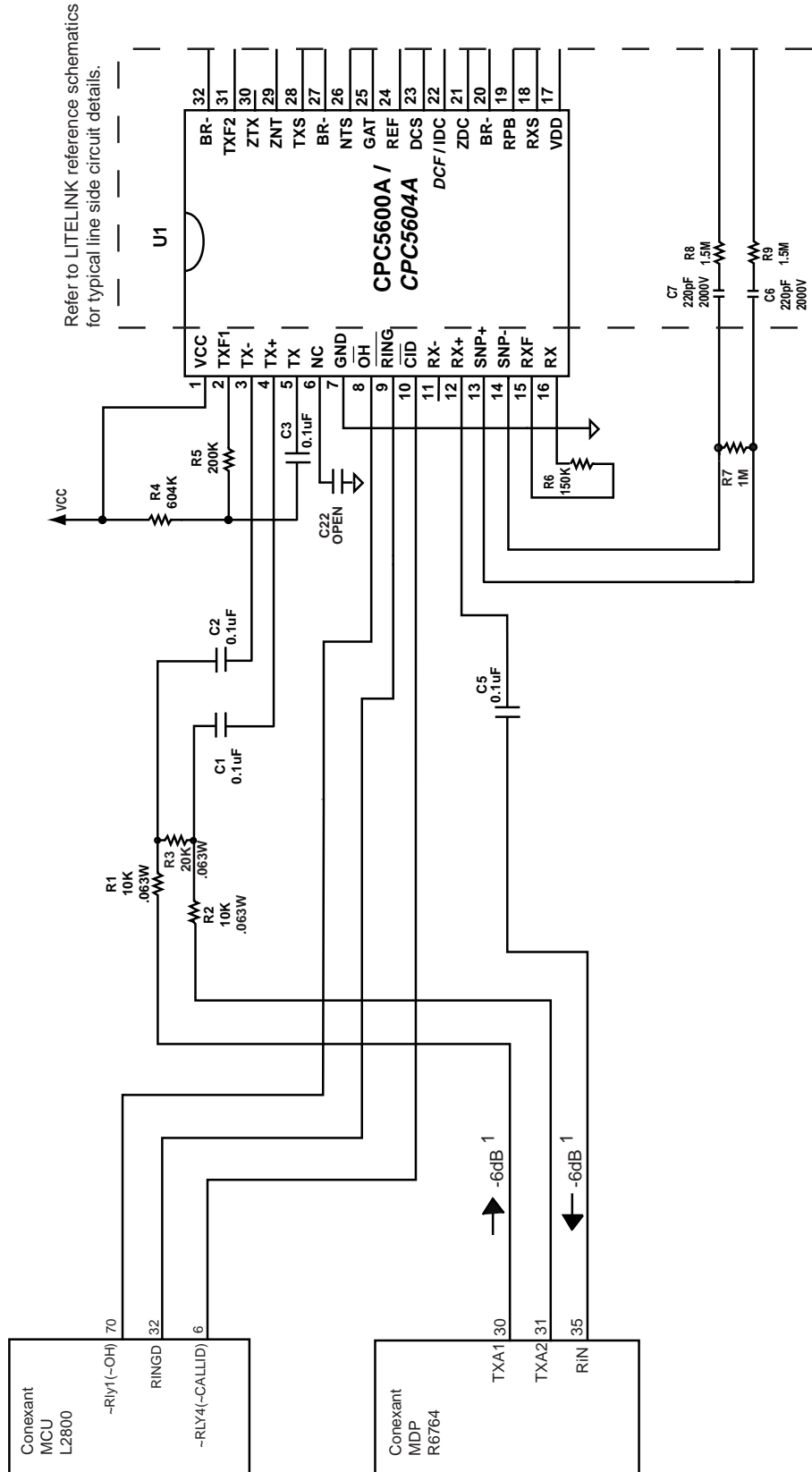

Refer to LITELINK reference schematics for typical line side circuit details.

Drawn: ADH	Date: 6/25/99	Rev: C
Company: CP Clare Corp.		
Title: Interconnection to Conexant(Rockwell)		

ALL RESISTORS ARE 100W UNLESS OTHERWISE NOTED

Interconnection diagram is based on the Conexant(Rockwell) RC56D Chip solution.
 1. Conexant Chipsets rely on a 6dB loss between MDP and tip and ring. This is solved by placing the R1, R2, R3, resistor circuit in the Transmit Path and the use of a single end of the differential receive.

APPLICATION NOTE

UPGRADING FROM CPC5600 TO CPC5604

5.0 CPC5604 Optimized Schematics

The following schematics are optimized versions of the Family Compatible schematics that allow a lower component count implementation of the CPC5604 LITELINK design. They do not allow backward compat-

ibility to the CPC5600. The schematics below should be used in designs where the performance of the CPC5604 is required.

5.1 CPC5604 North American Schematic

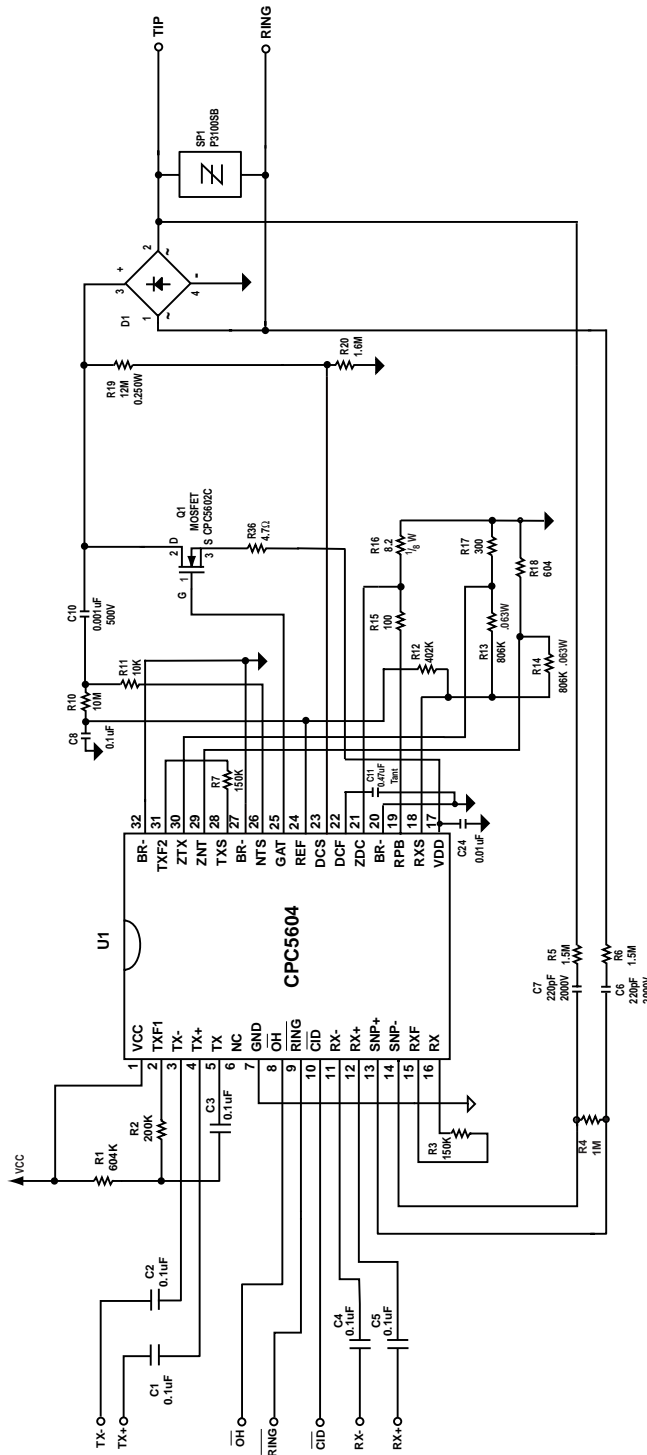

Drawn:	JCM/G	Date:	10/27/99	Rev.:	B
Company:	CP Clare Corp.				
Title:	U.S. Reference Design				

ALL RESISTORS ARE .100W UNLESS OTHERWISE NOTED

5.1.1 CPC5604 North American BOM

QTY.	Designation	Description	Manufacturer	Package Type
1	U1	CPC5604A	CP Clare	32 Lead SOIC
1	Q1	CPC5602C	CP Clare	SOT-223
1	R1	604k 1% Res.	Meritek	'0603
1	R18	604 ohm 1% Res.	Meritek	'0603
1	R2	200k 5% Res.	Meritek	'0603
1	R4	1M 5% Res	Meritek	0603
2	R3, R7	150k 5% Res.	Meritek	'0603
2	R5, R6	1.5M 5% Res.	Meritek	'0603
1	R8	1.0M 5% Res	Meritek	0603
1	R11	10 K 5% Res.	Meritek	'0603
1	R12	402k 1% Res.	Meritek	'0603
1	R15	100 ohm 5% Res.	Meritek	'0603
2	R13, R14	806K 1% Res. 0.063W	Meritek	'0603
1	R16	8.2 5% Res. 1/8W	Meritek	'0603
1	R17	300 ohm 5% Res.	Meritek	'0603
1	R10	10M 5% Res.	Meritek	'0603
1	R19	12M 5% Res. 0.25W	Meritek	'0805
1	R20	1.6M 5% Res.	Meritek	'0805
1	R36	4.7 ohm 5% Res 1/8 W	Meritek	'0603
5	C1, C2, C3, C4, C5	0.1 uf 50V 10% X7R	Tecate	'0805
2	C6, C7	220 pf 2000V NPO 5%	Tecate	1808
1	C8	0.1uf 50V 10% X7R	Tecate	'0805
1	C10	0.001uf 500V10% X7R	Tecate	1206
1	C11	0.47uf 25V Tant 10%	Panasonic	SMD
1	C24	.010 uf 50V 10% X7R	Tecate	0805
1	D1	Bridge Rectifier	Shindengen	N/A
1	SP1	Surge Protection	Teccor	D0-214AA
33	TOTAL			

APPLICATION NOTE

UPGRADING FROM CPC5600 TO CPC5604

5.2 CPC5604 International Schematic

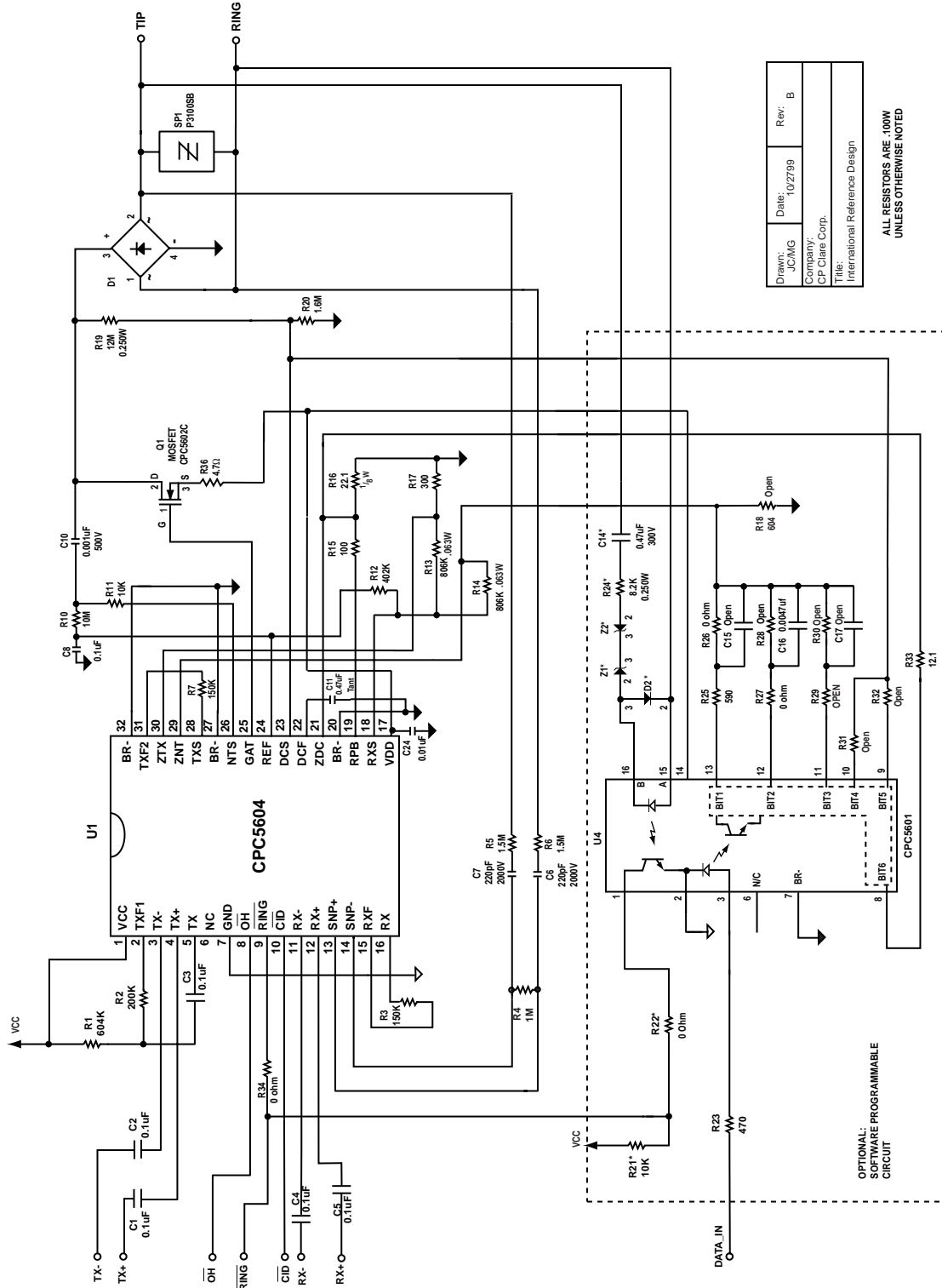

Drawn:	JCM/G	Date:	10/27/99	Rev:	B
Company:	CP Clare Corp.				
Title:	International Reference Design				

ALL RESISTORS ARE 100W UNLESS OTHERWISE NOTED

* Required for external ring detect only.

5.2.1 CPC5604 International BOM

QTY.	Designation	Description	Manufacturer	Package Type
1	U1	CPC5604A	CP Clare	32 Lead SOIC
1	U4	CPC5601D	CP Clare	S016
1	Q1	CPC5602C	CP Clare	SOT-223
1	R1	604k 1% Res.	Meritek	'0603
1	R18	604 ohm 1% Res.	Meritek	'0603
1	R2	200k 5% Res.	Meritek	'0603
1	R4	1M 5% Res.	Meritek	0603
2	R3, R7	150k 5% Res.	Meritek	'0603
2	R5, R6	1.5M 5% Res.	Meritek	'0603
1	R11	10 K 5% Res.	Meritek	'0603
1	R12	402k 1% Res.	Meritek	'0603
1	R15	100 ohm 5% Res.	Meritek	'0603
2	R13, R14	806K 1% Res. 0.063W	Meritek	'0603
1	R16	22.1 5% Res. 1/8W	Meritek	'0603
1	R17	300 ohm 5% Res.	Meritek	'0603
1	R10	10M 5% Res.	Meritek	'0603
1	R19	12M 5% Res. 0.25W	Meritek	'0805
1	R20	1.6M 5% Res.	Meritek	'0805
1	R23	470 ohm 5% Res.	Meritek	'0603
1	R24	8.2k 5% Res. 0.25W	Meritek	'0603
4	R29, R30, R31, R32	Open	-	'0603
1	R25	590 ohm 5% Res.	Meritek	'0603
1	R26	0 ohm Res.	Meritek	'0603
1	R27	0 ohm Res.	Meritek	'0603
1	R28	Open	-	'0603
1	R33	16.5 ohm 5% Res.	Meritek	'0603
1	R34	0 ohm Res.	Meritek	'0603
1	R36	4.7 ohm 5% Res 1/8W	Meritek	'0603
5	C1, C2, C3, C4, C5	0.1 uf 50V 10% X7R	Tecate	'0805
2	C6, C7	220 pf 2000V NPO 5%	Tecate	1808
1	C8	0.1uf 50V 10% X7R	Tecate	'0805
1	C10	0.001uf 500V10% X7R	Tecate	1206
1	C11	0.47uf 25V Tant 10%	Panasonic	SMD
1	C14	.47uf 300V	Tecate	1812
1	C15	Open	-	'0805
1	C16	0.0047 uf 50V 10% X7R	Tecate	'0805
1	C17	Open for future use	-	'0805
1	C24	0.01uf 50V 10% X7R	Tecate	0805
1	SP1	Surge Protection	Teccor	D0-214AA
2	Z1, Z2	Zener 20V	Rohm	SOT-23
1	D1	Bridge Rectifier	Shindengen	N/A
1	D2	Diode BAS16	Rohm	SOT-23
51	TOTAL			

APPLICATION NOTE

UPGRADING FROM CPC5600 TO CPC5604

5.3 CPC5604 CTR21 Schematic

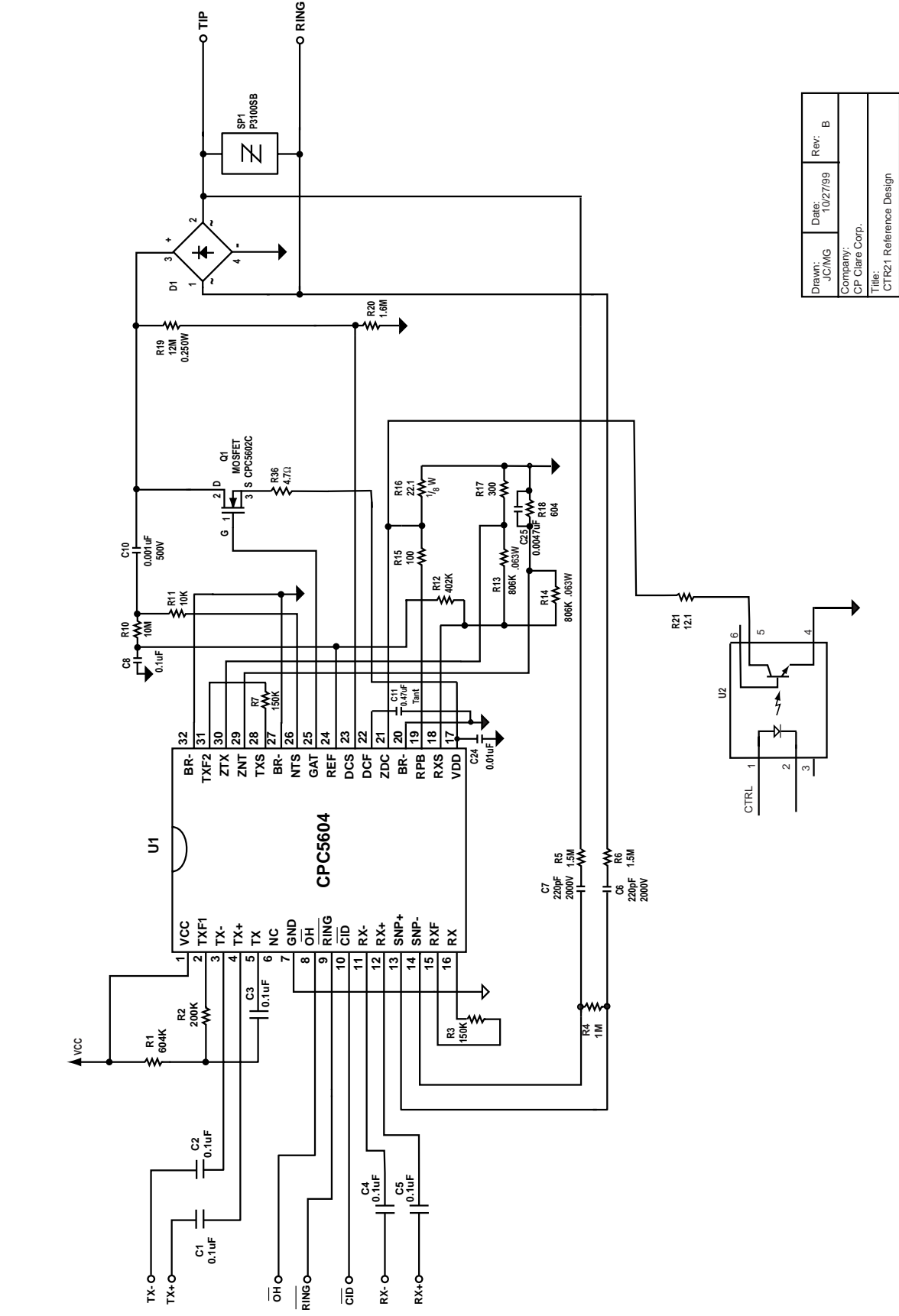

Drawn:	JC/MG	Date:	10/27/99	Rev:	B
Company:	CP Clare Corp.				
Title:	CTR21 Reference Design				

ALL RESISTORS ARE .100W
UNLESS OTHERWISE NOTED

5.3.1 CPC5604 CTR21 BOM

QTY.	Designation	Description	Manufacturer	Package Type
1	U1	CPC5604A	CP Clare	32 Lead SOIC
1	Q1	CPC5602C	CP Clare	SOT-223
1	R1	604k 1% Res.	Meritek	'0603
1	R4	1M 5% Res.	Meritek	0603
1	R18	604 ohms 1% Res.	Meritek	'0603
1	R2	200k 5% Res.	Meritek	'0603
2	R3, R7	150k 5% Res.	Meritek	'0603
2	R5, R6	1.5M 5% Res.	Meritek	'0603
1	R11	10 K 5% Res.	Meritek	'0603
1	R12	402k 1% Res.	Meritek	'0603
1	R15	100 ohm 5% Res.	Meritek	'0603
2	R13, R14	806K 1% Res. 0.063W	Meritek	'0603
1	R16	22.1 5% Res. 1/8W	Meritek	'0603
1	R17	300 ohm 5% Res.	Meritek	'0603
1	R10	10M 5% Res.	Meritek	'0603
1	R19	12M 5% Res. .25W	Meritek	'0805
1	R20	1.6M 5% Res.	Meritek	'0805
1	R21	16.5 5% Res. 0.063W	Meritek	'0603
1	R36	4.7 ohm 5% Res 1/8W	Meritek	'0603
5	C1, C2, C3, C4, C5	0.1 uf 50V 10% X7R	Tecate	'0805
2	C6, C7	220 pf 2000V NPO 5%	Tecate	1808
1	C8	0.1uf 50V 10% X7R	Tecate	'0805
1	C10	0.001uf 500V10% X7R	Tecate	1206
1	C11	0.47uf 25V Tant 10%	Panasonic	SMD
1	C24	0.01uf 50V 10% X7R	Tecate	'0805
1	C25	0.0047uf 50V 10% X7R	Tecate	'0805
1	D1	Bridge Rectifier	Shindengen	N/A
1	SP1	Surge Protection	Teccor	D0-214AA
1	U2	4N35		
35	TOTAL			



APPLICATION NOTE

UPGRADING FROM CPC5600 TO CPC5604

5.4 CPC5604 CTR21 with exceptions Schematic

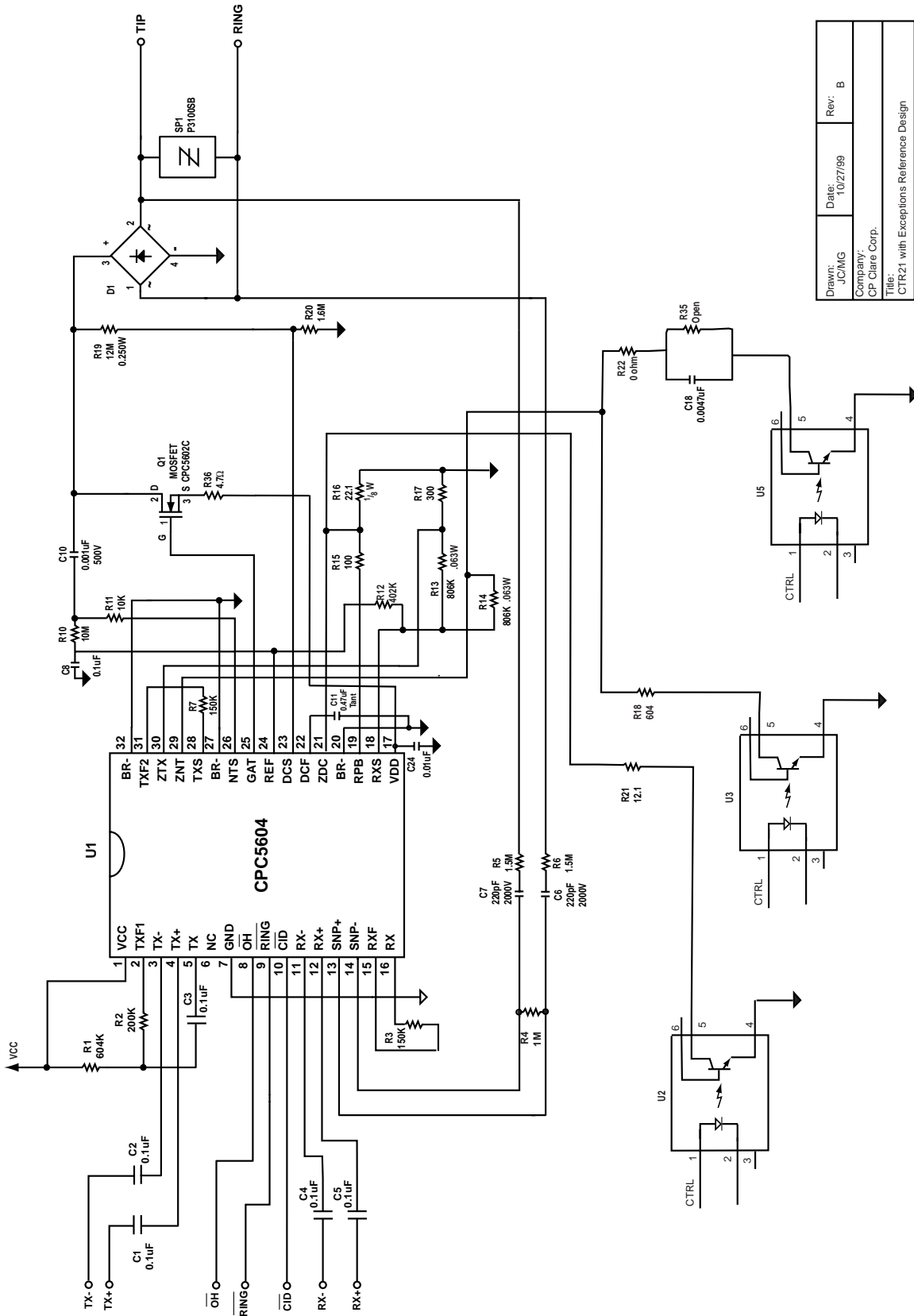

Drawn:	JCM/MS	Date:	10/27/99	Rev:	B
Company:	CP Clare Corp.				
Title:	CTR21 with Exceptions Reference Design				

ALL RESISTORS ARE 100W UNLESS OTHERWISE NOTED

5.4.1 CPC5604 CTR21 with exceptions BOM

QTY.	Designation	Description	Manufacturer	Package Type
1	U1	CPC5604A	CP Clare	32 Lead SOIC
1	Q1	CPC5602C	CP Clare	SOT-223
1	R1	604k 1% Res.	Meritek	'0603
1	R18	604 ohm 1% Res.	Meritek	'0603
1	R2	200k 5% Res.	Meritek	'0603
1	R4	1M 5% Res	Meritek	0603
2	R3, R7	150k 5% Res.	Meritek	'0603
2	R5, R6	1.5M 5% Res.	Meritek	'0603
1	R11	10 K 5% Res.	Meritek	'0603
1	R12	402k 1% Res.	Meritek	'0603
1	R15	100 ohm 5% Res.	Meritek	'0603
2	R13, R14	806K 1% Res. 0.063W	Meritek	'0603
1	R16	22.1 5% Res. 1/8W	Meritek	'0603
1	R17	300 ohm 5% Res.	Meritek	'0603
1	R10	10M 5% Res.	Meritek	'0603
1	R19	12M 5% Res. 0.25W	Meritek	'0805
1	R20	1.6M 5% Res.	Meritek	'0805
1	R21	16.5 5% Res. 0.063W	Meritek	'0603
1	R22	0 ohm	Meritek	'0603
1	R35	Open	-	'0603
1	R36	4.7 ohm 5% Res 1/8W	Meritek	'0603
5	C1, C2, C3, C4, C5	0.1 uf 50V 10% X7R	Tecate	'0805
2	C6, C7	220 pf 2000V NPO 5%	Tecate	1808
1	C8	0.1 uf 50V 10% X7R	Tecate	'0805
1	C10	0.001uf 500V10% X7R	Tecate	1206
1	C11	0.47uf 25V Tant 10%	Panasonic	SMD
1	C18	0.0047uF 50V 10% X7R	Tecate	'0805
1	C24	0.01uf 50V 10% X7R	Tecate	0805
1	D1	Bridge Rectifier	Shindengen	N/A
1	SP1	Surge Protection	Teccor	DO-214AA
1	U2	4N35		
1	U3	4N35		
1	U5	4N35		
39	TOTAL			

APPLICATION NOTE

UPGRADING FROM CPC5600 TO CPC5604

5.5 CPC5604 Lucent Reference design

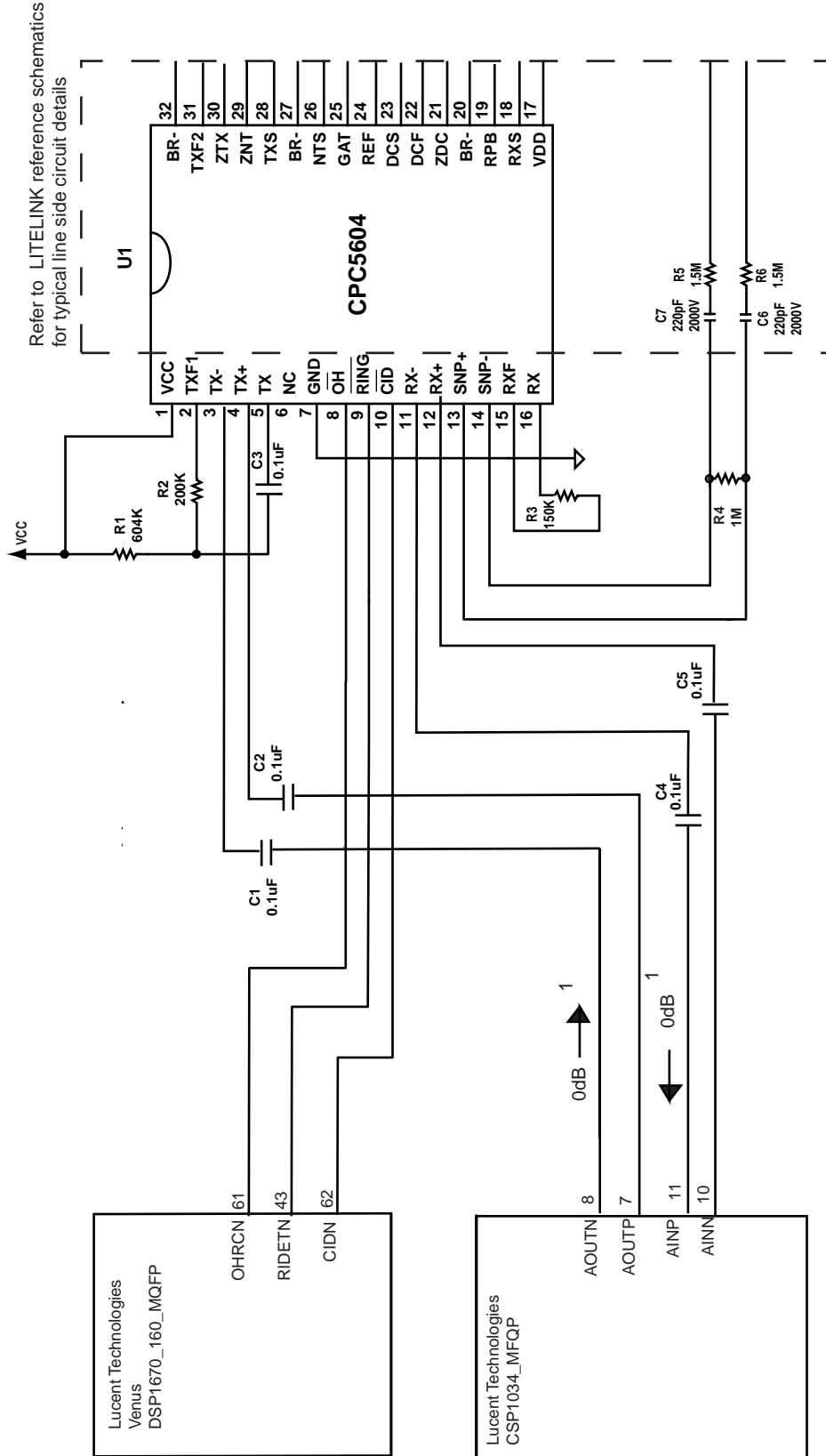

Drawn: SM	Date: 6/24/99	Rev: A
Company: CP Clare Corp.		
Title: Interconnection To Lucent (CPC5600A1X)		

ALL RESISTORS ARE .100W UNLESS OTHERWISE NOTED

1. Lucent chips expect a zero dB drop between the codec and Tip and Ring.

5.6 CPC5604 Conexant Reference design

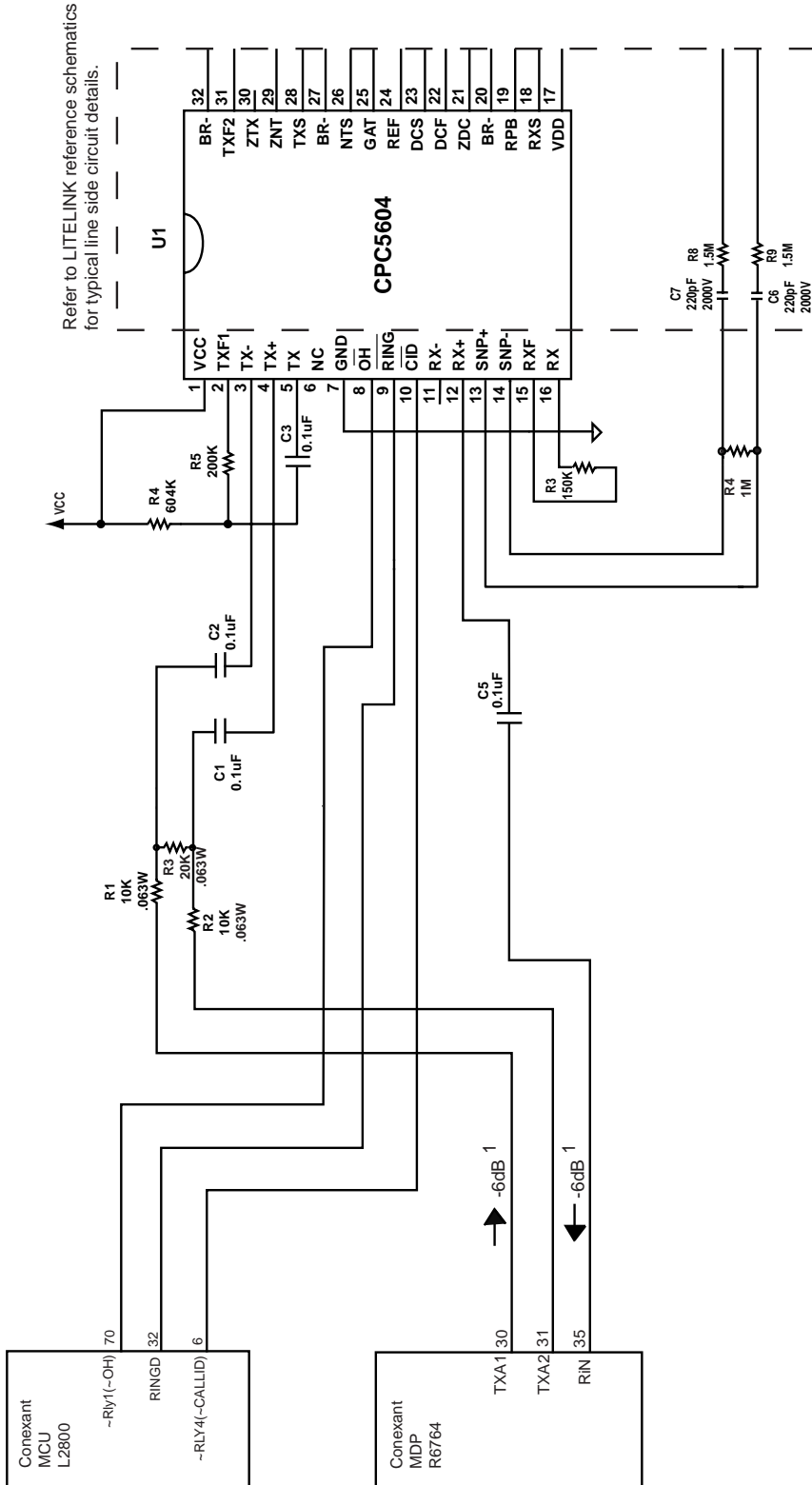

Drawn: SM	Date: 6/24/99	Rev: A
Company: CP Clare Corp.		
Title: Interconnection to Conexant(Rockwell) (CPC5600A1X)		

ALL RESISTORS ARE .100W
UNLESS OTHERWISE NOTED

Interconnection diagram is based on the Conexant(Rockwell) RC56D Chip solution.
1. Conexant Chipsets rely on a 6dB loss between MDP and tip and ring. This is solved by placing the R1, R2, R3, resistor circuit in the Transmit Path and the use of a single end of the differential receive.



CLARE

Worldwide Sales Offices

NORTH AMERICA

North American Sales Office

Clare
78 Cherry Hill Drive
Beverly, MA 01915
Tel: 1-978-524-6700
Fax: 1-978-524-4900
Toll Free: 1-800-272-5273

Eastern Regional Sales

Clare
78 Cherry Hill Drive
Beverly, MA 01915
Tel: 1-978-524-6700
Fax: 1-978-524-4900
Toll Free: 1-800-272-5273

Mid-American Regional Sales

Clare
78 Cherry Hill Drive
Beverly, MA 01915
Tel: 1-978-524-6700
Fax: 1-978-524-4900
Toll Free: 1-800-272-5273

Northwestern Regional Sales

Clare
2010 Crow Canyon Place
Suite 100
San Ramon, CA 94583
Tel: 1-925-277-3422
Fax: 1-925-277-3423
Toll Free: 1-800-272-5273

Southwestern Regional Sales

Clare
2816 Nevis Circle
Costa Mesa, CA 92626
Tel: 1-714-556-3661
Fax: 1-714-546-4254
Toll Free: 1-800-272-5273

Canadian Regional Sales

Clare Canada Ltd.
3425 Harvester Road
Suite 202
Burlington, Ontario L7N 3N1
Tel: 1-905-333-9066
Fax: 1-905-333-1824

EUROPE

European Sales Office

CP Clare nv
Bampslaan 17
B-3500 Hasselt (Belgium)
Tel: 32-11-300868
Fax: 32-11-300890

France

CP Clare France
31 Cours des Juilliottes
94700 Maisons Alfort
France
Tel: 33 (1) 56-29-14-14
Fax: 33 (1) 56-29-14-15

Germany

CP Clare Elektronik GmbH
Leonberger Strasse 20
D-71638, Ludwigsburg
Tel: 49-7141-9543-0
Fax: 49-7141-9543-20

Italy

C.L.A.R.E.s.a.s.
Via C. Colombo 10/A
I-20066 Melzo (Milano)
Tel: 39-02-95737160
Fax: 39-02-95738829

Sweden

Clare Sales
Comptronic AB
Box 167
S-16329 Spånga
Tel: 46-862-10370
Fax: 46-862-10371

United Kingdom

Clare UK Sales
Marco Polo House
Cook Way
Bindon Road
Taunton
UK-Somerset TA2 6BG
Tel: 44-1-823 352541
Fax: 44-1-823 352797

ASIA PACIFIC

Asian Sales Office

Clare
Room N1016, Chia-Hsin, Bldg II,
10F, No. 96, Sec. 2
Chung Shan North Road
Taipei, Taiwan R.O.C.
Tel: 886-2-2523-6368
Fax: 886-2-2523-6369

JAPAN

Japanese Sales Office

Clare
Tosei Building 5F
2-23-1, Ikebukuro, Toshima-ku
Tokyo 171
Tel: 03-3980-2212
Fax: 03-3980-2213

HEADQUARTERS

Clare
78 Cherry Hill Drive
Beverly, MA 01915
Tel: 1-978-524-6700
Fax: 1-978-524-4900
Toll Free: 1-800-272-5273

<http://www.clare.com>

Clare makes no assertion or warranty that the circuitry and the uses thereof disclosed herein are non-infringing on any valid US or foreign patents. CP Clare assumes no liability as a result of the use of said specifications and reserves the right to make changes to specifications without notice. CP Clare does not authorize or warrant any CP Clare device for use in life support devices and/or systems. Contact your nearest CP Clare Sales Office for the latest specifications.

Protected by U.S. Patent #5,946,394

Specification: AN-CPC5600/CPC5604-R1
© Copyright 1999, Clare
All rights reserved. Printed in USA.
11/2/99