

Contents

Part 1 Product Overview

1. Description .....	2
2. Pin Configuration .....	3
3. Notes .....	4
4. Truth Table .....	5
5. Block Diagram .....	5
6. Absolute Maximum Ratings .....	6
7. Recommended DC Operating Conditions .....	6
8. Pin Capacitance .....	6
9. DC Electrical Characteristics .....	7

Part 2 Flash Memory Specifications

1. Introduction .....	9
2. Principles of Operation .....	12
3. Bus Operation .....	14
4. Command Definitions .....	15
5. Design Considerations .....	25
6. Electrical Specifications .....	27

Part 3 SRAM Specifications

1. Description .....	40
2. Truth Table .....	41
3. Block Diagram .....	41
4. Absolute Maximum Ratings .....	42
5. Recommended DC Operating Conditions .....	42
6. DC Electrical Characteristics .....	42
7. AC Electrical Characteristics .....	43
8. Timing Chart .....	44

Part 4 Package and packing specification .....	46
--	----



## Part 1 Overview

### 1. Description

The LRS1306 is a combination memory organized as 524,288×16 bit flash memory and 262,144×8 bit static RAM in one package. It is fabricated using silicon-gate CMOS process technology.

### Features

#### ○ Access Time

Flash memory access time	. . . .	120 ns Max.
SRAM access time	. . . .	85 ns Max.

#### ○ Operating current

Flash memory Read	. . . .	25 mA Max.	( $t_{CYCLE}=200ns$ )
Word write	. . . .	57 mA Max.	( $F-V_{CC} \geq 3.0V$ )
Block erase	. . . .	42 mA Max.	( $F-V_{CC} \geq 3.0V$ )
SRAM Operating	. . . .	25 mA Max.	( $t_{CYCLE}=200ns$ )

#### ○ Standby current

Flash memory	. . . .	25 $\mu A$ Max.	( $F-\overline{CE} \geq F-V_{CC}-0.2V$ , $F-\overline{RP} \leq 0.2V$ , $F-V_{PP} \leq 0.2V$ )
SRAM	. . . .	120 $\mu A$ Max.	( $S-\overline{CE} \geq S-V_{CC}-0.2V$ )
		1.0 $\mu A$ Typ.	( $T_a=25^\circ C$ , $S-V_{CC}=3V$ , $S-\overline{CE} \geq S-V_{CC}-0.2V$ )

(Total standby current is the summation of Flash memory's standby current and SRAM's one.)

- Power supply . . . . 2.7V to 3.6V
- Operating temperature . . . . -40°C to +85°C

(Block erase and word write operations of Flash memory with  $T_a < -30^\circ C$  are not supported.)

- Fully static operation
- Three-state output
- Not designed or rated as radiation hardened
- 48 pin TSOP (TSOP48-P-1014) plastic package
- Flash memory has P-type bulk silicon, and SRAM has N-type bulk silicon.

## 2.Pin Configuration

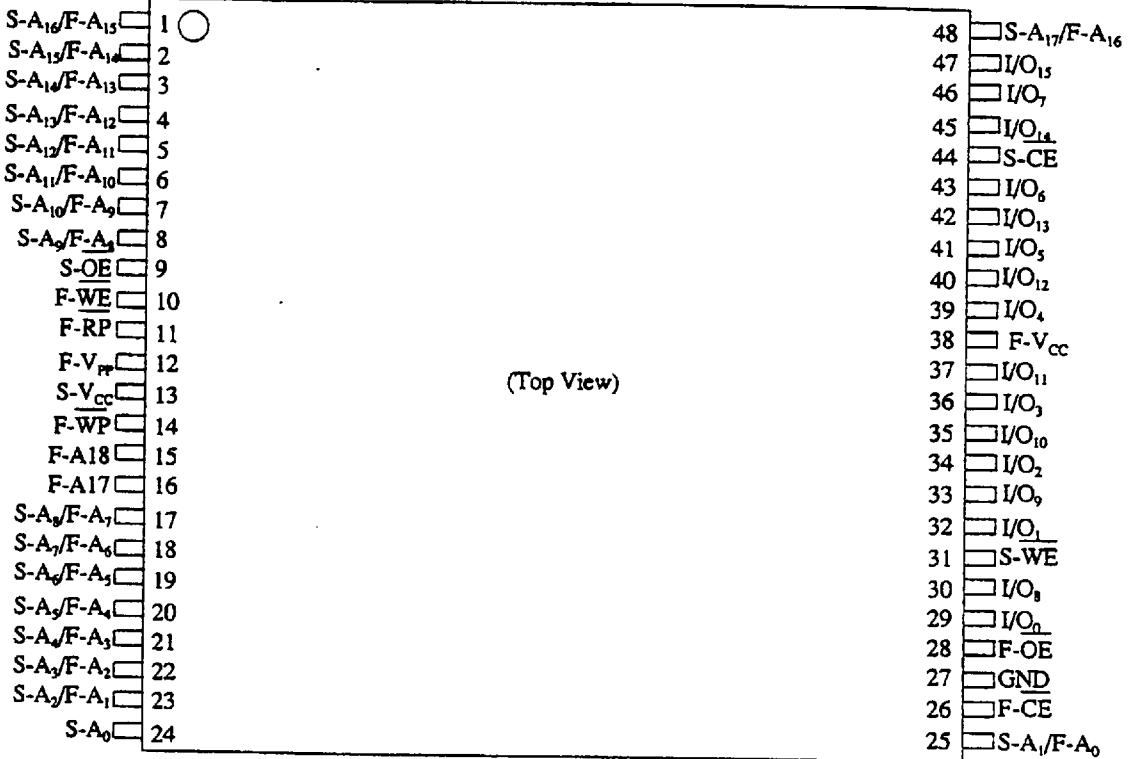

PIN	DESCRIPTION
S-A <sub>1</sub> /F-A <sub>0</sub> to S-A <sub>17</sub> /F-A <sub>16</sub>	Common Address Input Pins
S-A <sub>0</sub>	Address Input Pin for SRAM
F-A <sub>17</sub> to F-A <sub>18</sub>	Address Input Pins for Flash Memory
F-CE	Chip Enable Input Pin for Flash Memory
S-CE	Chip Enable Input Pin for SRAM
F-WE	Write Enable Input Pin for Flash Memory
S-WE	Write Enable Input Pin for SRAM
F-OE	Output Enable Input Pin for Flash Memory
S-OE	Output Enable Input Pin for SRAM
I/O <sub>0</sub> to I/O <sub>7</sub>	Common Data Input/Output Pins
I/O <sub>8</sub> to I/O <sub>15</sub>	Data Input/Output Pins for Flash Memory
F-RP	Reset/Deep Power Down Input Pin for Flash Memory
F-WP	Write Protect Pin for Flash Memory's Boot Block
F-V <sub>CC</sub>	Power Supply Pin for Flash Memory
F-V <sub>PP</sub>	Power Supply Pin for Flash Memory Write/Erase
S-V <sub>CC</sub>	Power Supply Pin for SRAM
GND	Common GND

### 3. Notes

This product is a stacked TSOP package that a 8M(x16) bit Flash Memory and a 2M(x8) bit SRAM are assembled into.

#### POWER SUPPLY AND CHIP ENABLE OF FLASH MEMORY AND SRAM

It is forbidden that both  $\overline{F-CE}$  and  $\overline{S-CE}$  should be LOW simultaneously. If the two memories are active together, possibly they may not operate normally by interference noises or data collision on I/O bus. Both  $F-V_{CC}$  and  $S-V_{CC}$  are needed to be applied by the recommended supply voltage at the same time.

#### POWER UP SEQUENCE

When turning on Flash memory power supply, keep  $\overline{RP}$  LOW. After  $F-V_{CC}$  reaches over 2.7V, keep  $\overline{RP}$  LOW for more than 100nsec.

#### DEVICE DECOUPLING

The power supply is needed to be designed carefully because one of the SRAM and the Flash Memory is in standby mode when the other is active. A careful decoupling of power supplies is necessary between SRAM and Flash Memory. Note peak current caused by transition of control signals( $\overline{F-CE}$ ,  $\overline{S-CE}$ ).

4. Truth table(\*1,3)

F- $\overline{CE}$	F- $\overline{OE}$	F- $\overline{WE}$	F- $\overline{RP}$	S- $\overline{CE}$	S- $\overline{OE}$	S- $\overline{WE}$	Address	Mode	I/O <sub>0</sub> to I/O <sub>7</sub>	Current	Note
L	L	H	H	H	X	X	X	Flash read	Output	I <sub>CC</sub>	*2,7
L	H	H	H	H	X	X	X	Flash read	High-Z	I <sub>CC</sub>	
L	H	L	H	H	X	X	X	Flash write	Input	I <sub>CC</sub>	*5,6,7
H	X	X	X	L	L	H	X	SRAM read	Output	I <sub>CC</sub>	
H	X	X	X	L	H	H	X	SRAM read	High-Z	I <sub>CC</sub>	
H	X	X	X	L	X	L	X	SRAM write	Input	I <sub>CC</sub>	
H	X	X	H	H	X	X	X	Standby	High-Z	I <sub>SB</sub>	
H	X	X	L	H	X	X	X	Deep power down	High-Z	I <sub>SB</sub>	*4

Notes:

- \* 1. Do not make F- $\overline{CE}$  and S- $\overline{CE}$  "LOW" level at the same time.
- \* 2. Refer to DC Characteristics. When F-V<sub>PP</sub> ≤ V<sub>PPLK</sub>, memory contents can be read, but not altered.
- \* 3. X can be V<sub>IL</sub> or V<sub>IH</sub> for control pins and addresses, and V<sub>PPLK</sub> or V<sub>PPH</sub> for F-V<sub>PP</sub>. See DC Characteristics for V<sub>PPLK</sub> and V<sub>PPH</sub> voltages.
- \* 4. F- $\overline{RP}$  at GND ± 0.2V ensures the lowest deep power-down current.
- \* 5. Command writes involving block erase, write, or lock-bit configuration are reliably executed when F-V<sub>PP</sub> = V<sub>PPH</sub> and F-V<sub>CC</sub> = V<sub>CC1</sub>. Block erase or word write operations with V<sub>IH</sub> < F- $\overline{RP}$  < V<sub>IH</sub> or Ta < -30°C produce spurious results and should not be attempted.
- \* 6. Refer to Part 2 Section 3 Table 4 for valid DIV during a write operation.
- \* 7. Do not use in a timing that both F- $\overline{OE}$  and F- $\overline{WE}$  is "LOW" level.

5. Block Diagram

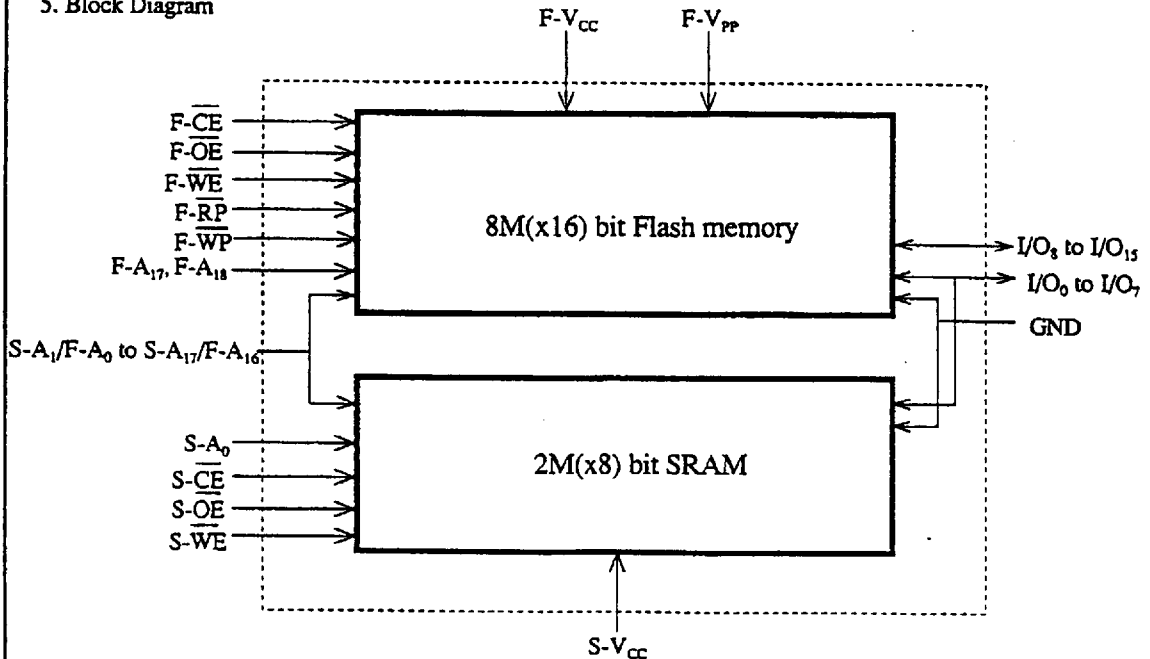

The contents described in Part 1 take first priority over Part 2 and Part 3.

### 6. Absolute Maximum Ratings

Parameter	Symbol	Ratings	Unit
Supply voltage(*8,9)	$V_{CC}$	-0.2 to 4.6	V
Input voltage(*8,10)	$V_{IN}$	-0.3 (*11) to $V_{CC}+0.3$	V
Operating temperature	$T_{OP}$	-40 to +85	°C
Storage temperature	$T_{STG}$	-65 to +125	°C
$V_{PP}$ voltage(*8)	$V_{PP}$	-0.2 to +12.6(*12)	V
Input voltage(*8)	$\overline{RP}$	-0.5(*11) to +12.6(*12)	V

- Notes) \*8. The maximum applicable voltage on any pin with respect to GND.  
 \*9. Except  $V_{PP}$ .  
 \*10. Except  $\overline{RP}$ .  
 \*11. -2.0V undershoot is allowed when the pulse width is less than 20nsec.  
 \*12. +14.0V overshoot is allowed when the pulse width is less than 20nsec.

### 7. Recommended DC Operating Conditions

( $T_a = -40^\circ\text{C}$  to  $+85^\circ\text{C}$ )

Parameter	Symbol	Min.	Typ.	Max.	Unit
Supply voltage	$V_{CC}$	2.7	3.0	3.6	V
Input voltage	$V_{IH}$	2.0		$V_{CC}+0.3(*15)$	V
	$V_{IL}$	-0.3(*13)		0.8	V
	$V_{HH}(*14)$	11.4		12.6	

- Notes) \*13. -2.0V undershoot is allowed when the pulse width is less than 20nsec.  
 \*14. This voltage is applicable to F- $\overline{RP}$  Pin only.  
 \*15.  $V_{CC}$  is the lower one of S- $V_{CC}$  and F- $V_{CC}$ .

### 8. Pin Capacitance

( $T_a = 25^\circ\text{C}$ ,  $f = 1\text{MHz}$ )

Parameter	Symbol	Condition	Min.	Typ.	Max.	Unit
Input capacitance	$C_{IN}$	$V_{IN} = 0V$			20	pF *16
I/O capacitance	$C_{IO}$	$V_{IO} = 0V$			22	pF *16

Note) \*16. Sampled but not 100% tested

9.DC Electrical Characteristics

( $T_a = -40^\circ\text{C}$  to  $+85^\circ\text{C}$ ,  $V_{CC} = 2.7\text{V}$  to  $3.6\text{V}$ )

Parameter	Note	Conditions	Min.	Typ. (*17)	Max.	Unit
Input leakage current ( $I_{LI}$ )		$V_{IN} = 0\text{V}$ to $V_{CC}$	-1.5		1.5	$\mu\text{A}$
Output leakage current ( $I_{LO}$ )		$\overline{F-CE}$ , $\overline{S-CE} = V_{IH}$ or $\overline{F-OE}$ , $\overline{S-OE} = V_{IH}$ or $\overline{F-WE}$ , $\overline{S-WE} = V_{IH}$ , $V_{IO} = 0\text{V}$ to $V_{CC}$	-1.5		1.5	$\mu\text{A}$
Operating supply current ( $I_{CC}$ )	FLASH	*18	Read current, $F-V_{PP} \leq F-V_{CC}$ $\overline{F-CE} \leq 0.2\text{V}$ , $V_{IN} \geq V_{CC} - 0.2\text{V}$ or $V_{IN} \leq 0.2\text{V}$	$t_{CYCLE} = 200\text{ns}$ $I_{IO} = 0\text{mA}$	25.2	$\text{mA}$
		*19 *20	Summation of $V_{CC}$ Byte Write or set lock-bit current, and $V_{PP}$ Byte Write or set lock-bit current. $F-V_{CC} \geq 3.0\text{V}$		57	$\text{mA}$
		*19 *21	Summation of $V_{CC}$ Block Erase or Clear Block lock-bits current, and $V_{PP}$ Block Erase or Clear Block lock-bits current. $F-V_{CC} \geq 3.0\text{V}$		42	$\text{mA}$
	SRAM	*22	$\overline{S-CE} = 0.2\text{V}$ , $V_{IN} \geq V_{CC} - 0.2\text{V}$ or $V_{IN} \leq 0.2\text{V}$	$t_{CYCLE} = 200\text{ns}$ $I_{IO} = 0\text{mA}$	25	$\text{mA}$
Standby current ( $I_{SB}$ )	FLASH	*23	$\overline{F-CE} = V_{IH}$ , $\overline{RP} = V_{IH}$		2.2	$\text{mA}$
		*24	$\overline{F-CE} \geq V_{CC} - 0.2\text{V}$ , $F-V_{PP} \leq 0.2\text{V}$ , $\overline{RP} \leq 0.2\text{V}$		25	$\mu\text{A}$
	SRAM	*25	$\overline{S-CE} = V_{IH}$		3.0	$\text{mA}$
		*26	$\overline{S-CE} \geq V_{CC} - 0.2\text{V}$		1.0	120 $\mu\text{A}$
Output voltage ( $V_{OL}$ , $V_{OH}$ )		$I_{OL} = 2.0\text{mA}$			0.4	$\text{V}$
		$I_{OH} = -2.0\text{mA}$	2.4			$\text{V}$

Note) \*17.  $T_a = 25^\circ\text{C}$ ,  $V_{CC} = 3.0\text{V}$

- \*18. This value is read current ( $I_{CCR} + I_{PPR}$ ) of the flash memory.
- \*19. Sampled but not 100% tested.
- \*20. This value is operation current ( $I_{CCW} + I_{PPW}$ ) of flash memory.
- \*21. This value is operation current ( $I_{CCB} + I_{PPE}$ ) of flash memory.
- \*22. This value is operation current ( $I_{CC1}$ ) of SRAM.
- \*23. This value is stand-by current ( $I_{CCS} + I_{PPS}$ ) of flash memory.
- \*24. This value is deep power down current ( $I_{CCD} + I_{PPD}$ ) of flash memory.
- \*25. This value is stand-by current ( $I_{SB1}$ ) of SRAM.
- \*26. This value is stand-by current ( $I_{SB}$ ) of SRAM.

PART2 Flash memory  
CONTENTS

	PAGE		PAGE
1.0 INTRODUCTION.....	9	5.0 DESIGN CONSIDERATIONS.....	25
1.1 New Features .....	9	5.1 Three-Line Output Control.....	25
1.2 Product Overview .....	9	5.2 Power Supply Decoupling.....	25
2.0 PRINCIPLES OF OPERATION .....	12	5.3 V <sub>pp</sub> Trace on Printed Circuit Boards.....	25
2.1 Data Protection .....	12	5.4 V <sub>CC</sub> , V <sub>PP</sub> , $\overline{RP}$ Transitions .....	26
3.0 BUS OPERATION .....	14	5.5 Power-Up/Down Protection.....	26
3.1 Read.....	14	5.6 Power Dissipation.....	26
3.2 Output Disable.....	14	6.0 ELECTRICAL SPECIFICATIONS .....	27
3.3 Standby .....	14	6.1 Absolute Maximum Ratings.....	27
3.4 Deep Power-Down.....	14	6.2 Operating Conditions.....	28
3.5 Read Identifier Codes Operation.....	15	6.2.1 AC Input/Output Test Conditions.....	28
3.6 Write.....	15	6.2.2 DC Characteristics.....	29
4.0 COMMAND DEFINITIONS.....	15	6.2.3 AC Characteristics - Read-Only Operations..	31
4.1 Read Array Command.....	17	6.2.4 AC Characteristics for $\overline{WE}$ Controlled Write	
4.2 Read Identifier Codes Command.....	17	Operations.....	33
4.3 Read Status Register Command .....	17	6.2.5 AC Characteristics for $\overline{CE}$ -Controlled Write	
4.4 Clear Status Register Command.....	17	Operations.....	35
4.5 Block Erase Command.....	17	6.2.6 Reset Operations .....	37
4.6 Word Write Command .....	18	6.2.7 Block Erase and Word Write Performance....	38
4.7 Block Erase Suspend Command.....	18		
4.8 Word Write Suspend Command.....	19		



## 1 INTRODUCTION

This datasheet contains LRS13061 specifications. Section 1 provides a flash memory overview. Sections 2, 3, 4, and 5 describe the memory organization and functionality. Section 6 covers electrical specifications.

### 1.1 New Features

The LRS13061 Flash memory maintains backwards-compatibility with SHARP's LH 28F800BG-L.

- Smart Voltage Technology
- Enhanced Suspend Capabilities
- Boot Block Architecture

Please note following important differences:

- $V_{PPLK}$  has been lowered to 1.5V to support 2.7V block erase and word write operations. Designs that switch  $V_{PP}$  off during read operations should make sure that the  $V_{PP}$  voltage transitions to GND.
- Allow  $V_{PP}$  connection to 2.7V.

### 1.2 Product Overview

The LRS13061 is a high-performance 8-Mbit Smart Voltage Flash memory organized as 512 Kword of 16 bits. The 512 Kword of data is arranged in two 4K-word boot blocks, six 4K-word parameter blocks and fifteen 32K-word main blocks which are individually erasable in-system. The memory map is shown in Figure 2.

SmartVoltage technology provides a choice of  $V_{CC}$  and  $V_{PP}$  combinations, as shown in Table 1, to meet system performance and power expectations. In addition to flexible erase and program voltages, the dedicated  $V_{PP}$  pin gives complete data protection when  $V_{PP} \leq V_{PPLK}$ .

Table 1.  $V_{CC}$  and  $V_{PP}$  Voltage Combinations

$V_{CC}$ Voltage	$V_{PP}$ Voltage
2.7V to 3.6V	2.7V to 3.6V

Internal  $V_{CC}$  and  $V_{PP}$  detection circuitry automatically configures the device for optimized read and write operations.

A Command User Interface (CUI) serves as the interface between the system processor and internal operation of the device. A valid command sequence written to the CUI initiates device automation. An internal Write State Machine (WSM) automatically executes the algorithms and timings necessary for block erase and word write operations.

A block erase operation erases one of the device's 32K-word blocks typically within 1.14sec., 4K-word blocks typically within 0.38sec. independent of other blocks. Each block can be independently erased 100,000 times. Block erase suspend mode allows system software to suspend block erase to read or write data from any other block.

Writing memory data is performed in word increments of the device's 32K-word blocks typically within 44.6 $\mu$ s, 4Kword blocks typically within 45.9 $\mu$ s. Word write suspend mode enables the system to read data or execute code from any other flash memory array location.

The boot blocks can be locked for the  $\overline{WP}$  pin. Block erase or word write for boot block must not be carried out by  $\overline{WP}$  to Low and  $\overline{RP}$  to  $V_{IH}$ .

The status register indicates when the WSM's block erase or word write operation is finished.

The access time is 120ns ( $t_{AVQV}$ ) over the commercial temperature range (-40°C to +85°C) and  $V_{CC}$  supply voltage range of 2.7V-3.6V.

The Automatic Power Savings (APS) feature substantially reduces active current when the device is in static mode (addresses not switching). In APS mode, the typical  $I_{CCR}$  current is 1 mA at 3.3V  $V_{CC}$ .

When  $\overline{CE}$  and  $RP$  pins are at  $V_{CC}$ , the  $I_{CC}$  CMOS standby mode is enabled. When the  $RP$  pin is at GND, deep power-down mode is enabled which minimizes power consumption and provides write protection during reset. A reset time ( $t_{PHQV}$ ) is required from  $RP$  switching high until outputs are valid. Likewise, the device has a wake time ( $t_{PHEL}$ ) from  $RP$ -high until writes to the CUI are recognized. With  $RP$  at GND, the WSM is reset and the status register is cleared.

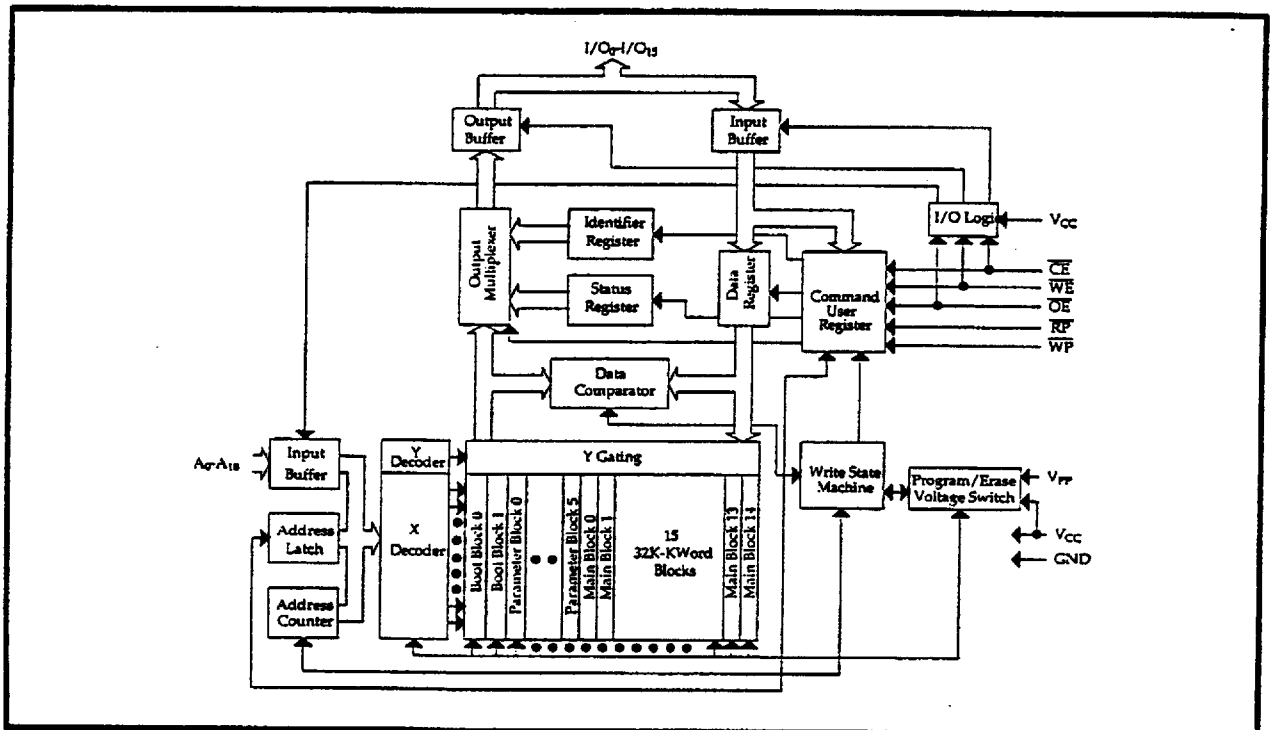

Figure 1. Block Diagram

Table 2. Pin Descriptions

Sym	Type	Name and Function
$A_0$ - $A_{18}$ (*1)	INPUT	ADDRESS INPUTS: Inputs for addresses during read and write operations. Addresses are internally latched during a write cycle.
$I/O_0$ - $I/O_{15}$	INPUT/ OUTPUT	DATA INPUT/OUTPUTS: Inputs data and commands during CUI write cycles; outputs data during memory array, status register, and identifier code read cycles. Data pins float to high-impedance when the chip is deselected or outputs are disabled. Data is internally latched during a write cycle.
$\overline{CE}$ (*2)	INPUT	CHIP ENABLE: Activates the device's control logic, input buffers, decoders, and sense amplifiers. $\overline{CE}$ -high deselects the device and reduces power consumption to standby levels.
$\overline{RP}$	INPUT	RESET/DEEP POWER-DOWN: Puts the device in deep power-down mode and resets internal automation. $\overline{RP}$ -high enables normal operation. When driven low, $\overline{RP}$ inhibits write operations which provides data protection during power transitions. Exit from deep power-down sets the device to read array mode. With $\overline{RP}=V_{HH}$ , block erase or word write can operate to all blocks without $\overline{WP}$ state. Block erase or word write with $V_{IH} < \overline{RP} < V_{HH}$ produce spurious results and should not be attempted.
$\overline{OE}$ (*3)	INPUT	OUTPUT ENABLE: Gates the device's outputs during a read cycle.
$\overline{WE}$ (*4)	INPUT	WRITE ENABLE: Controls writes to the CUI and array blocks. Addresses and data are latched on the rising edge of the $\overline{WE}$ pulse.
$\overline{WP}$ (*5)	INPUT	WRITE PROTECT: Master control for boot blocks locking. When $V_{IL}$ , locked boot blocks cannot be erased and programmed.
$V_{PP}$ (*6)	SUPPLY	BLOCK ERASE and WORD WRITE POWER SUPPLY: For erasing array blocks or writing words. With $V_{PP} \leq V_{PPLK}$ , memory contents cannot be altered. Block erase and word write with an invalid $V_{PP}$ (see DC Characteristics) produce spurious results and should not be attempted.
$V_{CC}$ (*7)	SUPPLY	DEVICE POWER SUPPLY: Do not float any power pins. With $V_{CC} \leq V_{LKO}$ , all write attempts to the flash memory are inhibited. Device operations at invalid $V_{CC}$ voltage (see DC Characteristics) produce spurious results and should not be attempted.
GND	SUPPLY	GROUND: Do not float any ground pins.

NOTES:

- \*1.  $A_0$ - $A_{18}$  mean F- $A_0$  to F- $A_{18}$  in the Part 1.
- \*2.  $\overline{CE}$  means F- $\overline{CE}$  in the Part 1.
- \*3.  $\overline{OE}$  means F- $\overline{OE}$  in the Part 1.
- \*4.  $\overline{WE}$  means F- $\overline{WE}$  in the Part 1.
- \*5.  $\overline{WP}$  means F- $\overline{WP}$  in the Part 1.
- \*6.  $V_{PP}$  means F- $V_{PP}$  in the Part 1.
- \*7.  $V_{CC}$  means F- $V_{CC}$  in the Part 1.

## 2 PRINCIPLES OF OPERATION

The LRS13061 Smart Voltage Flash memory includes an on-chip WSM to manage block erase and word write functions. It allows for: 100% TTL-level control inputs, fixed power supplies during block erasure, word write, and minimal processor overhead with RAM-like interface timings.

After initial device power-up or return from deep power-down mode (see Bus Operations), the device defaults to read array mode. Manipulation of external memory control pins allow array read, standby, and output disable operations.

Status register and identifier codes can be accessed through the CUI independent of the  $V_{pp}$  voltage. High voltage on  $V_{pp}$  enables successful block erasure and word writing. All functions associated with altering memory contents—block erase, word write, status, and identifier codes—are accessed via the CUI and verified through the status register.

Commands are written using standard microprocessor write timings. The CUI contents serve as input to the WSM, which controls the block erase and word write. The internal algorithms are regulated by the WSM, including pulse repetition, internal verification, and margining of data. Addresses and data are internally latch during write cycles. Writing the appropriate command outputs array data, accesses the identifier codes or outputs status register data.

Interface software that initiates and polls progress of block erase and word write can be stored in any block. This code is copied to and executed from system RAM during flash memory updates. After successful completion, reads are again possible via the Read Array command. Block erase suspend allows system software to suspend a block erase to read/write data from/to blocks other than that which is suspended. Word write suspend allows system software to suspend a word write to read data from any other flash memory array location.

### 2.1 Data Protection

Depending on the application, the system designer may choose to make the  $V_{pp}$  power supply switchable (available only when memory block erases or word writes are required) or hardwired to  $V_{ppH}$ . The device accommodates either design practice and encourages optimization of the processor-memory interface.

When  $V_{pp} \leq V_{ppLK}$ , memory contents cannot be altered. The CUI, with two-step block erase or word write command sequences, provides protection from unwanted operations even when high voltage is applied to  $V_{pp}$ . All write functions are disabled when  $V_{CC}$  is below the write lockout voltage  $V_{LKO}$  or when  $\overline{RP}$  is at  $V_{IL}$ . The device's boot blocks locking capability for  $\overline{WP}$  provides additional protection from inadvertent code or data alteration by block erase and word write operations.

Top Boot		
7FFF	4K-word Boot Block	0
7F000 7EFFF	4K-word Boot Block	1
7E000 7DFFF	4K-word Parameter Block	0
7D000 7CFFF	4K-word Parameter Block	1
7C000 7BFFF	4K-word Parameter Block	2
7B000 7AFFF	4K-word Parameter Block	3
7A000 79FFF	4K-word Parameter Block	4
79000 78FFF	4K-word Parameter Block	5
78000 77FFF	32K-word Main Block	0
70000 6FFFF	32K-word Main Block	1
68000 67FFF	32K-word Main Block	2
60000 5FFFF	32K-word Main Block	3
58000 57FFF	32K-word Main Block	4
50000 4FFFF	32K-word Main Block	5
48000 47FFF	32K-word Main Block	6
40000 3FFFF	32K-word Main Block	7
38000 37FFF	32K-word Main Block	8
30000 2FFFF	32K-word Main Block	9
28000 27FFF	32K-word Main Block	10
20000 1FFFF	32K-word Main Block	11
18000 17FFF	32K-word Main Block	12
10000 0FFFF	32K-word Main Block	13
08000 07FFF	32K-word Main Block	14
00000		

Figure2. Memory Map

### 3 BUS OPERATION

The local CPU reads and writes flash memory in-system. All bus cycles to or from the flash memory conform to standard microprocessor bus cycles.

#### 3.1 Read

Information can be read from any block, identifier codes or status register independent of the  $V_{PP}$  voltage.  $\overline{RP}$  can be at either  $V_{IH}$  or  $V_{HH}$ .

The first task is to write the appropriate read mode command (Read Array, Read Identifier Codes, or Read Status Register) to the CUI. Upon initial device power-up or after exit from deep power-down mode, the device automatically resets to read array mode. Five control pins dictate the data flow in and out of the component:  $\overline{CE}$ ,  $\overline{OE}$ ,  $\overline{WE}$ ,  $\overline{RP}$  and  $\overline{WP}$ .  $\overline{CE}$  and  $\overline{OE}$  must be driven active to obtain data at the outputs.  $\overline{CE}$  is the device selection control, and when active enables the selected memory device.  $\overline{OE}$  is the data output ( $I/O_0$ - $I/O_{15}$ ) control and when active drives the selected memory data onto the I/O bus.  $\overline{WE}$  must be at  $V_{IH}$  and  $\overline{RP}$  must be at  $V_{IH}$  or  $V_{HH}$ . Figure 10 illustrates a read cycle.

#### 3.2 Output Disable

With  $\overline{OE}$  at a logic-high level ( $V_{IH}$ ), the device outputs are disabled. Output pins ( $I/O_0$ - $I/O_{15}$ ) are placed in a high-impedance state.

#### 3.3 Standby

$\overline{CE}$  at a logic-high level ( $V_{IH}$ ) places the device in standby mode which substantially reduces device power consumption.  $I/O_0$ - $I/O_{15}$  outputs are placed in a high-impedance state independent of  $\overline{OE}$ . If

deselected during block erase or word write, the device continues functioning, and consuming active power until the operation completes.

#### 3.4 Deep Power-Down

$\overline{RP}$  at  $V_{LL}$  initiates the deep power-down mode.

In read modes,  $\overline{RP}$ -low deselects the memory, places output drivers in a high-impedance state and turns off all internal circuits.  $\overline{RP}$  must be held low for a minimum of 100 ns. Time  $t_{PHQV}$  is required after return from power-down until initial memory access outputs are valid. After this wake-up interval, normal operation is restored. The CUI is reset to read array mode and status register is set to 80H.

During block erase or word write modes,  $\overline{RP}$ -low will abort the operation. Memory contents being altered are no longer valid; the data may be partially erased or written. Time  $t_{PHWL}$  is required after  $\overline{RP}$  goes to logic-high ( $V_{IH}$ ) before another command can be written.

As with any automated device, it is important to assert  $\overline{RP}$  during system reset. When the system comes out of reset, it expects to read from the flash memory. Automated flash memories provide status information when accessed during block erase or word write modes. If a CPU reset occurs with no flash memory reset, proper CPU initialization may not occur because the flash memory may be providing status information instead of array data. SHARP's flash memories allow proper CPU initialization following a system reset through the use of the  $\overline{RP}$  input. In this application,  $\overline{RP}$  is controlled by the same  $\overline{RESET}$  signal that resets the system CPU.

### 3.5 Read Identifier Codes Operation

The read identifier codes operation outputs the manufacturer code and device code (see Figure 3). Using the manufacturer and device codes, the system CPU can automatically match the device with its proper algorithms.

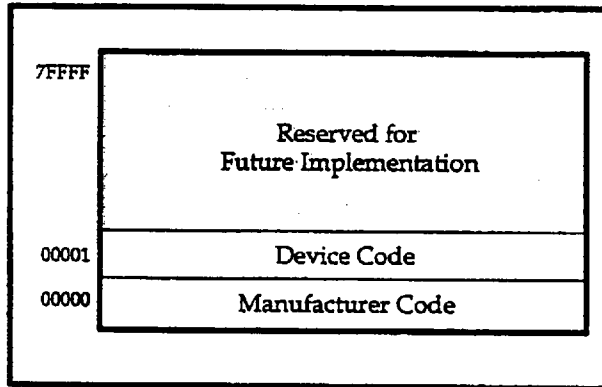

Figure 3. Device Identifier Code Memory Map

### 3.6 Write

Writing commands to the CUI enable reading of device data and identifier codes. They also control inspection and clearing of the status register.

When  $V_{CC}=V_{CC1}$  and  $V_{PP}=V_{PPH}$ , the CUI additionally controls block erasure and word write. The Block Erase command requires appropriate command data and an address within the block to be erased. The Word Write command requires the command and address of the location to be written.

The CUI does not occupy an addressable memory location. It is written when  $\overline{WE}$  and  $\overline{CE}$  are active. The address and data needed to execute a command are latched on the rising edge of  $\overline{WE}$  or  $\overline{CE}$  (whichever goes high first). Standard microprocessor write timings are used. Figures 11 and 12 illustrate  $\overline{WE}$  and  $\overline{CE}$ -controlled write operations.

### 4 COMMAND DEFINITIONS

When  $V_{PP} \leq V_{PPLK}$ , Read operations from the status register, identifier codes or blocks are enabled. Placing  $V_{PPH}$  on  $V_{PP}$  enables successful block erase and word write operations.

Device operations are selected by writing specific commands into the CUI. Table 4 defines these commands.

Table 3. Bus Operations

Mode	Notes	RP	CE	OE	WE	Address	V <sub>PP</sub>	I/O <sub>0-15</sub>
Read	*1,2,7	V <sub>IH</sub> or V <sub>HH</sub>	V <sub>IL</sub>	V <sub>IL</sub>	V <sub>IH</sub>	X	X	D <sub>OUT</sub>
Output Disable		V <sub>IH</sub> or V <sub>HH</sub>	V <sub>IL</sub>	V <sub>IH</sub>	V <sub>IH</sub>	X	X	High Z
Standby		V <sub>IH</sub> or V <sub>HH</sub>	V <sub>IH</sub>	X	X	X	X	High Z
Deep Power-Down	*3	V <sub>IL</sub>	X	X	X	X	X	High Z
Read Identifier Codes		V <sub>IH</sub> or V <sub>HH</sub>	V <sub>IL</sub>	V <sub>IL</sub>	V <sub>IH</sub>	See Figure 3	X	*4
Write	*5,6,7	V <sub>IH</sub> or V <sub>HH</sub>	V <sub>IL</sub>	V <sub>IH</sub>	V <sub>IL</sub>	X	X	D <sub>IN</sub>

#### NOTES:

- \*1 Refer to DC Characteristics. When  $V_{PP} \leq V_{PPLK}$ , memory contents can be read, but not altered.
- \*2 X can be V<sub>IL</sub> or V<sub>IH</sub> for control pins and addresses, and V<sub>PPLK</sub> or V<sub>PPH</sub> for V<sub>PP</sub>. See DC Characteristics for V<sub>PPLK</sub> and V<sub>PPH</sub> voltages.
- \*3 RP at GND±0.2V ensures the lowest deep power-down current.
- \*4 See Section 4.2 for read identifier code data.
- \*5 Command writes involving block erase or word write are reliably executed when  $V_{PP}=V_{PPH}$  and  $V_{CC}=V_{CC1}$ . Block erase or word write with  $V_{IH} < RP < V_{HH}$  produce spurious results and should not be attempted.
- \*6 Refer to Table 4 for valid D<sub>IN</sub> during a write operation.
- \*7 Never hold OE low and WE low at the same timing.

Table 4. Command Definitions<sup>(\*7)</sup>

Command	Bus Cycles Req'd.	Notes	First Bus Cycle			Second Bus Cycle		
			Oper <sup>(*1)</sup>	Addr <sup>(*2)</sup>	Data <sup>(*3)</sup>	Oper <sup>(*1)</sup>	Addr <sup>(*2)</sup>	Data <sup>(*3)</sup>
Read Array/Reset	1		Write	X	FFH			
Read Identifier Codes	≥2	*4	Write	X	90H	Read	IA	ID
Read Status Register	2		Write	X	70H	Read	X	SRD
Clear Status Register	1		Write	X	50H			
Block Erase	2	*5	Write	BA	20H	Write	BA	D0H
Word Write	2	*5,6	Write	WA	40H or 10H	Write	WA	WD
Block Erase and Word Write Suspend	1	*5	Write	X	B0H			
Block Erase and Word Write Resume	1	*5	Write	X	D0H			

NOTES:

- \*1 BUS operations are defined in Table 3.
- \*2 X=Any valid address within the device.  
IA=Identifier Code Address: see Figure 3.  
BA=Address within the block being erased.  
WA=Address of memory location to be written.
- \*3 SRD=Data read from status register. See Table 7 for a description of the status register bits.  
WD=Data to be written at location WA. Data is latched on the rising edge of  $\overline{WE}$  or  $\overline{CE}$  (whichever goes high first).  
ID=Data read from identifier codes.
- \*4 Following the Read Identifier Codes command, read operations access manufacturer and device codes. See Section 4.2 for read identifier code data.
- \*5. When  $\overline{WP}=V_{IL}$ ,  $\overline{RP}$  must beat  $V_{HH}$  to enable block erase or word write operations. Attempts to issue a block erase or word write to a locked boot block while  $\overline{RP}=V_{IH}$ .
- \*6 Either 40H or 10H are recognized by the WSM as the word write setup.
- \*7 Commands other than those shown above are reserved by SHARP for future device implementations and should not be used.



### 4.1 Read Array Command

Upon initial device power-up and after exit from deep power-down mode, the device defaults to read array mode. This operation is also initiated by writing the Read Array command. The device remains enabled for reads until another command is written. Once the internal WSM has started a block erase or word write, the device will not recognize the Read Array command until the WSM completes its operation unless the WSM is suspended via an Erase Suspend or Word Write Suspend command. The Read Array command functions independently of the  $V_{PP}$  voltage and  $\overline{RP}$  can be  $V_{IH}$  or  $V_{HH}$ .

### 4.2 Read Identifier Codes Command

The identifier code operation is initiated by writing the Read Identifier Codes command. Following the command write, read cycles from addresses shown in Figure 3 retrieve the manufacturer and device codes (see Table 5 for identifier code values). To terminate the operation, write another valid command. Like the Read Array command, the Read Identifier Codes command functions independently of the  $V_{PP}$  voltage and  $\overline{RP}$  can be  $V_{IH}$  or  $V_{HH}$ . Following the Read Identifier Codes command, the following information can be read:

Table 5. Identifier Codes

Code	Address	Data
Manufacture Code	00000H	00B0H
Device Code (Top boot)	00001H	0060H

### 4.3 Read Status Register Command

The status register may be read to determine when a block erase or word write is complete and whether the operation completed successfully. It may be read at any time by writing the Read Status Register command. After writing this command, all

subsequent read operations output data from the status register until another valid command is written. The status register contents are latched on the falling edge of  $\overline{OE}$  or  $\overline{CE}$ , whichever occurs.  $\overline{OE}$  or  $\overline{CE}$  must toggle to  $V_{IH}$  before further reads to update the status register latch. The Read Status Register command functions independently of the  $V_{PP}$  voltage.  $\overline{RP}$  can be  $V_{IH}$  or  $V_{HH}$ .

### 4.4 Clear Status Register Command

Status register bits SR.5, SR.4, SR.3 or SR.1 are set to "1"s by the WSM and can only be reset by the Clear Status Register command. These bits indicate various failure conditions (see Table 7). By allowing system software to reset these bits, several operations (such as cumulatively erasing multiple blocks or writing several words in sequence) may be performed. The status register may be polled to determine if an error occurred during the sequence.

To clear the status register, the Clear Status Register command (50H) is written. It functions independently of the applied  $V_{PP}$  Voltage.  $\overline{RP}$  can be  $V_{IH}$  or  $V_{HH}$ . This command is not functional during block erase or word write suspend modes.

### 4.5 Block Erase Command

Erase is executed one block at a time and initiated by a two-cycle command. A block erase setup is first written, followed by a block erase confirm. This command sequence requires appropriate sequencing and an address within the block to be erased (erase changes all block data to FFFFH). Block preconditioning, erase, and verify are handled internally by the WSM (invisible to the system). After the two-cycle block erase sequence is written, the device automatically outputs status register data when read (see Figure 4). The CPU can detect block erase completion by analyzing the output data of the status register bit SR.7.

When the block erase is complete, status register bit SR.5 should be checked. If a block erase error is detected, the status register should be cleared before system software attempts corrective actions. The CUI remains in read status register mode until a new command is issued.

This two-step command sequence of set-up followed by execution ensures that block contents are not accidentally erased. An invalid Block Erase command sequence will result in both status register bits SR.4 and SR.5 being set to "1". Also, reliable block erasure can only occur when  $V_{CC}=V_{CC1}$  and  $V_{PP}=V_{PPH}$ . In the absence of this high voltage, block contents are protected against erasure. If block erase is attempted while  $V_{PP}\leq V_{PPLK}$ , SR.3 and SR.5 will be set to "1". Successful block erase for boot blocks requires that the corresponding if set, that  $\overline{WP}=V_{IH}$  or  $\overline{RP}=V_{HH}$ . If block erase is attempted to boot block when the corresponding  $\overline{WP}=V_{IL}$  or  $\overline{RP}=V_{IH}$ , SR.1 and SR.5 will be set to "1". Block erase operations with  $V_{IH}<\overline{RP}<V_{HH}$  produce spurious results and should not be attempted.

#### 4.6 Word Write Command

Word write is executed by a two-cycle command sequence. Word write setup (standard 40H or alternate 10H) is written, followed by a second write that specifies the address and data (latched on the rising edge of  $\overline{WE}$ ). The WSM then takes over, controlling the word write and write verify algorithms internally. After the word write sequence is written, the device automatically outputs status register data when read (see Figure 5). The CPU can detect the completion of the word write event by analyzing the status register bit SR.7.

When word write is complete, status register bit SR.4 should be checked. If word write error is detected, the status register should be cleared. The internal WSM verify only detects errors for "1"s that do not successfully write to "0"s. The CUI remains in read status register mode until it receives another command.

Reliable word writes can only occur when  $V_{CC}=V_{CC1}$  and  $V_{PP}=V_{PPH}$ . In the absence of this high voltage, memory contents are protected against word writes. If word write is attempted while  $V_{PP}\leq V_{PPLK}$ , status register bits SR.3 and SR.4 will be set to "1".

Successful word write for boot blocks requires that the corresponding if set, that  $\overline{WP}=V_{IH}$  or  $\overline{RP}=V_{HH}$ . If word write is attempted to boot block when the corresponding  $\overline{WP}=V_{IL}$  or  $\overline{RP}=V_{IH}$ , SR.1 and SR.4 will be set to "1". Word write operations with  $V_{IH}<\overline{RP}<V_{HH}$  produce spurious results and should not be attempted.

#### 4.7 Block Erase Suspend Command

The Block Erase Suspend command allows block-erase interruption to read or word-write data in another block of memory. Once the block-erase process starts, writing the Block Erase Suspend command requests that the WSM suspend the block erase sequence at a predetermined point in the algorithm. The device outputs status register data when read after the Block Erase Suspend command is written. Polling status register bits SR.7 and SR.6 can determine when the block erase operation has been suspended (both will be set to "1"). Specification  $t_{WHRH2}$  defines the block erase suspend latency.

At this point, a Read Array command can be written to read data from blocks other than that which is suspended. A Word Write command sequence can also be issued during erase suspend to program data in other blocks. Using the Word Write Suspend command (see Section 4.8), a word write operation can also be suspended. During a word write operation with block erase suspended, status register bit SR.7 will return to "0". However, SR.6 will remain "1" to indicate block erase suspend status.

The only other valid commands while block erase is suspended are Read Status Register and Block Erase Resume. After a Block Erase Resume command is written to the flash memory, the WSM will continue the block erase process. Status register bits SR.6 and SR.7 will automatically clear. After the Erase Resume command is written, the device automatically outputs status register data when read (see Figure 6).  $V_{PP}$  must remain at  $V_{PPH}$  (the same  $V_{PP}$  level used for block erase) while block erase is suspended.  $\overline{RP}$  must also remain at  $V_{IH}$  or  $V_{HH}$  (the same  $\overline{RP}$  level used for block erase).  $\overline{WP}$  must also remain at  $V_{IL}$  or  $V_{IH}$  (the same  $\overline{WP}$  level used for block erase). Block erase cannot resume until word write operations initiated during block erase suspend have completed.

## 4.8 Word Write Suspend Command

The Word Write Suspend command allows word write interruption to read data in other flash memory locations. Once the word write process starts, writing the Word Write Suspend command requests that the WSM suspend the word write sequence at a predetermined point in the algorithm. The device continues to output status register data when read after the Word Write Suspend command is written. Polling status register bits SR.7 and SR.2 can determine when the word write operation has been suspended (both will be set to "1"). Specification  $t_{WHRH1}$  defines the word write suspend latency.

At this point, a Read Array command can be written to read data from locations other than that which is suspended. The only other valid commands while word write is suspended are Read Status Register and Word Write Resume. After Word Write Resume command is written to the flash memory, the WSM will continue the word write process. Status register bits SR.2 and SR.7 will automatically clear. After the Word Write Resume command is written, the device automatically outputs status register data when read (see Figure 7).  $V_{PP}$  must remain at  $V_{PPH}$  (the same  $V_{PP}$  level used for word write) while in word write suspend mode.  $\overline{RP}$  must also remain at  $V_{IH}$  or  $V_{HH}$  (the same  $\overline{RP}$  level used for word write).  $\overline{WP}$  must also remain  $V_{IL}$  or  $V_{IH}$  (the same  $\overline{WP}$  level used for word write).

Table 6. Write Protection Alternatives

Operation	$V_{PP}$	$\overline{RP}$	$\overline{WP}$	Effect
Word Write or Block Erase	$V_{IL}$	X	X	All Blocks Locked.
	$>V_{PPLK}$	$V_{IL}$	X	All Blocks Locked.
		$V_{HH}$	X	All Blocks Unlocked.
		$V_{IH}$	$V_{IL}$	2 Boot Blocks Locked.
			$V_{IH}$	All Blocks Unlocked.

Table 7. Status Register Definition

WSMS	ESS	ES	WWS	VPPS	WWSS	DPS	R
7	6	5	4	3	2	1	0
<p>SR.7 = WRITE STATE MACHINE STATUS(WSMS)                      1 = Ready                      0 = Busy</p> <p>SR.6 = ERASE SUSPEND STATUS(ESS)                      1 = Block Erase Suspended                      0 = Block Erase in Progress/Completed</p> <p>SR.5 = ERASE(ES)                      1 = Error in Block Erasure                      0 = Successful Block Erase</p> <p>SR.4 = WORD WRITE(WWS)                      1 = Error in Word Write                      0 = Successful Word Write</p> <p>SR.3 = <math>V_{pp}</math> STATUS(VPPS)                      1 = <math>V_{pp}</math> Low Detect, Operation Abort                      0 = <math>V_{pp}</math> OK</p> <p>SR.2 = WORD WRITE SUSPEND STATUS(WWSS)                      1 = Word Write Suspended                      0 = Word Write in Progress/Completed</p> <p>SR.1 = DEVICE PROTECT STATUS(DPS)                      1 = <math>\overline{WP}</math> and/or <math>\overline{RP}</math> Lock Detected, Operation Abort                      0 = Unlock</p> <p>SR.0 = RESERVED FOR FUTURE ENHANCEMENTS(R)</p>				<p>NOTES:</p> <p>Check SR.7 to determine block erase or word write completion.                      SR.6-0 are invalid while SR.7="0".</p> <p>If both SR.5 and SR.4 are "1"s after a block erase attempt, an improper command sequence was entered.</p> <p>SR.3 does not provide a continuous indication of <math>V_{pp}</math> level. The WSM interrogates and indicates the <math>V_{pp}</math> level only after Block Erase or Word Write command sequences. SR.3 is not guaranteed to reports accurate feedback only when <math>V_{pp} \neq V_{ppH}</math>.</p> <p>The WSM interrogates the <math>\overline{WP}</math> and <math>\overline{RP}</math> only after Block Erase or Word Write command sequences. If informs the system, depending on the attempted operation, if the <math>\overline{WP}</math> is not <math>V_{IH}</math> or <math>\overline{RP}</math> is not <math>V_{IH}</math>.</p> <p>SR.0 is reserved for future use and should be masked out when polling the status register.</p>			

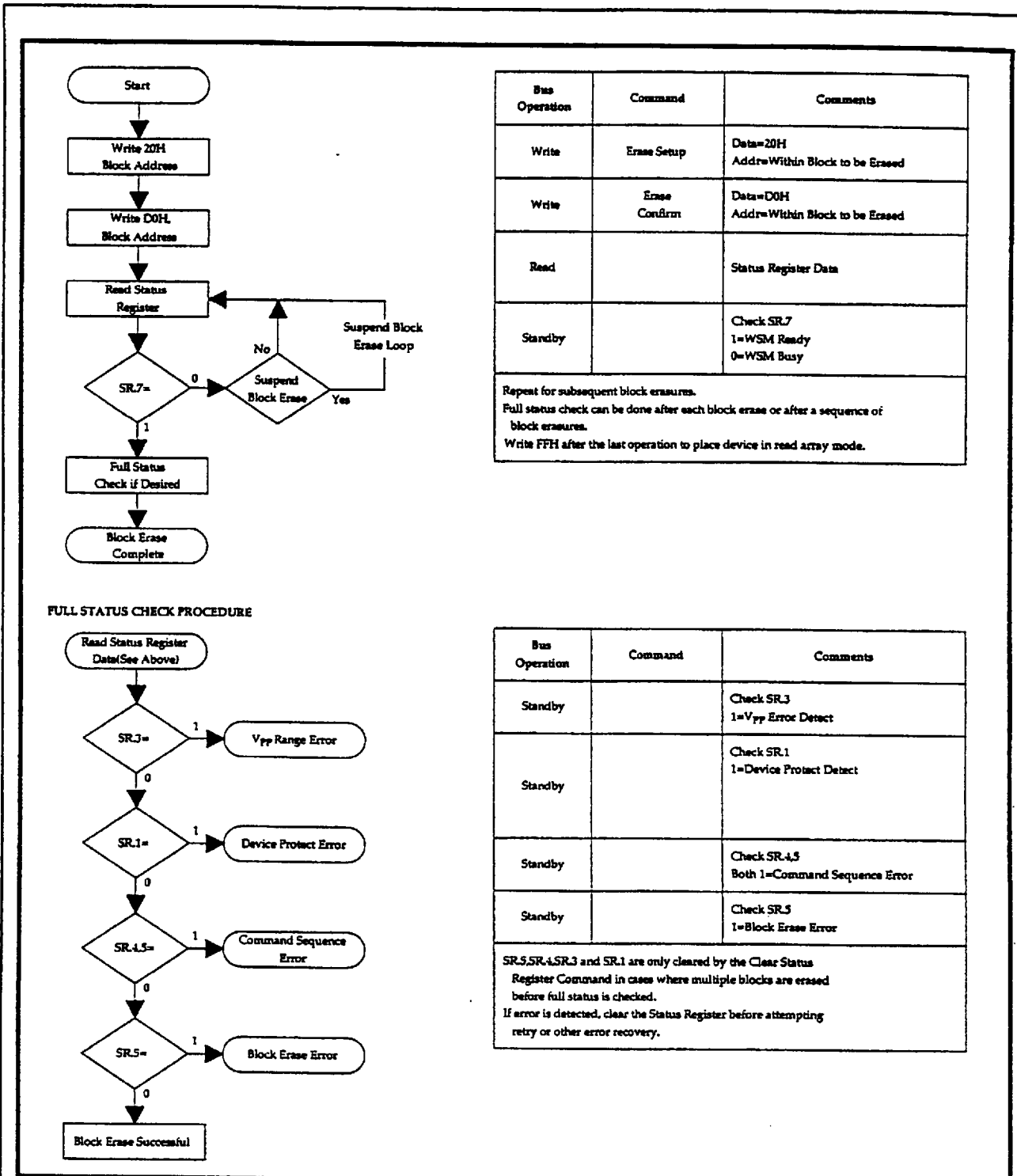

Figure4. Automated Block Erase Flowchart

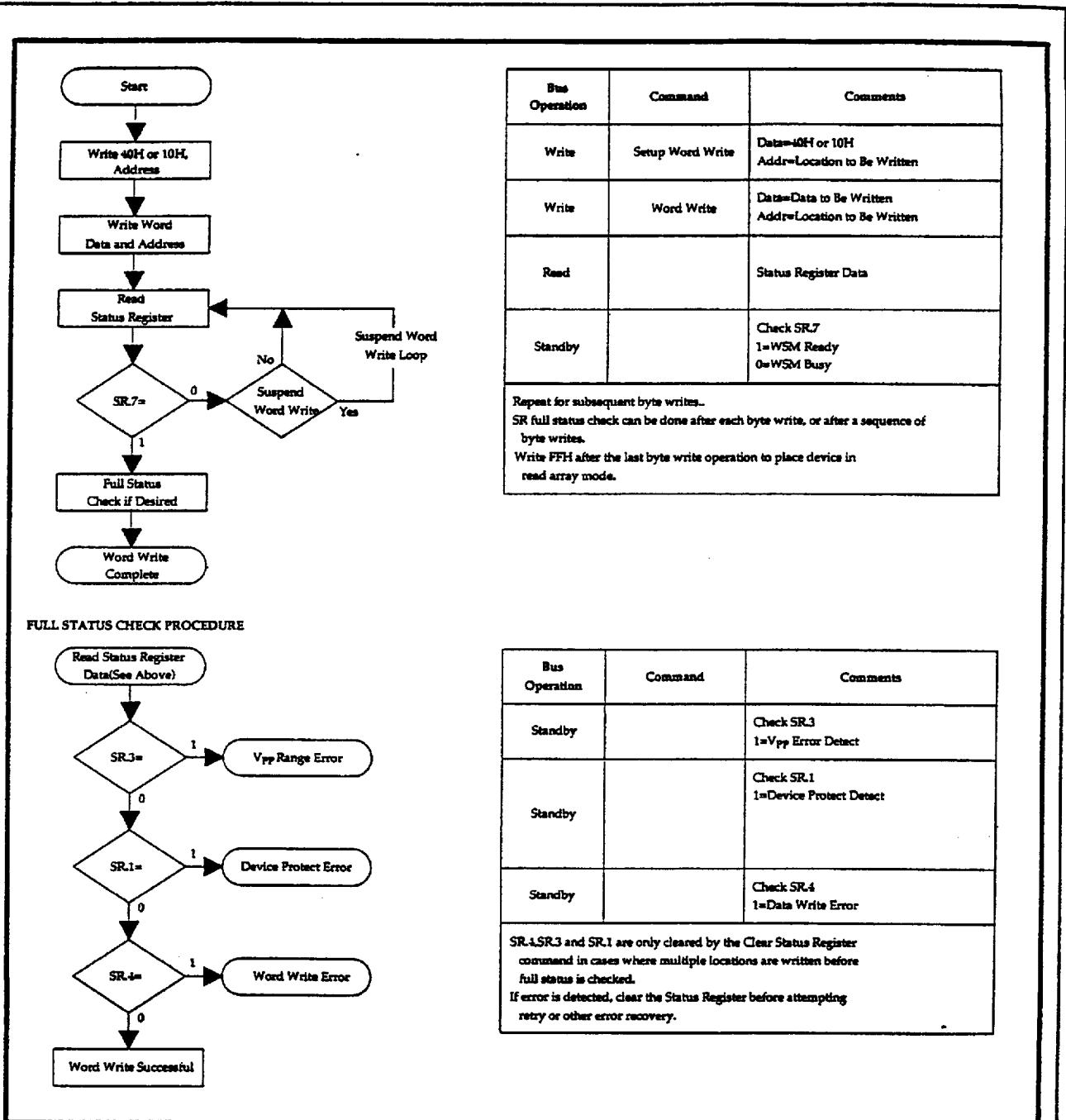

Figure5. Automated Word Write Flowchart

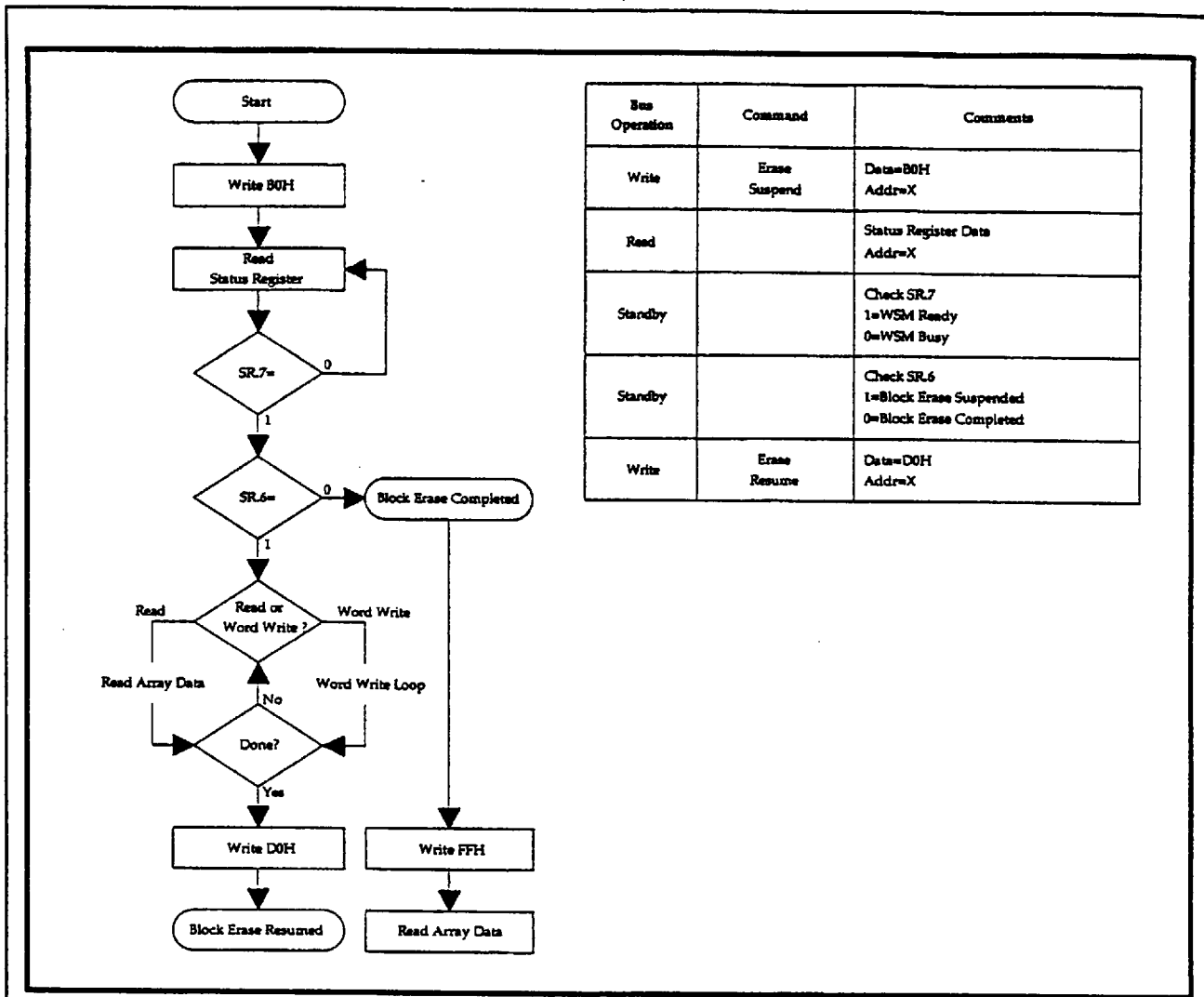
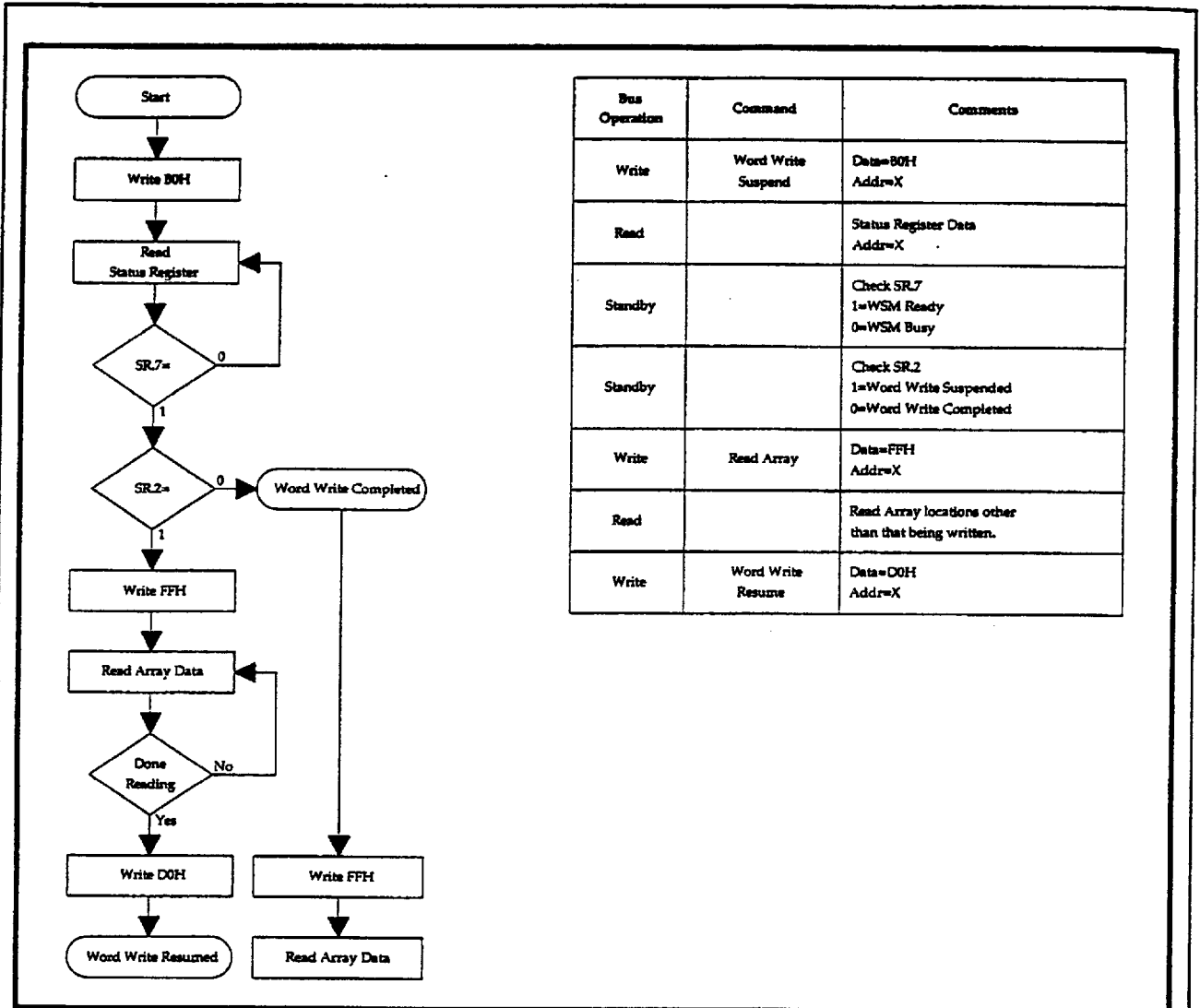

Figure6. Block Erase Suspend/Resume Flowchart



Bus Operation	Command	Comments
Write	Word Write Suspend	Data=80H Addr=X
Read		Status Register Data Addr=X
Standby		Check SR.7 1=WSM Ready 0=WSM Busy
Standby		Check SR.2 1=Word Write Suspended 0=Word Write Completed
Write	Read Array	Data=FFH Addr=X
Read		Read Array locations other than that being written.
Write	Word Write Resume	Data=D0H Addr=X

Figure7. Word Write Suspend/Resume Flowchart



## 5 DESIGN CONSIDERATIONS

### 5.1 Three-Line Output Control

The device will often be used in large memory arrays. SHARP provides three control inputs to accommodate multiple memory connections. Three-line control provides for:

- a. Lowest possible memory power dissipation.
- b. Complete assurance that data bus contention will not occur.

To use these control inputs efficiently, an address decoder should enable  $\overline{CE}$  while  $\overline{OE}$  should be connected to all memory devices and the system's  $\overline{READ}$  control line. This assures that only selected memory devices have active outputs while deselected memory devices are in standby mode.  $\overline{RP}$  should be connected to the system POWERGOOD signal to prevent unintended writes during system power transitions. POWERGOOD should also toggle during system reset.

### 5.2 Power Supply Decoupling

Flash memory power switching characteristics require careful device decoupling. System designers are interested in three supply current issues; standby

current levels, active current levels and transient peaks produced by falling and rising edges of  $\overline{CE}$  and  $\overline{OE}$ . Transient current magnitudes depend on the device outputs' capacitive and inductive loading. Two-line control and proper decoupling capacitor selection will suppress transient voltage peaks. Each device should have a 0.1  $\mu\text{F}$  ceramic capacitor connected between its  $V_{CC}$  and GND and between its  $V_{PP}$  and GND. These high-frequency, low inductance capacitors should be placed as close as possible to package leads. Additionally, for every eight devices, a 4.7  $\mu\text{F}$  electrolytic capacitor should be placed at the array's power supply connection between  $V_{CC}$  and GND. The bulk capacitor will overcome voltage slumps caused by PC board trace inductance.

### 5.3 $V_{PP}$ Trace on Printed Circuit Boards

Updating flash memories that reside in the target system requires that the printed circuit board designer pay attention to the  $V_{PP}$  Power supply trace. The  $V_{PP}$  pin supplies the memory cell current for word writing and block erasing. Use similar trace widths and layout considerations given to the  $V_{CC}$  power bus. Adequate  $V_{PP}$  supply traces and decoupling will decrease  $V_{PP}$  voltage spikes and overshoots.

#### 5.4 $V_{CC}$ , $V_{PP}$ , $\overline{RP}$ Transitions

Block erase and word write are not guaranteed if  $V_{PP}$  falls outside of a valid  $V_{PPH}$  range,  $V_{CC}$  falls outside of a valid  $V_{CC2}$  range, or  $\overline{RP} \neq V_{IH}$  or  $V_{HH}$ . If  $V_{PP}$  error is detected, status register bit SR.3 is set to "1" along with SR.4 or SR.5, depending on the attempted operation. If  $\overline{RP}$  transitions to  $V_{IL}$  during block erase or word write, the operation will abort and the device will enter deep power-down. The aborted operation may leave data partially altered. Therefore, the command sequence must be repeated after normal operation is restored. Device power-off or  $\overline{RP}$  transitions to  $V_{IL}$  clear the status register.

The CUI latches commands issued by system software and is not altered by  $V_{pp}$  or  $\overline{CE}$  transitions or WSM actions. Its state is read array mode upon power-up, after exit from deep power-down or after  $V_{CC}$  transitions below  $V_{LKO}$ .

After block erase or word write, even after  $V_{pp}$  transitions down to  $V_{PPLK}$ , the CUI must be placed in read array mode via the Read Array command if subsequent access to the memory array is desired.

#### 5.5 Power-Up/Down Protection

The device is designed to offer protection against accidental block erasure or word writing during power transitions. Upon power-up, the device is indifferent as to which power supply ( $V_{PP}$  or  $V_{CC}$ ) powers-up first. Internal circuitry resets the CUI to read array mode at power-up.

A system designer must guard against spurious writes for  $V_{CC}$  voltages above  $V_{LKO}$  when  $V_{PP}$  is active. Since both  $\overline{WE}$  and  $\overline{CE}$  must be low for a command write, driving either to  $V_{HH}$  will inhibit writes. The CIU's two-step command sequence architecture provides added level of protection against data alteration.

$\overline{WP}$  provide additional protection from inadvertent code or data alteration.

The device is disabled while  $\overline{RP} = V_{IL}$  regardless of its control inputs state.

#### 5.6 Power Dissipation

When designing portable systems, designers must consider battery power consumption not only during device operation, but also for data retention during system idle time. Flash memory's nonvolatility increases usable battery life because data is retained when system power is removed.

In addition, deep power-down mode ensures extremely low power consumption even when system power is applied. For example, portable computing products and other power sensitive applications that use an array of devices for solid-state storage can consume negligible power by lowering  $\overline{RP}$  to  $V_{IL}$  standby or sleep modes. If access is again needed, the devices can be read following the  $t_{PHQV}$  and  $t_{PHWL}$  wake-up cycles required after  $\overline{RP}$  is first raised to  $V_{IH}$ . See AC Characteristics—Read Only and Write Operations and Figures 12, 13 and 14 for more information.

## 6 ELECTRICAL SPECIFICATIONS

### 6.1 Absolute Maximum Ratings\*

Commercial Operating Temperature	
During Read, Block Erase and	
Word Write .....	-40°C to +85°C <sup>(1)</sup>
Temperature under Bias.....	-40°C to +85°C
Storage Temperature .....	-65°C to +125°C
Voltage On Any Pin	
except $V_{CC}$ , $V_{PP}$ , and $\overline{RP}$ .....	-2.0V to +7.0V <sup>(2)</sup>
$V_{CC}$ Supply Voltage.....	-2.0V to +7.0V <sup>(2)</sup>
$V_{PP}$ Update Voltage during	
Block Erase and Word Write ...	-2.0V to +14.0V <sup>(2,3)</sup>
$\overline{RP}$ Voltage.....	-2.0V to +14.0V <sup>(2,3)</sup>
Output Short Circuit Current .....	100mA <sup>(4)</sup>

\*WARNING: Stressing the device beyond the "Absolute Maximum Ratings" may cause permanent damage. These are stress ratings only. Operation beyond the "Operating Conditions" is not recommended and extended exposure beyond the "Operating Conditions" may affect device reliability.

#### NOTES:

- \*1 Operating temperature is for commercial product defined by this specification.
- \*2 All specified voltages are with respect to GND. Minimum DC voltage is -0.5V on input/output pins and -0.2V on  $V_{CC}$  and  $V_{PP}$  pins. During transitions, this level may undershoot to -2.0V for periods <20ns. Maximum DC voltage on input/output pins and  $V_{CC}$  is  $V_{CC}+0.5V$  which, during transitions, may overshoot to  $V_{CC}+2.0V$  for periods <20ns.
- \*3 Maximum DC voltage on  $V_{PP}$  and  $\overline{RP}$  may overshoot to +14.0V for periods <20ns.
- \*4 Output shorted for no more than one second. No more than one output shorted at a time.

## 6.2 Operating Conditions

### Temperature and $V_{CC}$ Operating Conditions

Symbol	Parameter	Notes	Min	Max	Unit	Test Condition
$T_A$	Operating Temperature		-40	+85	°C	Ambient Temperature
$V_{CCI}$	$V_{CC}$ Supply Voltage (2.7V-3.6V)		2.7	3.6	V	

### 6.2.1 AC INPUT/OUTPUT TEST CONDITIONS

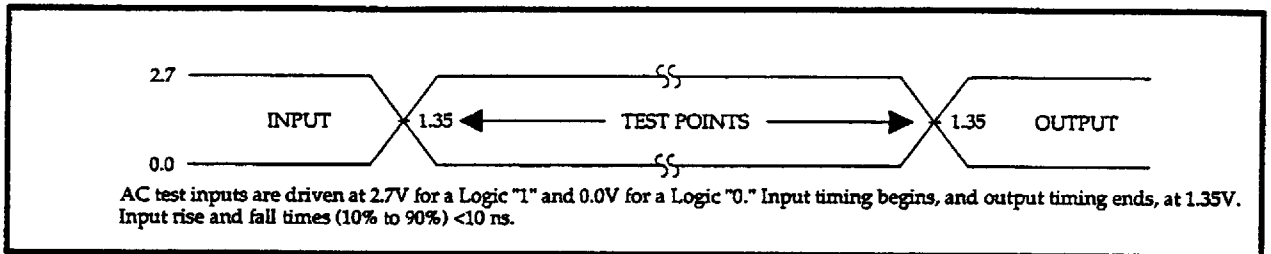

Figure8. Transient Input/Output Reference Waveform for  $V_{CC}=2.7V-3.6V$

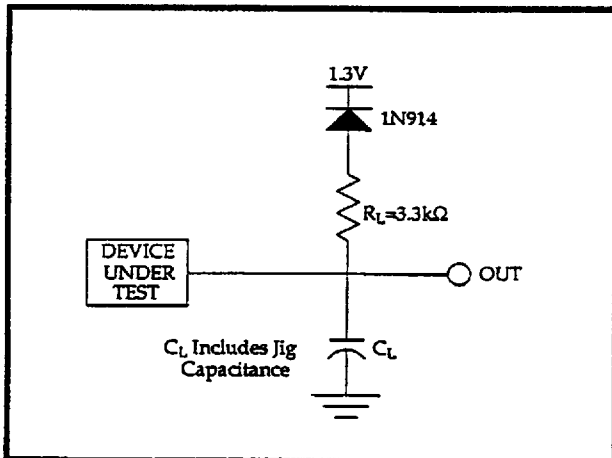

Figure9. Transient Equivalent Testing Load Circuit

### Test Configuration Capacitance Loading Value

Test Configuration	$C_L$ (pF)
$V_{CC}=2.7V-3.6V$	50

## 6.2.2 DC CHARACTERISTICS

DC Characteristics

Sym	Parameter	Notes	V <sub>CC</sub> =2.7V-3.6V		Unit	Test Conditions
			Typ	Max		
I <sub>LI</sub>	Input Load Current	*1		±0.5	μA	V <sub>CC</sub> =V <sub>CC</sub> Max V <sub>IN</sub> =V <sub>CC</sub> or GND
I <sub>LO</sub>	Output Leakage Current	*1		±0.5	μA	V <sub>CC</sub> =V <sub>CC</sub> Max V <sub>OUT</sub> =V <sub>CC</sub> or GND
I <sub>CCS</sub>	V <sub>CC</sub> Standby Current	*1 *5	25	50	μA	CMOS Inputs V <sub>CC</sub> =V <sub>CC</sub> Max CE=RP=V <sub>CC</sub> ±0.2V
			0.2	2	mA	TTL Inputs V <sub>CC</sub> =V <sub>CC</sub> Max CE=RP=V <sub>IH</sub>
I <sub>CCD</sub>	V <sub>CC</sub> Deep Power-Down Current	*1	4	20	μA	RP=GND±0.2V
I <sub>CCR</sub>	V <sub>CC</sub> Read Current	*1,4 *5	15	25	mA	CMOS Inputs V <sub>CC</sub> =V <sub>CC</sub> Max, CE=GND f=5MHz(2.7V-3.6V), I <sub>OUT</sub> =0mA
				30	mA	TTL Inputs V <sub>CC</sub> =V <sub>CC</sub> Max, CE=GND f=5MHz(2.7V-3.6V), I <sub>OUT</sub> =0mA
I <sub>CCW</sub>	V <sub>CC</sub> Word Write Current	*1,6	5	17	mA	V <sub>PP</sub> =V <sub>PPH</sub>
I <sub>CCE</sub>	V <sub>CC</sub> Block Erase Current	*1,6	4	17	mA	V <sub>PP</sub> =V <sub>PPH</sub>
I <sub>CCWS</sub> I <sub>CCES</sub>	V <sub>CC</sub> Word Write or Block Erase Suspend Current	*1,2	1	6	mA	CE=V <sub>IH</sub>
I <sub>PPS</sub> I <sub>PPR</sub>	V <sub>PP</sub> Standby or Read Current	*1	±2	±15	μA	V <sub>PP</sub> ≤V <sub>CC</sub>
			10	200	μA	V <sub>PP</sub> >V <sub>CC</sub>
I <sub>PPD</sub>	V <sub>PP</sub> Deep Power-Down Current	*1	0.1	5	μA	RP=GND±0.2V
I <sub>PPW</sub>	V <sub>PP</sub> Word Write Current	*1,6	12	40	mA	V <sub>PP</sub> =V <sub>PPH</sub>
I <sub>PPE</sub>	V <sub>PP</sub> Block Erase Current	*1,6	8	25	mA	V <sub>PP</sub> =V <sub>PPH</sub>
I <sub>PPWS</sub> I <sub>PPES</sub>	V <sub>PP</sub> Word Write or Block Erase Suspend Current	*1	10	200	μA	V <sub>PP</sub> =V <sub>PPH</sub>

DC Characteristics (Continued)

Sym	Parameter	Notes	V <sub>CC</sub> =2.7V-3.6V		Unit	Test Conditions
			Min	Max		
V <sub>IL</sub>	Input Low Voltage	*6	-0.5	0.8	V	
V <sub>IH</sub>	Input High Voltage	*6	2.0	V <sub>CC</sub> +0.5	V	
V <sub>OL</sub>	Output Low Voltage	*6		0.4	V	V <sub>CC</sub> =V <sub>CC</sub> Min, I <sub>OL</sub> =2.0mA(3.3V)
V <sub>OH1</sub>	Output High Voltage (TTL)	*6	2.4		V	V <sub>CC</sub> =V <sub>CC</sub> Min, I <sub>OH</sub> =-2.0mA(3.3V)
V <sub>OH2</sub>	Output High Voltage (CMOS)	*6	0.85		V	V <sub>CC</sub> =V <sub>CC</sub> Min I <sub>OH</sub> =-2.5mA
			V <sub>CC</sub> -0.4		V	V <sub>CC</sub> =V <sub>CC</sub> Min I <sub>OH</sub> =-100μA
V <sub>PPLK</sub>	V <sub>PP</sub> Lockout during Normal Operations	*3,6		1.5	V	
V <sub>PPH</sub>	V <sub>PP</sub> during Word Write or Block Erase Operations		2.7	3.6	V	
V <sub>LKO</sub>	V <sub>CC</sub> Lockout Voltage		2.0		V	
V <sub>HH</sub>	RP Unlock Voltage	*7,8	11.4	12.6	V	Unable WP

NOTES:

- \*1 All currents are in RMS unless otherwise noted.
- \*2 I<sub>CCWS</sub> and I<sub>CCES</sub> are specified with the device de-selected. If read or word written while in erase suspend mode, the device's current draw is the sum of I<sub>CCWS</sub> or I<sub>CCES</sub> and I<sub>CCR</sub> or I<sub>CCW</sub>, respectively.
- \*3 Block erases and word writes are inhibited when V<sub>PP</sub> ≤ V<sub>PPLK</sub>, and not guaranteed in the range between V<sub>PPLK</sub>(max) and V<sub>PPH</sub>(min).
- \*4 Automatic Power Savings (APS) reduces typical I<sub>CCR</sub> to 3mA at 3.3V V<sub>CC</sub> in static operation.
- \*5 CMOS inputs are either V<sub>CC</sub>±0.2V or GND±0.2V. TTL inputs are either V<sub>IL</sub> or V<sub>IH</sub>.
- \*6 Sampled, not 100% tested.
- \*7 Block erases and word writes are inhibited when the corresponding  $\overline{RP}=V_{IH}$  or  $\overline{WP}=V_{IL}$ . Block erase and word write operations are not guaranteed with V<sub>IH</sub> <  $\overline{RP}$  < V<sub>HH</sub> and should not be attempted.
- \*8 RP connection to a V<sub>HH</sub> supply is allowed for a maximum cumulative period of 80 hours.

## 6.2.3 AC Characteristics - Read-Only Operations<sup>(\*)</sup>

$V_{CC}=2.7V-3.6V, T_a=-40^{\circ}C$  to  $+85^{\circ}C$

Sym	Parameter	Notes	Min	Max	Unit
$t_{AVAV}$	Read Cycle Time		120		ns
$t_{AVOV}$	Address to Output Delay			120	ns
$t_{ELQV}$	$\overline{CE}$ to Output Delay	*2		120	ns
$t_{PHOV}$	$\overline{RF}$ High to Output Delay			600	ns
$t_{GLOV}$	$\overline{OE}$ to Output Delay	*2		50	ns
$t_{ELOX}$	$\overline{CE}$ to Output in Low Z	*3	0		ns
$t_{EHOZ}$	$\overline{CE}$ High to Output in High Z	*3		55	ns
$t_{GLOX}$	$\overline{OE}$ to Output in Low Z	*3	0		ns
$t_{GHOZ}$	$\overline{OE}$ High to Output in High Z	*3		20	ns
$t_{OH}$	Output Hold from Address, $\overline{CE}$ or $\overline{OE}$ Change, Whichever Occurs First	*3	0		ns

### NOTES:

- \*1 See AC Input/Output Reference Waveform for maximum allowable input slew rate.
- \*2  $\overline{OE}$  may be delayed up to  $t_{ELQV}-t_{GLOV}$  after the falling edge of  $\overline{CE}$  without impact on  $t_{ELQV}$ .
- \*3 Sampled, not 100% tested.

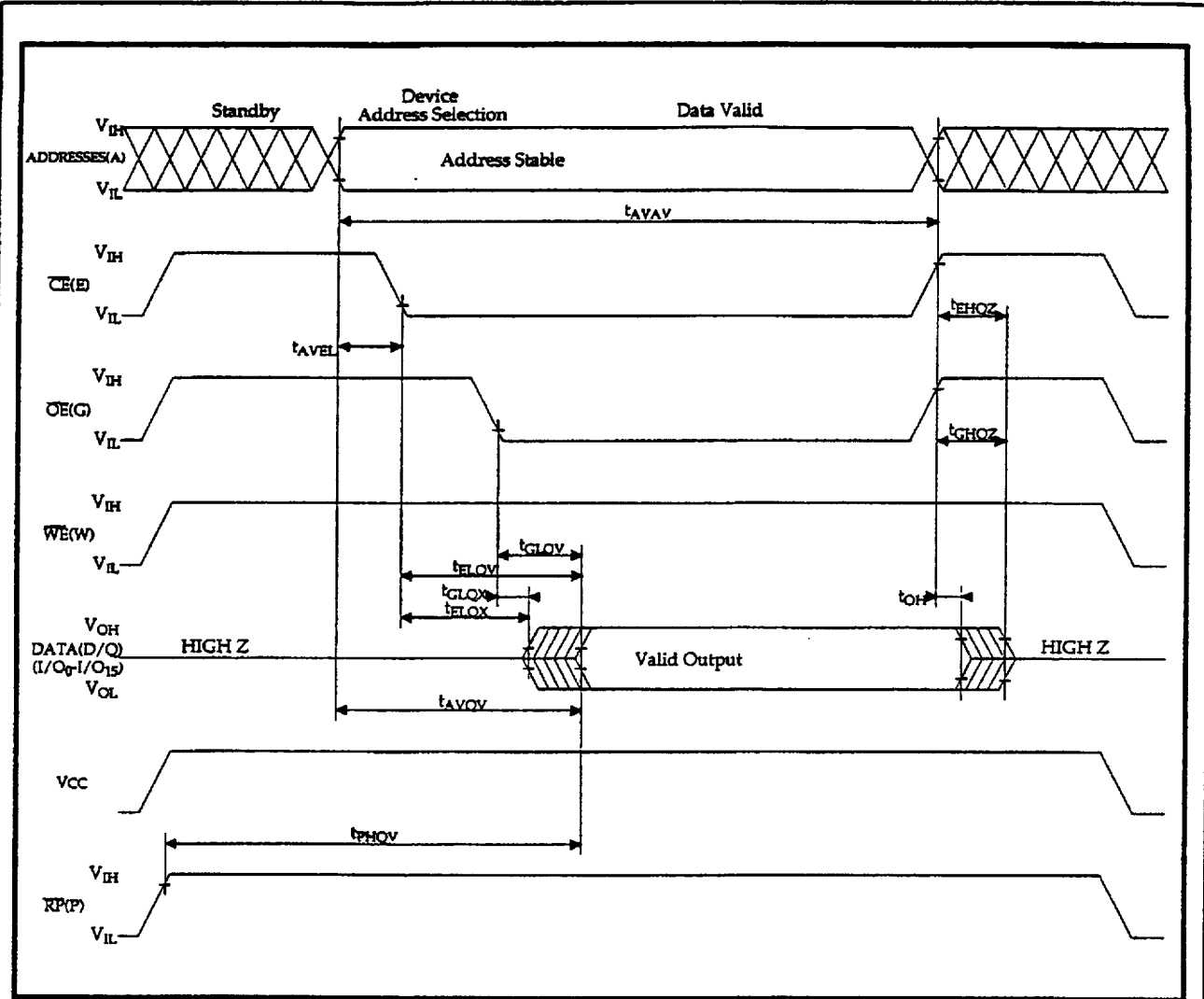

Figure10. AC Waveform for Read Operations



## 6.2.4 AC Characteristics - Write Operations(\*1)

$V_{CC}=2.7V-3.6V$ ,  $T_a=-40^{\circ}C$  to  $+85^{\circ}C$

Sym	Parameter	Notes	Min	Max	Unit
$t_{AVAV}$	Write Cycle Time		120		ns
$t_{PHWL}$	$\overline{RP}$ High Recovery to $\overline{WE}$ Going Low	*2	1		$\mu s$
$t_{ELWL}$	$\overline{CE}$ Setup to $\overline{WE}$ Going Low		10		ns
$t_{WLWH}$	$\overline{WE}$ Pulse Width		50		ns
$t_{PHHWH}$	$\overline{RP} V_{HH}$ to $\overline{WE}$ Going High	*2	100		ns
$t_{SHWH}$	$\overline{WP} V_{IH}$ Setup to $\overline{WE}$ Going High	*2	100		ns
$t_{VPWH}$	$V_{pp}$ Setup to $\overline{WE}$ Going High	*2	100		ns
$t_{AVWH}$	Address Setup to $\overline{WE}$ Going High	*3	50		ns
$t_{DVWH}$	Data Setup to $\overline{WE}$ Going High	*3	50		ns
$t_{WHDX}$	Data Hold from $\overline{WE}$ High		5		ns
$t_{WHAX}$	Address Hold from $\overline{WE}$ High		5		ns
$t_{WHEH}$	$\overline{CE}$ Hold from $\overline{WE}$ High		10		ns
$t_{WHWL}$	$\overline{WE}$ Pulse Width High		30		ns
$t_{WHGL}$	Write Recovery before Read		0		ns
$t_{QVVL}$	$V_{pp}$ Hold from Valid SRD High	*2	0		ns
$t_{QVPH}$	$\overline{RP} V_{HH}$ Hold from Valid SRD High	*2	0		ns
$t_{QVSL}$	$\overline{WP} V_{IH}$ Hold from Valid SRD High	*2	0		ns

### NOTES:

- \*1 Read timing characteristics during block erase and word write operations are the same as during read-only operations. Refer to AC Characteristics for read-only operations.
- \*2 Sampled, not 100% tested.
- \*3 Refer to Table 4 for valid  $A_{IN}$  and  $D_{IN}$  for block erase or word write.
- \*4  $V_{pp}$  should be held at  $V_{ppH}$  (and if necessary  $\overline{RP}$  should be held at  $V_{HH}$ ) until determination of block erase or word write success (SR.1/3/4/5=0).

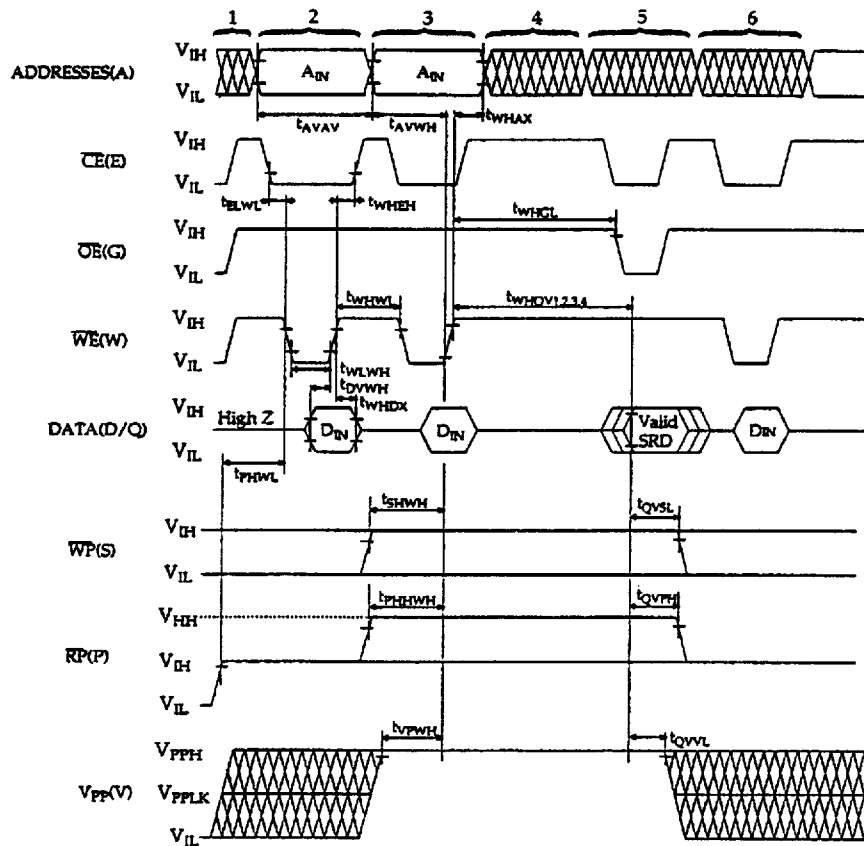

**NOTES:**

1. VCC power-up and standby.
2. Write block erase or word write setup.
3. Write block erase confirm or valid address and data.
4. Automated erase or program delay.
5. Read status register data.
6. Write Read Array command.

Figure 11. AC Waveform for WE-Controlled Write Operations

## 6.2.5 Alternative $\overline{CE}$ -Controlled Writes (\*1)

$V_{CC}=2.7V-3.6V, T_a=-40^{\circ}C$  to  $+85^{\circ}C$

Sym	Parameter	Notes	Min	Max	Unit
$t_{AVAV}$	Write Cycle Time		120		ns
$t_{PHEL}$	$\overline{RP}$ High Recovery to $\overline{CE}$ Going Low	*2	1		$\mu s$
$t_{WLEL}$	$\overline{WE}$ Setup to $\overline{CE}$ Going Low		0		ns
$t_{ELEH}$	$\overline{CE}$ Pulse Width		70		ns
$t_{PHIEH}$	$\overline{RP} V_{HH}$ Setup to $\overline{CE}$ Going High	*2	100		ns
$t_{SHEH}$	$\overline{WP} V_{IH}$ Setup to $\overline{CE}$ Going High	*2	100		ns
$t_{VPEH}$	$V_{pp}$ Setup to $\overline{CE}$ Going High	*2	100		ns
$t_{AVEH}$	Address Setup to $\overline{CE}$ Going High	*3	50		ns
$t_{DVEH}$	Data Setup to $\overline{CE}$ Going High	*3	50		ns
$t_{EHDX}$	Data Hold from $\overline{CE}$ High		5		ns
$t_{EHAX}$	Address Hold from $\overline{CE}$ High		5		ns
$t_{EHWL}$	$\overline{WE}$ Hold from $\overline{CE}$ High		0		ns
$t_{EHEL}$	$\overline{CE}$ Pulse Width High		25		ns
$t_{EHGL}$	Write Recovery before Read		0		ns
$t_{QVVL}$	$V_{pp}$ Hold from Valid SRD High	*2	0		ns
$t_{QVPH}$	$\overline{RP} V_{HH}$ Hold from Valid SRD High	*2	0		ns
$t_{QVSL}$	$\overline{WP} V_{IH}$ Hold from Valid SRD High	*2	0		ns

### NOTES:

- \*1 In systems where  $\overline{CE}$  defines the write pulse width (within a longer  $\overline{WE}$  timing waveform), all setup, hold, and inactive  $\overline{WE}$  times should be measured relative to the  $\overline{CE}$  waveform.
- \*2 Sampled, not 100% tested.
- \*3 Refer to Table 4 for valid  $A_{IN}$  and  $D_{IN}$  for block erase or word write.
- \*4  $V_{pp}$  should be held at  $V_{ppH}$  (and if necessary  $\overline{RP}$  should be held at  $V_{HH}$ ) until determination of block erase or word write success (SR.1/3/4/5=0).

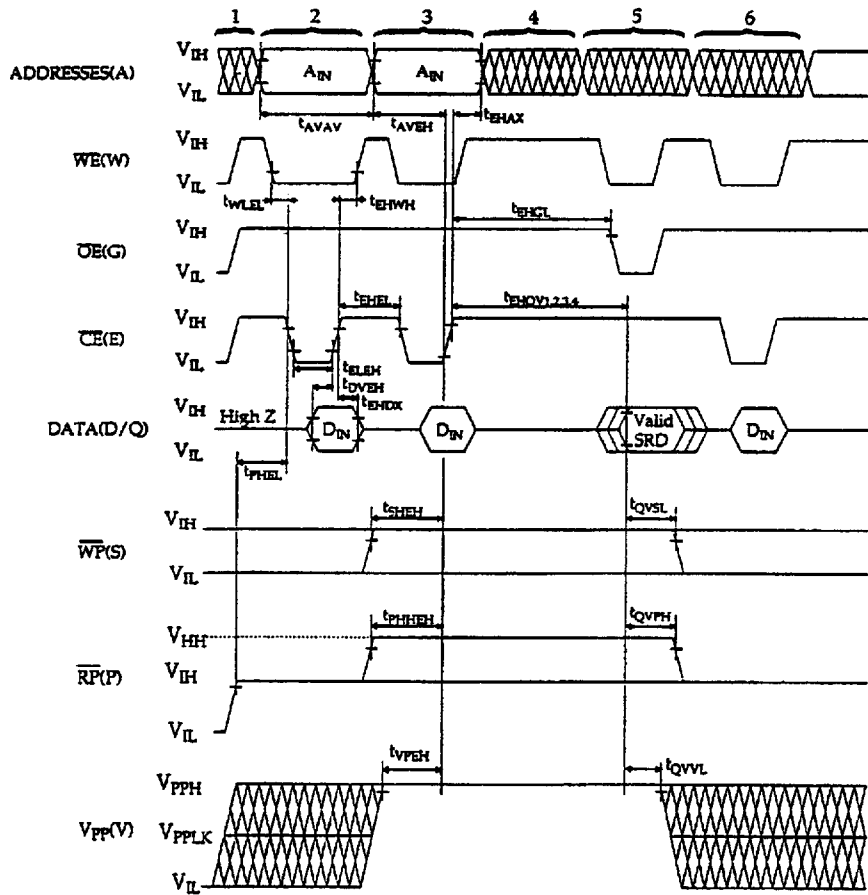

- NOTES:
1. V<sub>CC</sub> power-up and standby.
  2. Write block erase or word write setup.
  3. Write block erase confirm or valid address and data.
  4. Automated erase or program delay.
  5. Read status register data.
  6. Write Read Array command.

Figure12. Alternate AC Waveform for  $\overline{CE}$ -Controlled Write Operations

## 6.2.6 Reset Operations

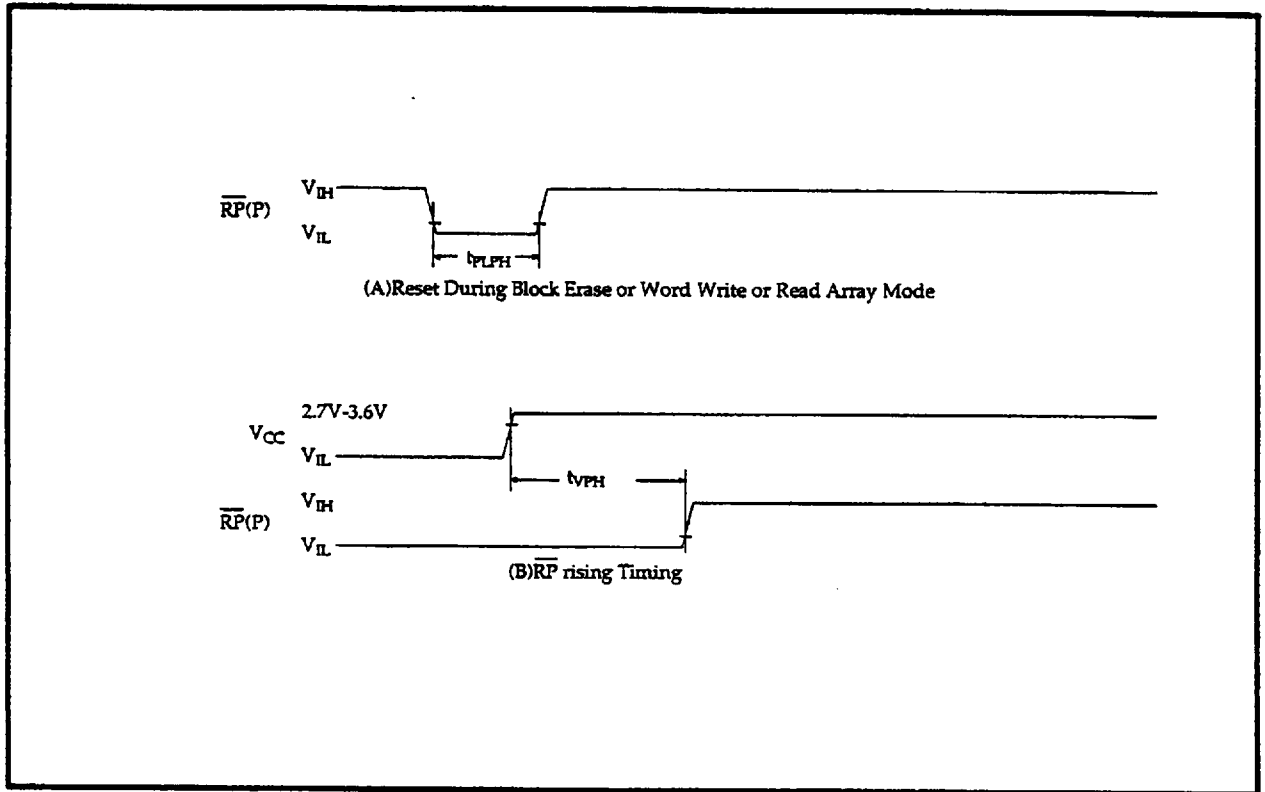

Figure13. AC Waveform for Reset Operation

Reset AC Specifications<sup>(\*1)</sup>

Sym	Parameter	Notes	$V_{CC}=2.7V$ to $3.6V$		Unit
			Min	Max	
$t_{PLPH}$	$\overline{RP}$ Pulse Low Time (If $\overline{RP}$ is tied to $V_{CC}$ , this specification is not applicable)		100		ns
$t_{VPH}$	$V_{CC}$ 2.7V to $\overline{RP}$ High	*2	100		ns

NOTES:

\*1 These specifications are valid for all product versions (packages and speeds).

\*2 When the device power-up, holding  $\overline{RP}$  low minimum 100ns is required after  $V_{CC}$  has been in predefined range and also has been in stable there.

## 6.2.7 Block Erase and Word Write Performance(\*3)

$V_{CC}=2.7V-3.6V$ ,  $T_a=-40^{\circ}C$  to  $+85^{\circ}C$

Sym	Parameter		Notes	$V_{PP}=2.7V-3.6V$			Unit
				Min	Typ (*)	Max	
$t_{WHQV1}$	Word Write Time	32K word block	*2		44.6		$\mu s$
$t_{EHQV1}$		4K word block	*2		45.9		
	Block Write Time	32K word block	*2		1.46		sec
		4K word block	*2		0.19		
$t_{WHQV2}$	Block Erase Time	32K word block	*2		1.14		sec
$t_{EHQV2}$		4K word block	*2		0.38		
$t_{WHRH1}$	Word Write Suspend Latency Time to Read				7	8	$\mu s$
$t_{EHRH2}$	Erase Suspend Latency Time to Read				18	22	$\mu s$

### NOTES:

- \*1 Typical values measured at  $T_a=+25^{\circ}C$  and nominal voltages. Subject to change based on device characterization.
- \*2 Excludes system-level overhead.
- \*3 Sampled but not 100% tested.

Part 3 SRAM  
CONTENTS

1. Description .....	40
2. Truth Table .....	41
3. Block Diagram .....	41
4. Absolute Maximum Ratings .....	42
5. Recommended DC Operating Conditions .....	42
6. DC Electrical Characteristics .....	42
7. AC Electrical Characteristics .....	43
8. Timing Chart .....	44

### 1. Description

The LRS1306 is a 2M bit static RAM organized as 262,144×8 bit which provides low-power standby mode.

It is fabricated using silicon-gate CMOS process technology.

### Features

Access Time .....	85 ns(Max.)
Operating current .....	35 mA(Max.)
	25 mA(Max. $t_{CYCLE}=200ns$ )
Standby current .....	120 $\mu A$ (Max.)
	1.0 $\mu A$ (Typ. $V_{CCDR}=3V, T_a=25^{\circ}C$ )
Single power supply .....	2.7V to 3.6V
Operating temperature .....	-40 $^{\circ}C$ to +85 $^{\circ}C$
Fully static operation	
Three-state output	
Not designed or rated as radiation hardened	
N-type bulk silicon	



2. Truth Table ( $\overline{CE}$ ,  $\overline{OE}$  and  $\overline{WE}$  mean S- $\overline{CE}$ , S- $\overline{OE}$  and S- $\overline{WE}$  respectively.)

$\overline{CE}$	$\overline{WE}$	$\overline{OE}$	Mode	I/O <sub>0</sub> to I/O <sub>7</sub>	Supply current
H	X	X	Standby	High impedance	Standby(I <sub>SB</sub> )
L	L	X	Write	Data input	Active(I <sub>CC</sub> )
L	H	L	Read	Data output	Active(I <sub>CC</sub> )
L	H	H	Output disable	High impedance	Active(I <sub>CC</sub> )

(X=Don't Care, L=Low, H=High)

3. Block Diagram (V<sub>CC</sub> means S-V<sub>CC</sub>. A<sub>n</sub> means S-A<sub>n</sub>, where n=0 to 17.)

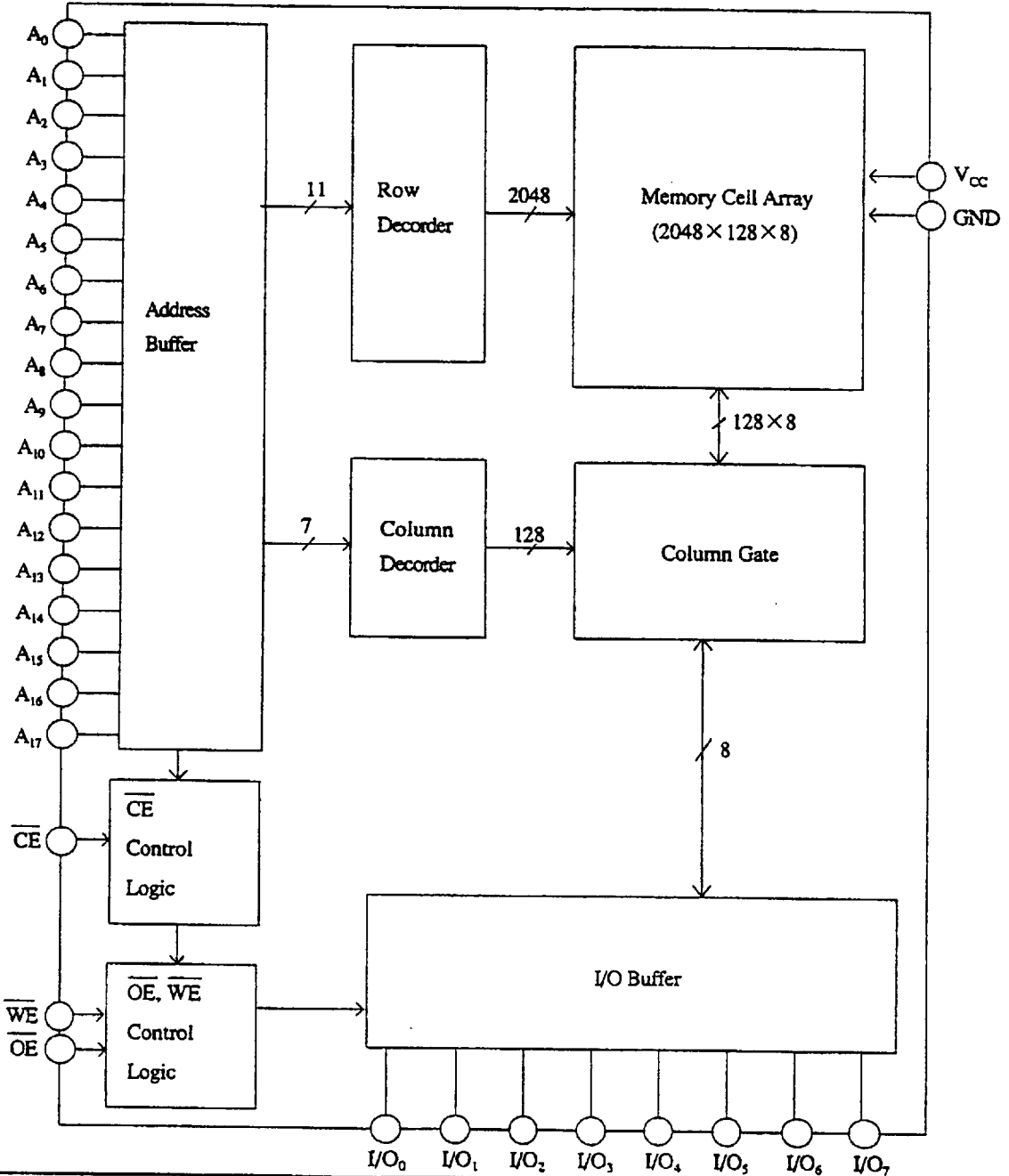

### 4. Absolute Maximum Ratings

Parameter	Symbol	Ratings	Unit
Supply voltage(*1)	$V_{CC}$	-0.2 to 4.6	V
Input voltage(*1)	$V_{IN}$	-0.3 (*2) to $V_{CC}+0.3$	V
Operating temperature	$T_{opr}$	-40 to +85	°C
Storage temperature	$T_{stg}$	-65 to +125	°C

Notes

\* 1. The maximum applicable voltage on any pin with respect to GND.

\* 2. -2.0V undershoot is allowed to the pulse width less than 50ns.

### 5. Recommended DC Operating Conditions

( $T_s = -40^\circ\text{C}$  to  $+85^\circ\text{C}$ )

Parameter	Symbol	Min.	Typ.	Max.	Unit
Supply voltage	$V_{CC}$	2.7	3.0	3.6	V
Input voltage	$V_{IH}$	2.0		$V_{CC}+0.3(*15)$	V
	$V_{IL}$	-0.3 (*3)		0.8	V

Note

\* 3. -2.0V undershoot is allowed to the pulse width less than 50ns.

### 6. DC Electrical Characteristics

( $T_s = -40^\circ\text{C}$  to  $+85^\circ\text{C}$ ,  $V_{CC} = 2.7\text{V}$  to  $3.6\text{V}$ )

Parameter	Symbol	Conditions	Min.	Typ. (*4)	Max.	Unit
Input leakage current	$I_{LI}$	$V_{IN}=0\text{V}$ to $V_{CC}$	-1.0		1.0	$\mu\text{A}$
Output leakage current	$I_{LO}$	$\overline{CE}=V_{IH}$ or $\overline{OE}=V_{IH}$ or $\overline{WE}=V_{IL}$ $V_{IO}=0\text{V}$ to $V_{CC}$	-1.0		1.0	$\mu\text{A}$
Operating supply current	$I_{CC1}$	$\overline{CE}=V_{IL}$ , $V_{IN}=V_{IL}$ or $V_{IH}$			35	mA
	$I_{CC2}$	$\overline{CE} \leq 0.2\text{V}$ $V_{IN}=0.2\text{V}$ or $V_{CC}-0.2\text{V}$			25	mA
Standby current	$I_{SB}$	$\overline{CE} \geq V_{CC}-0.2\text{V}$		1.0	120	$\mu\text{A}$
	$I_{SB1}$	$\overline{CE}=V_{IH}$			3.0	mA
Output voltage	$V_{OL}$	$I_{OL}=2.0\text{mA}$			0.4	V
	$V_{OH}$	$I_{OH}=-1.0\text{mA}$	2.4			V

Note

\* 4.  $T_s=25^\circ\text{C}$ ,  $V_{CC}=3.0\text{V}$

## 7. AC Electrical Characteristics

### AC Test Conditions

Input pulse level	0.6V to 2.2V
Input rise and fall time	5ns
Input and Output timing Ref. level	1.5V
Output load	1TTL+C <sub>L</sub> (30pF) (*5)

Note

\* 5. Including scope and jig capacitance.

### Read cycle

(T<sub>a</sub> = -40°C to +85°C , V<sub>CC</sub> = 2.7V to 3.6V )

Parameter	Symbol	Min.	Max.	Unit	
Read cycle time	t <sub>RC</sub>	85		ns	
Address access time	t <sub>AA</sub>		85	ns	
$\overline{\text{CE}}$ access time	t <sub>ACE</sub>		85	ns	
Output enable to output valid	t <sub>OE</sub>		45	ns	
Output hold from address change	t <sub>OH</sub>	10		ns	
$\overline{\text{CE}}$ Low to output active	t <sub>LZ</sub>	10		ns	*6
OE Low to output active	t <sub>OLZ</sub>	5		ns	*6
$\overline{\text{CE}}$ High to output in High impedance	t <sub>HZ</sub>	0	30	ns	*6
OE High to output in High impedance	t <sub>OHZ</sub>	0	30	ns	*6

### Write cycle

(T<sub>a</sub> = -40°C to +85°C , V<sub>CC</sub> = 2.7V to 3.6V )

Parameter	Symbol	Min.	Max.	Unit	
Write cycle time	t <sub>WC</sub>	85		ns	
Chip enable to end of write	t <sub>CW</sub>	75		ns	
Address valid to end of write	t <sub>AW</sub>	75		ns	
Address setup time	t <sub>AS</sub>	0		ns	
Write pulse width	t <sub>WP</sub>	65		ns	
Write recovery time	t <sub>WR</sub>	0		ns	
Input data setup time	t <sub>DW</sub>	35		ns	
Input data hold time	t <sub>DH</sub>	0		ns	
WE High to output active	t <sub>OW</sub>	5		ns	*6
WE Low to output in High impedance	t <sub>WZ</sub>	0	30	ns	*6
OE High to output in High impedance	t <sub>OHZ</sub>	0	30	ns	*6

Note

\* 6. Active output to High impedance and High impedance to output active tests specified for a ±200mV transition from steady state levels into the test load.

## 8. Timing Chart

### Read cycle timing chart (\*7)

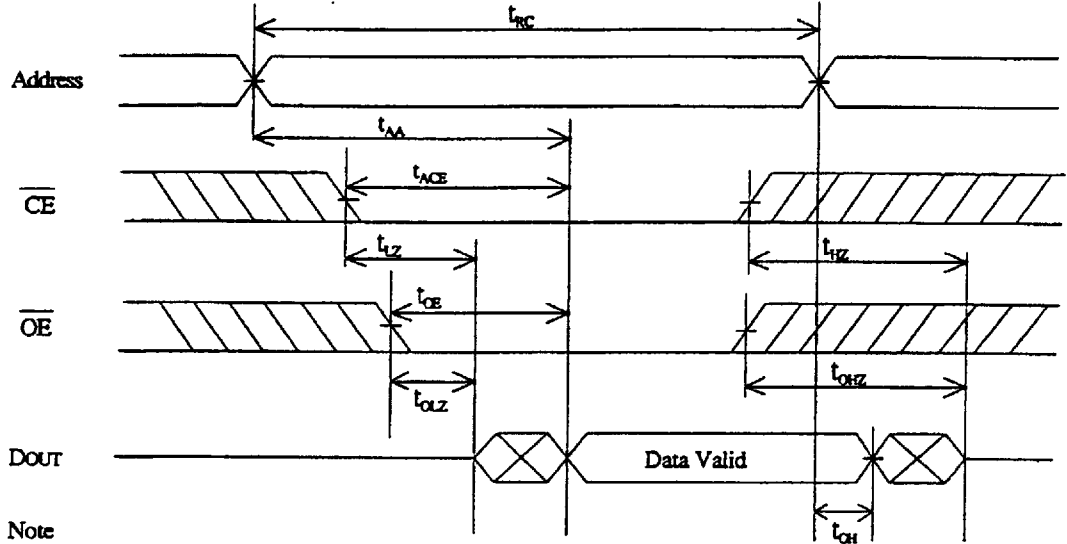

Note

\* 7.  $\overline{WE}$  is high for Read cycle.

### Write cycle timing chart ( $\overline{OE}$ Controlled)

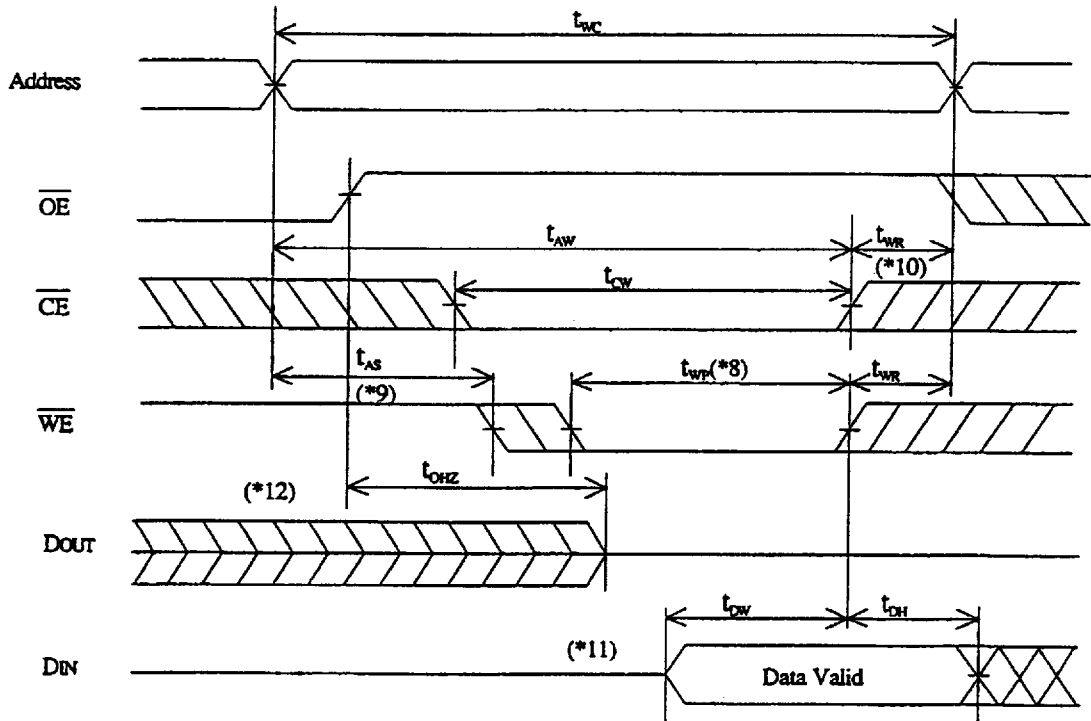

Write cycle timing chart ( $\overline{\text{OE}}$  Low fixed)

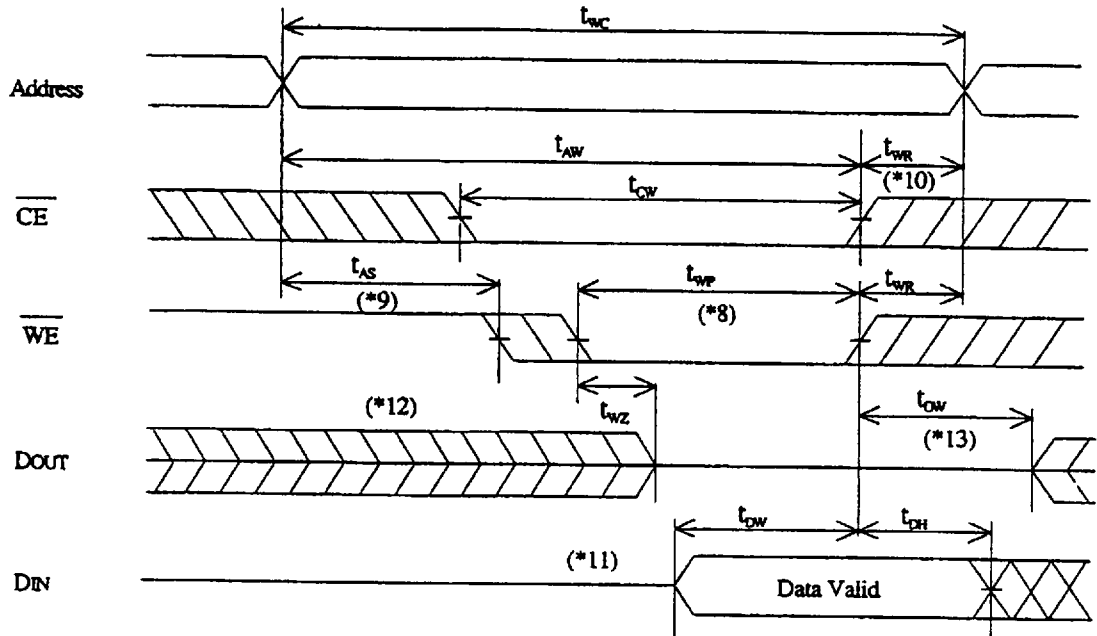

**Notes**

- \* 8. A write occurs during the overlap of a low  $\overline{\text{CE}}$  and low  $\overline{\text{WE}}$ .  
 A write begins at the latest transition among  $\overline{\text{CE}}$  going low and  $\overline{\text{WE}}$  going low.  
 A write ends at the earliest transition among  $\overline{\text{CE}}$  going high and  $\overline{\text{WE}}$  going high.  $t_{WP}$  is measured from the beginning of write to the end of write.
- \* 9.  $t_{AS}$  is measured from the address valid to the beginning of write.
- \* 10.  $t_{WR}$  is measured from the end of write to the address change.  $t_{WR}$  applies in case a write ends at  $\overline{\text{CE}}$  or  $\overline{\text{WE}}$  going high.
- \* 11. During this period, I/O pins are in the output state, therefore the input signals of opposite phase to the outputs must not be applied.
- \* 12. If  $\overline{\text{CE}}$  goes low simultaneously with  $\overline{\text{WE}}$  going low or after  $\overline{\text{WE}}$  going low, the outputs remain in high impedance state.
- \* 13. If  $\overline{\text{CE}}$  goes high simultaneously with  $\overline{\text{WE}}$  going high or before  $\overline{\text{WE}}$  going high, the outputs remain in high impedance state.

**PART4 Package and packing specification**

**1. Package Outline Specification**

Refer to drawing No. AA 2 0 2 8

**2. Markings**

**2-1. Marking contents**

(1) Product name : LRS1306

(2) Company name : SHARP

(3) Date code

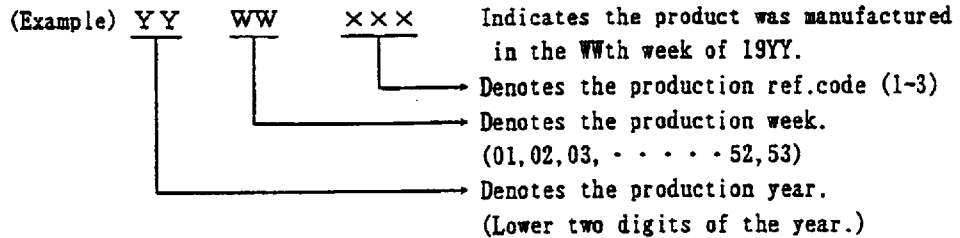

(4) The marking of "JAPAN" indicates the country of origin.

**2-2. Marking layout**

Refer drawing No. AA 2 0 2 8

(This layout does not define the dimensions of marking character and marking position.)

**3. Packing Specification (Dry packing for surface mount packages)**

Dry packing is used for the purpose of maintaining IC quality after mounting packages on the PCB (Printed Circuit Board).

When the epoxy resin which is used for plastic packages is stored at high humidity, it may absorb 0.15% or more of its weight in moisture. If the surface mount type package for a relatively large chip absorbs a large amount of moisture between the epoxy resin and insert material (e.g. chip, lead frame) this moisture may suddenly vaporize into steam when the entire package is heated during the soldering process (e.g. VPS). This causes expansion and results in separation between the resin and insert material, and sometimes cracking of the package. This dry packing is designed to prevent the above problem from occurring in surface mount packages.

**3-1. Packing Materials**

Material Name	Material Specificaiton	Purpose
Tray	Conductive plastic (60devices/tray)	Fixing of device
Upper cover tray	Conductive plastic (1tray/case)	Fixing of device
Laminated aluminum bag	Aluminum polyethylene (1bag/case)	Drying of device
Desiccant	Silica gel	Drying of device
P P band	Polypropylene (3pcs/case)	Fixing of tray
Inner case	Card board (600device/case)	Packaging of device
Label	Paper	Indicates part number, quantity and date of manufacture
Outer case	Card board	Outer packing of tray

(Devices shall be placed into a tray in the same direction.)

3-2. Outline dimension of tray  
Refer to attached drawing

4. Storage and Opening of Dry Packing

4-1. Store under conditions shown below before opening the dry packing

- (1) Temperature range : 5~40°C
- (2) Humidity : 80% RH or less

4-2. Notes on opening the dry packing

- (1) Before opening the dry packing, prepare a working table which is grounded against ESD and use a grounding strap.
- (2) The tray has been treated to be conductive or anti-static. If the device is transferred to another tray, use a equivalent tray.

4-3. Storage after opening the dry packing

Perform the following to prevent absorption of moisture after opening.

- (1) After opening the dry packing, store the ICs in an environment with a temperature of 5~25°C and a relative humidity of 60% or less and mount ICs within 72 hours after opening dry packing.

4-4. Baking (drying) before mounting

- (1) Baking is necessary
  - (A) If the humidity indicator in the desiccant becomes pink
  - (B) If the procedure in section 4-3 could not be performed
- (2) Recommended baking conditions  
If the above conditions (A) and (B) are applicable, bake it before mounting. The recommended conditions are 16-24 hours at 120°C.  
Heat resistance tray is used for shipping tray.

5. Surface Mount Conditions

Please perform the following conditions when mounting ICs not to deteriorate IC quality.

5-1. Soldering conditions (The following conditions are valid only for one time soldering.)

Mounting Method	Temperature and Duration	Measurement Point
Reflow soldering (air)	Peak temperature of 230°C or less, duration of less than 15 seconds. 200°C or over, duration of less than 40 seconds. Temperature increase rate of 1~4°C/second	IC package surface
Manual soldering (soldering iron)	260°C or less, duration of less than 10 seconds.	IC outer lead surface

5-2. Conditions for removal of residual flux

- (1) Ultrasonic washing power : 25 Watts/liter or less
- (2) Washing time : Total 1 minute maximum
- (3) Solvent temperature : 15~40°C

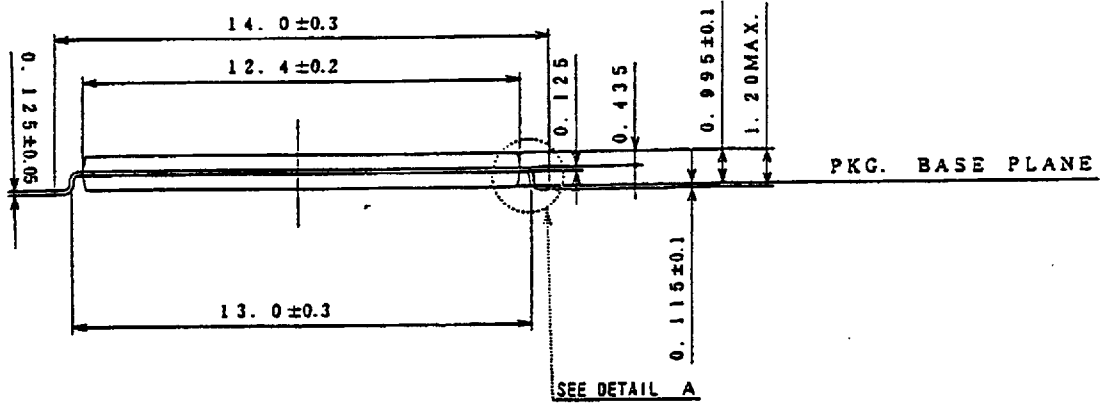
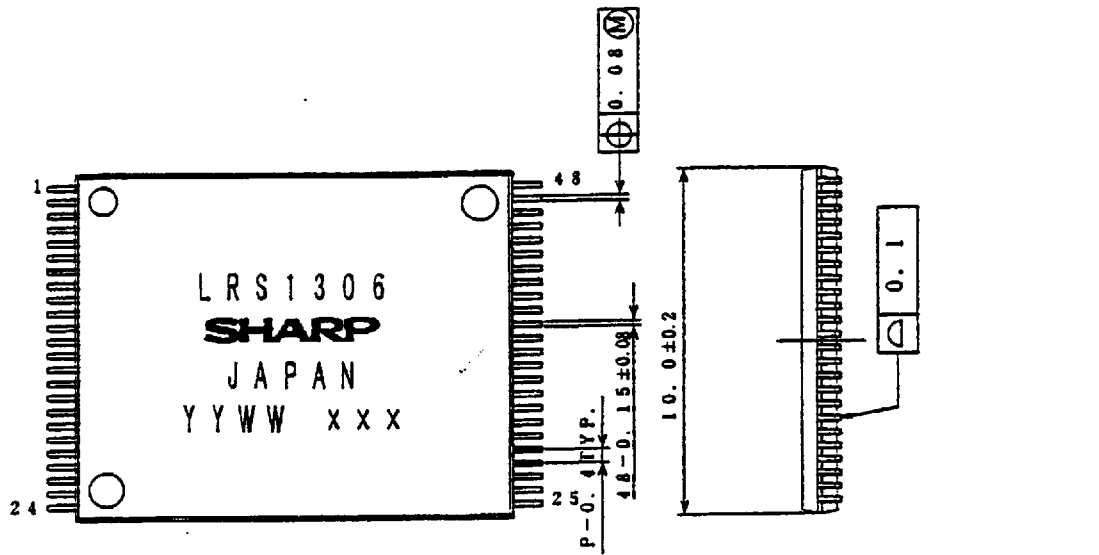

DETAIL A

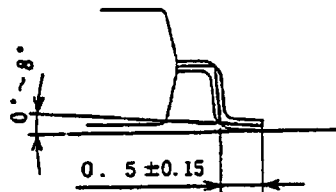

名称 NAME	TSOP48-P-1014/0.4	リード仕上 LEAD FINISH	TIN-LEAD PLATING	備考 NOTE	プラスチックパッケージ耐熱性は、Pbを含まないものとする。 Plastic body dimensions do not include burr of resin.
DRAWING NO.	AA2028	単位 UNIT	mm		



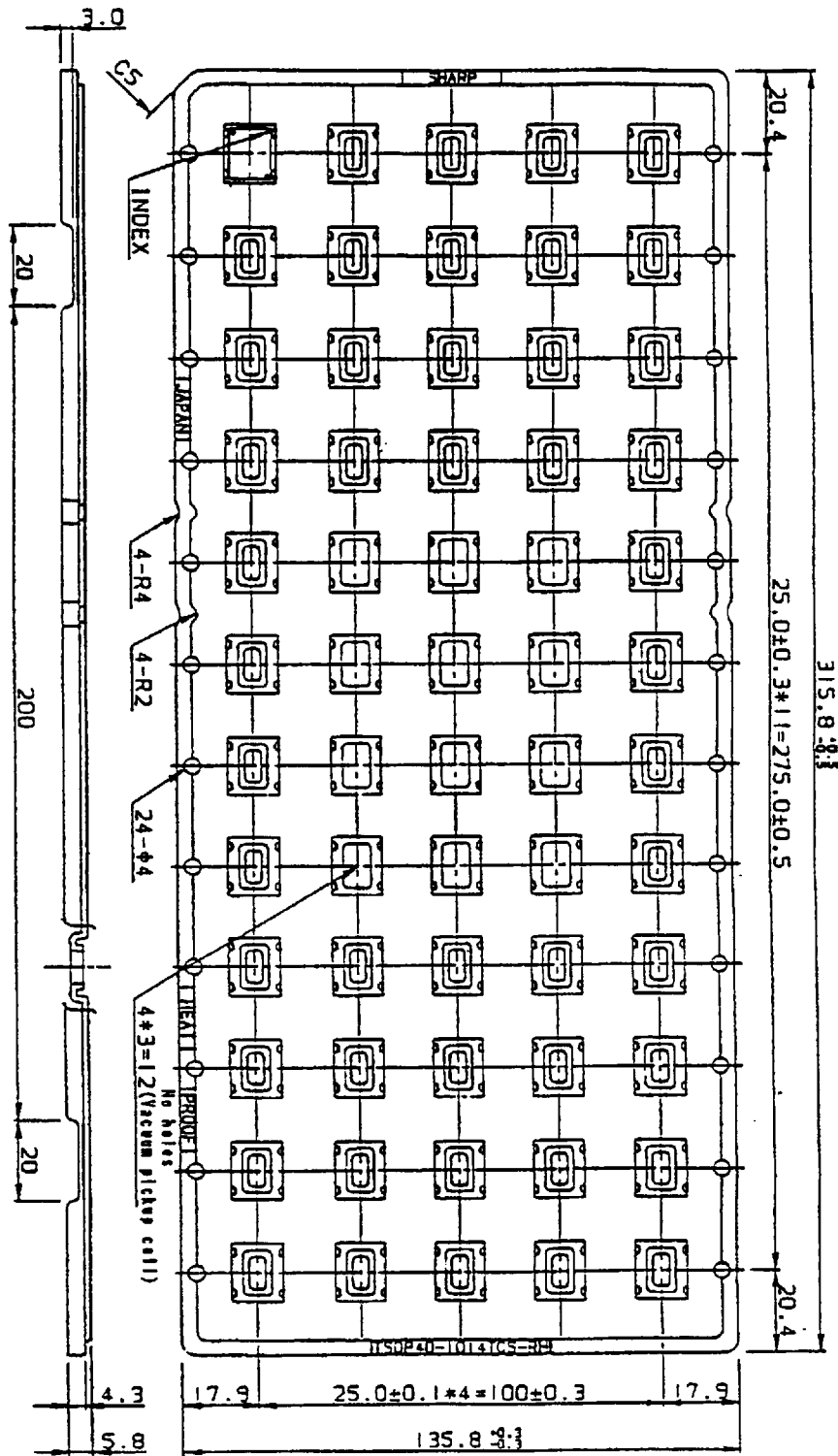

名称	TSOP40-1014TCS-RH		備考
NAME			NOTE
DRAWING NO.	CV796	単位	mm
		UNIT	