

COLLMER SEMICONDUCTOR INC 48E D ■ 2238792 0001802 064 ■ COL

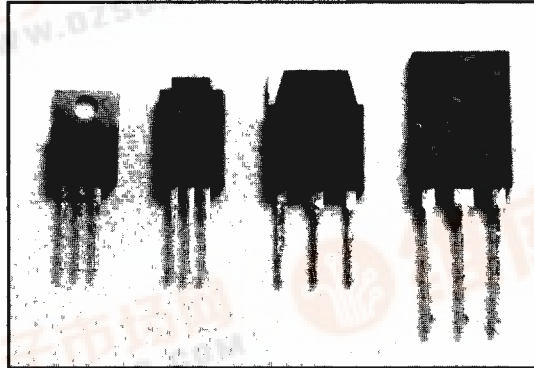

T-39-13

MOSFET Transistors

Power MOSFET Advantages:

- F-I Series Low RDS (on)
- F-II Series VGS +/- 30V Reduced turn off time
- FAP-II Series High avalanche ruggedness VGS +/- 30V, Reduced turn off time
- F-III Series Logic level operation, low RDS (on), high gfs
- F-V Series High diode di/dt rating, fast diode recovery time, 100 nsec, improved turn on loss.

Power MOSFETs are used on:

- Switching power supplies
- Motor speed controls
- DC/DC converters
- Inverters
- Uninterruptible power supplies
- Flicker free data monitors
- Electronic ballasts
- Battery chargers

FUJI Semiconductors • Imported and Distributed by
Collmer Semiconductor, Inc.

14368 PROTON RD • DALLAS, TEXAS 75244 • 214/233-1589
FAX 214/233-0481



F-I Series 50-900 Volts

Device Type	Ratings			Characteristics				Package
	V _{DSS} (V)	I _D (A)	P _D (W)	R _{DS(ON)} (Ω) (max.)	g _{fs} (S) (typ.)	t _{on} (ns) (max.)	t _{off} (ns) (max.)	
2SK905	50	45	125	0.03	25	240	800	TO3P
2SK1134	50	45	80	0.03	25	255	800	TO3PF
2SK905A	60	39	125	0.04	25	60	500	TO3P
2SK906	100	32	125	0.06	20	180	680	TO3P
2SK906A	120	30	125	0.07	20	60	500	TO3P
2SK900	250	12	80	0.30	9	120	390	TO220
2SK947	250	12	40	0.30	9	120	390	TO220F
2SK948	250	12	100	0.30	9	120	390	TO3P
2SK901	250	20	125	0.15	15	160	780	TO3P
2SK1549	250	20	80	0.15	15	160	780	TO3PF
2SK902	250	30	150	0.10	20	310	1550	TO3P
2SK901A	270	20	125	0.19	15	160	780	TO3P
2SK902A	270	30	150	0.13	20	310	550	TO3P
2SK949	500	6	40	1.20	7	100	360	TO220F
2SK950	500	6	80	1.20	7	100	360	TO220
2SK723	500	7	125	1.10	7	65	240	TO3P
2SK724	500	10	100	0.67	10	195	570	TO3P
2SK1099	500	10	80	0.67	10	195	570	TO3PF
2SK725	500	15	125	0.38	16	195	570	TO3P
2SK899	500	18	125	0.33	16	195	570	TO3P
2SK897	550	4	40	1.50	5	100	360	TO220F
2SK725A	550	15	125	0.45	16	75	430	TO3P
2SK1550	600	4	40	1.80	5	40	270	TO220F
2SK1662M	700	3	40	5.50	2	83	203	TO220F15
2SK903	800	3	40	4.00	4	90	340	TO220F
2SK904	800	3	80	4.00	4	90	340	TO220
2SK954	800	3	100	4.00	4	90	340	TO3P
2SK1105	800	3	80	4.00	4	90	340	TO3PF
2SK1663	800	3	80	4.00	4	90	340	T-PACK L,S,
2SK1384	800	5	80	2.00	6	170	630	TO3PF
2SK955	800	5	125	2.00	6	170	630	TO3P
2SK960	900	3	40	5.00	4	90	340	TO220F
2SK961	900	3	80	5.00	4	90	340	TO220
2SK726	900	3	100	5.00	4	90	340	TO3P
2SK1659	900	3	80	5.00	4	30	250	T-PACK L,S,
2SK727	900	5	125	2.50	6	170	630	TO3P
2SK1212	900	5	80	2.50	6	170	630	TO3PF

F-II Series 250/450/500/600 Volts

2SK1221	250	10	80	0.40	4.5	90	225	TO220
2SK1006	450	5	40	1.60	3.0	95	200	TO220F
2SK1007	450	5	60	1.60	3.0	95	200	TO220
2SK1009	450	7	80	1.30	4.0	110	200	TO220
2SK1386	450	7	100	1.30	4.0	110	200	TO3P
2SK1101	450	10	50	0.65	6.5	165	360	TO220F
2SK1011	450	10	100	0.65	6.5	165	360	TO3P
2SK1660	450	10	80	0.65	6.5	45	240	TO3PF
2SK1013	450	13	125	0.60	8.0	215	370	TO3P
2SK1222	450	15	125	0.55	8.0	215	370	TO3P
2SK1015	450	18	125	0.45	10.0	260	500	TO3P
2SK1017	450	20	150	0.35	14.0	375	740	TO3P
2SK1019	450	35	300	0.20	20.0	540	1350	TO3PL
2SK1008	500	4.5	60	2.20	3.0	95	200	TO220
2SK1010	500	6	80	1.60	4.0	110	200	TO220
2SK1102	500	10	50	0.90	6.5	165	360	TO220F
2SK1503	500	10	80	0.90	6.5	165	360	TO220
2SK1504	500	10	80	0.90	6.5	45	240	T-PACK L,S,
2SK1012	500	10	100	0.90	6.5	165	360	TO3P
2SK1014	500	12	125	0.74	8.0	215	370	TO3P
2SK1016	500	15	125	0.55	10.0	260	500	TO3P
2SK1018	500	18	125	0.45	10.0	260	500	TO3P

F-II Series 800/900/1000 Volts

Device Type	Ratings			Characteristics				Package
	V _{DSS} (V)	I _D (A)	P _D (W)	R _{DS(ON)} (Ω) (max.)	g _{fs} (S) (typ.)	t _{on} (ns) (max.)	t _{off} (ns) (max.)	
2SK951	800	2.5	40	7.00	1.8	90	170	TO220F
2SK952	800	2.5	45	7.00	1.8	90	170	TO220
2SK953	800	2.5	80	7.00	1.8	90	170	TO3P
2SK1211	800	2.5	40	7.00	1.8	90	170	TO3PF
2SK1021	800	3	60	6.00	2.0	128	240	TO220
2SK1545	800	3	40	6.00	2.0	128	240	TO220F
2SK1023	800	4	60	4.50	4.0	145	255	TO220
2SK1224	800	4	50	4.50	4.0	145	255	TO3PF
2SK1171	800	4	80	4.50	4.0	145	255	TO3P
2SK1547	800	4	40	4.50	4.0	145	255	TO220F
2SK1081	800	7	125	2.20	4.5	225	380	TO3P
2SK1385	800	9	100	1.50	6.0	425	690	TO3PF
2SK956	800	9	150	1.50	6.0	425	690	TO3P
2SK957	900	2	40	8.50	1.8	90	170	TO220F
2SK958	900	2	45	8.50	1.8	90	170	TO220
2SK959	900	2	80	8.50	1.8	90	170	TO3P
2SK1022	900	2.5	60	7.30	2.0	128	240	TO220
2SK1546	900	2.5	40	7.30	2.0	128	240	TO220F
2SK1024	900	3.5	60	5.50	4.0	145	255	TO220
2SK1172	900	3.5	80	5.50	4.0	145	255	TO3P
2SK1510	900	3.5	60	5.50	4.0	45	165	T-PACK L.S.
2SK1548	900	3.5	40	5.50	4.0	45	165	TO220F
2SK1082	900	6	125	2.80	4.5	225	380	TO3P
2SK962	900	8	150	2.00	6.0	425	690	TO3P
2SK1217	900	8	100	2.00	6.0	425	690	TO3PF

F-III Series Logic Level

Device Type	Ratings			Characteristics					Package
	V _{DSS} (V)	I _D (A)	P _D (W)	R _{DS(ON)} (Ω) (max.)		g _{fs} (S) (typ.)	t _{on} (ns) (max.)	t _{off} (ns) (max.)	
				V _{GS} =4V	V _{GS} =10V				
2SK1505	30	35	40	0.037	0.022	17.0	238	720	TO220F
2SK1388	30	35	60	0.037	0.022	17.0	188	720	TO220
2SK1083	60	8	20	0.350	0.220	6.0	55	105	TO220F
2SK1096M	60	13	30	0.190	0.120	11.0	15	120	TO220F15
2SK1086	60	20	35	0.110	0.070	15.0	75	310	TO220F
2SK1387	60	35	40	0.056	0.035	18.0	99	760	TO220F
2SK1089	60	35	80	0.056	0.035	18.0	99	760	TO3P
2SK1508	60	35	60	0.056	0.035	18.0	9	530	TO220
2SK1815	60	35	50	0.056	0.035	18.0	9	530	TO3PF
2SK1389	60	50	125	0.040	0.025	36.0	230	850	TO3P
2SK1390	60	50	80	0.040	0.025	36.0	230	850	TO3PF
2SK1084	100	5	20	0.700	0.500	4.5	53	85	TO220F
2SK1097	100	8	30	0.390	0.280	7.0	60	170	TO220F
2SK1087	100	12	35	0.240	0.170	10.0	93	320	TO220F
2SK1817	100	20	40	0.120	0.080	20.0	8	530	TO220F15
2SK1090	100	20	80	0.120	0.080	20.0	83	680	TO3P
2SK1509	100	20	60	0.120	0.080	20.0	83	680	TO220
2SK1085	150	3	20	1.170	0.900	3.0	50	120	TO220F
2SK1098	150	6	30	0.650	0.500	6.0	75	170	TO220F
2SK1088	150	9	35	0.400	0.300	10.0	75	275	TO220F
2SK1091	150	15	80	0.200	0.150	18.0	83	680	TO3P
2SK1661	250	20	80	0.165	0.150	25.0	45	750	T-PACK L.S.

F-V Series (FRED MOSFETs)

2SK1276	250	20	100	0.20	12.0	125	450	TO3P
2SK1277	250	30	150	0.12	20.0	260	900	TO3P
2SK1278	500	10	100	1.10	8.0	130	440	TO3P
2SK1279	500	15	125	0.58	13.0	195	840	TO3P
2SK1280	500	18	150	0.50	15.0	270	720	TO3P

FAP-II Series (High Avalanche Ruggedness)

Device Type	Ratings			Characteristics				Package
	V _{DSS} (V)	I _D (A)	P _D (W)	R _{DS(ON)} (Ω) (max.)	g _{fs} (S) (typ.)	t _{on} (ns) (max.)	t _{off} (ns) (max.)	
2SK1819-01M	450	5	35	1.50	4.2	40	170	TO220F
2SK1009-01	450	7	80	1.30	4.0	110	200	TO220
2SK1008-01	500	4.5	60	2.20	3.0	95	200	TO220
2SK1010-01	500	6	80	1.60	4.0	110	200	TO220
2SK1012-01	500	10	100	0.90	6.5	165	360	TO3P
2SK1503-01	500	10	80	0.90	6.5	45	240	TO220
2SK1504-01	500	10	80	0.90	6.5	45	240	T-PACK L,S,
2SK1102-01	500	10	50	0.90	6.5	45	240	TO220F
2SK1014-01	500	12	125	0.74	8.0	215	370	TO3P
2SK1016-01	500	15	125	0.55	10.0	260	500	TO3P
2SK1018-01	500	18	125	0.45	10.0	260	500	TO3P
2SK1821-01M	600	2	30	6.50	1.8	6	40	TO220F
2SK1507-01	600	9	50	1.00	6.0	45	240	TO220F
2SK1554-01	650	3	30	4.50	3.0	90	188	TO220F
2SK1553-01	650	5	40	2.50	5.0	85	280	TO220F
2SK951-01	800	2.5	40	7.00	1.8	90	170	TO220F
2SK952-01	800	2.5	45	7.00	1.8	30	90	TO220
2SK953-01	800	2.5	80	7.00	1.8	30	90	TO3P
2SK1211-01	800	2.5	40	5.00	1.8	30	90	TO3PF
2SK1023-01	800	4	60	4.50	4.0	145	255	TO220
2SK1171-01	800	4	80	4.50	4.0	145	255	TO3P
2SK1547-01	800	4	40	4.50	4.0	145	255	TO220F
2SK1224-01	800	4	50	4.50	4.0	45	165	TO3PF
2SK1081-01	800	7	125	2.20	4.5	225	380	TO3P
2SK956-01	800	9	150	1.50	6.0	425	690	TO3P
2SK1385-01	800	9	100	1.50	6.0	75	450	TO3PF
2SK957-01	900	2	40	8.50	1.8	90	170	TO220F
2SK958-01	900	2	45	8.50	1.8	30	90	TO220
2SK959-01	900	2	80	8.50	1.8	30	90	TO3P
2SK1548-01	900	3.5	40	5.50	4.0	145	255	TO220F
2SK1024-01	900	3.5	60	5.50	4.0	145	255	TO220
2SK1172-01	900	3.5	80	5.50	4.0	145	255	TO3P
2SK1510-01	900	3.5	60	5.50	4.0	45	165	T-PACK L,S,
2SK1082-01	900	6	125	2.80	4.5	225	380	TO3P
2SK962-01	900	8	150	2.00	6.0	425	690	TO3P
2SK1217-01	900	8	100	2.00	6.0	75	450	TO3PF
2SK1512	900	10	150	1.20	6.0	240	525	TO3P
2SK1511	1000	5	100	3.00	3.0	121	285	TO3P

TO-220

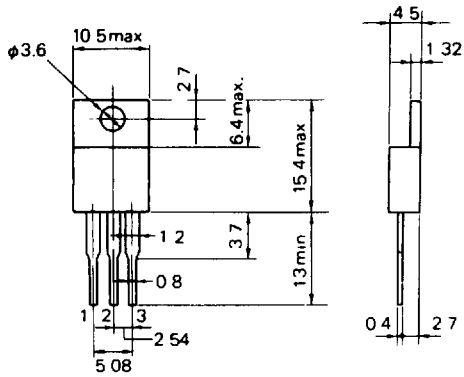

- 1 Base
- 2 Collector (case)
- 3 Emitter

Mounting torque: 3-5kg-cm

TO-3P

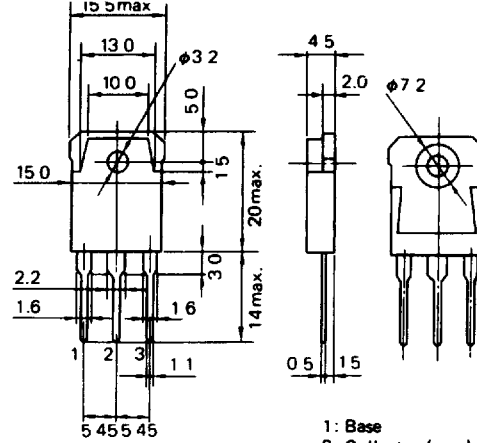

- 1: Base
- 2: Collector (case)
- 3: Emitter

Mounting torque: 4-6kg-cm

TO-220F (Full molded package)

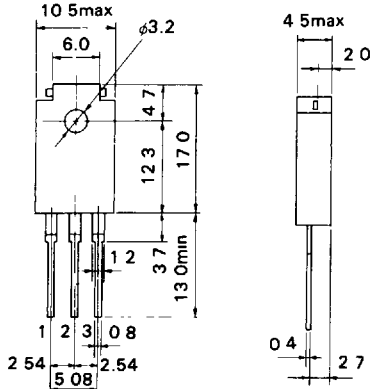

- 1 Base
- 2 Collector
- 3 Emitter

Mounting torque: 3-5kg-cm

TO-3PF (Full molded package)

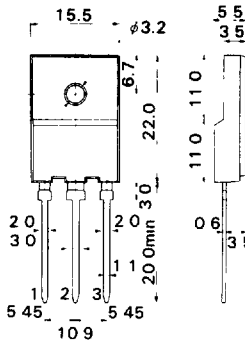

- 1 Base
- 2 Collector
- 3 Emitter

Mounting torque 4-6kg-cm

TO220F15

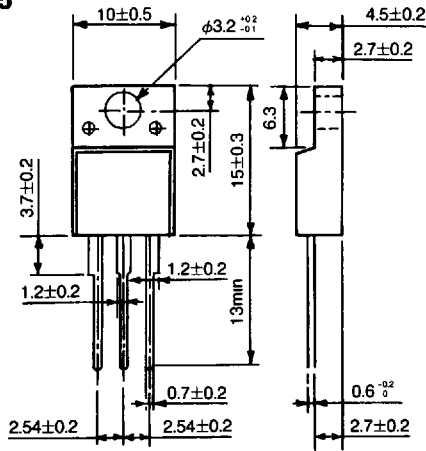

TO-3PL

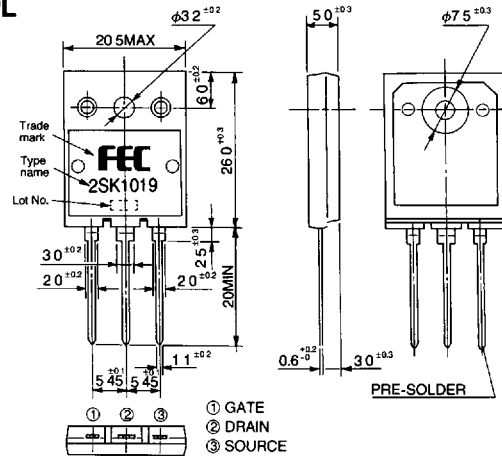

T-PACK "S"

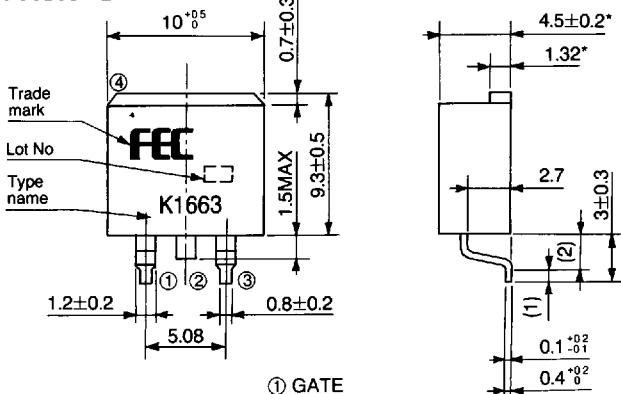

T-PACK "L"

