

# HBS-Compatible Driver and Receiver Monolithic IC MM1007

## Outline

This IC conforms to the HBS (Home Bus) specification (Electronic Industries Association of Japan), and has functions for the reception and transmission of data. AMI is adopted for the waveforms of signals handled by the transmission and reception units, designed for connection to twisted-pair lines. Telephone equipment, security devices, audio or video equipment, air-conditioning equipment, and a wide range of other devices can be connected to a bus line to enable mutual communications.

## Features

1. Compact design
2. High reliability
3. Replaces pulse transformers
4. Low cost
5. Easy circuit design
6. Few external components

## Applications

1. Telephony equipment
2. Security equipment
3. Audio and video devices
4. Air-conditioning equipment
5. Wide range of other equipment and devices

## Package

- DIP-16A (MM1007XD)
- SOP-16A (MM1007XF)

## Block Diagram

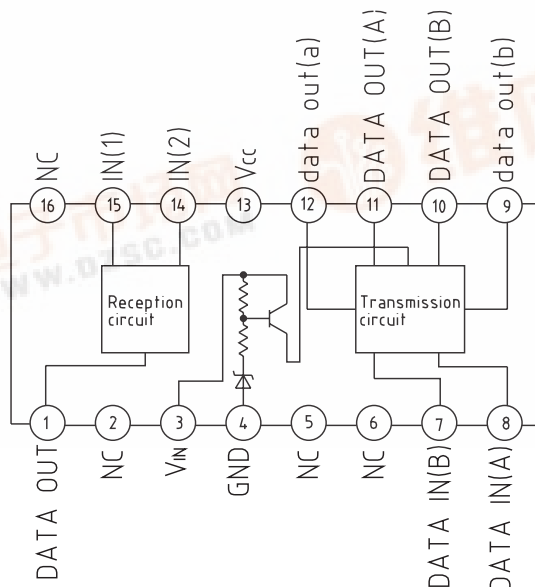

**Absolute Maximum Ratings** (Ta=25°C)

Item	Symbol	Ratings	Units
Operating temperature	T <sub>STG</sub>	-40~+125	°C
Storage temperature	T <sub>OPR</sub>	-20~+175	°C
Bias voltage	V <sub>B</sub> max.	-0.3~+41	V
Power voltage	V <sub>CC</sub> max.	-0.3~+7	V
Allowable loss	P <sub>d</sub>	450	mW
Recommended power supply voltage range	V <sub>CCOP</sub>	4.75~5.25	V
Recommended bias voltage range	V <sub>BOP</sub>	8~40	V
Operating power supply voltage range	V <sub>CCOP2</sub>	4.5~5.5	V

**Electrical Characteristics** (Except where noted otherwise, Ta=25°C, V<sub>CC</sub>=5V, V<sub>B</sub>=30V, F<sub>transmit</sub>=10kHz (DUTY=50%))

Item	Symbol	Measurement conditions	Min.	Typ.	Max.	Units
Power supply current	I <sub>CCO</sub>	No signal (7-8PIN=H)		7	10	mA
Power supply current	I <sub>CCON</sub>	In transmission F <sub>L</sub> =10k, R <sub>L</sub> =36Ω		65	75	mA
Bias current pin 3	I <sub>BO</sub>	No signal (7-8PIN=H)		220	350	μA
Bias current pin 3	I <sub>BON</sub>	In transmission F <sub>L</sub> =10k, R <sub>L</sub> =36Ω		1.5	2.2	mA
Transmission output voltage	V <sub>TO</sub>	Both pins 10 and 11	3.8	4.2	4.6	V <sub>P-P</sub>
Transmission waveform symmetry	V <sub>TR</sub>	V <sub>TO1</sub> /V <sub>TO2</sub>	0.75	1.0	1.25	
Reception sensitivity	V <sub>RS</sub>		0.65	0.75	0.85	V <sub>P-P</sub>
Noise resistance	V <sub>RN</sub>	Level at which no errors are output	0.55			V <sub>P-P</sub>
Input impedance	R <sub>IN</sub>	Both pins 14 and 15	25	36	46	kΩ
Transmission delay time 1	T <sub>d1</sub>	cf. transmit/receive waveform diagrams		0.2		μS
Transmission delay time 2	T <sub>d2</sub>	cf. transmit/receive waveform diagrams		0.4		μS
Transmission delay time 3	T <sub>d3</sub>	cf. transmit/receive waveform diagrams		0.7		μS
Transmission delay time 4	T <sub>d4</sub>	cf. transmit/receive waveform diagrams		1.0		μS
Reception output H voltage	V <sub>ROH</sub>		4.5		V <sub>CC</sub>	V
Reception output L voltage	V <sub>ROL</sub>				0.5	V
Transmission waveform LOSS1	V <sub>TLS1</sub>	H level input voltage	4.5			V
Transmission waveform LOSS2	V <sub>TLS2</sub>	L level input voltage	4.5			V
H level input voltage	V <sub>LIH</sub>		2.4			V
L level input voltage	V <sub>LIL</sub>				0.8	V
H level input current	I <sub>LIH</sub>	V <sub>IN</sub> =2.4V			10	μA
L level input current	I <sub>LIL</sub>	V <sub>IN</sub> =0.4V			-300	μA

When a negative voltage is applied to pins 10 and 11, there should be no abnormal operation of internal circuits between 0 and 6V. However, if a negative voltage exceeding -6V is applied, thyristor operation may result, so it is recommended that an external clamping diode be added.

Application Circuits

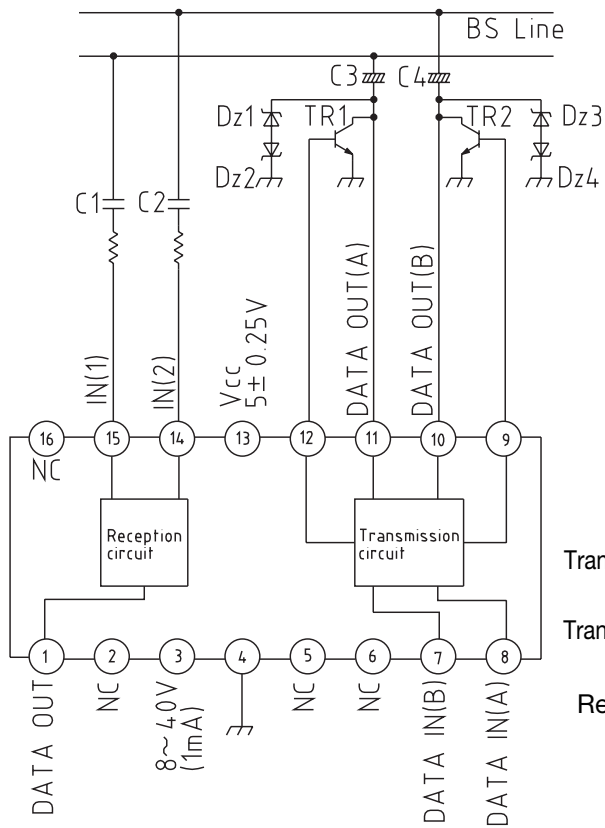

TR1, TR2	2SC2001
C1, C2	0.022μF
R1, R2	33kΩ
C3, C4	10μf
Dz1, Dz2, Dz3, Dz4	Vz=5.6V

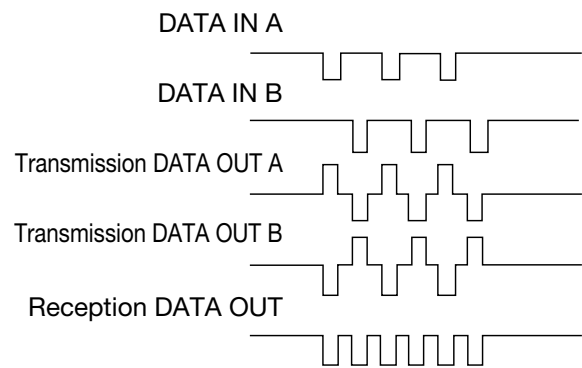

Circuit Diagram

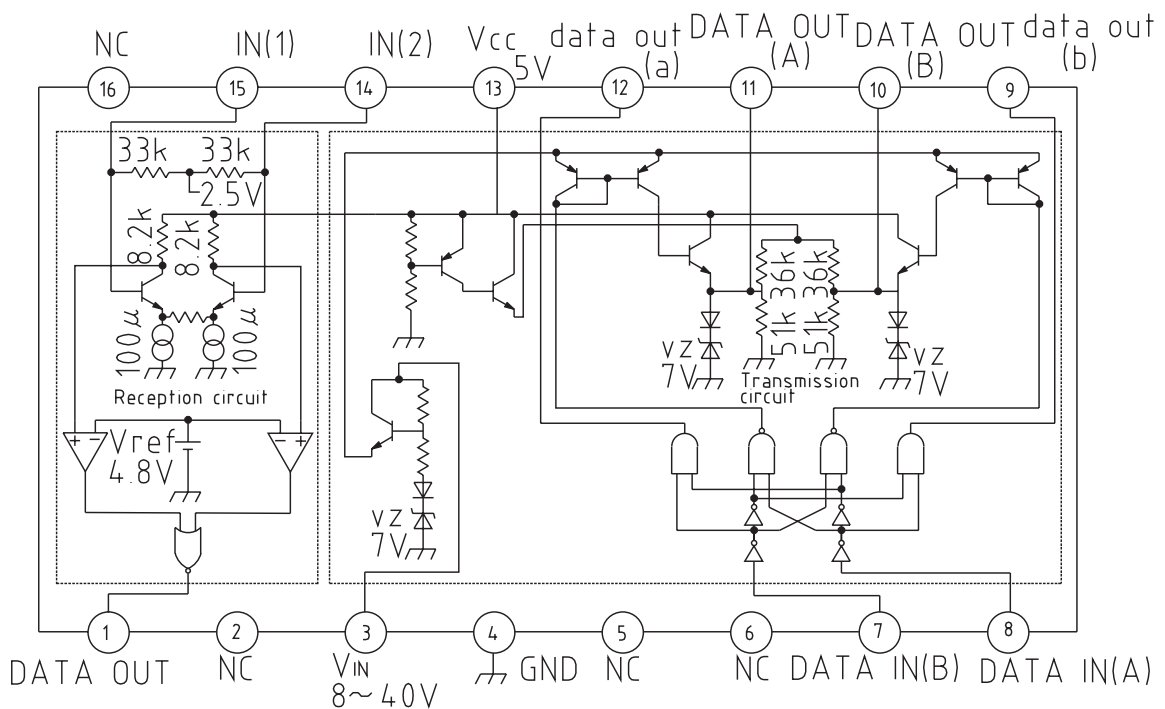

MM1007 When used with a single +5V power supply

APPLICATION 1

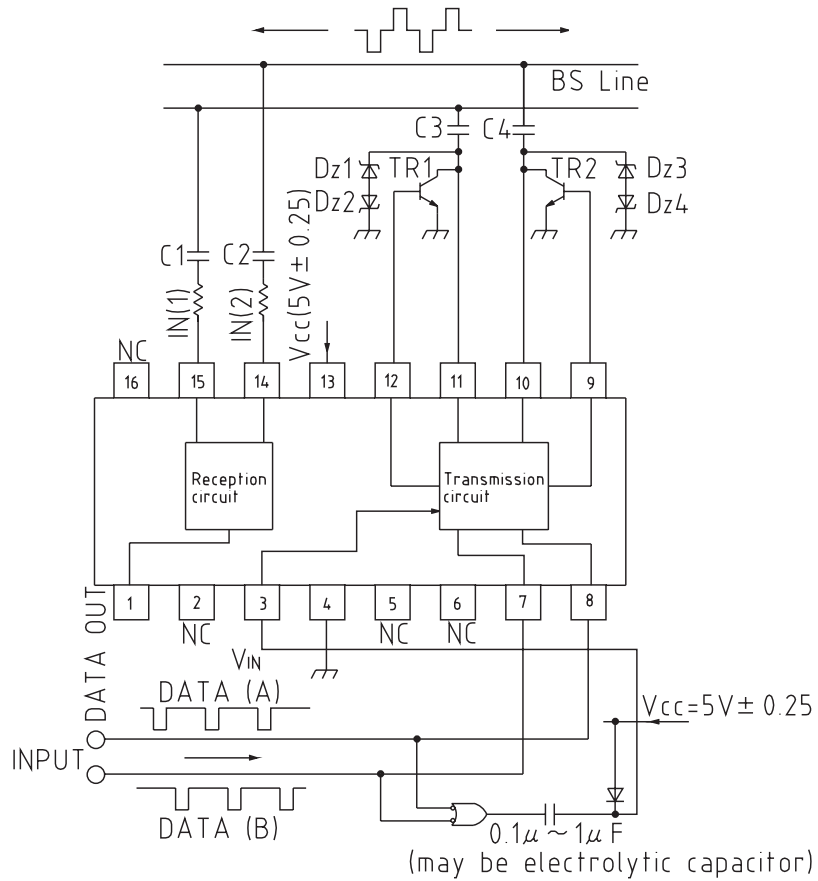

APPLICATION 2

