

1000mA Regulator Monolithic IC MM166□□F

Outline

This IC is a small, stable power supply with output voltage precision of $\pm 2\%$ (when $I_o = 500\text{mA}$), maximum output current of 1000mA, and I/O voltage difference of 0.2V typ. at 500mA. Output noise reduction and output ON/OFF control pins are provided, making it ideal for portable equipment. (HSOP-8)

Features

- | | |
|--------------------------------|--|
| 1. No-load current consumption | 2.5mA typ. |
| 2. I/O voltage difference | 0.2V typ. ($I_o=500\text{mA}$) |
| 3. Ripple rejection rate | 65dB typ. ($f=120\text{Hz}$, $V_{\text{RIPPLE}}=1\text{VP-P}$, $I_o=250\text{mA}$) |
| 4. Output current | 1000mA max. |
| 5. Output noise voltage | 45 μVrms typ. ($C_n=470\text{pF}$) |
| 6. Output voltage rank | 1.5 ~ 5.0V (0.1V steps) |
| 7. Output ON/OFF control | High \rightarrow ON, Low \rightarrow OFF |

Package

HSOP-8, TO-252

Applications

1. Cordless telephone
2. Portable equipment, etc.
3. DVD

Pin Assignment

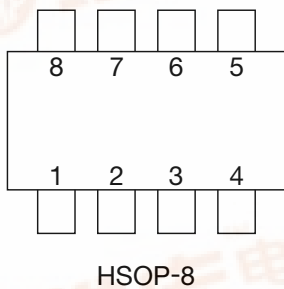

1	V_{OUT}
2	NC
3	GND
4	C_n
5	CONT
6	NC
7	NC
8	V_{IN}

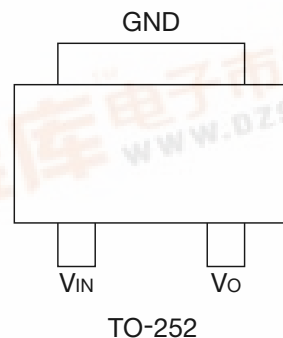

Equivalent Circuit Diagram

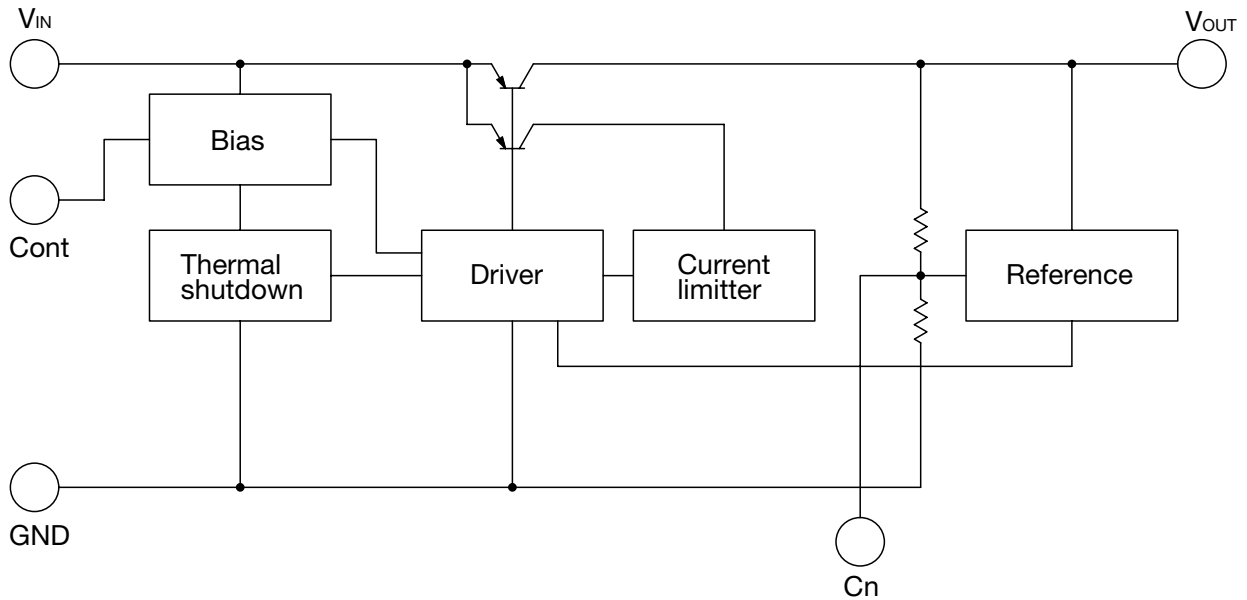

Pin Description

HSOP-8

Pin No.	Pin name	Function	Internal equivalent circuit diagram
1	V _{OUT}	Output pin	
2	NC	No connection	
3	GND	Ground	
4	C _n	Noise decrease pin	

Pin No.	Pin name	Function	Internal equivalent circuit diagram						
5	Cont	Control pin <table border="1" style="margin-left: 20px;"> <tr> <td>Cont</td> <td>Output</td> </tr> <tr> <td>H</td> <td>ON</td> </tr> <tr> <td>L</td> <td>OFF</td> </tr> </table>	Cont	Output	H	ON	L	OFF	
Cont	Output								
H	ON								
L	OFF								
6	NC	No connection							
7	NC	No connection							
8	V_{IN}	Input pin							

TO-252

Pin No.	Pin name	Function	Internal equivalent circuit diagram
1	V_{IN}	Input pin	
2	GND	Ground	
3	V_{OUT}	Output pin	

Absolute Maximum Ratings (Ta=25°C)

Item	Symbol	Ratings	Units
Storage temperature	T _{STG}	-40~+150	°C
Supply voltage	V _{IN}	-0.3~+12	V
Allowable loss	Pd	2500 (TO-252) 1800 (HSOP-8)	mW

*1 TO-252 : With the double sided PC Board of glass epoxy
(Copper plane 80%, 100×150×1.0mm)
HSOP-8 : With the double sided PC Board of glass epoxy
(Copper plane 80%, 37×37×1.6mm)

Recommended Operating Conditions

Item	Symbol	Ratings	Units
Operating temperature	T _{OPR}	-40~+85	°C
Output current	I _{OUT}	0~1	A
Operating voltage	V _{OP}	V _O Typ.+0.5~+10	V

Electrical Characteristics 1 (Except where noted therwise, Ta=25°C, V_{CC}=9V)

Item	Symbol	Measurement conditions	Min.	Typ.	Max.	Units
No-Load input current	I _{CC}	I _O =0mA		2.5	5	mA
Input current (OFF)	I _{CCOFF}	V _{CONT} =0V		0	1	μA
Output voltage *3	V _{OUT}	I _O =250mA	×0.98		×1.02	V
Dropout voltage *4	V _{IO}	V _{IN} =V _O -0.2V, I _O =500mA		0.2	0.5	V
Line regulation	ΔV ₁	V _{IN} =V _O +1.5~V _O +2.5V, I _O =250mA		10	20	mV
Load regulation	ΔV ₂	I _O =0~1A		20	100	mV
V _{OUT} temperature coefficient *2	ΔV _{OUT} /ΔT	T _j =-30~+85°C		100		ppm/°C
Ripple rejection *2	RR	f=120Hz V _{RIPPLE} =1V, I _O =250mA	50	65		dB
Output noise voltage *2	V _n	fBW=20~80kHz C _n =470pF I _O =250mA		45		μV _{rms}
		fBW=20~80kHz C _n =OPEN I _O =250mA		90		
CONT pin input current	I _{CONT}	V _{CONT} =5V	10	20	30	μA
CONT pin high threshold level	V _{CONTH}		1.6		V _{IN} +0.3	V
CONT pin low threshold level	V _{CONTL}		-0.3		0.4	V

*2. The parameter is guaranteed by design.

*3. Please refer to another page.

*4. The parameter is not guaranteed in the model less than V_{OUT}=2V.

Electrical Characteristics 2

Output Voltage

Product name	Test conditions	Output voltage		
		Min.	Typ.	Max.
MM1661F	Io=250mA	1.470	1.5	1.530
MM1661G		1.568	1.6	1.632
MM1661H		1.666	1.7	1.734
MM1661J		1.764	1.8	1.836
MM1661K		1.862	1.9	1.938
MM1662A		1.960	2.0	2.040
MM1662B		2.058	2.1	2.142
MM1662C		2.156	2.2	2.244
MM1662D		2.254	2.3	2.346
MM1662E		2.352	2.4	2.448
MM1662F		2.450	2.5	2.550
MM1662G		2.548	2.6	2.652
MM1662H		2.646	2.7	2.754
MM1662J		2.744	2.8	2.856
MM1662K		2.842	2.9	2.958
MM1663A		2.940	3.0	3.060
MM1663B		3.038	3.1	3.162
MM1663C		3.136	3.2	3.264
MM1663D		3.234	3.3	3.366
MM1663E		3.332	3.4	3.468
MM1663F	3.430	3.5	3.570	
MM1663G	3.528	3.6	3.672	
MM1663H	3.626	3.7	3.774	
MM1663J	3.724	3.8	3.876	
MM1663K	3.822	3.9	3.978	

Product name	Test conditions	Output voltage		
		Min.	Typ.	Max.
MM1664A	Io=250mA	3.920	4.0	4.080
MM1664B		4.018	4.1	4.182
MM1664C		4.116	4.2	4.284
MM1664D		4.214	4.3	4.386
MM1664E		4.312	4.4	4.488
MM1664F		4.410	4.5	4.590
MM1664G		4.508	4.6	4.692
MM1664H		4.606	4.7	4.794
MM1664J		4.704	4.8	4.896
MM1664K		4.802	4.9	4.998
MM1665A		4.900	5.0	5.100

Measuring Circuit

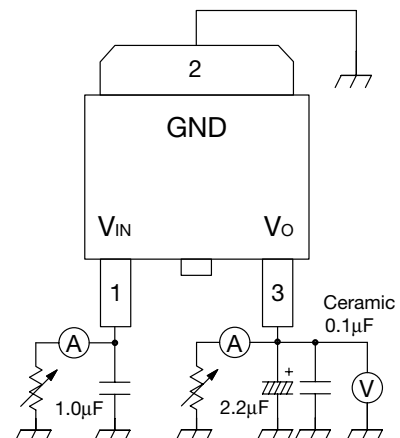
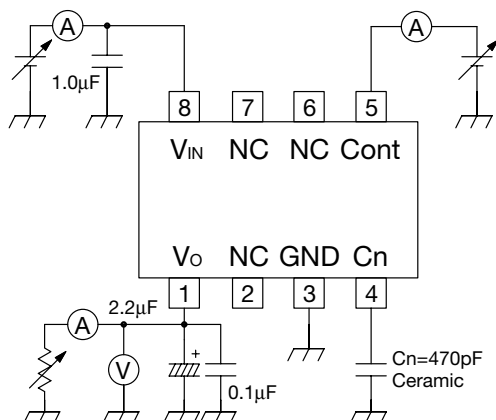

Application Circuit

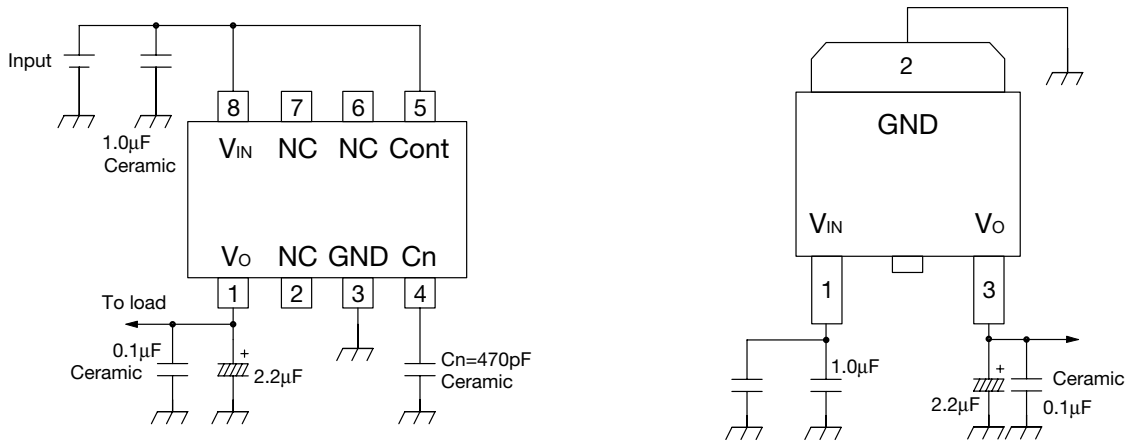

Note

1. The output capacitor is required between output and GND to prevent oscillation.
2. The ESR of capacitor must be defined in ESR stability area.
3. The wire of Vcc and GND is required to print full ground plane for noise and stability.
4. The input capacitor must be connected a distance of less than 1cm from input pin.
5. The capacitor is connected to Cn must have low leakage current characteristics, because Cn pin is high impedance.
6. In case the output voltage is above the input voltage, the overcurrent flow by internal parasitic diode from output to input. In such application, the external bypass diode must be connected between output and input pin.

Characteristics (3.0V product Except where noted otherwise, Ta=25°C, VIN=5V, VCONT=5V, CIN=1µF, Co=2.2µ)

About Power dissipation

This IC's GND pin and Heat Spreader Bottom effectively radiate heat. By increasing these copper foil pattern area of PCB, Power dissipation improves. Please kindly design PCB pattern taking care of above features about power dissipation.

Power Dissipation

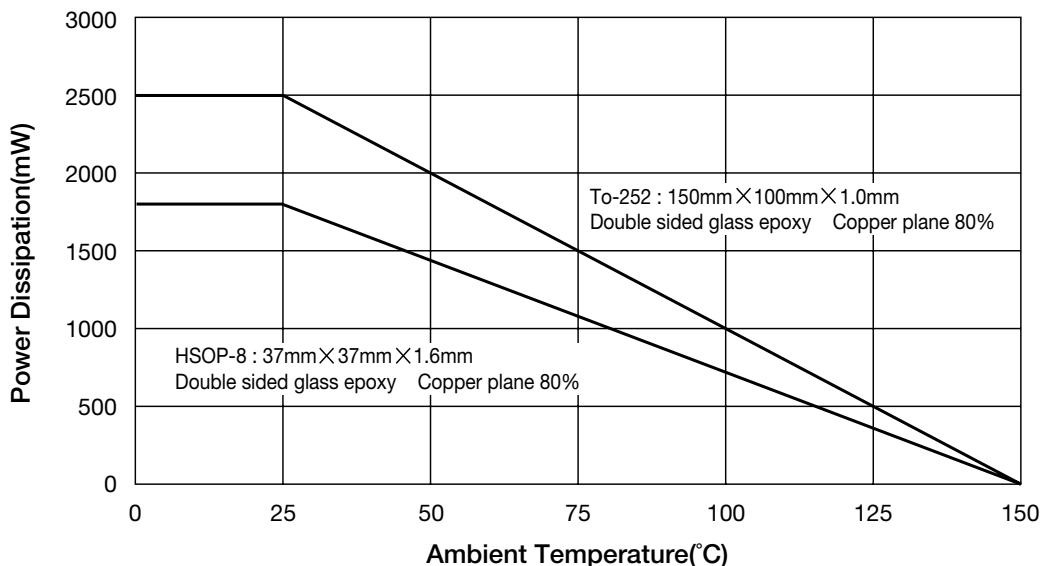

Input Voltage-Output Voltage

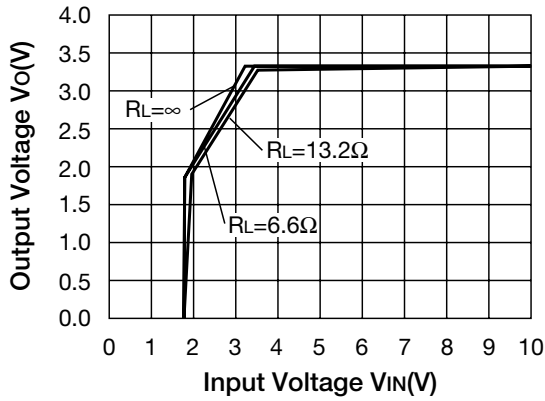

Input Current-Input Voltage

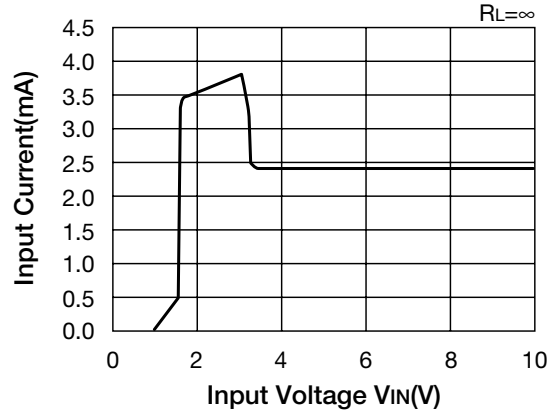

Load Regulation

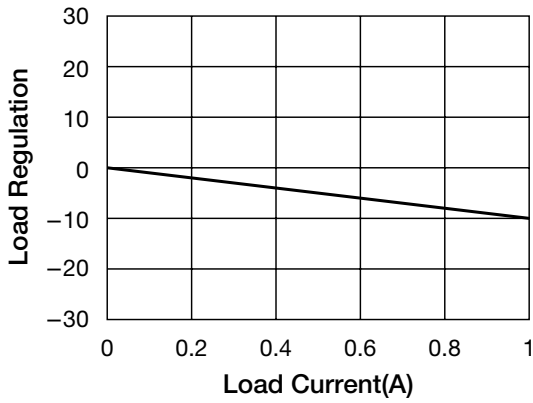

Line Regulation

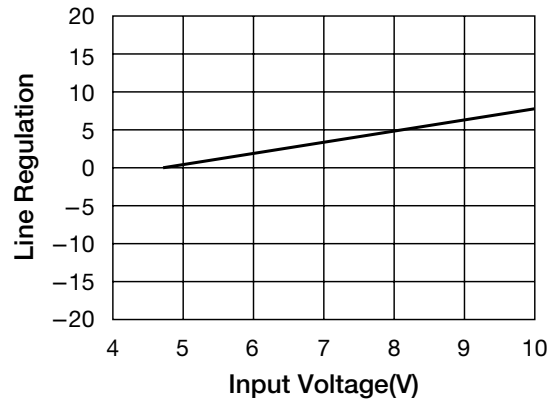

Dropout Voltage

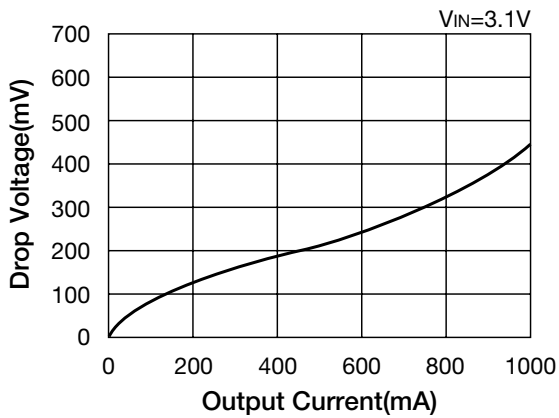

Output Voltage-Temperature

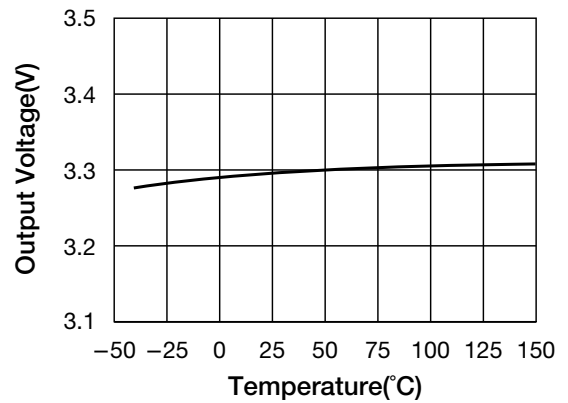

■ Ripple Rejection

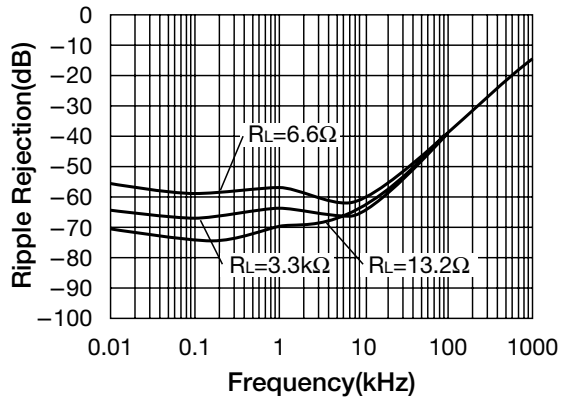

■ Current Limit

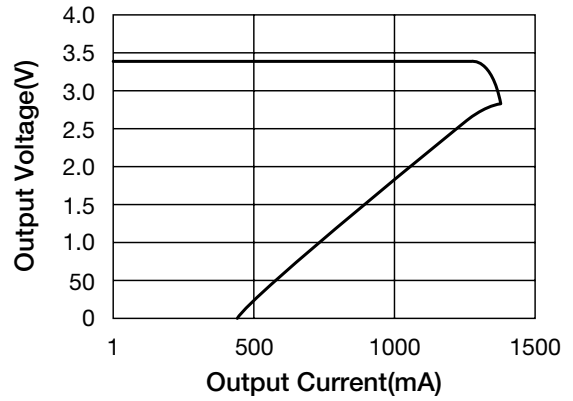

■ GND Pin Current

