

Type F
**Hot-Molded
 Trimming Potentiometers**

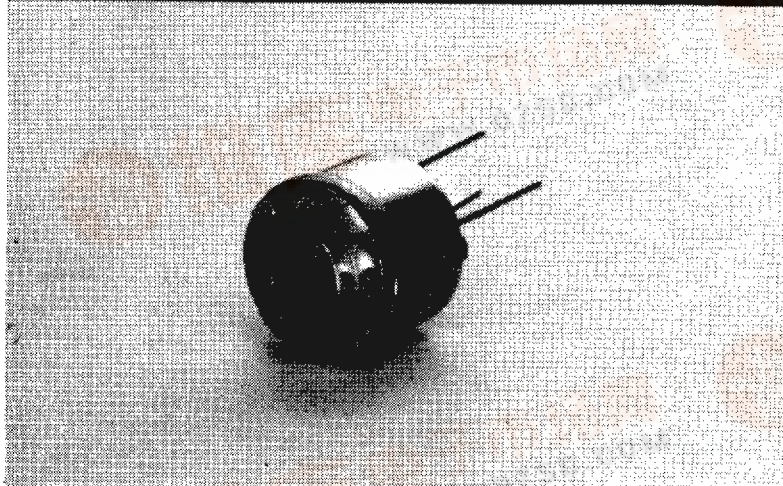

Features

- 5000 Mechanical Cycles
- Linear and Non-Linear Tapers
- Immersion Sealed

Benefits

- Very Long Rotational Life
- Versatility
- Washable

AVAILABILITY

Groupings

The Type F Hot-Molded Trimming Potentiometers are available as follows.

OEM standard components— These OEM components (Resistance Value listed in the table on Page 268) are stocked as components at our manufacturing facilities. They offer a wider range of possible combinations than

the distributor stocked final assemblies but do require assembly.

All custom components— All other components listed are available. Since they are not stocked, they require both fabrication and assembly.

SPECIFICATIONS

General

Temperature range — -55°C to $+120^{\circ}\text{C}$.

Total resistance range — 100 ohms to 5 Megohms.

Total resistance tolerances — $\pm 20\%$ or $\pm 10\%$.

End resistance — See chart and notes on Page 267.

Taper — See chart on Page 267 for explanation of tapers. Special tapers, where practical, can be supplied.

Dielectric withstanding voltage — 750 volts at sea level for one second.

Insulation resistance — 1000 megohms minimum.

Voltage characteristic — 0.005 percent per volt or 0.5 ohm, whichever is greater.

Electrical

65E D ■ 2158675 0001028 T41 ■

Power — 0.25 watt maximum at +70°C for "U" linear taper, provided voltage rating is not exceeded.

Power derating — Derate power linearly from +70°C wattage to zero at +120°C. Derate 50 percent for "A", "B", "S", or "DB" tapers. For rheostat

applications derate directly with shaft or actuator position.

Voltage — 350 volts maximum working voltage within power rating limits.

Operational

Contact resistance variation — Less than 3 percent of nominal total resistance value.

Load life — 10 percent maximum change in total resistance as a result of 1000 hour test at rated power across entire element in still air at +70°C. (1.5 hours "ON" — 0.5 hour "OFF".)

Rotational life — 10 percent maximum change in total resistance as a result of 5000 mechanical cycles under load.

Mechanical

Rotation — Mechanical rotation is 295° ± 5°. Electrical rotation is 270° nominal.

Turning torque — 0.25 to 3.0 inch-ounces (0,018 to 0,216 kgf-cm) at +25°C.

Stop torque — Will withstand greater than 10 inch-ounces (0,72 kgf-cm) shaft torque.

Backlash — Maximum of 3°.

Construction — Materials essentially non-magnetic. Enclosure is immersion sealed.

Terminals are treated for easy soldering.

Weight — Approximately 7 grams.

Marking — Clarostat part number and nominal total resistance are marked in two lines. Other marking possible limited to two lines. On types FR, FC, FP and FM space permits 16 characters per line. On types FH and FS space permits 8 characters per line. "Type F" always included.

Environmental

Washability — Type F trimmers will withstand typical after-solder boardwash processes using approved detergent and solvent solutions.

PARAMETER	MAXIMUM CHANGE	TEST METHOD
Vibration	2% Total Resistance 5% Setting Stability	Method 204, Cond. C, MIL-STD-202
Shock	2% Total Resistance 5% Setting Stability	Method 213, Cond. I, MIL-STD-202
Moisture Resistance	10% Total Resistance	Method 106, MIL-STD-202
Effect of Soldering	2% Total Resistance	MIL-R-94, Par. 4.6.6
Low Temperature Storage	2% Total Resistance	MIL-R-94, Par. 4.6.11
Low Temperature Operation	2% Total Resistance	MIL-R-94, Par. 4.6.12
Temperature Cycling	3% Total Resistance	MIL-R-94, Par. 4.6.13

NOTE: Unless otherwise specified, Terms, Definitions and Test Procedures are in accordance with Variable Resistive Components Institute Standards vrci-t-110 and vrci-215. Maximum environmental change is specified as 2 ohms on resistive values where 2 ohms exceeds the specified percentage change.

Temperature characteristics — Maximum percent temporary total resistance change from the +25°C value.

Nominal Resistance	Degrees Celsius						
	-55°	-25°	0°	+25°	+55°	+85°	+120°
100 Ohms	+ 4.5	+2.5	+1.5	0	± 1.0	± 1.5	+ 3.5
1000 Ohms	+ 5.5	+3.0	+1.5	0	± 1.0	± 2.0	+ 4.5
10,000 Ohms	+ 7.0	+3.5	+2.0	0	± 1.0	± 2.5	+ 5.5
100,000 Ohms	+ 8.0	+4.0	+2.0	0	± 1.5	± 3.0	+ 6.0
1 Megohm	+10.0	+5.0	+2.5	0	± 1.5	± 3.5	+ 7.5

Taper Data

65E D ■ 2158675 0001029 988 ■

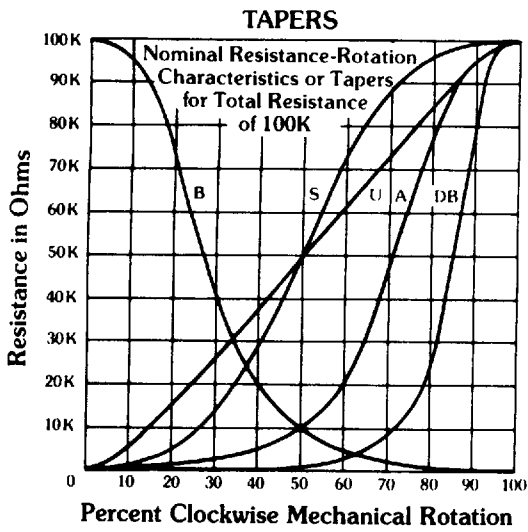

END RESISTANCE

TAPER	MINIMUM RESISTANCE BETWEEN TERMINALS 1 and 2	MINIMUM RESISTANCE BETWEEN TERMINALS 2 and 3
U & S	1	1
A	1	2
B	2	1
DB	3	2

- 1 Less than .004% of total resistance, or less than 15 ohms whichever is greater.
- 2 Less than 1% of total resistance, or less than 15 ohms whichever is greater.
- 3 Less than 15 ohms.

Tapers A, DB, S and U are measured between the wiper and the counter-clockwise terminals; taper B is measured between the wiper and the clockwise terminals.

Hot-Molded Trimming Potentiometers

Explanation of Part Numbers

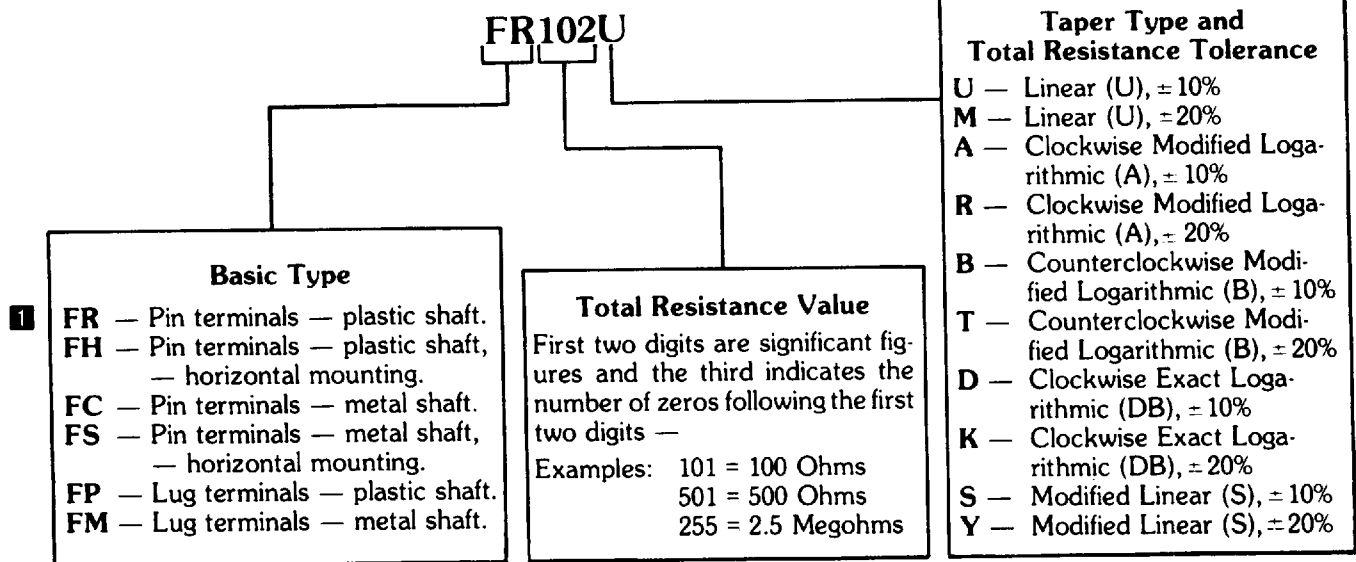

Available Special Order Number Values

Basic Type		F	
Terminals		Lug or Pin	
Tolerance		10% or 20%	
Resistance (ohms)	Code	Taper	
		"U"	"A" or "B"
100	101	—	*
1000	102	—	—
10000	103	—	—
100000	104	—	—
1000000	105	—	—
150	151	—	*
1500	152	—	—
15000	153	—	—
150000	154	—	—
200	201	—	*
2000	202	—	—
20000	203	—	—
200000	204	—	—
2000000	205	—	—
250	251	—	*
2500	252	—	—
25000	253	—	—
250000	254	—	—
2500000	255	—	—
500	501	—	—
5000	502	—	—
50000	503	—	—
500000	504	—	—
5000000	505	—	—

Available Catalog Order Number Values

Basic Type		FR	
Resistance (ohms)	Code	"U" or "M" Taper	
100	101	—	
1000	102	—	
10000	103	—	
100000	104	—	
1000000	105	—	
200	201	—	
2000	202	—	
20000	203	—	
200000	204	—	
2000000	205	—	
250	251	—	
2500	252	—	
25000	253	—	
250000	254	—	
2500000	255	—	
500	501	—	
5000	502	—	
50000	503	—	
500000	504	—	
5000000	505	—	

— = Available as a Special Order only. Contact factory for information.

DIMENSIONS

Type FC, Type FR

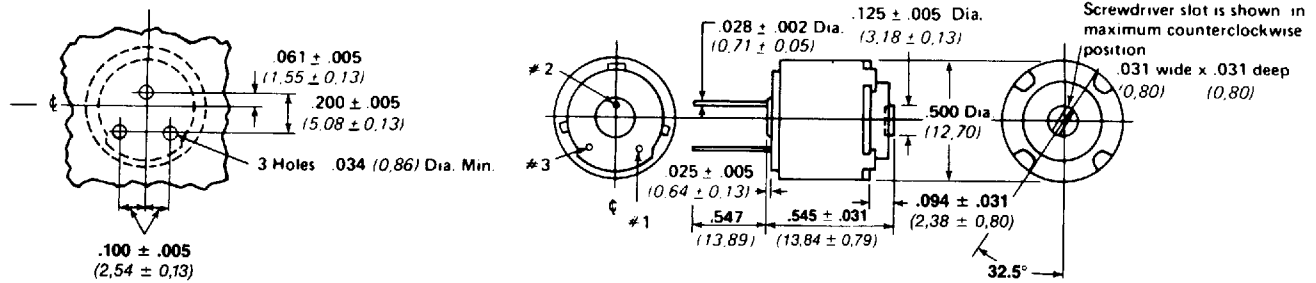

Type FH, Type FS

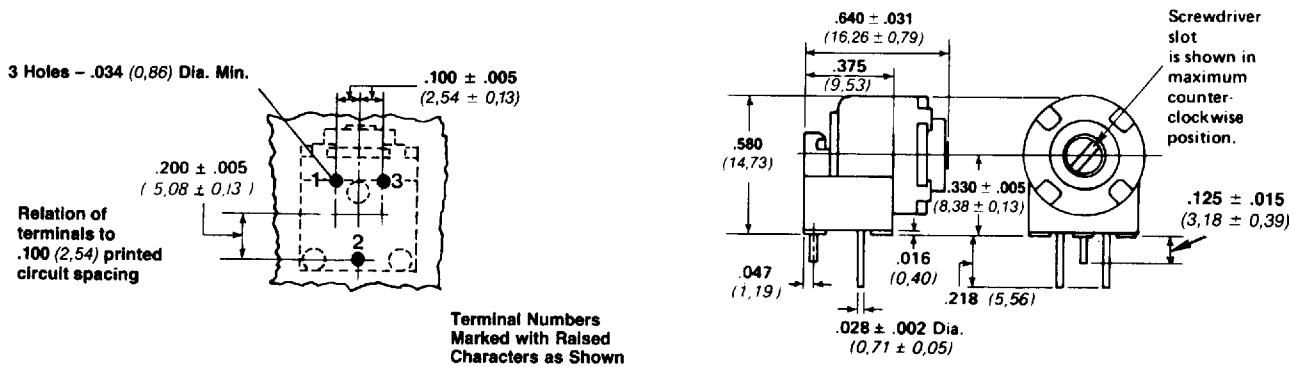

Type FM, Type FP

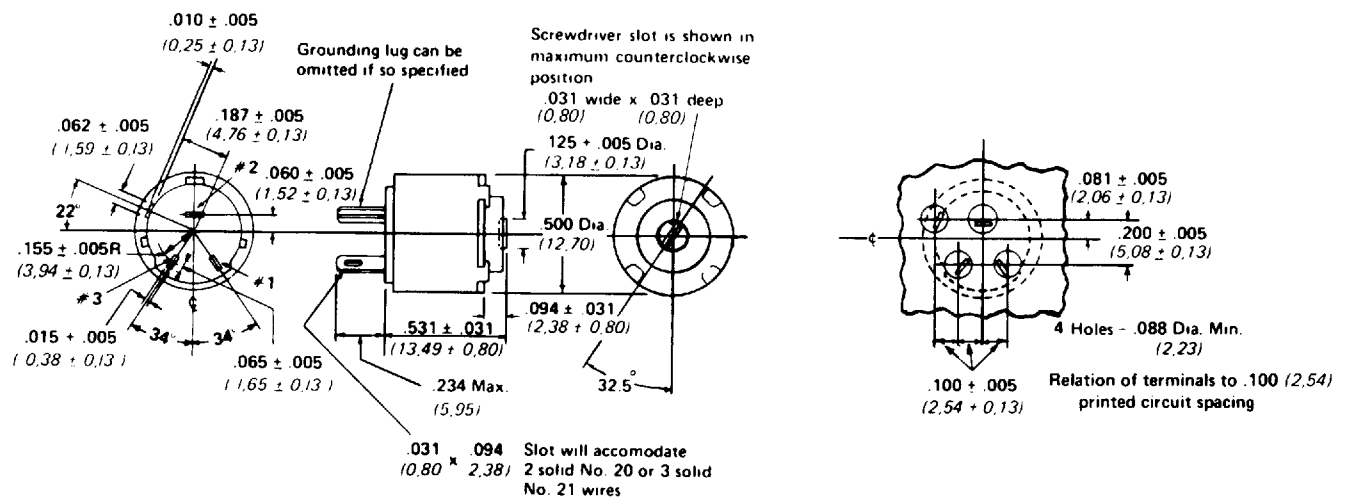

Resistor Connections

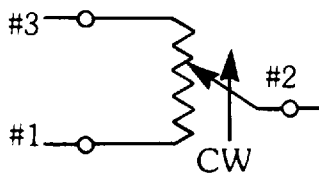

Basic dimensions in inches.
Dimensions shown in parentheses are in millimeters.
Terminal spacing determined at mounting surface.

TOLERANCES

Dimensional tolerance $\pm .016$ (0.40).

Angular tolerance $\pm 5^\circ$.

Except as specified.

NOT TO SCALE