



## REFERENCE ONLY

# 16-MBIT FlashFile™ MEMORY

28F016SV

*Includes Commercial and Extended Temperature Specifications*

- **SmartVoltage Technology**
  - User-Selectable 3.3 V or 5 V  $V_{CC}$
  - User-Selectable 5 V or 12 V  $V_{PP}$
- **65 ns Access Time**
- **1 Million Erase Cycles per Block**
- **30.8 MB/sec Burst Write Transfer Rate**
- **0.48 MB/sec Sustainable Write Transfer Rate**
- **Configurable x8 or x16 Operation**
- **56-Lead TSOP and SSOP Type I Packages**
- **Backwards-Compatible with 28F016SA, 28F008SA Command Set**
- **Revolutionary Architecture**
  - Multiple Command Execution
  - Program during Erase
  - Command Super-Set of the Intel 28F008SA
  - Page Buffer Program
- **2  $\mu$ A Typical Deep Power-Down**
- **32 Independently Lockable Blocks**
- **State-of-the-Art 0.6  $\mu$ m ETOX™ IV Flash Technology**

Intel's 28F016SV 16-Mbit FlashFile™ memory is a revolutionary architecture which is the ideal choice for designing embedded direct-execute code and mass storage data/file flash memory systems. With innovative capabilities, low-power operation, user-selectable  $V_{PP}$  voltage and high read/program performance, the 28F016SV enables the design of truly mobile, high-performance personal computing and communications products.

The 28F016SV is the highest density, highest performance nonvolatile read/program solution for solid-state storage applications. Its symmetrically-blocked architecture (100% compatible with the 28F008SA 8-Mbit and 28F016SA 16-Mbit FlashFile memories), extended cycling, flexible  $V_{CC}$  and  $V_{PP}$  voltage (SmartVoltage technology), fast program and read performance and selective block locking, provide a highly-flexible memory component suitable for Resident Flash Arrays, high-density memory cards and PCMCIA-ATA flash drives. The 28F016SV's dual read voltage enables the design of memory cards which can be read/written in 3.3 V and 5 V systems interchangeably. Its x8/x16 architecture allows optimization of the memory-to-processor interface. The flexible block locking option enables bundling of executable application software in a Resident Flash Array or memory card. The 28F016SV is manufactured on Intel's 0.6  $\mu$ m ETOX IV process technology.

### New Design Recommendations:

For new 3.3 V  $V_{CC}$  designs with this device, Intel recommends using the 16-Mbit word-wide FlashFile™ memory. Reference *Word-Wide FlashFile™ Memory Family 28F160S3, 28F320S3* datasheet, order number 290608. For new 3.3 V  $V_{CC}$  x8 I/O designs with this device, Intel recommends using the 16-Mbit Byte-Wide Smart 3 FlashFile™ memory. Reference *Byte-Wide Smart 3 FlashFile™ Memory Family* datasheet, order number 290598.

For new 5 V  $V_{CC}$  designs with this device, Intel recommends using the 16-Mbit word-wide FlashFile™ memory. Reference *Word-Wide FlashFile™ Memory Family 28F160S5, 28F320S5* datasheet, order number 290609. For new 5 V  $V_{CC}$  x8 I/O designs with this device, Intel recommends using the 16-Mbit Byte-Wide Smart 5 FlashFile™ memory. Reference *Byte-Wide Smart 5 FlashFile™ Memory Family* datasheet, order number 290597.

These documents are also available at Intel's website, <http://www.intel.com/design/flcomp>.

December 1997

Order Number: 290528-008



Information in this document is provided in connection with Intel products. No license, express or implied, by estoppel or otherwise, to any intellectual property rights is granted by this document. Except as provided in Intel's Terms and Conditions of Sale for such products, Intel assumes no liability whatsoever, and Intel disclaims any express or implied warranty, relating to sale and/or use of Intel products including liability or warranties relating to fitness for a particular purpose, merchantability, or infringement of any patent, copyright or other intellectual property right. Intel products are not intended for use in medical, life saving, or life sustaining applications.

Intel may make changes to specifications and product descriptions at any time, without notice.

The 28F016SV may contain design defects or errors known as errata which may cause the product to deviate from published specifications. Current characterized errata are available on request.

Contact your local Intel sales office or your distributor to obtain the latest specifications and before placing your product order.

Copies of documents which have an ordering number and are referenced in this document, or other Intel literature, may be obtained from:

Intel Corporation  
P.O. Box 5937  
Denver, CO 80217-9808

or call 1-800-548-4728  
or visit Intel's Website at <http://www.intel.com>



# CONTENTS

	PAGE		PAGE
<b>1.0 INTRODUCTION .....</b>	<b>7</b>	<b>5.0 ELECTRICAL SPECIFICATIONS.....</b>	<b>25</b>
1.1 Enhanced Features.....	7	5.1 Absolute Maximum Ratings.....	25
1.2 Product Overview.....	7	5.2 Capacitance .....	26
<b>2.0 DEVICE PINOUT.....</b>	<b>9</b>	5.3 DC Characteristics ( $V_{CC} = 3.3V \pm 0.3V$ ) .....	29
2.1 Lead Descriptions .....	11	5.4 DC Characteristics ( $V_{CC} = 5V \pm 0.5V$ ) 5V $\pm$ 0.25V) .....	33
<b>3.0 MEMORY MAPS .....</b>	<b>15</b>	5.5 Timing Nomenclature .....	37
3.1 Extended Status Registers Memory Map ...	16	5.6 AC Characteristics—Read Only Operations	38
<b>4.0 BUS OPERATIONS, COMMANDS AND STATUS REGISTER DEFINITIONS .....</b>	<b>17</b>	5.7 Power-Up and Reset Timings.....	43
4.1 Bus Operations for Word-Wide Mode (BYTE# = $V_{IH}$ ).....	17	5.8 AC Characteristics for WE#—Controlled Command Write Operations .....	44
4.2 Bus Operations for Byte-Wide Mode (BYTE# = $V_{IL}$ ).....	17	5.9 AC Characteristics for CE#—Controlled Command Write Operations).....	49
4.3 28F008SA—Compatible Mode Command Bus Definitions .....	18	5.10 AC Characteristics for WE#—Controlled Page Buffer Program Operations.....	54
4.4 28F016SV—Performance Enhancement Command Bus Definitions .....	19	5.11 AC Characteristics for CE#—Controlled Page Buffer Program Operations.....	56
4.5 Compatible Status Register.....	21	5.12 Erase and Word/Byte Program Performance.....	58
4.6 Global Status Register .....	22	<b>6.0 MECHANICAL SPECIFICATIONS.....</b>	<b>60</b>
4.7 Block Status Register.....	23	<b>7.0 Device Nomenclature and Ordering Information .....</b>	<b>61</b>
4.8 Device Configuration Code.....	24	<b>8.0 Additional Information.....</b>	<b>63</b>

SEE NEW DESIGN RECOMMENDATIONS

### REVISION HISTORY

Number	Description
-001	Original Version
-002	<p>Added 28F016SV-065/-070 at 5V <math>V_{CC}</math> and 28F016SV-075 at 3.3V <math>V_{CC}</math>.</p> <p>Improved burst write transfer rate to 30.8 MB/sec.</p> <p>Added 56-lead SSOP Type I packaging information.</p> <p>Changed <math>V_{PPLK}</math> from 2V to 1.5V.</p> <p>Increased <math>I_{CCR}</math> at 5V <math>V_{CC}</math> and 3.3V <math>V_{CC}</math>:</p> <ul style="list-style-type: none"> <li><math>I_{CCR1}</math> from 30 mA (typ)/35 mA (max) to 40 mA (typ)/50 mA (max) @ <math>V_{CC} = 3.3V</math></li> <li><math>I_{CCR2}</math> from 15 mA (typ)/20 mA (max) to 20 mA (typ)/30 mA (max) @ <math>V_{CC} = 3.3V</math></li> <li><math>I_{CCR1}</math> from 50 mA (typ)/60 mA (max) to 75 mA (typ)/95 mA (max) @ <math>V_{CC} = 5V</math></li> <li><math>I_{CCR2}</math> from 30 mA (typ)/35 mA (max) to 45 mA (typ)/55 mA (max) @ <math>V_{CC} = 5V</math></li> </ul> <p>Moved AC Characteristics for Extended Register Reads into separate table.</p> <p>Increased <math>V_{PP}</math> MAX from 13V to 14V.</p> <p>Added Erase Suspend Command Latency times to Section 5.12</p> <p>Modified Device Nomenclature Section to include SSOP package option and Ordering Information</p>
-003	<p>Changed definition of "NC." Removed "No internal connection to die" from description.</p> <p>Added "xx" to Upper Byte of Command (Data) Definition in Sections 4.3 and 4.4.</p> <p>Added Note to Sleep Command (Section 4.4) denoting that the chip must be de-selected in order for the power consumption in sleep mode to reach deep power-down levels.</p> <p>Modified parameters "V" and "I" of Section 5.1 to apply to "NC" pins.</p> <p>Increased <math>I_{PPR}</math> (<math>V_{PP}</math> Read Current) for <math>V_{PP} &gt; V_{CC}</math> to 200 <math>\mu A</math> at <math>V_{CC} = 3.3V</math> and <math>V_{CC} = 5V</math></p> <p>Changed <math>V_{CC} = 5V</math> DC Characteristics (Section 5.5) marked with Note 1 to indicate that these currents are specified for a CMOS rise/fall time (10% to 90%) of &lt;5 ns and a TTL rise/fall time of &lt;10 ns.</p> <p>Corrected the graphical representation of <math>t_{WHGL}</math> and <math>t_{EHGL}</math> in Figures 15 and 16.</p> <p>Increased Typical "Page Buffer Byte/Word Program Times" from 6.0 <math>\mu s</math> to 8.0 <math>\mu s</math> (Byte) and 12.1 <math>\mu s</math> to 16.0 <math>\mu s</math> (Word) @ <math>V_{CC} = 3.3V/5V</math> and <math>V_{PP} = 5V</math>:</p> <p>Increased Typ. "Byte/Word Program Times" (<math>t_{WHRH1A}/t_{WHRH1B}</math>) for <math>V_{PP} = 5V</math> (Section 5.12)</p> <ul style="list-style-type: none"> <li><math>t_{WHRH1A}</math> from 16.5 <math>\mu s</math> to 29.0 <math>\mu s</math> and <math>t_{WHRH1B}</math> from 24.0 <math>\mu s</math> to 35.0 <math>\mu s</math> at <math>V_{CC} = 3.3V</math></li> <li><math>t_{WHRH1A}</math> from 11.0 <math>\mu s</math> to 20.0 <math>\mu s</math> and <math>t_{WHRH1B}</math> from 16.0 <math>\mu s</math> to 25.0 <math>\mu s</math> at <math>V_{CC} = 5V</math></li> </ul> <p>Increased Typical "Block Program Times" (<math>t_{WHRH2}/t_{WHRH3}</math>) for <math>V_{PP} = 5V</math> (Section 5.12):</p> <ul style="list-style-type: none"> <li><math>t_{WHRH2}</math> from 1.1 sec to 1.9 sec and <math>t_{WHRH3}</math> from 0.8 sec to 1.2 sec at <math>V_{CC} = 3.3V</math></li> <li><math>t_{WHRH2}</math> from 0.8 sec to 1.4 sec and <math>t_{WHRH3}</math> from 0.6 sec to 0.85 sec at <math>V_{CC} = 5V</math></li> </ul> <p>Changed "Time from Erase Suspend Command to WSM Ready" spec name to "Erase Suspend Latency Time to Read;" modified typical values and added Min/Max values at <math>V_{CC} = 3.3/5V</math> and <math>V_{PP} = 5V/12V</math> (Section 5.12)</p> <p>Added "Erase Suspend Latency Time to Program" Specifications to Section 5.12</p> <p>Minor cosmetic changes throughout document</p>

**REVISION HISTORY** (Continued)

Number	Description
-004	<p>Added 3/5# pin to Block Diagram (Figure 1), Pinout Configurations (Figures 2 and 3), Product Overview (Section 1.1) and Lead Descriptions (Section 2.1)</p> <p>Added 3/5# pin to Test Conditions of I<sub>CCS</sub> Specifications</p> <p>Added 3/5# pin (Y) to Timing Nomenclature (Section 5.5)</p> <p>Increased t<sub>PHQV</sub> Specifications at 5V V<sub>CC</sub> to 400 ns for E28F016SV 065 devices and 480 ns for E28F106SV 070 devices.</p> <p>Modified Power-Up and Reset Timings (Section 5.9) to include 3/5# pin: Removed t<sub>5VPH</sub> and t<sub>3VPH</sub> specifications; Added t<sub>PLYL</sub>, t<sub>PLYH</sub>, t<sub>YLPH</sub>, and t<sub>YHPH</sub> specifications</p> <p>Added t<sub>PHEL3</sub> and t<sub>PHEL5</sub> specifications to Power-Up and Reset Timings (Section 5.9)</p> <p>Corrected TSOP Mechanical Specification A<sub>1</sub> from 0.50 mm to 0.050 mm (Section 6.0)</p> <p>Corrected SSOP Mechanical Spec. B (max) from 0.20 mm to 0.40 mm (Section 6.0)</p> <p>Minor cosmetic changes throughout document.</p>
-005	<p>Updated DC Specifications: I<sub>CCD</sub>, I<sub>PPES</sub></p> <p>Updated AC Specifications: Page Buffer Reads: (t<sub>AVAV</sub>, t<sub>AVQV</sub>, t<sub>ELQV</sub>, and t<sub>FLQV</sub>/t<sub>FHQV</sub>)</p> <p>Page Buffer WE#-Controlled Command Writes (t<sub>ELWL</sub>)</p> <p>CE#-Controlled Command Write Parameters (t<sub>AVAV</sub>, t<sub>ELEH</sub>, t<sub>EHEL</sub>)</p> <p>Combined Commercial and Extended Temperature information into single datasheet.</p>
-006	<p>Updated AC Specifications: Page Buffer Reads: (t<sub>AVAV</sub>, t<sub>AVQV</sub>, t<sub>ELQV</sub>, and t<sub>FLQV</sub>/t<sub>FHQV</sub>)</p>
-007	<p>Updated Disclaimer</p>
-008	<p>Added <i>New Design Recommendations</i> section to cover page</p>

**SEE NEW DESIGN RECOMMENDATIONS**



Page intentionally left blank



## 1.0 INTRODUCTION

The documentation of the Intel 28F016SV memory device includes this datasheet, a detailed user's manual, and a number of application notes and design tools, all of which are referenced in Section 8.0.

The datasheet is intended to give an overview of the chip feature-set and of the operating AC/DC specifications. The *16-Mbit Flash Product Family User's Manual* provides complete descriptions of the user modes, system interface examples and detailed descriptions of all principles of operation. It also contains the full list of software algorithm flowcharts, and a brief section on compatibility with the Intel 28F008SA.

A significant 28F016SV change occurred between datasheet revisions 290528-003 and 290528-004. This change centers around the addition of a 3/5# pin to the device's pinout configuration. Figures 2 and 3 show the 3/5# pin assignment for TSOP and SSOP Type 1 packages. Intel recommends that all customers obtain the latest revisions of 28F016SV documentation.

### 1.1 Enhanced Features

The 28F016SV is backwards compatible with the 28F016SA and offers the following enhancements:

- SmartVoltage Technology
  - Selectable 5V or 12V  $V_{PP}$
- $V_{PP}$  Level Bit in Block Status Register
- Additional RY/BY# Configuration
  - Pulse-On-Program/Erase
- Additional Upload Device Information Command Feedback
  - Device Proliferation Code
  - Device Configuration Code

### 1.2 Product Overview

The 28F016SV is a high-performance, 16-Mbit (16,777,216-bit) block erasable, nonvolatile random access memory, organized as either 1 Mword x 16 or 2 Mbyte x 8. The 28F016SV includes thirty-two 64-KB (65,536 byte) blocks or thirty-two 32-KW (32,768 word) blocks. A chip memory map is shown in Figure 4.

The implementation of a new architecture, with many enhanced features, will improve the device operating characteristics and result in greater product reliability and ease-of-use.

The 28F016SV incorporates SmartVoltage technology, providing  $V_{CC}$  operation at both 3.3V and 5V and program and erase capability at  $V_{PP} = 12V$  or 5V. Operating at  $V_{CC} = 3.3V$ , the 28F016SV consumes approximately one half the power consumption at 5V  $V_{CC}$ , while 5V  $V_{CC}$  provides the highest read performance capability.  $V_{PP} = 5V$  operation eliminates the need for a separate 12V converter, while  $V_{PP} = 12V$  maximizes program/erase performance. In addition to the flexible program and erase voltages, the dedicated  $V_{PP}$  gives complete code protection with  $V_{PP} \leq V_{PPLK}$ .

A 3/5# input pin configures the device's internal circuitry for optimal 3.3V or 5V read/program operation.

A Command User Interface (CUI) serves as the system interface between the microprocessor or microcontroller and the internal memory operation.

Internal Algorithm Automation allows byte/word programs and block erase operations to be executed using a Two-Program command sequence to the CUI in the same way as the 28F008SA 8-Mbit FlashFile™ memory.

A super-set of commands has been added to the basic 28F008SA command-set to achieve higher program performance and provide additional capabilities. These new commands and features include:

- Page Buffer Programs to Flash
- Command Queuing Capability
- Automatic Data Programs during Erase
- Software Locking of Memory Blocks
- Two-Byte Successive Programs in 8-bit Systems
- Erase All Unlocked Blocks

Writing of memory data is performed in either byte or word increments typically within 6  $\mu$ s (12V  $V_{PP}$ )—a 33% improvement over the 28F008SA. A block erase operation erases one of the 32 blocks in typically 0.6 sec (12V  $V_{PP}$ ), independent of the other blocks, which is about a 65% improvement over the 28F008SA.

## 28F016SV FlashFile™ MEMORY



Each block can be written and erased a minimum of 100,000 cycles. Systems can achieve one million Block Erase Cycles by providing wear-leveling algorithms and graceful block retirement. These techniques have already been employed in many flash file systems and hard disk drive designs.

The 28F016SV incorporates two Page Buffers of 256 bytes (128 words) each to allow page data programs. This feature can improve a system program performance by up to 4.8 times over previous flash memory devices, which have no Page Buffers.

All operations are started by a sequence of Program commands to the device. Three Status Registers (described in detail later in this datasheet) and a RY/BY# output pin provide information on the progress of the requested operation.

While the 28F008SA requires an operation to complete before the next operation can be requested, the 28F016SV allows queuing of the next operation while the memory executes the current operation. This eliminates system overhead when writing several bytes in a row to the array or erasing several blocks at the same time. The 28F016SV can also perform program operations to one block of memory while performing erase of another block.

The 28F016SV provides selectable block locking to protect code or data such as Device Drivers, PCMCIA card information, ROM-Executable O/S or Application Code. Each block has an associated nonvolatile lock-bit which determines the lock status of the block. In addition, the 28F016SV has a master Write Protect pin (WP#) which prevents any modifications to memory blocks whose lock-bits are set.

The 28F016SV contains three types of Status Registers to accomplish various functions:

- A Compatible Status Register (CSR) which is 100% compatible with the 28F008SA FlashFile memory Status Register. The CSR, when used alone, provides a straightforward upgrade capability to the 28F016SV from a 28F008SA-based design.
- A Global Status Register (GSR) which informs the system of command Queue status, Page Buffer status, and overall Write State Machine (WSM) status.

- 32 Block Status Registers (BSRs) which provide block-specific status information such as the block lock-bit status.

The GSR and BSR memory maps for byte-wide and word-wide modes are shown in Figures 5 and 6.

The 28F016SV incorporates an open drain RY/BY# output pin. This feature allows the user to OR-tie many RY/BY# pins together in a multiple memory configuration such as a Resident Flash Array.

Other configurations of the RY/BY# pin are enabled via special CUI commands and are described in detail in the *16-Mbit Flash Product Family User's Manual*.

The 28F016SV's enhanced Upload Device Information command provides access to additional information that the 28F016SA previously did not offer. This command uploads the Device Revision Number, Device Proliferation Code and Device Configuration Code to the page buffer. The Device Proliferation Code for the 28F016SV is 01H, and the Device Configuration Code identifies the current RY/BY# configuration. Section 4.4 documents the exact page buffer address locations for all uploaded information. A subsequent Page Buffer Swap and Page Buffer Read command sequence is necessary to read the correct device information.

The 28F016SV also incorporates a dual chip-enable function with two input pins, CE<sub>0</sub># and CE<sub>1</sub>#. These pins have exactly the same functionality as the regular chip-enable pin, CE#, on the 28F008SA. For minimum chip designs, CE<sub>1</sub># may be tied to ground and system logic may use CE<sub>0</sub># as the chip enable input. The 28F016SV uses the logical combination of these two signals to enable or disable the entire chip. Both CE<sub>0</sub># and CE<sub>1</sub># must be active low to enable the device. If either one becomes inactive, the chip will be disabled. This feature, along with the open drain RY/BY# pin, allows the system designer to reduce the number of control pins used in a large array of 16-Mbit devices.

The BYTE# pin allows either x8 or x16 read/programs to the 28F016SV. BYTE# at logic low selects 8-bit mode with address A<sub>0</sub> selecting between the low byte and high byte. On the other hand, BYTE# at logic high enables 16-bit operation with address A<sub>1</sub> becoming the lowest



order address and address  $A_0$  is not used (don't care). A device block diagram is shown in Figure 1.

The 28F016SV is specified for a maximum access time of 65 ns ( $t_{ACC}$ ) at 5V operation (4.75V to 5.25V) over the commercial temperature range (0°C to +70°C). A corresponding maximum access time of 75 ns at 3.3V (3.0V to 3.6V and 0°C to +70°C) is achieved for reduced power consumption applications.

The 28F016SV incorporates an Automatic Power Saving (APS) feature, which substantially reduces the active current when the device is in static mode of operation (addresses not switching). In APS mode, the typical  $I_{CC}$  current is 1 mA at 5V (3.0 mA at 3.3V).

A deep power-down mode of operation is invoked when the RP# (called PWD# on the 28F008SA) pin transitions low. This mode brings the device power consumption to less than 2.0  $\mu$ A, typically, and provides additional program protection by acting as a device reset pin during power transitions. A reset time of 400 ns (5V  $V_{CC}$

operation) is required from RP# switching high until outputs are again valid. In the Deep Power-Down state, the WSM is reset (any current operation will abort) and the CSR, GSR and BSR registers are cleared.

A CMOS standby mode of operation is enabled when either  $CE_0\#$  or  $CE_1\#$  transitions high and RP# stays high with all input control pins at CMOS levels. In this mode, the device typically draws an  $I_{CC}$  standby current of 70  $\mu$ A at 5V  $V_{CC}$ .

The 28F016SV will be available in 56-lead, 1.2 mm thick, 14 mm x 20 mm TSOP and 56-lead, 1.8 mm thick, 16 mm x 23.7 SSOP Type I packages. The form factor and pinout of these two packages allow for very high board layout densities.

## 2.0 DEVICE PINOUT

The 28F016SV 56-lead TSOP and 56-lead SSOP Type I pinout configurations are shown in Figures 2 and 3.

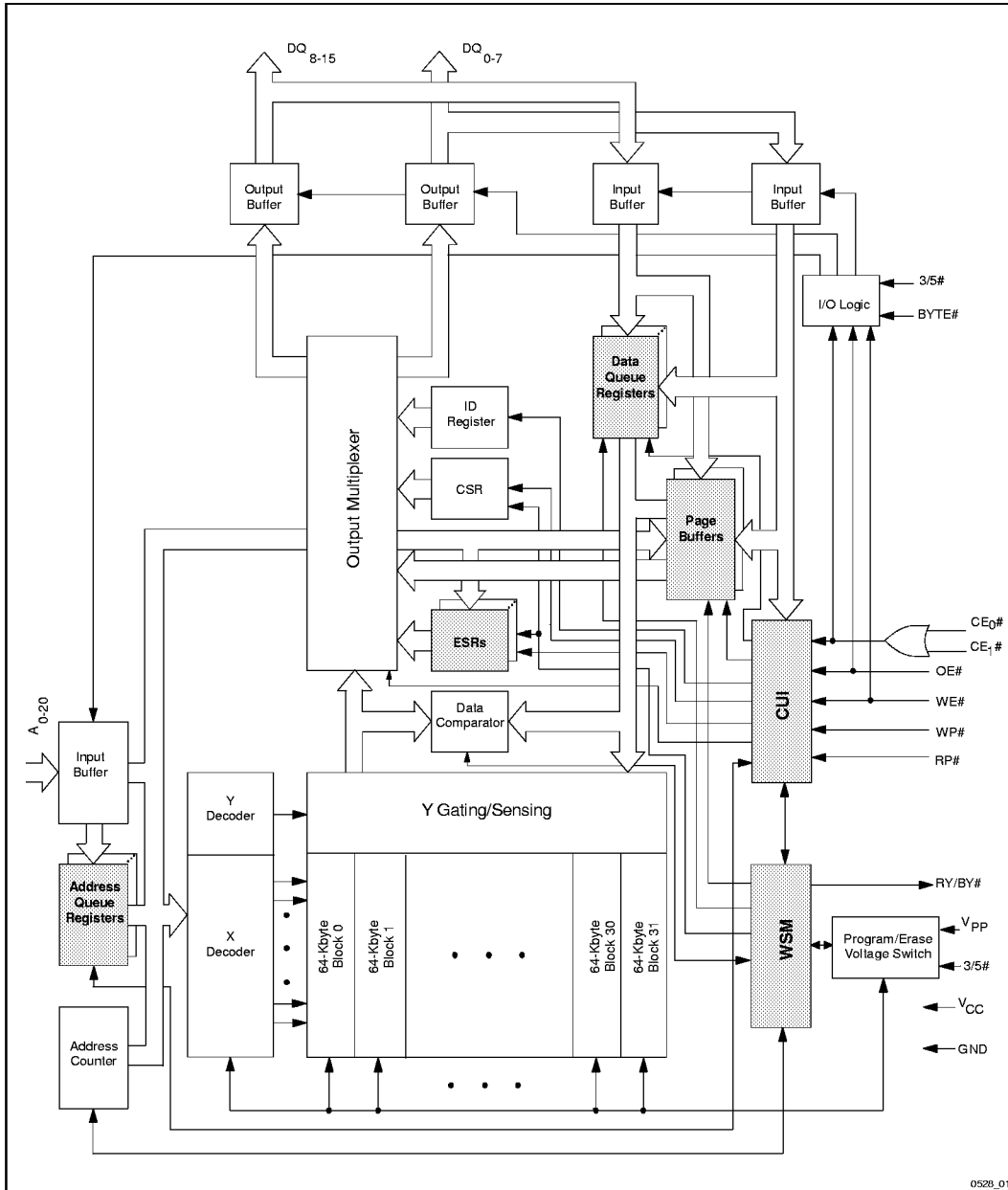

**Figure 1. 28F016SV Block Diagram**  
**Architectural Evolution Includes SmartVoltage Technology,**  
**Page Buffers, Queue Registers and Extended Registers**

**2.1 Lead Descriptions**

Symbol	Type	Name and Function
A <sub>0</sub>	INPUT	<b>BYTE-SELECT ADDRESS:</b> Selects between high and low byte when device is in x8 mode. This address is latched in x8 data programs. Not used in x16 mode (i.e., the A <sub>0</sub> input buffer is turned off when BYTE# is high).
A <sub>1</sub> –A <sub>15</sub>	INPUT	<b>WORD-SELECT ADDRESSES:</b> Select a word within one 64-Kbyte block. A <sub>6</sub> –A <sub>15</sub> selects 1 of 1024 rows, and A <sub>1</sub> –A <sub>5</sub> selects 16 of 512 columns. These addresses are latched during data programs.
A <sub>16</sub> –A <sub>20</sub>	INPUT	<b>BLOCK-SELECT ADDRESSES:</b> Select 1 of 32 Erase blocks. These addresses are latched during data programs, erase and lock block operations.
DQ <sub>0</sub> –DQ <sub>7</sub>	INPUT/OUTPUT	<b>LOW-BYTE DATA BUS:</b> Inputs data and commands during CUI program cycles. Outputs array, buffer, identifier or status data in the appropriate read mode. Floated when the chip is de-selected or the outputs are disabled.
DQ <sub>8</sub> –DQ <sub>15</sub>	INPUT/OUTPUT	<b>HIGH-BYTE DATA BUS:</b> Inputs data during x16 data program operations. Outputs array, buffer or identifier data in the appropriate read mode; not used for Status Register reads. Floated when the chip is de-selected or the outputs are disabled.
CE <sub>0</sub> #, CE <sub>1</sub> #	INPUT	<b>CHIP ENABLE INPUTS:</b> Activate the device's control logic, input buffers, decoders and sense amplifiers. With either CE <sub>0</sub> # or CE <sub>1</sub> # high, the device is de-selected and power consumption reduces to standby levels upon completion of any current data program or erase operations. Both CE <sub>0</sub> # and CE <sub>1</sub> # must be low to select the device. All timing specifications are the same for both signals. Device Selection occurs with the latter falling edge of CE <sub>0</sub> # or CE <sub>1</sub> #. The first rising edge of CE <sub>0</sub> # or CE <sub>1</sub> # disables the device.
RP#	INPUT	<b>RESET/POWER-DOWN:</b> RP# low places the device in a deep power-down state. All circuits that consume static power, even those circuits enabled in standby mode, are turned off. When returning from deep power-down, a recovery time of t <sub>PHQV</sub> is required to allow these circuits to power-up. When RP# goes low, any current or pending WSM operation(s) are terminated, and the device is reset. All Status Registers return to ready (with all status flags cleared). Exit from deep power-down places the device in read array mode.
OE#	INPUT	<b>OUTPUT ENABLE:</b> Gates device data through the output buffers when low. The outputs float to tri-state off when OE# is high. <b>NOTE:</b> CE <sub>x</sub> # overrides OE#, and OE# overrides WE#.
WE#	INPUT	<b>WRITE ENABLE:</b> Controls access to the CUI, Page Buffers, Data Queue Registers and Address Queue Latches. WE# is active low, and latches both address and data (command or array) on its rising edge. Page Buffer addresses are latched on the falling edge of WE#.

## 2.1 Lead Descriptions (Continued)

Symbol	Type	Name and Function
RY/BY#	OPEN DRAIN OUTPUT	<b>READY/BUSY:</b> Indicates status of the internal WSM. When low, it indicates that the WSM is busy performing an operation. RY/BY# floating indicates that the WSM is ready for new operations (or WSM has completed all pending operations), or erase is suspended, or the device is in deep power-down mode. This output is always active (i.e., not floated to tri-state off when OE# or CE <sub>0</sub> #, CE <sub>1</sub> # are high), except if a RY/BY# Pin Disable command is issued.
WP#	INPUT	<b>WRITE PROTECT:</b> Erase blocks can be locked by writing a nonvolatile lock-bit for each block. When WP# is low, those locked blocks as reflected by the Block-Lock Status bits (BSR.6), are protected from inadvertent data programs or erases. When WP# is high, all blocks can be written or erased regardless of the state of the lock-bits. The WP# input buffer is disabled when RP# transitions low (deep power-down mode).
BYTE#	INPUT	<b>BYTE ENABLE:</b> BYTE# low places device in x8 mode. All data is then input or output on DQ <sub>0-7</sub> , and DQ <sub>8-15</sub> float. Address A <sub>0</sub> selects between the high and low byte. BYTE# high places the device in x16 mode, and turns off the A <sub>0</sub> input buffer. Address A <sub>1</sub> , then becomes the lowest order address.
3/5#	INPUT	<b>3.3/5.0 VOLT SELECT:</b> 3/5# high configures internal circuits for 3.3V operation. 3/5# low configures internal circuits for 5V operation. <b>NOTE:</b> Reading the array with 3/5# high in a 5V system could damage the device. Reference the power-up and reset timings (Section 5.7) for 3/5# switching delay to valid data.
V <sub>PP</sub>	SUPPLY	<b>PROGRAM/ERASE POWER SUPPLY (12V ± 0.6V, 5V ± 0.5V) :</b> For erasing memory array blocks or writing words/bytes/pages into the flash array. V <sub>PP</sub> = 5V ± 0.5V eliminates the need for a 12V converter, while connection to 12V ± 0.6V maximizes Program/Erase Performance. <b>NOTE:</b> Successful completion of program and erase attempts is inhibited with V <sub>PP</sub> at or below 1.5V. Program and erase attempts with V <sub>PP</sub> between 1.5V and 4.5V, between 5.5V and 11.4V, and above 12.6V produce spurious results and should not be attempted.
V <sub>CC</sub>	SUPPLY	<b>DEVICE POWER SUPPLY (3.3V ± 0.3V, 5V ± 0.5V, 5.0 ± 0.25V):</b> To switch 3.3V to 5V (or vice versa), first ramp V <sub>CC</sub> down to GND, and then power to the new V <sub>CC</sub> voltage. Do not leave any power pins floating.
GND	SUPPLY	<b>GROUND FOR ALL INTERNAL CIRCUITRY:</b> Do not leave any ground pins floating.
NC		<b>NO CONNECT:</b> Lead may be driven or left floating.

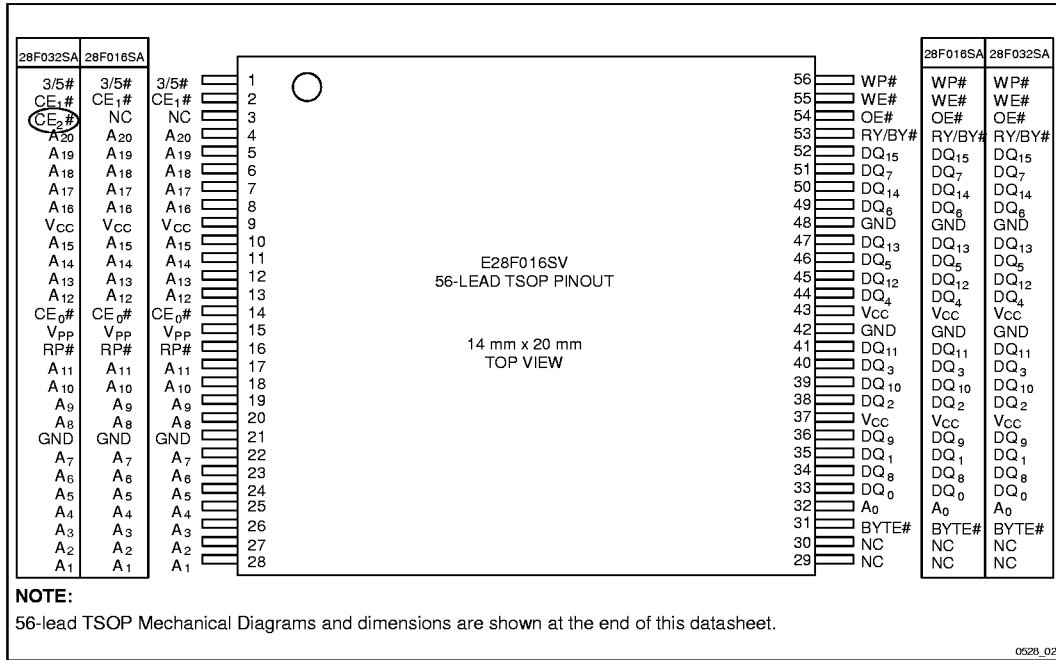

**Figure 2. 28F016SV 56-Lead TSOP Pinout Configuration Shows Compatibility with 28F016SA/28F032SA**

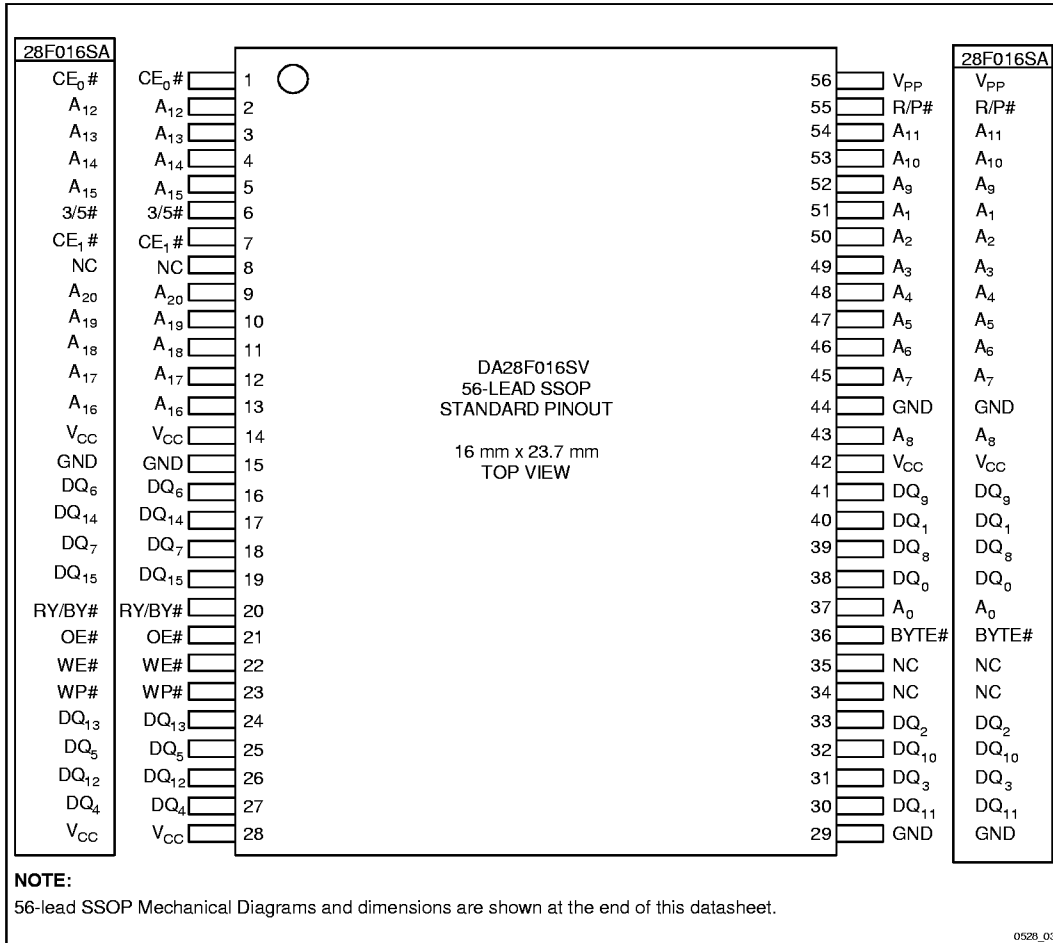
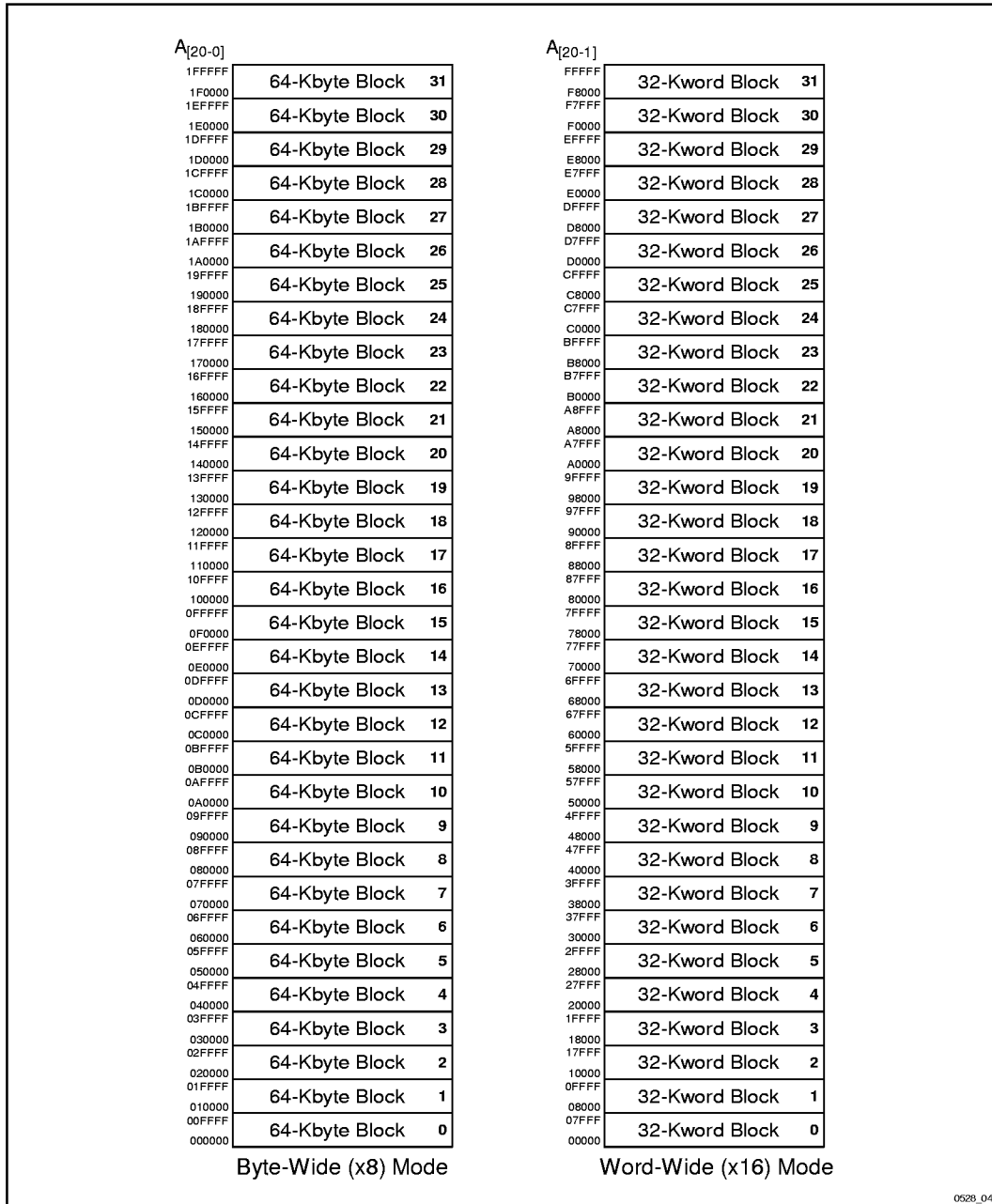

Figure 3. 56-Lead SSOP Pinout Configuration

3.0 MEMORY MAPS



0529\_04

Figure 4. 28F016SV Memory Maps (Byte-Wide and Word-Wide Modes)

SEE NEW DESIGN RECOMMENDATIONS

### 3.1 Extended Status Registers Memory Map

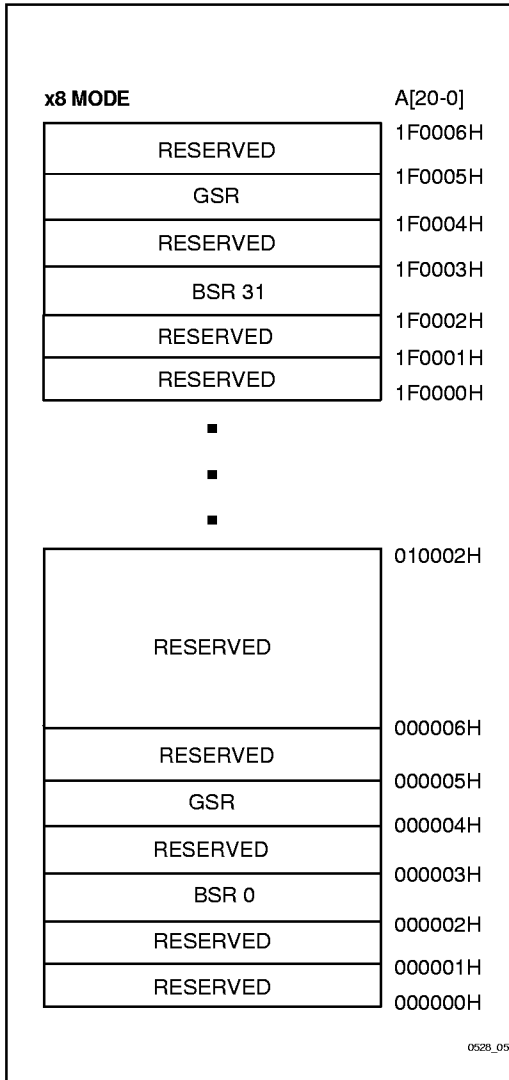

Figure 5. Extended Status Register Memory Map (Byte-Wide Mode)

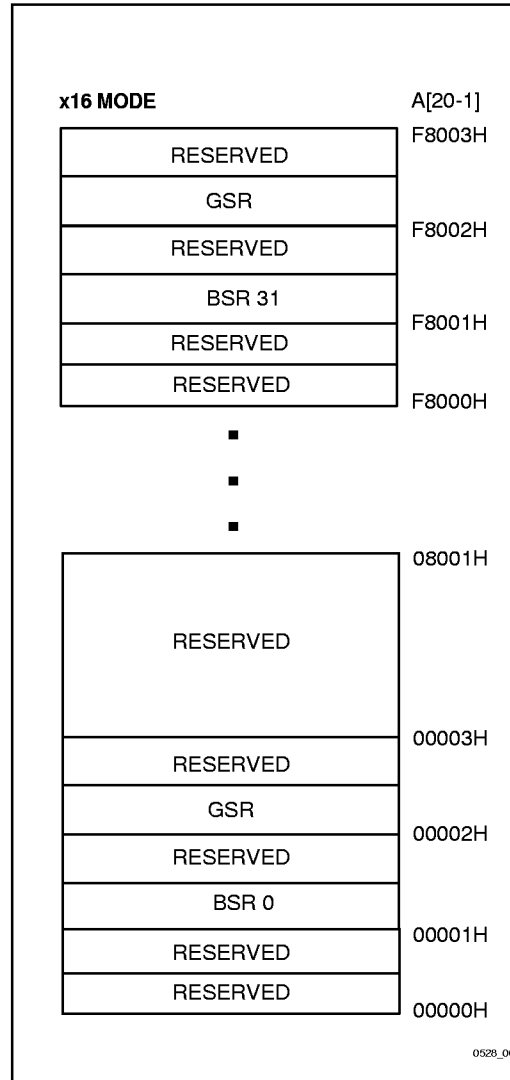

Figure 6. Extended Status Register Memory Map (Word-Wide Mode)

## 4.0 BUS OPERATIONS, COMMANDS AND STATUS REGISTER DEFINITIONS

### 4.1 Bus Operations for Word-Wide Mode (BYTE# = V<sub>IH</sub>)

Mode	Notes	RP#	CE <sub>1</sub> #	CE <sub>0</sub> #	OE#	WE#	A <sub>1</sub>	DQ <sub>0-15</sub>	RY/BY#
Read	1,2,7	V <sub>IH</sub>	V <sub>IL</sub>	V <sub>IL</sub>	V <sub>IL</sub>	V <sub>IH</sub>	X	D <sub>OUT</sub>	X
Output Disable	1,6,7	V <sub>IH</sub>	V <sub>IL</sub>	V <sub>IL</sub>	V <sub>IH</sub>	V <sub>IH</sub>	X	High Z	X
Standby	1,6,7	V <sub>IH</sub>	V <sub>IL</sub> V <sub>IH</sub> V <sub>IH</sub>	V <sub>IH</sub> V <sub>IL</sub> V <sub>IH</sub>	X	X	X	High Z	X
Deep Power-Down	1,3	V <sub>IL</sub>	X	X	X	X	X	High Z	V <sub>OH</sub>
Manufacturer ID	4	V <sub>IH</sub>	V <sub>IL</sub>	V <sub>IL</sub>	V <sub>IL</sub>	V <sub>IH</sub>	V <sub>IL</sub>	0089H	V <sub>OH</sub>
Device ID	4,8	V <sub>IH</sub>	V <sub>IL</sub>	V <sub>IL</sub>	V <sub>IL</sub>	V <sub>IH</sub>	V <sub>IH</sub>	66A0H	V <sub>OH</sub>
Write	1,5,6	V <sub>IH</sub>	V <sub>IL</sub>	V <sub>IL</sub>	V <sub>IH</sub>	V <sub>IL</sub>	X	D <sub>IN</sub>	X

### 4.2 Bus Operations for Byte-Wide Mode (BYTE# = V<sub>IL</sub>)

Mode	Notes	RP#	CE <sub>1</sub> #	CE <sub>0</sub> #	OE#	WE#	A <sub>0</sub>	DQ <sub>0-7</sub>	RY/BY#
Read	1,2,7	V <sub>IH</sub>	V <sub>IL</sub>	V <sub>IL</sub>	V <sub>IL</sub>	V <sub>IH</sub>	X	D <sub>OUT</sub>	X
Output Disable	1,6,7	V <sub>IH</sub>	V <sub>IL</sub>	V <sub>IL</sub>	V <sub>IH</sub>	V <sub>IH</sub>	X	High Z	X
Standby	1,6,7	V <sub>IH</sub>	V <sub>IL</sub> V <sub>IH</sub> V <sub>IH</sub>	V <sub>IH</sub> V <sub>IL</sub> V <sub>IH</sub>	X	X	X	High Z	X
Deep Power-Down	1,3	V <sub>IL</sub>	X	X	X	X	X	High Z	V <sub>OH</sub>
Manufacturer ID	4	V <sub>IH</sub>	V <sub>IL</sub>	V <sub>IL</sub>	V <sub>IL</sub>	V <sub>IH</sub>	V <sub>IL</sub>	89H	V <sub>OH</sub>
Device ID	4,8	V <sub>IH</sub>	V <sub>IL</sub>	V <sub>IL</sub>	V <sub>IL</sub>	V <sub>IH</sub>	V <sub>IH</sub>	A0H	V <sub>OH</sub>
Write	1,5,6	V <sub>IH</sub>	V <sub>IL</sub>	V <sub>IL</sub>	V <sub>IH</sub>	V <sub>IL</sub>	X	D <sub>IN</sub>	X

#### NOTES:

- X can be V<sub>IH</sub> or V<sub>IL</sub> for address or control pins except for RY/BY#, which is either V<sub>OL</sub> or V<sub>OH</sub>.
- RY/BY# output is open drain. When the WSM is ready, Erase is suspended or the device is in deep power-down mode. RY/BY# will be at V<sub>OH</sub> if it is tied to V<sub>CC</sub> through a resistor. RY/BY# at V<sub>OH</sub> is independent of OE# while a WSM operation is in progress.
- RP# at GND ± 0.2V ensures the lowest deep power-down current.
- A<sub>0</sub> and A<sub>1</sub> at V<sub>IL</sub> provide device manufacturer codes in x8 and x16 modes respectively. A<sub>0</sub> and A<sub>1</sub> at V<sub>IH</sub> provide device ID codes in x8 and x16 modes respectively. All other addresses are set to zero.
- Commands for erase, data program, or lock-block operations can only be completed successfully when V<sub>PP</sub> = V<sub>PPH1</sub> or V<sub>PP</sub> = V<sub>PPH2</sub>.
- While the WSM is running, RY/BY# in level-mode (default) stays at V<sub>OL</sub> until all operations are complete. RY/BY# goes to V<sub>OH</sub> when the WSM is not busy or in erase suspend mode.
- RY/BY# may be at V<sub>OL</sub> while the WSM is busy performing various operations (for example, a Status Register read during a program operation).
- The 28F016SV shares an identical device identifier (66A0H in word-wide mode, A0H in byte-wide mode) with the 28F016SA. See application note *AP-393 28F016SV Compatibility with 28F016SA* for software and hardware techniques to differentiate between the 28F016SV and 28F016SA.

**SEE NEW DESIGN RECOMMENDATIONS**

### 4.3 28F008SA—Compatible Mode Command Bus Definitions

Command	Notes	First Bus Cycle			Second Bus Cycle		
		Oper	Addr	Data <sup>(4)</sup>	Oper	Addr	Data <sup>(4)</sup>
Read Array		Write	X	xxFFH	Read	AA	AD
Intelligent Identifier	1	Write	X	xx90H	Read	IA	ID
Read Compatible Status Register	2	Write	X	xx70H	Read	X	CSRD
Clear Status Register	3	Write	X	xx50H			
Word/Byte Program		Write	X	xx40H	Write	PA	PD
Alternate Word/Byte Program		Write	X	xx10H	Write	PA	PD
Block Erase/Confirm		Write	X	xx20H	Write	BA	xxD0H
Erase Suspend/Resume		Write	X	xxB0H	Write	X	xxD0H

#### ADDRESS

AA = Array Address  
 BA = Block Address  
 IA = Identifier Address  
 PA = Program Address  
 X = Don't Care

#### DATA

AD = Array Data  
 CSRD = CSR Data  
 ID = Identifier Data  
 PD = Program Data

#### NOTES:

- Following the Intelligent Identifier command, two Read operations access the manufacturer and device signature codes.
- The CSR is automatically available after device enters data program, erase, or suspend operations.
- Clears CSR.3, CSR.4 and CSR.5. Also clears GSR.5 and all BSR.5, BSR.4 and BSR.2 bits. See Status Register definitions.
- The upper byte of the data bus (DQ<sub>8-15</sub>) during command writes is a "Don't Care" in x16 operation of the device.



#### 4.4 28F016SV—Performance Enhancement Command Bus Definitions

Command	Mode	Notes	First Bus Cycle			Second Bus Cycle			Third Bus Cycle		
			Oper	Addr	Data <sup>(13)</sup>	Oper	Addr	Data <sup>(13)</sup>	Oper	Addr	Data
Read Extended Status Register		1	Write	X	xx71H	Read	RA	GSRD BSRD			
Page Buffer Swap		7	Write	X	xx72H						
Read Page Buffer			Write	X	xx75H	Read	PBA	PD			
Single Load to Page Buffer			Write	X	xx74H	Write	PBA	PD			
Sequential Load to Page Buffer	x8	4,6,10	Write	X	xxE0H	Write	X	BCL	Write	X	BCH
	x16	4,5,6,10	Write	X	xxE0H	Write	X	WCL	Write	X	WCH
Page Buffer Write to Flash	x8	3,4,9,10	Write	X	xx0CH	Write	A0	BC(L,H)	Write	PA	BC(H,L)
	x16	4,5,10	Write	X	xx0CH	Write	X	WCL	Write	PA	WCH
Two-Byte Program	x8	3	Write	X	xxFBH	Write	A0	WD(L,H)	Write	PA	WD(H,L)
Lock Block/Confirm			Write	X	xx77H	Write	BA	xxD0H			
Upload Status Bits/Confirm		2	Write	X	xx97H	Write	X	xxD0H			
Upload Device Information/Confirm		11	Write	X	xx99H	Write	X	xxD0H			
Erase All Unlocked Blocks/Confirm			Write	X	xxA7H	Write	X	xxD0H			
RY/BY# Enable to Level-Mode		8	Write	X	xx96H	Write	X	xx01H			
RY/BY# Pulse-On-Write		8	Write	X	xx96H	Write	X	xx02H			
RY/BY# Pulse-On-Erase		8	Write	X	xx96H	Write	X	xx03H			
RY/BY# Disable		8	Write	X	xx96H	Write	X	xx04H			
RY/BY# Pulse-On-Write/Erase		8	Write	X	xx96H	Write	X	xx05H			
Sleep		12	Write	X	xxF0H						
Abort			Write	X	xx80H						

**ADDRESS**

BA = Block Address  
 PBA = Page Buffer Address  
 RA = Extended Register Address  
 PA = Program Address  
 X = Don't Care

**DATA**

AD = Array Data  
 PD = Page Buffer Data  
 BSRD = BSR Data  
 GSRD = GSR Data

WC (L,H) = Word Count (Low, High)  
 BC (L,H) = Byte Count (Low, High)  
 WD (L,H) = Write Data (Low, High)

**SEE NEW DESIGN RECOMMENDATIONS**

**NOTES:**

1. RA can be the GSR address or any BSR address. See Figures 4 and 5 for Extended Status Register memory maps.
2. Upon device power-up, all BSR lock-bits come up locked. The Upload Status Bits command must be written to reflect the actual lock-bit status.
3. A<sub>0</sub> is automatically complemented to load second byte of data. BYTE# must be at V<sub>IL</sub>. A<sub>0</sub> value determines which WD/BC is supplied first: A<sub>0</sub> = 0 looks at the WDL/BCL, A<sub>0</sub> = 1 looks at the WDH/BCH.
4. BCH/WCH must be at 00H for this product because of the 256-byte (128-word) Page Buffer size, and to avoid writing the Page Buffer contents to more than one 256-byte segment within an array block. They are simply shown for future Page Buffer expandability.
5. In x16 mode, only the lower byte DQ<sub>0-7</sub> is used for WCL and WCH. The upper byte DQ<sub>8-15</sub> is a don't care.
6. PBA and PD (whose count is given in cycles 2 and 3) are supplied starting in the fourth cycle, which is not shown.
7. This command allows the user to swap between available Page Buffers (0 or 1).
8. These commands reconfigure RY/BY# output to one of three pulse-modes or enable and disable the RY/BY# function.
9. Program address, PA, is the Destination address in the flash array which must match the Source address in the Page Buffer. Refer to the *16-Mbit Flash Product Family User's Manual*.
10. BCL = 00H corresponds to a byte count of 1. Similarly, WCL = 00H corresponds to a word count of 1.
11. After writing the Upload Device Information command and the Confirm command, the following information is output at Page Buffer addresses specified below:

Address	Information
06H, 07H (Byte Mode)	Device Revision Number
03H (Word Mode)	Device Revision Number
1EH (Byte Mode)	Device Configuration Code
0FH (DQ <sub>0-7</sub> )(Word Mode)	Device Configuration Code
1FH (Byte Mode)	Device Proliferation Code (01H)
0FH (DQ <sub>8-15</sub> )(Word Mode)	Device Proliferation Code (01H)

A page buffer swap followed by a page buffer read sequence is necessary to access this information. The contents of all other Page Buffer locations, after the Upload Device Information command is written, are reserved for future implementation by Intel Corporation. See Section 4.8 for a description of the Device Configuration Code. This code also corresponds to data written to the 28F016SV after writing the RY/BY# Reconfiguration command.

12. To ensure that the 28F016SV's power consumption during sleep mode reaches the deep power-down current level, the system also needs to de-select the chip by taking either or both CE<sub>0</sub># or CE<sub>1</sub># high.
13. The upper byte of the data bus (DQ<sub>8-15</sub>) during command writes is a "Don't Care" in x16 operation of the device.

**4.5 Compatible Status Register**

WSMS	ESS	ES	DWS	VPPS	R	R	R
7	6	5	4	3	2	1	0

<b>NOTES:</b>	
<p>CSR.7 = WRITE STATE MACHINE STATUS            1 = Ready            0 = Busy</p>	<p>RY/BY# output or WSMS bit must be checked to determine completion of an operation (erase, erase suspend, or data program) before the appropriate Status bit (ESS, ES or DWS) is checked for success.</p>
<p>CSR.6 = ERASE-SUSPEND STATUS            1 = Erase Suspended            0 = Erase in Progress/Completed</p>	
<p>CSR.5 = ERASE STATUS            1 = Error in Block Erasure            0 = Successful Block Erase</p>	<p>If DWS and ES are set to "1" during an erase attempt, an improper command sequence was entered. Clear the CSR and attempt the operation again.</p>
<p>CSR.4 = DATA-WRITE STATUS            1 = Error in Data Program            0 = Data Program Successful</p>	
<p>CSR.3 = V<sub>PP</sub> STATUS            1 = V<sub>PP</sub> Error Detect, Operation Abort            0 = V<sub>PP</sub> OK</p>	<p>The VPPS bit, unlike an A/D converter, does not provide continuous indication of V<sub>PP</sub> level. The WSM interrogates V<sub>PP</sub>'s level only after the Data Program or Erase command sequences have been entered, and informs the system if V<sub>PP</sub> has not been switched on. VPPS is not guaranteed to report accurate feedback between V<sub>PPLK</sub>(max) and V<sub>PPH1</sub>(min), between V<sub>PPH1</sub>(max) and V<sub>PPH2</sub>(min) and above V<sub>PPH2</sub>(max).</p>
<p>CSR.2-0 = RESERVED FOR FUTURE ENHANCEMENTS            These bits are reserved for future use; mask them out when polling the CSR.</p>	



4.6 Global Status Register

WSMS	OSS	DOS	DSS	QS	PBAS	PBS	PBSS
7	6	5	4	3	2	1	0

<p>GSR.7 = WRITE STATE MACHINE STATUS 1 = Ready 0 = Busy</p> <p>GSR.6 = OPERATION SUSPEND STATUS 1 = Operation Suspended 0 = Operation in Progress/Completed</p> <p>GSR.5 = DEVICE OPERATION STATUS 1 = Operation Unsuccessful 0 = Operation Successful or Currently Running</p> <p>GSR.4 = DEVICE SLEEP STATUS 1 = Device in Sleep 0 = Device Not in Sleep</p> <p>MATRIX <u>5/4</u> 0 0 = Operation Successful or Currently Running 0 1 = Device in Sleep Mode or Pending Sleep 1 0 = Operation Unsuccessful 1 1 = Operation Unsuccessful or Aborted</p> <p>GSR.3 = QUEUE STATUS 1 = Queue Full 0 = Queue Available</p> <p>GSR.2 = PAGE BUFFER AVAILABLE STATUS 1 = One or Two Page Buffers Available 0 = No Page Buffer Available</p> <p>GSR.1 = PAGE BUFFER STATUS 1 = Selected Page Buffer Ready 0 = Selected Page Buffer Busy</p> <p>GSR.0 = PAGE BUFFER SELECT STATUS 1 = Page Buffer 1 Selected 0 = Page Buffer 0 Selected</p>	<p><b>NOTES:</b></p> <p>[1] RY/BY# output or WSMS bit must be checked to determine completion of an operation (block lock, suspend, any RY/BY# reconfiguration, Upload Status Bits, erase or data program) before the appropriate Status bit (OSS or DOS) is checked for success.</p> <p>If operation currently running, then GSR.7 = 0.</p> <p>If device pending sleep, then GSR.7 = 0.</p> <p>Operation aborted: Unsuccessful due to Abort command.</p> <p>The device contains two Page Buffers.</p> <p>Selected Page Buffer is currently busy with WSM operation</p>
---	---

**NOTE:**

- When multiple operations are queued, checking BSR.7 only provides indication of completion for that particular block. GSR.7 provides indication when all queued operations are completed.

### 4.7 Block Status Register

BS	BLS	BOS	BOAS	QS	VPPS	VPPL	R
7	6	5	4	3	2	1	0
<p>BSR.7 = BLOCK STATUS 1 = Ready 0 = Busy</p> <p>BSR.6 = BLOCK LOCK STATUS 1 = Block Unlocked for Program/Erase 0 = Block Locked for Program/Erase</p> <p>BSR.5 = BLOCK OPERATION STATUS 1 = Operation Unsuccessful 0 = Operation Successful or Currently Running</p> <p>BSR.4 = BLOCK OPERATION ABORT STATUS 1 = Operation Aborted 0 = Operation Not Aborted</p> <p>MATRIX <u>5/4</u> 0 0 = Operation Successful or Currently Running 0 1 = Not a Valid Combination 1 0 = Operation Unsuccessful 1 1 = Operation Aborted</p> <p>BSR.3 = QUEUE STATUS 1 = Queue Full 0 = Queue Available</p> <p>BSR.2 = V<sub>PP</sub> STATUS 1 = V<sub>PP</sub> Error Detect, Operation Abort 0 = V<sub>PP</sub> OK</p> <p>BSR.1 = V<sub>PP</sub> LEVEL 1 = V<sub>PP</sub> Detected at 5V ± 10% 0 = V<sub>PP</sub> Detected at 12V ± 5%</p> <p>BSR.0 = RESERVED FOR FUTURE ENHANCEMENTS This bits is reserved for future use; mask it out when polling the BSRs.</p>				<p><b>NOTES:</b> [1] RY/BY# output or BS bit must be checked to determine completion of an operation (block lock, suspend, erase or data program) before the appropriate Status bits (BOS, BLS) is checked for success.</p> <p>The BOAS bit will not be set until BSR.7 = 1.</p> <p>Operation halted via Abort command.</p> <p>BSR.1 is not guaranteed to report accurate feedback between the V<sub>PPH1</sub> and V<sub>PPH2</sub> voltage ranges. Programs and erases with V<sub>PP</sub> between V<sub>PPLK</sub>(max) and V<sub>PPH1</sub>(min), between V<sub>PPH1</sub>(max) and V<sub>PPH2</sub>(min), and above V<sub>PPH2</sub>(max) produce spurious results and should not be attempted. BSR.1 was a RESERVED bit on the 28F016SA.</p>			

**NOTE:**

- When multiple operations are queued, checking BSR.7 only provides indication of completion or that particular block. GSR.7 provides indication when all queued operations are completed.



#### 4.8 Device Configuration Code

R	R	R	R	R	RB2	RB1	RB0
7	6	5	4	3	2	1	0

DCC.2-DCC.0 = RY/BY# CONFIGURATION

(RB2–RB0)

001 = Level Mode (Default)

010 = Pulse-On-Program

011 = Pulse-On-Erase

100 = RY/BY# Disabled

101 = Pulse-On-Program/Erase

**NOTES:**

Undocumented combinations of RB2–RB0 are reserved by Intel Corporation for future implementations and should not be used.

DCC.7–DCC.3 = RESERVED FOR FUTURE ENHANCEMENTS

These bits are reserved for future use; mask them out when reading the Device Configuration Code. Set these bits to “0” when writing the desired RY/BY# configuration to the device.



### 5.0 ELECTRICAL SPECIFICATIONS

#### 5.1 Absolute Maximum Ratings\*

Temperature Under Bias..... 0°C to +80°C  
Storage Temperature.....-65°C to +125°C

NOTICE: This is a production datasheet. The specifications are subject to change without notice. Verify with your local Intel Sales office that you have the latest datasheet before finalizing a design.

*\*WARNING: Stressing the device beyond the "Absolute Maximum Ratings" may cause permanent damage. These are stress ratings only. Operation beyond the "Operating Conditions" is not recommended and extended exposure beyond the "Operating Conditions" may affect device reliability.*

#### V<sub>CC</sub> = 3.3V ± 0.3V Systems

Sym	Parameter	Notes	Min	Max	Units	Test Conditions
T <sub>A</sub>	Operating Temperature, Commercial	1	0	70	°C	Ambient Temperature
V <sub>CC</sub>	V <sub>CC</sub> with Respect to GND	2	-0.2	7.0	V	
V <sub>PP</sub>	V <sub>PP</sub> Supply Voltage with Respect to GND	2,3	-0.2	14.0	V	
V	Voltage on Any Pin (except V <sub>CC</sub> , V <sub>PP</sub> ) with Respect to GND	2,5	-0.5	V <sub>CC</sub> + 0.5	V	
I	Current into Any Non-Supply Pin	5		± 30	mA	
I <sub>OUT</sub>	Output Short Circuit Current	4		100	mA	

#### V<sub>CC</sub> = 5V ± 0.5V, 5V ± 0.25V Systems<sup>(6)</sup>

Sym	Parameter	Notes	Min	Max	Units	Test Conditions
T <sub>A</sub>	Operating Temperature, Commercial	1	0	70	°C	Ambient Temperature
V <sub>CC</sub>	V <sub>CC</sub> with Respect to GND	2	-0.2	7.0	V	
V <sub>PP</sub>	V <sub>PP</sub> Supply Voltage with Respect to GND	2,3	-0.2	14.0	V	
V	Voltage on Any Pin (except V <sub>CC</sub> , V <sub>PP</sub> ) with Respect to GND	2,5	-2.0	7.0	V	
I	Current into Any Non-Supply Pin	5		± 30	mA	
I <sub>OUT</sub>	Output Short Circuit Current	4		100	mA	

**NOTES:**

1. Operating temperature is for commercial product defined by this specification.
2. Minimum DC voltage is -0.5V on input/output pins. During transitions, this level may undershoot to -2.0V for periods <20 ns. Maximum DC voltage on input/output pins is V<sub>CC</sub> + 0.5V which, during transitions, may overshoot to V<sub>CC</sub> + 2.0V for periods <20 ns.
3. Maximum DC voltage on V<sub>PP</sub> may overshoot to +14.0V for periods <20 ns.
4. Output shorted for no more than one second. No more than one output shorted at a time.
5. This specification also applies to pins marked "NC."
6. 5% V<sub>CC</sub> specifications refer to the 28F016SV-065 and 28F016SV-070 in its high speed test configuration.

**SEE NEW DESIGN RECOMMENDATIONS**

## 5.2 Capacitance

For a 3.3V ± 0.3V System:

Sym	Parameter	Notes	Typ	Max	Units	Test Conditions
C <sub>IN</sub>	Capacitance Looking into an Address/Control Pin	1	6	8	pF	T <sub>A</sub> = +25°C, f = 1.0 MHz
C <sub>OUT</sub>	Capacitance Looking into an Output Pin	1	8	12	pF	T <sub>A</sub> = +25°C, f = 1.0 MHz
C <sub>LOAD</sub>	Load Capacitance Driven by Outputs for Timing Specifications	1,2		50	pF	

For 5V ± 0.5V, 5V ± 0.25V System:

Sym	Parameter	Notes	Typ	Max	Units	Test Conditions
C <sub>IN</sub>	Capacitance Looking into an Address/Control Pin	1	6	8	pF	T <sub>A</sub> = +25°C, f = 1.0 MHz
C <sub>OUT</sub>	Capacitance Looking into an Output Pin	1	8	12	pF	T <sub>A</sub> = +25°C, f = 1.0 MHz
C <sub>LOAD</sub>	Load Capacitance Driven by Outputs for Timing Specifications	1,2		100	pF	For V <sub>CC</sub> = 5V ± 0.5V
				30	pF	For V <sub>CC</sub> = 5V ± 0.25V

**NOTE:**

1. Sampled, not 100% tested. Guaranteed by design.
2. To obtain iBIS models for the 28F016SV, please contact your local Intel/Distribution Sales Office.

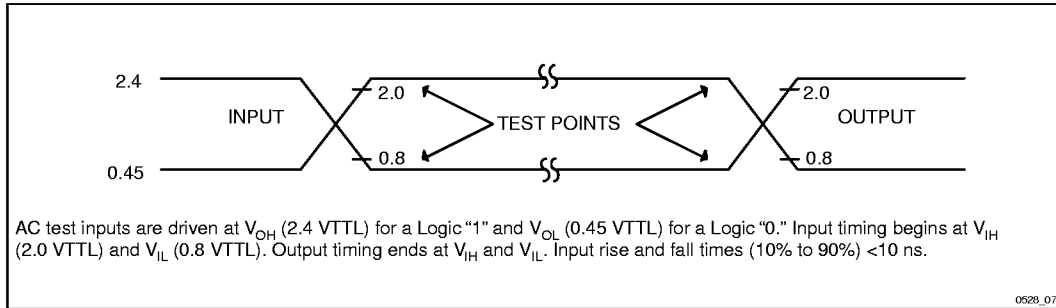

**Figure 7. Transient Input/Output Reference Waveform for  $V_{CC} = 5V \pm 10\%$  (Standard Testing Configuration)<sup>(1)</sup>**

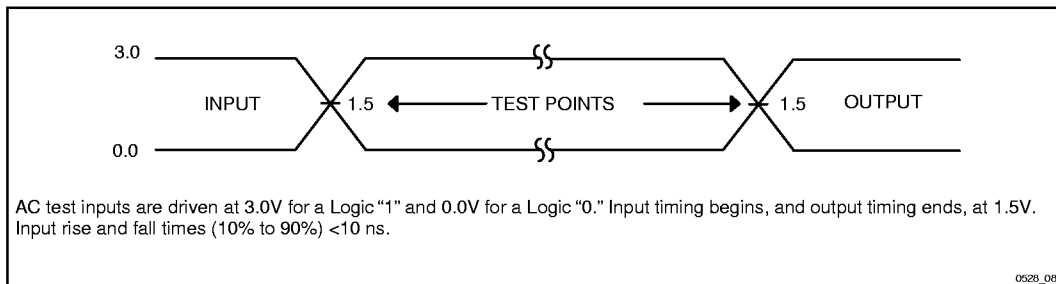

**Figure 8. Transient Input/Output Reference Waveform for  $V_{CC} = 3.3V \pm 0.3V$  and  $V_{CC} = 5V \pm 5\%$  (High Speed Testing Configuration)<sup>(2)</sup>**

**NOTES:**

1. Testing characteristics for 28F016SV-070 (Standard Testing Configuration) and 28F016SV-080.
2. Testing characteristics for 28F016SV-065/28F016SV-075 and 28F016SV-70 (High Speed Testing Configuration)/28F016SV-120.

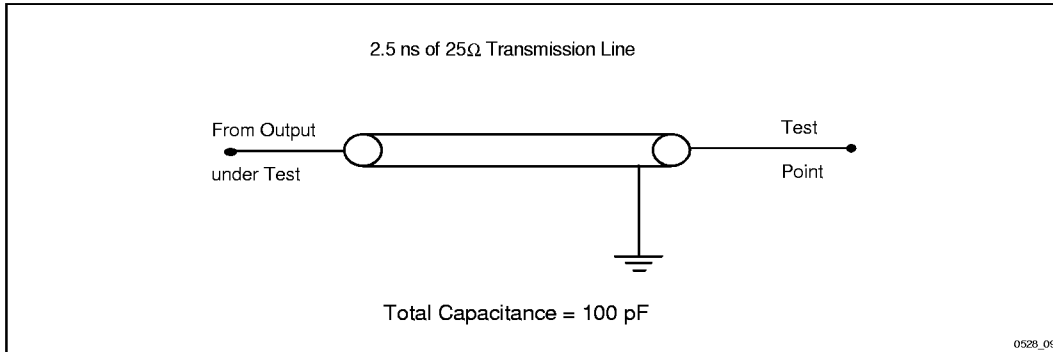

**Figure 9. Transient Equivalent Testing Load Circuit**  
(28F016SV-070/-080 at  $V_{CC} = 5V \pm 10\%$ )

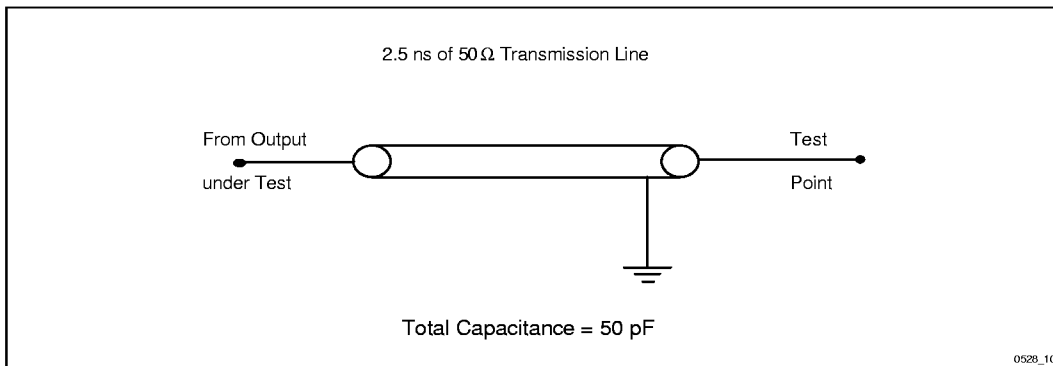

**Figure 10. Transient Equivalent Testing Load Circuit**  
(28F016SV-075/-120 at  $V_{CC} = 3.3V \pm 0.3V$ )

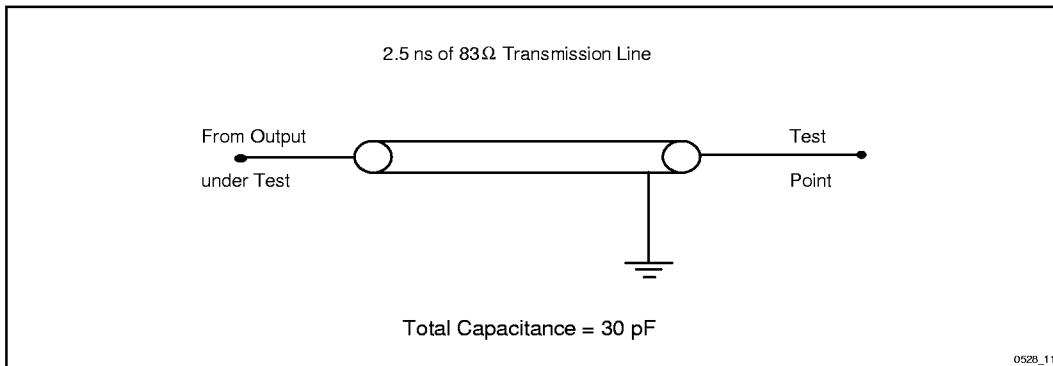

**Figure 11. High Speed Transient Equivalent Testing Load Circuit**  
(28F016SV-065/-070 at  $V_{CC} = 5V \pm 5\%$ )

**5.3 DC Characteristics**
 $V_{CC} = 3.3V \pm 10\%V$ ,  $T_A = 0^\circ C$  to  $+70^\circ C$ ,  $-40^\circ C$  to  $+70^\circ C$ 

3/5# = Pin Set High for 3.3V Operations

Sym	Parameter	Temp	Commercial			Extended			Units	Test Conditions
		Notes	Min	Typ	Max	Min	Typ	Max		
$I_{LI}$	Input Load Current	1			$\pm 1$			$\pm 1$	$\mu A$	$V_{CC} = V_{CC} \text{ Max}$ $V_{IN} = V_{CC} \text{ or GND}$
$I_{LO}$	Output Leakage Current	1			$\pm 10$			$\pm 10$	$\mu A$	$V_{CC} = V_{CC} \text{ Max}$ $V_{OUT} = V_{CC} \text{ or GND}$
$I_{CCS}$	$V_{CC}$ Standby Current	1,5		70	130		70	130	$\mu A$	$V_{CC} = V_{CC} \text{ Max}$ $CE_0\#, CE_1\#, RP\# = V_{CC} \pm 0.2V$ $BYTE\#, WP\#, 3/5\# = V_{CC} \pm 0.2V \text{ or GND} \pm 0.2V$
				1	4		1	4	mA	$V_{CC} = V_{CC} \text{ Max}$ $CE_0\#, CE_1\#, RP\# = V_{IH}$ $BYTE\#, WP\#, 3/5\# = V_{IH} \text{ or } V_{IL}$
$I_{CCD}$	$V_{CC}$ Deep Power-Down Current	1		2	10		5	15	$\mu A$	$RP\# = GND \pm 0.2V$ $BYTE\# = V_{CC} \pm 0.2V \text{ or GND} \pm 0.2V$
$I_{CCR1}$	$V_{CC}$ Read Current	1,4,5		40	50		40	55	mA	$V_{CC} = V_{CC} \text{ Max}$ CMOS: $CE_0\#, CE_1\# = GND \pm 0.2V$ , $BYTE\# = GND \pm 0.2V \text{ or } V_{CC} \pm 0.2V$ , Inputs = $GND \pm 0.2V \text{ or } V_{CC} \pm 0.2V$ TTL: $CE_0\#, CE_1\# = V_{IL}$ , $BYTE\# = V_{IL}$ or $V_{IH}$ . Inputs = $V_{IL} \text{ or } V_{IH}$ $f = 8 \text{ MHz}$ , $I_{OUT} = 0 \text{ mA}$

**SEE NEW DESIGN RECOMMENDATIONS**

### 5.3 DC Characteristics (Continued)

$V_{CC} = 3.3V \pm 10\%V$ ,  $T_A = 0^\circ C$  to  $+70^\circ C$ ,  $-40^\circ C$  to  $+70^\circ C$

3/5# = Pin Set High for 3.3V Operations

Sym	Parameter	Temp	Commercial			Extended			Units	Test Conditions
		Notes	Min	Typ	Max	Min	Typ	Max		
$I_{CCR2}$	$V_{CC}$ Read Current	1,4,5,6		20	30		20	35	mA	$V_{CC} = V_{CC} \text{ Max}$ CMOS: $CE_0\#, CE_1\# = GND \pm 0.2V$ , $BYTE\# = GND \pm 0.2V$ or $V_{CC} \pm 0.2V$ , Inputs = $GND \pm 0.2V$ or $V_{CC} \pm 0.2V$ TTL: $CE_0\#, CE_1\# = V_{IL}$ , $BYTE\# = V_{IL}$ or $V_{IH}$ , Inputs = $V_{IL}$ or $V_{IH}$ $f = 4 \text{ MHz}$ , $I_{OUT} = 0 \text{ mA}$
$I_{CCW}$	$V_{CC}$ Program Current for Word or Byte	1,6		8	12		8	12	mA	$V_{PP} = 12V \pm 5\%$ Program in Progress
				8	17		8	17	mA	$V_{PP} = 5V \pm 10\%$ Program in Progress
$I_{CCE}$	$V_{CC}$ Block Erase Current	1,6		6	12		6	12	mA	$V_{PP} = 12V \pm 5\%$ Block Erase in Progress
				9	17		9	17	mA	$V_{PP} = 5V \pm 10\%$ Block Erase in Progress
$I_{CCES}$	$V_{CC}$ Erase Suspend Current	1,2		1	4		1	4	mA	$CE_0\#, CE_1\# = V_{IH}$ Block Erase Suspended
$I_{PPS}$	$V_{PP}$ Standby/	1		$\pm 1$	$\pm 10$		$\pm 3$	$\pm 10$	$\mu A$	$V_{PP} \leq V_{CC}$
$I_{PPR}$	Read Current			30	200		70	200	$\mu A$	$V_{PP} > V_{CC}$
$I_{PPD}$	$V_{PP}$ Deep Power-Down Current	1		0.2	5		0.2	5	$\mu A$	$RP\# = GND \pm 0.2V$

**5.3 DC Characteristics (Continued)**
 $V_{CC} = 3.3V \pm 10\%V$ ,  $T_A = 0^\circ C$  to  $+70^\circ C$ ,  $-40^\circ C$  to  $+70^\circ C$ 

3/5# = Pin Set High for 3.3V Operations

Sym	Parameter	Temp	Commercial			Extended			Units	Test Conditions
		Notes	Min	Typ	Max	Min	Typ	Max		
I <sub>PPW</sub>	V <sub>PP</sub> Program Current for Word or Byte	1,6		10	15		10	15	mA	V <sub>PP</sub> = 12V ± 5% Program in Progress
				15	25		15	25	mA	V <sub>PP</sub> = 5V ± 10% Program in Progress
I <sub>PPE</sub>	V <sub>PP</sub> Erase Current	1,6		4	10		4	10	mA	V <sub>PP</sub> = 12V ± 5% Block Erase in Progress
				14	20		14	20	mA	V <sub>PP</sub> = 5V ± 10% Block Erase in Progress
I <sub>PPES</sub>	V <sub>PP</sub> Erase Suspend Current	1		30	200		70	200	μA	V <sub>PP</sub> = V <sub>PPH1</sub> or V <sub>PPH2</sub> Block Erase Suspended
V <sub>IL</sub>	Input Low Voltage	6	-0.3		0.8			0.8	V	
V <sub>IH</sub>	Input High Voltage	6	2.0		V <sub>CC</sub> + 0.3			V <sub>CC</sub> + 0.3	V	
V <sub>OL</sub>	Output Low Voltage	6			0.4			0.4	V	V <sub>CC</sub> = V <sub>CC</sub> Min and I <sub>OL</sub> = 4 mA

### 5.3 DC Characteristics (Continued)

$V_{CC} = 3.3V \pm 0.3V$ ,  $T_A = 0^\circ C$  to  $+70^\circ C$ ,  $-40^\circ C$  to  $+85^\circ C$

3/5# = Pin Set High for 3.3V Operations

Sym	Parameter	Temp	Comm/Ext			Units	Test Conditions
		Notes	Min	Typ	Max		
$V_{OH1}$	Output High Voltage	6	2.4			V	$V_{CC} = V_{CC} \text{ Min}$ $I_{OH} = -2.0 \text{ mA}$
$V_{OH2}$		6	0.2			V	$V_{CC} = V_{CC} \text{ Min}$ $I_{OH} = -100 \mu\text{A}$
$V_{PPLK}$	$V_{PP}$ Program/Erase Lock Voltage	3,6	0.0		1.5	V	
$V_{PPH1}$	$V_{PP}$ during Program/Erase Operations	3	4.5	5.0	5.5	V	
$V_{PPH2}$	$V_{PP}$ during Program/Erase Operations	3	11.4	12.0	12.6	V	
$V_{LKO}$	$V_{CC}$ Program/Erase Lock Voltage		2.0			V	

#### NOTES:

- All currents are in RMS unless otherwise noted. Typical values at  $V_{CC} = 3.3V$ ,  $V_{PP} = 12V$  or  $5V$ ,  $T = +25^\circ C$ . These currents are valid for all product versions (package and speeds).
- $I_{CCES}$  is specified with the device de-selected. If the device is read while in erase suspend mode, current draw is the sum of  $I_{CCES}$  and  $I_{CCR}$ .
- Block erases, word/byte programs and lock block operations are inhibited when  $V_{PP} \leq V_{PPLK}$  and not guaranteed in the ranges between  $V_{PPLK}(\text{max})$  and  $V_{PPH1}(\text{min})$ , between  $V_{PPH1}(\text{max})$  and  $V_{PPH2}(\text{min})$  and above  $V_{PPH2}(\text{max})$ .
- Automatic Power Savings (APS) reduces  $I_{CCR}$  to 3.0 mA typical in static operation.
- CMOS Inputs are either  $V_{CC} \pm 0.2V$  or  $GND \pm 0.2V$ . TTL Inputs are either  $V_{IL}$  or  $V_{IH}$ .
- Sampled, but not 100% tested. Guaranteed by design.

**5.4 DC Characteristics**
 $V_{CC} = 5V \pm 0.5V, 5V \pm 0.25V, T_A = 0^\circ C \text{ to } +70^\circ C, -40^\circ C \text{ to } +85^\circ C$ 

3/5# = Pin Set Low for 5V Operations

Sym	Parameter	Temp	Commercial			Extended			Units	Test Conditions
		Notes	Min	Typ	Max	Min	Typ	Max		
$I_{LI}$	Input Load Current	1			$\pm 1$			$\pm 1$	$\mu A$	$V_{CC} = V_{CC} \text{ Max}$ $V_{IN} = V_{CC} \text{ or GND}$
$I_{LO}$	Output Leakage Current	1			$\pm 10$			$\pm 10$	$\mu A$	$V_{CC} = V_{CC} \text{ Max}$ $V_{OUT} = V_{CC} \text{ or GND}$
$I_{CCS}$	$V_{CC}$ Standby Current	1,5		70	130		70	130	$\mu A$	$V_{CC} = V_{CC} \text{ Max}$ $CE_0\#, CE_1\#, RP\# =$ $V_{CC} \pm 0.2V$ BYTE#, WP#, 3/5# $= V_{CC} \pm 0.2V \text{ or}$ $GND \pm 0.2V$
				2	4		2	4	mA	$V_{CC} = V_{CC} \text{ Max},$ $CE_0\#, CE_1\#, RP\# =$ $V_{IH}$ BYTE#, WP#, 3/5# $= V_{IH} \text{ or } V_{IL}$
$I_{CCD}$	$V_{CC}$ Deep Power-Down Current	1		2	10		5	15	$\mu A$	RP# = GND $\pm 0.2V$ BYTE# = $V_{CC} \pm$ $0.2V \text{ or GND} \pm$ $0.2V$
$I_{CCR1}$	$V_{CC}$ Read Current	1,4,5		75	95		75	105	mA	$V_{CC} = V_{CC} \text{ Max}$ CMOS: $CE_0\#, CE_1\#$ $= GND \pm 0.2V,$ BYTE# = GND $\pm$ $0.2V \text{ or } V_{CC} \pm$ $0.2V, \text{ Inputs} =$ GND $\pm 0.2V \text{ or},$ $V_{CC} \pm 0.2V$ TTL: $CE_0\#, CE_1\# =$ $V_{IL}, \text{ BYTE\#} = V_{IL}$ or $V_{IH}, \text{ Inputs} =$ $V_{IL} \text{ or } V_{IH}$ $f = 10 \text{ MHz}, I_{OUT} =$ 0 mA

**SEE NEW DESIGN RECOMMENDATIONS**

### 5.4 DC Characteristics (Continued)

$V_{CC} = 5V \pm 0.5V$ ,  $5V \pm 0.25V$ ,  $T_A = 0^\circ C$  to  $+70^\circ C$ ,  $-40^\circ C$  to  $+85^\circ C$

3/5# = Pin Set Low for 5V Operations

Sym	Parameter	Temp	Commercial			Extended			Units	Test Conditions
		Notes	Min	Typ	Max	Min	Typ	Max		
$I_{CCR2}$	$V_{CC}$ Read Current	1,4,5,6		45	55		45	60	mA	$V_{CC} = V_{CC} \text{ Max}$ CMOS: $CE_{0\#}, CE_{1\#} = GND \pm 0.2V$ , $BYTE\# = GND \pm 0.2V$ or $V_{CC} \pm 0.2V$ , Inputs = $GND \pm 0.2V$ or $V_{CC} \pm 0.2V$ TTL: $CE_{0\#}, CE_{1\#} = V_{IL}$ , $BYTE\# = V_{IL}$ or $V_{IH}$ , Inputs = $V_{IL}$ or $V_{IH}$ $f = 5 \text{ MHz}$ , $I_{OUT} = 0 \text{ mA}$
$I_{CCW}$	$V_{CC}$ Program Current for Word or Byte	1,6		25	35		25	35	mA	$V_{PP} = 12V \pm 5\%$ Program in Progress
				25	40		25	40	mA	$V_{PP} = 5V \pm 10\%$ Program in Progress
$I_{CCE}$	$V_{CC}$ Block Erase Current	1,6		18	25		18	25	mA	$V_{PP} = 12V \pm 5\%$ Block Erase in Progress
				20	30		20	30	mA	$V_{PP} = 5V \pm 10\%$ Block Erase in Progress
$I_{CCES}$	$V_{CC}$ Erase Suspend Current	1,2		2	4		2	4	mA	$CE_{0\#}, CE_{1\#} = V_{IH}$ Block Erase Suspended
$I_{PPS}$	$V_{PP}$ Standby /Read Current	1		$\pm 1$	$\pm 10$		$\pm 3$	$\pm 10$	$\mu A$	$V_{PP} \leq V_{CC}$
$I_{PPR}$	$V_{PP}$ Deep Power-Down Current	1		0.2	5		0.2	5	$\mu A$	$RP\# = GND \pm 0.2V$

**5.4 DC Characteristics (Continued)**
 $V_{CC} = 5V \pm 0.5V, 5V \pm 0.25V, T_A = 0^\circ C \text{ to } +70^\circ C, -40^\circ C \text{ to } +85^\circ C$ 

3/5# = Pin Set Low for 5V Operations

Sym	Parameter	Temp	Commercial			Extended			Units	Test Conditions
		Notes	Min	Typ	Max	Min	Typ	Max		
I <sub>PPW</sub>	V <sub>PP</sub> Program Current for Word or Byte	1,6		7	12		7	12	mA	V <sub>PP</sub> = 12V ± 5% Program in Progress
				17	22		17	22	mA	V <sub>PP</sub> = 5V ± 10% Program in Progress
I <sub>PPE</sub>	V <sub>PP</sub> Block Erase Current	1,6		5	10		5	10	mA	V <sub>PP</sub> = 12V ± 5% Block Erase in Progress
				16	20		16	20	mA	V <sub>PP</sub> = 5V ± 10% Block Erase in Progress
I <sub>PPES</sub>	V <sub>PP</sub> Erase Suspend Current	1		30	200		30	200	μA	V <sub>PP</sub> = V <sub>PPH1</sub> or V <sub>PPH2</sub> Block Erase Suspended
V <sub>IL</sub>	Input Low Voltage	6	-0.5		0.8			0.8	V	
V <sub>IH</sub>	Input High Voltage	6	2.0		V <sub>CC</sub> +0.5			V <sub>CC</sub> +0.5	V	

### 5.4 DC Characteristics (Continued)

$V_{CC} = 5V \pm 0.5V$ ,  $5V \pm 0.25V$ ,  $T_A = 0^\circ C$  to  $+70^\circ C$ ,  $-40^\circ C$  to  $+85^\circ C$

3/5# = Pin Set Low for 5V Operations

Sym	Parameter	Temp	Comm/Extended			Units	Test Conditions
		Notes	Min	Typ	Max		
$V_{OL}$	Output Low Voltage	6			0.45	V	$V_{CC} = V_{CC} \text{ Min}$ $I_{OL} = 5.8 \text{ mA}$
$V_{OH1}$	Output High Voltage	6	0.85 $V_{CC}$			V	$V_{CC} = V_{CC} \text{ Min}$ $I_{OH} = -2.5 \text{ mA}$
$V_{OH2}$		6	$V_{CC} - 0.4$			V	$V_{CC} = V_{CC} \text{ Min}$ $I_{OH} = -100 \mu A$
$V_{PPLK}$	$V_{PP}$ Program/Erase Lock Voltage	3,6	0.0		1.5	V	
$V_{PPH1}$	$V_{PP}$ during Program/Erase Operations		4.5	5.0	5.5	V	
$V_{PPH2}$	$V_{PP}$ during Program/Erase Operations		11.4	12.0	12.6	V	
$V_{LKO}$	$V_{CC}$ Program/Erase Lock Voltage		2.0			V	

#### NOTES:

- All currents are in RMS unless otherwise noted. Typical values at  $V_{CC} = 5V$ ,  $V_{PP} = 12V$  or  $5V$ ,  $T = 25^\circ C$ . These currents are valid for all product versions (package and speeds) and are specified for a CMOS rise/fall time (10% to 90%) of  $<5 \text{ ns}$  and a TTL rise/fall time of  $<10 \text{ ns}$ .
- $I_{CCES}$  is specified with the device de-selected. If the device is read while in erase suspend mode, current draw is the sum of  $I_{CCES}$  and  $I_{CCR}$ .
- Block erases, word/byte programs and lock block operations are inhibited when  $V_{PP} \leq V_{PPLK}$  and not guaranteed in the ranges between  $V_{PPLK}(\text{max})$  and  $V_{PPH1}(\text{min})$ , between  $V_{PPH1}(\text{max})$  and  $V_{PPH2}(\text{min})$  and above  $V_{PPH2}(\text{max})$ .
- Automatic Power Saving (APS) reduces  $I_{CCR}$  to 1 mA typical in Static operation.
- CMOS Inputs are either  $V_{CC} \pm 0.2V$  or  $GND \pm 0.2V$ . TTL Inputs are either  $V_{IL}$  or  $V_{IH}$ .
- Sampled, not 100% tested. Guaranteed by design.

## 5.5 Timing Nomenclature

All 3.3V system timings are measured from where signals cross 1.5V.

For 5V systems use the standard JEDEC cross point definitions (standard testing) or from where signals cross 1.5V (high speed testing).

Each timing parameter consists of 5 characters. Some common examples are defined below:

$t_{CE}$   $t_{ELQV}$  time(t) from CE# (E) going low (L) to the outputs (Q) becoming valid (V)

$t_{OE}$   $t_{GLQV}$  time(t) from OE # (G) going low (L) to the outputs (Q) becoming valid (V)

$t_{ACC}$   $t_{AVQV}$  time(t) from address (A) valid (V) to the outputs (Q) becoming valid (V)

$t_{AS}$   $t_{AVWH}$  time(t) from address (A) valid (V) to WE# (W) going high (H)

$t_{DH}$   $t_{WHDX}$  time(t) from WE# (W) going high (H) to when the data (D) can become undefined (X)

	Pin Characters		Pin States
A	Address Inputs	H	High
D	Data Inputs	L	Low
Q	Data Outputs	V	Valid
E	CE# (Chip Enable)	X	Driven, but Not Necessarily Valid
F	BYTE# (Byte Enable)	Z	High Impedance
G	OE# (Output Enable)		
W	WE# (Write Enable)		
P	RP# (Deep Power-Down Pin)		
R	RY/BY# (Ready Busy)		
V	Any Voltage Level		
Y	3/5# Pin		
5V	V <sub>CC</sub> at 4.5V Minimum		
3V	V <sub>CC</sub> at 3.0V Minimum		

**SEE NEW DESIGN RECOMMENDATIONS**

### 5.6 AC Characteristics—Read Only Operations<sup>(1)</sup>

$V_{CC} = 3.3V \pm 0.3V$ ,  $T_A = 0^\circ C$  to  $+70^\circ C$ ,  $-40^\circ C$  to  $+85^\circ C$

Sym	Parameter	Temp	Commercial		Extended		Commercial		Units
		Speed	-75		-100		-120		
		Notes	Min	Max	Min	Max	Min	Max	
$t_{AVAV}$	Read Cycle Time		75 85 <sup>(10)</sup>		100		120		ns
$t_{AVQV}$	Address to Output Delay			75 85 <sup>(10)</sup>		100		120	ns
$t_{ELQV}$	CE# to Output Delay	2,8		75 85 <sup>(10)</sup>		100		120	ns
$t_{PHQV}$	RP# High to Output Delay			480		620		620	ns
$t_{GLQV}$	OE# to Output Delay	2		40		45		45	ns
$t_{ELQX}$	CE# to Output in Low Z	3,8	0		0		0		ns
$t_{EHQZ}$	CE# to Output in High Z	3,8		30		50		50	ns
$t_{GLQX}$	OE# to Output in Low Z	3	0		0		0		ns
$t_{GHQZ}$	OE# to Output in High Z	3		20		20		20	ns
$t_{OH}$	Output Hold from Address, CE# or OE# Change, Whichever Occurs First	3,8	0		0		0		ns
$t_{FLQV}$ $t_{FHQV}$	BYTE# to Output Delay	3		75 85 <sup>(10)</sup>			100	120	ns
$t_{FLQZ}$	BYTE# Low to Output in High Z	3		30			30	30	ns
$t_{ELFL}$ $t_{ELFH}$	CE# Low to BYTE# High or Low	3,8		5			5	5	ns

#### Extended Status Register Reads

$t_{AVEL}$	Address Setup to CE# Going Low	3,4, 8,9	0		0		0		ns
$t_{AVGL}$	Address Setup to OE# Going Low	3,4,9	0		0		0		ns

**5.6 AC Characteristics—Read Only Operations<sup>(1)</sup>** (Continued)

 $V_{CC} = 5V \pm 0.5V, 5V \pm 0.25V, T_A = 0^\circ C \text{ to } +70^\circ C, -40^\circ C \text{ to } +85^\circ C$ 

Sym	Parameter	Temp	Commercial				Comm/Ext		Units
		Speed	-65		-70		-80		
		V <sub>CC</sub>	5V ± 5%V		5V ± 10%		5V ± 10%		
		Load	30 pF		50 pF		50 pF		
		Notes	Min	Max	Min	Max	Min	Max	
t <sub>AVAV</sub>	Read Cycle Time		65		70		80		ns
t <sub>AVQV</sub>	Address to Output Delay			65		70		80	ns
t <sub>ELQV</sub>	CE# to Output Delay	2,8		65		70		80	ns
t <sub>PHQV</sub>	RP# to Output Delay			400		480 <sup>(6)</sup> 400 <sup>(7)</sup>		480	ns
t <sub>GLQV</sub>	OE# to Output Delay	2		30		30 <sup>(6)</sup> 35 <sup>(7)</sup>		35	ns
t <sub>ELQX</sub>	CE# to Output in Low Z	3,8	0		0		0		ns
t <sub>EHQZ</sub>	CE# to Output in High Z	3,8		25		25		30	ns
t <sub>GLQX</sub>	OE# to Output in Low Z	3	0		0		0		ns
t <sub>GHQZ</sub>	OE# to Output in High Z	3		15		15		20	ns
t <sub>OH</sub>	Output Hold from Address, CE# or OE# Change, Whichever Occurs First	3,8	0		0		0		ns
t <sub>FLQV</sub> t <sub>FHQV</sub>	BYTE# to Output Delay	3		65		70		80	ns
t <sub>FLQZ</sub>	BYTE# Low to Output in High Z	3		25		25		30	ns
t <sub>ELFL</sub> t <sub>ELFH</sub>	CE# Low to BYTE# High or Low	3,8		5		5		5	ns

**Extended Status Register Reads**

t <sub>AVEL</sub>	Address Setup to CE# Going Low	3,4,8,9	0		0		0		ns
t <sub>AVGL</sub>	Address Setup to OE# Going Low	3,4,9	0		0		0		ns

**SEE NEW DESIGN RECOMMENDATIONS**



**NOTES:**

1. See AC Input/Output Reference Waveforms for timing measurements, Figures 7 and 8.
2. OE# may be delayed up to  $t_{ELQV} - t_{GLQV}$  after the falling edge of CE#, without impacting  $t_{ELQV}$ .
3. Sampled, not 100% tested. Guaranteed by design
4. This timing parameter is used to latch the correct BSR data onto the outputs.
5. Device speeds are defined as:
  - 65/70 ns at  $V_{CC} = 5V$  equivalent to
  - 75 ns at  $V_{CC} = 3.3V$
  - 70/80 ns at  $V_{CC} = 5V$  equivalent to
  - 120 ns at  $V_{CC} = 3.3V$
6. See the high speed AC Input/Output Reference Waveforms and AC Testing Load Circuit.
7. See the standard AC Input/Output Reference Waveforms and AC Testing Load Circuit.
8. CE<sub>x</sub># is defined as the latter of CE<sub>0</sub># or CE<sub>1</sub># going low, or the first of CE<sub>0</sub># or CE<sub>1</sub># going high.
9. The address setup requirement for Extended Status Register reads must only be met referenced to the falling edge of the last control signal to become active (CE<sub>0</sub>#, CE<sub>1</sub># or OE#). For example, if CE<sub>0</sub># and CE<sub>1</sub># are activated prior to OE# for an Extended Status Register read, specification  $t_{AVGL}$  must be met. On the other hand, if either CE<sub>0</sub># or CE<sub>1</sub># (or both) are activated after OE#, specification  $t_{AVEL}$  must be referenced.
10. Page Buffer Reads only.

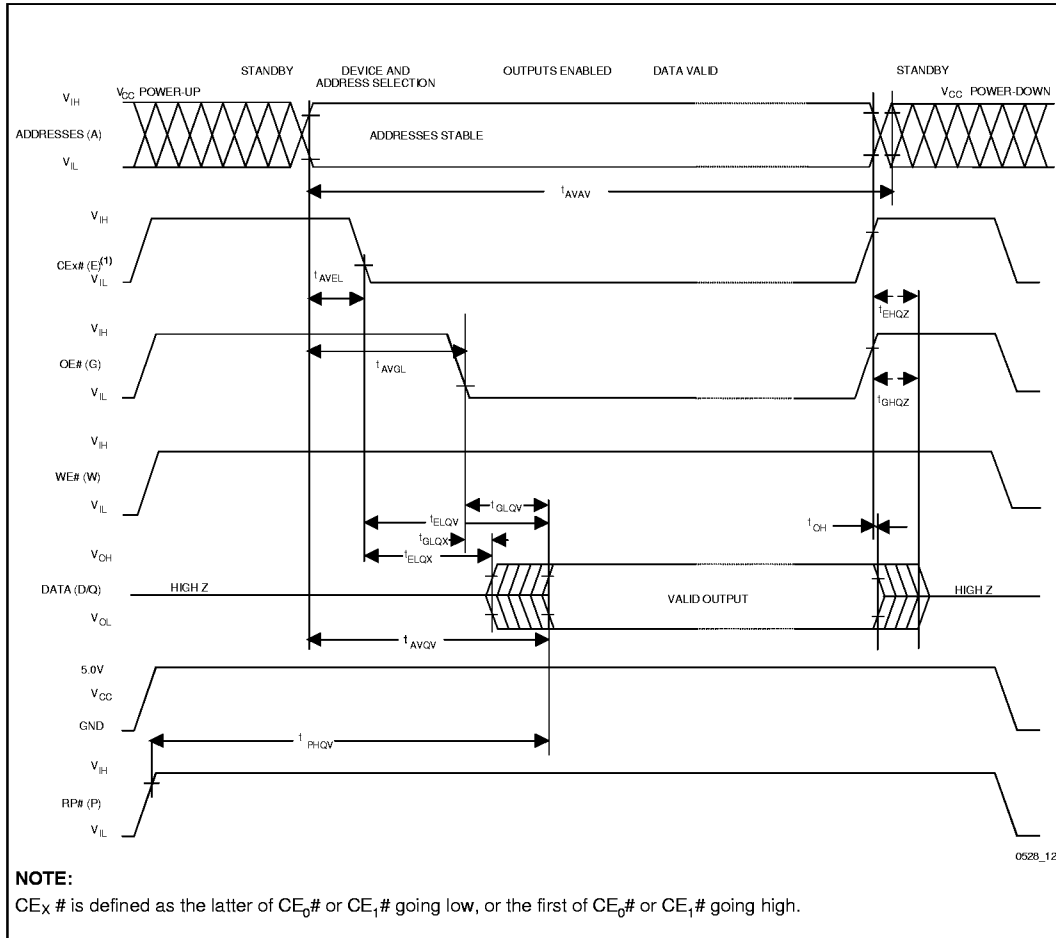

Figure 12. Read Timing Waveforms

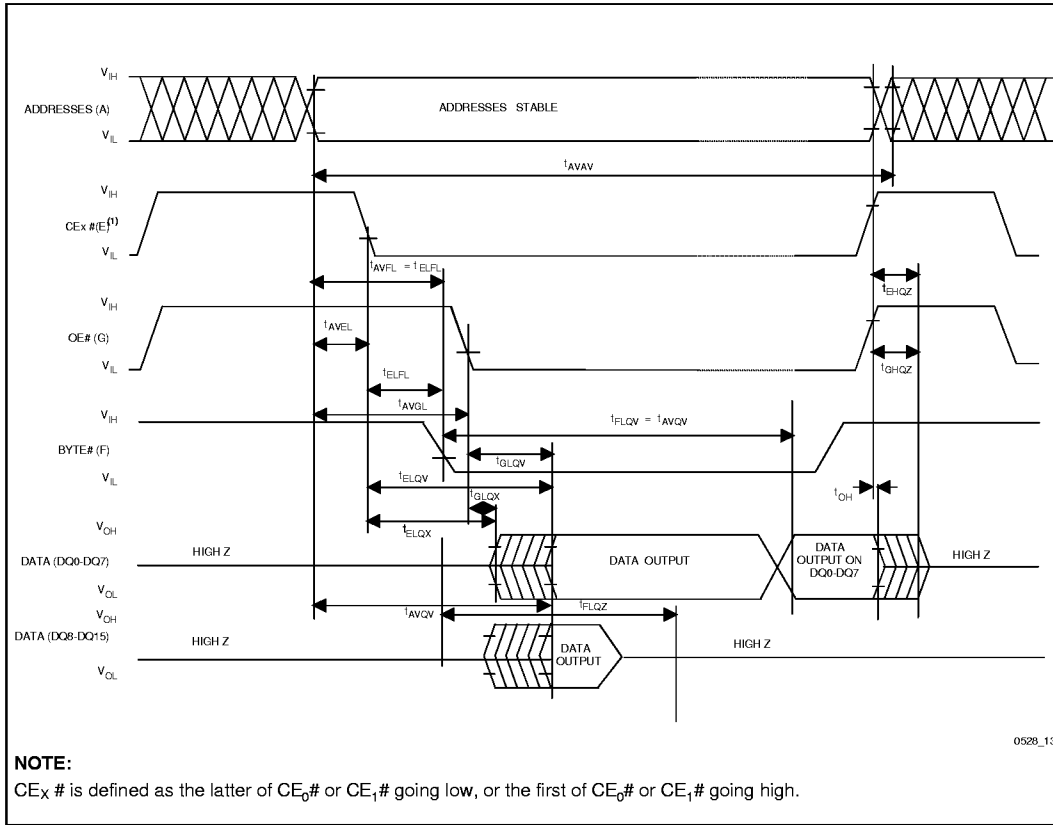

Figure 13. BYTE# Timing Waveforms

### 5.7 Power-Up and Reset Timings

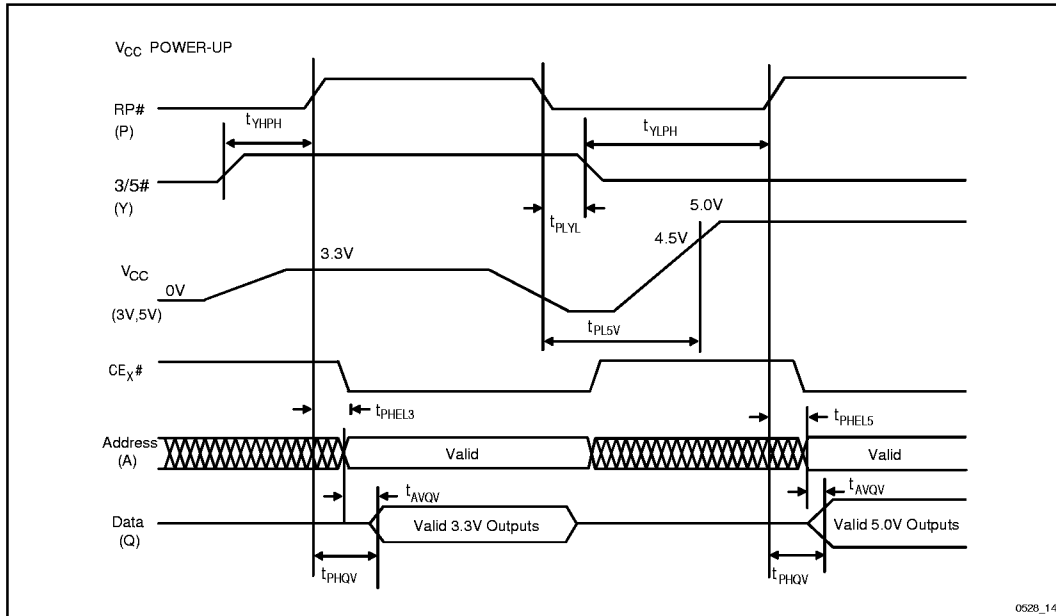

Figure 14. V<sub>CC</sub> Power-Up and RP# Reset Waveforms

Symbol	Parameter	Notes	Min	Max	Unit
t <sub>PLYL</sub> t <sub>PLYH</sub>	RP# Low to 3/5# Low (High)		0		μs
t <sub>YLPH</sub> t <sub>YHPH</sub>	3/5# Low (High) to RP# High	1	2		μs
t <sub>PL5V</sub> t <sub>PL3V</sub>	RP# Low to V <sub>CC</sub> at 4.5V minimum (to V <sub>CC</sub> at 3.0V min or 3.6V max)	2	0		μs
t <sub>PHEL3</sub>	RP# High to CE# Low (3.3V V <sub>CC</sub> )	1	405		ns
t <sub>PHEL5</sub>	RP# High to CE# Low (5V V <sub>CC</sub> )	1	330		ns
t <sub>AVQV</sub>	Address Valid to Data Valid for V <sub>CC</sub> = 5V ± 10%	3		70	ns
t <sub>PHQV</sub>	RP# High to Data Valid for V <sub>CC</sub> = 5V ± 10%	3		400	ns

**NOTES:**

CE<sub>0</sub>#, CE<sub>1</sub># and OE# are switched low after Power-Up.

1. The t<sub>YLPH</sub> and/or t<sub>YHPH</sub> times must be strictly followed to guarantee all other read and program specifications for the 28F016SV.
2. The power supply may start to switch concurrently with RP# going low.
3. The address access time and RP# high to data valid time are shown for 5V V<sub>CC</sub> operation of the 28F016SV-070 (Standard Test Configuration). Refer to the AC Characteristics-Read Only Operations for 3.3V V<sub>CC</sub> and 5V V<sub>CC</sub> (High Speed Test Configuration) values.

**SEE NEW DESIGN RECOMMENDATIONS**

### 5.8 AC Characteristics for WE#—Controlled Command Write Operations<sup>(1)</sup>

$V_{CC} = 3.3V \pm 0.3V$ ,  $T_A = 0^\circ C$  to  $+70^\circ C$ ;  $-40^\circ C$  to  $+85^\circ C$

Sym	Parameter	Temp	Commercial			Extended			Commercial			Unit
		Speed	-75			-100			-120			
		Notes	Min	Typ	Max	Min	Typ	Max	Min	Typ	Max	
$t_{AVAV}$	Write Cycle Time		75			100			120			ns
$t_{VPWH1,2}$	$V_{PP}$ Setup to WE# Going High	3	100			100			100			ns
$t_{PHEL}$	RP# Setup to CE# Going Low	3,7	480			480			480			ns
$t_{ELWL}$	CE# Setup to WE# Going Low	3,7	0 10 <sup>(12)</sup>			10			10			ns
$t_{AVWH}$	Address Setup to WE# Going High	2,6	60			70			75			ns
$t_{DVWH}$	Data Setup to WE# Going High	2,6	60			70			75			ns
$t_{WLWH}$	WE# Pulse Width		60			70			75			ns
$t_{WHDX}$	Data Hold from WE# High	2	5			10			10			ns
$t_{WHAX}$	Address Hold from WE# High	2	5			10			10			ns
$t_{WHEH}$	CE# Hold from WE# High	3,7	5			10			10			ns
$t_{WHWL}$	WE# Pulse Width High		15			30			45			ns
$t_{GHWL}$	Read Recovery before Write	3	0			0			0			ns
$t_{WHRL}$	WE# High to RY/BY# Going Low	3			100			100			100	ns
$t_{RHPL}$	RP# Hold from Valid Status Register (CSR, GSR, BSR) Data and RY/BY# High	3	0			0			0			ns
$t_{PHWL}$	RP# High Recovery to WE# Going Low	3	0.480			1			1			$\mu s$
$t_{WHGL}$	Write Recovery before Read		55			75			95			ns
$t_{QVVL1,2}$	$V_{PP}$ Hold from Valid Status Register (CSR, GSR, BSR) Data and RY/BY# High	3	0			0			0			$\mu s$



5.8 AC Characteristics for WE#—Controlled Command Write Operations(1)  
(Continued)

V<sub>CC</sub> = 3.3V ± 0.3V, T<sub>A</sub> = 0°C to +70°C; -40°C to +85°C

Sym	Parameter	Temp	Commercial			Extended			Commercial			Unit
		Speed	-75			-100			-120			
		Notes	Min	Typ	Max	Min	Typ	Max	Min	Typ	Max	
t <sub>WHQV1</sub>	Duration of Program Operation	3,4,5, 11	5	9	TBD	5	9	TBD	5	9	TBD	μs
t <sub>WHQV2</sub>	Duration of Block Erase Operation	3,4	0.3	0.8	10	0.3	0.8	10	0.3	0.8	10	sec

**SEE NEW DESIGN RECOMMENDATIONS**

### 5.8 AC Characteristics for WE#—Controlled Command Write Operations<sup>(1)</sup>

(Continued)

 $V_{CC} = 5V \pm 0.5V, 5V \pm 0.25V, T_A = 0^\circ C \text{ to } +70^\circ C, -40^\circ C \text{ to } +85^\circ C$ 

Sym	Parameter	Temp	Commercial						Extended			Unit
		Speed	-65			-70			-80			
		V <sub>CC</sub>	5V ± 5%			5V ± 10%			5V ± 10%			
		Load	30 pF			50 pF			50 pF			
		Notes	Min	Typ	Max	Min	Typ	Max	Min	Typ	Max	
t <sub>AVAV</sub>	Write Cycle Time		65			70			80			ns
t <sub>VPWH1</sub> t <sub>VPWH2</sub>	V <sub>PP</sub> Setup to WE# Going High	3	100			100			100			ns
t <sub>PHEL</sub>	RP# Setup to CE# Going Low	3,7	300			480 <sup>(9)</sup> 300 <sup>(10)</sup>			480			ns
t <sub>ELWL</sub>	CE# Setup to WE# Going Low	3,7	0			0			0			ns
t <sub>AVWH</sub>	Address Setup to WE# Going High	2,6	40			50 <sup>(9)</sup> 40 <sup>(10)</sup>			50			ns
t <sub>DVWH</sub>	Data Setup to WE# Going High	2,6	40			50 <sup>(9)</sup> 40 <sup>(10)</sup>			50			ns
t <sub>WLWH</sub>	WE# Pulse Width		40			40 <sup>(9)</sup> 45 <sup>(10)</sup>			50			ns
t <sub>WHDX</sub>	Data Hold from WE# High	2	0			0			0			ns
t <sub>WHAX</sub>	Address Hold from WE# High	2	5			10			10			ns
t <sub>WHEH</sub>	CE# Hold from WE# High	3,7	5			10 <sup>(9)</sup> 5 <sup>(10)</sup>			10			ns
t <sub>WHWL</sub>	WE# Pulse Width High		15			30 <sup>(9)</sup> 15 <sup>(10)</sup>			30			ns
t <sub>GHWL</sub>	Read Recovery before Write	3	0			0			0			ns
t <sub>WHRL</sub>	WE# High to RY/BY# Going Low	3			100			100			100	ns
t <sub>RHPL</sub>	RP# Hold from Valid Status Register (CSR, GSR, BSR) Data and RY/BY# High	3	0			0			0			ns

**5.8 AC Characteristics for WE#—Controlled Command Write Operations<sup>(1)</sup>**

(Continued)

 $V_{CC} = 5V \pm 0.5V, 5V \pm 0.25V, T_A = 0^\circ C \text{ to } +70^\circ C, -40^\circ C \text{ to } +85^\circ C$ 

Sym	Parameter	Temp	Commercial						Extended			Unit
		Speed	-65			-70			-80			
		V <sub>CC</sub>	5V ± 5%			5V ± 10%			5V ± 10%			
		Load	30 pF			50 pF			50 pF			
		Notes	Min	Typ	Max	Min	Typ	Max	Min	Typ	Max	
t <sub>PHWL</sub>	RP# High Recovery to WE# Going Low	3	0.300			1 <sup>(9)</sup> 0.300 <sup>(10)</sup>			1			μs
t <sub>WHGL</sub>	Write Recovery before Read		55			60			65			ns
t <sub>QVVL1</sub> t <sub>QVVL2</sub>	V <sub>PP</sub> Hold from Valid Status Register (CSR, GSR, BSR) Data and RY/BY# High	3	0			0			0			μs
t <sub>WHQV1</sub>	Duration of Program Operation	3,4,5,11	4.5	6	TBD	4.5	6	TBD	4.5	6	TBD	μs
t <sub>WHQV2</sub>	Duration of Block Erase Operation	3,4	0.3	0.6	10	0.3	0.6	10	0.3	0.6	10	sec

**NOTES:**

- Read timings during program and erase are the same as for normal read.
- Refer to command definition tables for valid address and data values.
- Sampled, not 100% tested. Guaranteed by design.
- Program/erase durations are measured to valid Status Register (CSR) Data. V<sub>PP</sub> = 12V ± 0.6V.
- Word/byte program operations are typically performed with 1 Programming Pulse.
- Address and Data are latched on the rising edge of WE# for all command write operations.
- CE<sub>x</sub># is defined as the latter of CE<sub>0</sub># or CE<sub>1</sub># going low, or the first of CE<sub>0</sub># or CE<sub>1</sub># going high.
- Device speeds are defined as:
  - 65/70 ns at V<sub>CC</sub> = 5V equivalent to
  - 75 ns at V<sub>CC</sub> = 3.3V
  - 70/80 ns at V<sub>CC</sub> = 5V equivalent to
  - 120 ns at V<sub>CC</sub> = 3.3V
- See the high speed AC Input/Output Reference Waveforms and AC Testing Load Circuit.
- See the standard AC Input/Output Reference Waveforms and AC Testing Load Circuit.
- The TBD information will be available in a technical paper. Please contact Intel's Application Hotline or your local sales office for more information.
- Page Buffer Programs only.

**SEE NEW DESIGN RECOMMENDATIONS**

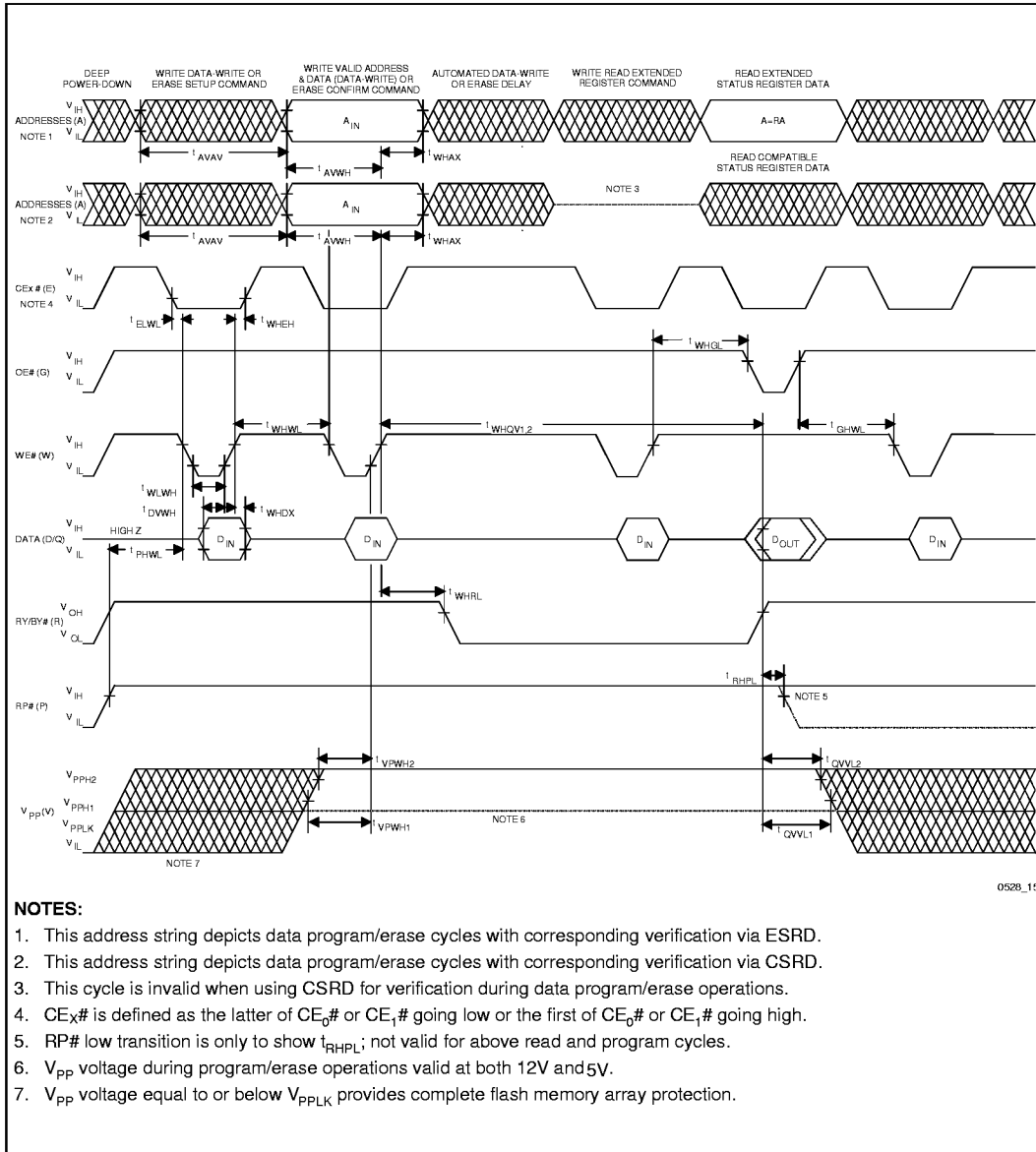

Figure 15. AC Waveforms for Command Write Operations

**5.9 AC Characteristics for CE#—Controlled Command Write Operations<sup>(1)</sup>**
 $V_{CC} = 3.3V \pm 0.3V, T_A = 0^{\circ}C +70^{\circ}C, -40^{\circ}C +85^{\circ}C$ 

Sym	Parameter	Temp	Commercial			Extended			Commercial			Unit
		Speed	-80			-100			-120			
		Notes	Min	Typ	Max	Min	Typ	Max	Min	Typ	Max	
t <sub>AVAV</sub>	Write Cycle Time		80			100			120			ns
t <sub>VPEH</sub> <sup>1,2</sup>	V <sub>PP</sub> Setup to CE# Going High	3,7	100			100			100			ns
t <sub>PHWL</sub>	RP# Setup to WE# Going Low	3	480			480			480			ns
t <sub>WLEL</sub>	WE# Setup to CE# Going Low	3,7	0			0			0			ns
t <sub>AVEH</sub>	Address Setup to CE# Going High	2,6,7	60			70			75			ns
t <sub>DVEH</sub>	Data Setup to CE# Going High	2,6,7	60			70			75			ns
t <sub>LEH</sub>	CE# Pulse Width	7	65			70			75			ns
t <sub>EHDX</sub>	Data Hold from CE# High	2,7	10			10			10			ns
t <sub>EHAX</sub>	Address Hold from CE# High	2,7	10			30			10			ns
t <sub>EHWH</sub>	WE# hold from CE# High	3	5			0			10			ns
t <sub>EHEL</sub>	CE# Pulse Width High	7	15					100	45			ns
t <sub>GHEL</sub>	Read Recovery before Write	3	0			0			0			ns
t <sub>EHRL</sub>	CE# High to RY/BY# Going Low	3,7			100	1					100	ns
t <sub>RHPL</sub>	RP# Hold from Valid Status Register (CSR, GSR, BSR) Data and RY/BY# High	3	0			75			0			ns
t <sub>PHL</sub>	RP# High Recovery to CE# Going Low	3,7	0.480			0			1			μs
t <sub>EHGL</sub>	Write Recovery before Read		55						95			ns

**SEE NEW DESIGN RECOMMENDATIONS**

### 5.9 AC Characteristics for CE#—Controlled Command Write Operations<sup>(1)</sup>

(Continued)

 $V_{CC} = 3.3V \pm 0.3V$ ,  $T_A = 0^\circ C +70^\circ C$ ,  $-40^\circ C +85^\circ C$ 

Sym	Parameter	Temp	Commercial			Extended			Commercial			Unit
		Speed	-80			-100			-120			
		Notes	Min	Typ	Max	Min	Typ	Max	Min	Typ	Max	
$t_{QVVL1,2}$	$V_{PP}$ Hold from Valid Status Register (CSR, GSR, BSR) Data and RY/BY# High	3	0						0			$\mu s$
$t_{EHQV1}$	Duration of Program Operation	3,4,5,11	5	9	TBD	5	9	TBD	5	9	TBD	$\mu s$
$t_{EHQV2}$	Duration of Block Erase Operation	3,4	0.3	0.8	10	0.3	0.8	10	0.3	0.8	10	sec

**5.9 AC Characteristics for CE#—Controlled Command Write Operations(1)**

(Continued)

 $V_{CC} = 5V \pm 0.5V, 5V \pm 0.25V, T_A = 0^\circ \text{ to } +70^\circ\text{C}, -40^\circ\text{C to } +85^\circ\text{C}$ 

Sym	Parameter	Temp	Commercial						Extended			Unit
		Speed	-65			-70			-80			
		VCC	5V ± 5%			5V ± 10%			5V ± 10%			
		Load	30 pF			50 pF			50 pF			
		Notes	Min	Typ	Max	Min	Typ	Max	Min	Typ	Max	
t <sub>AVAV</sub>	Write Cycle Time		65			70			80			ns
t <sub>VPEH1,2</sub>	V <sub>PP</sub> Setup to CE# Going High	3,7	100			100			100			ns
t <sub>PHWL</sub>	RP# Setup to WE# Going Low	3	300			480 <sup>(9)</sup> 300 <sup>(10)</sup>			480			ns
t <sub>WLEL</sub>	WE# Setup to CE# Going Low	3,7	0			0			0			ns
t <sub>AVEH</sub>	Address Setup to CE# Going High	2,6,7	40			50 <sup>(9)</sup> 45 <sup>(10)</sup>			50			ns
t <sub>DVEH</sub>	Data Setup to CE# Going High	2,6,7	40			50 <sup>(9)</sup> 45 <sup>(10)</sup>			50			ns
t <sub>ELEH</sub>	CE# Pulse Width	7	45			45 <sup>(9)</sup> 50 <sup>(10)</sup>			50			ns
t <sub>EHDx</sub>	Data Hold from CE# High	2,7	0			0			0			ns
t <sub>EHAX</sub>	Address Hold from CE# High	2,7	10			10			10			ns
t <sub>EHWH</sub>	WE# Hold from CE# High	3,7	5			10 <sup>(9)</sup> 5 <sup>(10)</sup>			10			ns
t <sub>EHEL</sub>	CE# Pulse Width High	7	15			30 <sup>(9)</sup> 15 <sup>(10)</sup>			30			ns
t <sub>GHEL</sub>	Read Recovery before Write	3	0			0			0			ns
t <sub>EHRL</sub>	CE# High to RY/BY# Going Low	3,7			100			100			100	ns
t <sub>RHPL</sub>	RP# Hold from Valid Status Register (CSR, GSR, BSR) Data and RY/BY# High	3	0			0			0			ns

**SEE NEW DESIGN RECOMMENDATIONS**

### 5.9 AC Characteristics for CE#—Controlled Command Write Operations<sup>(1)</sup>

(Continued)

 $V_{CC} = 5V \pm 0.5V, 5V \pm 0.25V, T_A = 0^\circ \text{ to } +70^\circ\text{C}, -40^\circ\text{C to } +85^\circ\text{C}$ 

Sym	Parameter	Temp	Commercial						Extended			Unit
		Speed	-65			-70			-80			
		V <sub>CC</sub>	5V ± 5%			5V ± 10%			5V ± 10%			
		Load	30 pF			50 pF			50 pF			
		Notes	Min	Typ	Max	Min	Typ	Max	Min	Typ	Max	
t <sub>PHL</sub>	RP# High Recovery to CE# Going Low	3,7	0.300			1 <sup>(9)</sup> 0.300 <sup>(10)</sup>			1			μs
t <sub>EHGL</sub>	Write Recovery before Read		55			60			65			ns
t <sub>QVVL</sub> <sup>1,2</sup>	V <sub>PP</sub> Hold from Valid Status Register (CSR, GSR, BSR) Data at RY/BY# High	3	0			0			0			μs
t <sub>EHQV</sub> <sup>1</sup>	Duration of Program Operation	3,4,5,11	4.5	6	TBD	4.5	6	TBD	4.5	6	TBD	μs
t <sub>EHQV</sub> <sup>2</sup>	Duration of Block Erase Operation	3,4	0.3	0.6	10	0.3	0.6	10	0.3	0.6	10	sec

**NOTES:**

- Read timings during program and erase are the same as for normal read.
- Refer to command definition tables for valid address and data values.
- Sampled, not 100% tested. Guaranteed by design.
- Program/erase durations are measured to valid Status Data. V<sub>PP</sub> = 12V ± 0.6V.
- Word/byte program operations are typically performed with 1 Programming Pulse.
- Address and Data are latched on the rising edge of CE# for all command write operations.
- CE<sub>x</sub># is defined as the latter of CE<sub>0</sub># or CE<sub>1</sub># going low, or the first of CE<sub>0</sub># or CE<sub>1</sub># going high.
- Device speeds are defined as:
  - 65/70 ns at V<sub>CC</sub> = 5V equivalent to
  - 75 ns at V<sub>CC</sub> = 3.3V
  - 70/80 ns at V<sub>CC</sub> = 5V equivalent to
  - 120 ns at V<sub>CC</sub> = 3.3V
- See the high speed AC Input/Output Reference Waveforms and AC Testing Load Circuit.
- See the standard AC Input/Output Reference Waveforms and AC Testing Load Circuit.
- The TBD information will be available in a technical paper. Please contact Intel's Application Hotline or your local sales office for more information.

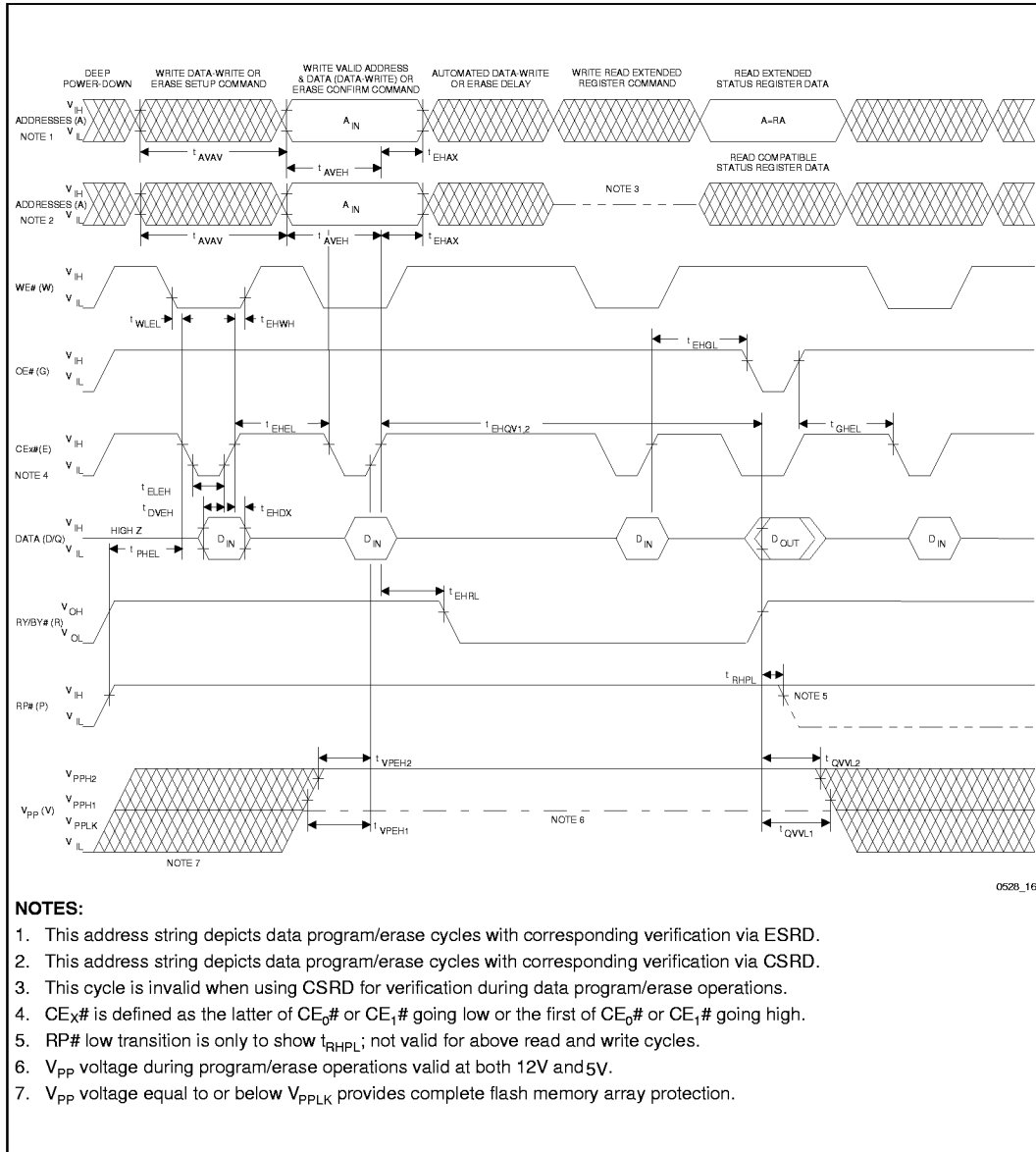

Figure 16. Alternate AC Waveforms for Command Write Operations

### 5.10 AC Characteristics for WE#—Controlled Page Buffer Write Operations<sup>(1)</sup>

$V_{CC} = 3.3V \pm 0.3V$ ,  $T_A = 0^\circ C$  to  $+70^\circ C$ ,  $-40^\circ C$  to  $+85^\circ C$

Sym	Parameter	Temp	Commercial/Extended			Unit
		Speed	-75, -100, -120			
		Notes	Min	Typ	Max	
$t_{AVWL}$	Address Setup to WE# Going Low	2	0			ns

$V_{CC} = 5V \pm 0.5V$ ,  $5V \pm 0.25V$ ,  $T_A = 0^\circ C$  to  $+70^\circ C$ ,  $-40^\circ C$  to  $+85^\circ C$

Sym	Parameter	Temp	Commercial			Comm/Ext			Unit			
		Speed	-65			-70				-80		
		$V_{CC}$	$5V \pm 5\%$			$5V \pm 10\%$				$5V \pm 10\%$		
		Load	30 pF			50 pF				50 pF		
		Notes	Min	Typ	Max	Min	Typ	Max		Min	Typ	Max
$t_{AVWL}$	Address Setup to WE# Going Low	2	0			0			0			ns

#### NOTES:

- All other specifications for WE#—Controlled Write Operations can be found in section 5.8.
- Address must be valid during the entire WE# low pulse.
- Device speeds are defined as:
  - 65/70 ns at  $V_{CC} = 5V$  equivalent to
  - 75 ns at  $V_{CC} = 3.3V$
  - 70/80 ns at  $V_{CC} = 5V$  equivalent to
  - 120 ns at  $V_{CC} = 3.3V$
- See the high speed AC Input/Output Reference Waveforms and AC Testing Load Circuit.
- See the standard AC Input/Output Reference Waveforms and AC Testing Load Circuit.

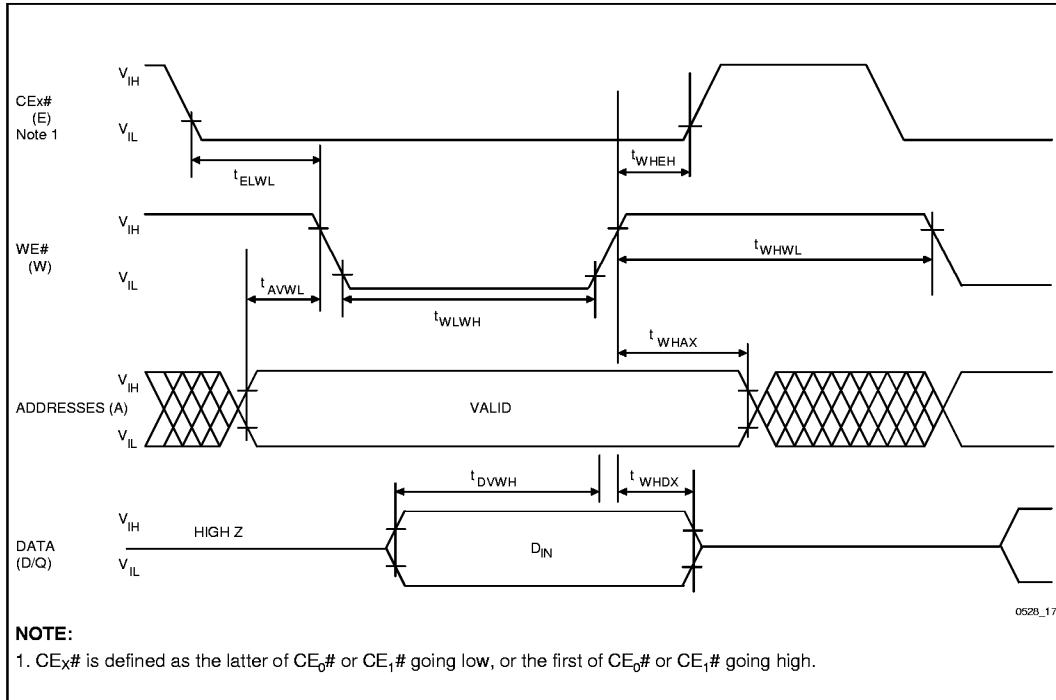

**Figure 17. WE#—Controlled Page Buffer Write Timing Waveforms (Loading Data to the Page Buffer)**

### 5.11 AC Characteristics for CE#—Controlled Page Buffer Write Operations<sup>(1)</sup>

$V_{CC} = 3.3V \pm 0.3V$ ,  $T_A = 0^\circ C$  to  $+70^\circ C$ ,  $-40^\circ C$  to  $+85^\circ C$

Sym	Parameter	Temp	Commercial/Extended			Unit
		Speed	-75, -100, -120			
		Notes	Min	Typ	Max	
$t_{A\text{VEL}}$	Address Setup to CE# Going Low	2,3	0			ns

$V_{CC} = 5V \pm 0.5V$ ,  $5V \pm 0.25V$ ,  $T_A = 0^\circ C$  to  $+70^\circ C$ ,  $-40^\circ C$  to  $+85^\circ C$

Sym	Parameter	Temp	Commercial			Comm/Ext			Unit			
		Speed	-65			-70				-80		
		$V_{CC}$	$5V \pm 5\%$			$5V \pm 10\%$				$5V \pm 10\%$		
		Load	30 pF			50 pF				50 pF		
		Notes	Min	Typ	Max	Min	Typ	Max		Min	Typ	Max
$t_{A\text{VEL}}$	Address Setup to CE# Going Low	2,3	0			0			0			ns

#### NOTES:

- All other specifications for CE#—Controlled Write Operations can be found in Section 5.9.
- Address must be valid during the entire WE# low pulse.
- CE<sub>x</sub># is defined as the latter of CE<sub>0</sub># or CE<sub>1</sub># going low, or the first of CE<sub>0</sub># or CE<sub>1</sub># going high.
- Device speeds are defined as:
  - 65/70 ns at  $V_{CC} = 5V$  equivalent to
  - 75 ns at  $V_{CC} = 3.3V$
  - 70/80 ns at  $V_{CC} = 5V$  equivalent to
  - 120 ns at  $V_{CC} = 3.3V$
- See the high speed AC Input/Output Reference Waveforms and AC Testing Load Circuit.
- See the standard AC Input/Output Reference Waveforms and AC Testing Load Circuit.

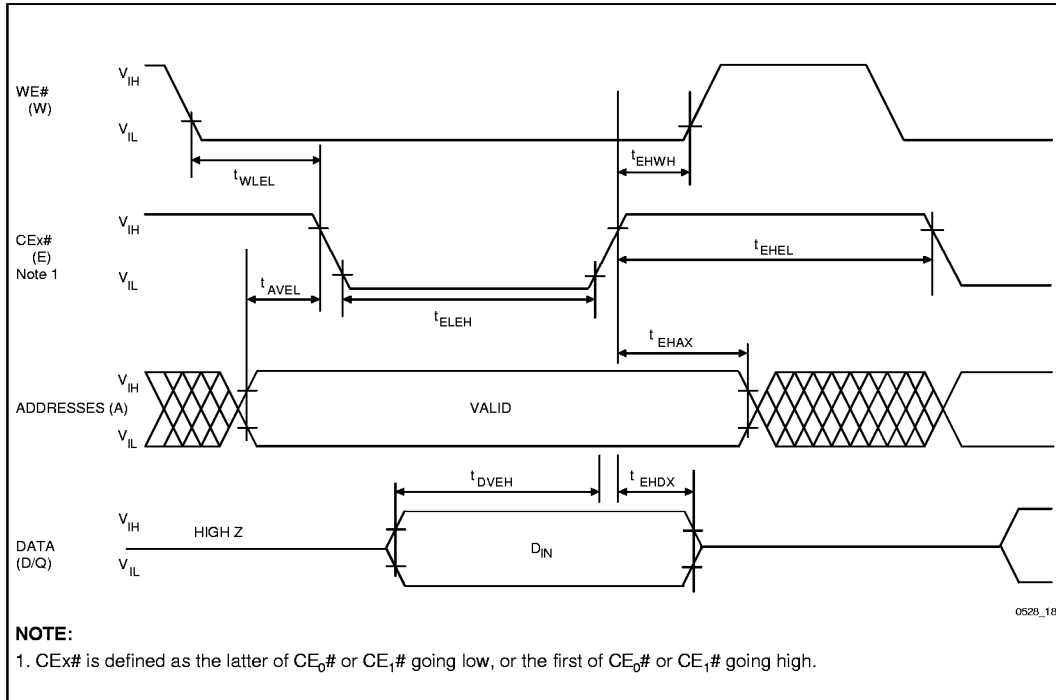

**Figure 18. CE#—Controlled Page Buffer Write Timing Waveforms (Loading Data to the Page Buffer)**

### 5.12 Erase and Word/Byte Program Performance<sup>(3,5)</sup>

$V_{CC} = 3.3V \pm 0.3V$ ,  $V_{PP} = 5V \pm 0.5V$ ,  $T_A = 0^\circ C$  to  $+70^\circ C$

Symbol	Parameter	Notes	Min	Typ <sup>(1)</sup>	Max	Units	Test Conditions
	Page Buffer Byte Write Time	2,6,7	TBD	8.0	TBD	$\mu s$	
	Page Buffer Word Write Time	2,6,7	TBD	16.0	TBD	$\mu s$	
$t_{WHRH1A}$	Byte Program Time	2,7	TBD	29.0	TBD	$\mu s$	
$t_{WHRH1B}$	Word Program Time	2,7	TBD	35.0	TBD	$\mu s$	
$t_{WHRH2}$	Block Program Time	2,7	TBD	1.9	TBD	sec	Byte Prog. Mode
$t_{WHRH3}$	Block Program Time	2,7	TBD	1.2	TBD	sec	Word Prog. Mode
	Block Erase Time	2,7	TBD	1.4	TBD	sec	
	Full Chip Erase Time	2,7	TBD	44.8	TBD	sec	
	Erase Suspend Latency Time to Read	4	1.0	12	75	$\mu s$	
	Auto Erase Suspend Latency Time to Program		4.0	15	80	$\mu s$	

$V_{CC} = 3.3V \pm 0.3V$ ,  $V_{PP} = 12V \pm 0.6V$ ,  $T_A = 0^\circ C$  to  $+70^\circ C$

Symbol	Parameter	Notes	Min	Typ <sup>(1)</sup>	Max	Units	Test Conditions
	Page Buffer Byte Write Time	2,6,7	TBD	2.2	TBD	$\mu s$	
	Page Buffer Word Write Time	2,6,7	TBD	4.4	TBD	$\mu s$	
$t_{WHRH1}$	Word/Byte Program Time	2,7	5	9	TBD	$\mu s$	
$t_{WHRH2}$	Block Program Time	2,7	TBD	0.6	2.1	sec	Byte Prog. Mode
$t_{WHRH3}$	Block Program Time	2,7	TBD	0.3	1.0	sec	Word Prog. Mode
	Block Erase Time	2	0.3	0.8	10	sec	
	Full Chip Erase Time	2,7	TBD	25.6	TBD	sec	
	Erase Suspend Latency Time to Read	4	1.0	9	55	$\mu s$	
	Auto Erase Suspend Latency Time to Program		4.0	12	60	$\mu s$	

**5.12 Erase and Word/Byte Program Performance<sup>(3,5)</sup> (Continued)**
 $V_{CC} = 5V \pm 0.5V, 5V \pm 0.25V, V_{PP} = 5V \pm 0.5V, T_A = 0^\circ C \text{ to } +70^\circ C$ 

Symbol	Parameter	Notes	Min	Typ <sup>(1)</sup>	Max	Units	Test Conditions
	Page Buffer Byte Write Time	2,6,7	TBD	8.0	TBD	μs	
	Page Buffer Word Write Time	2,6,7	TBD	16.0	TBD	μs	
t <sub>WHRH1A</sub>	Byte Program Time	2,7	TBD	20	TBD	μs	
t <sub>WHRH1B</sub>	Word Program Time	2,7	TBD	25	TBD	μs	
t <sub>WHRH2</sub>	Block Program Time	2,7	TBD	1.4	TBD	sec	Byte Prog. Mode
t <sub>WHRH3</sub>	Block Program Time	2,7	TBD	0.85	TBD	sec	Word Prog. Mode
	Block Erase Time	2,7	TBD	1.0	TBD	sec	
	Full Chip Erase Time	2,7	TBD	32.0	TBD	sec	
	Erase Suspend Latency Time to Read	4	1.0	9	55	μs	
	Auto Erase Suspend Latency Time to Program		3.0	12	60	μs	

 $V_{CC} = 5V \pm 0.5V, 5V \pm 0.25V, V_{PP} = 12V \pm 0.6V, T_A = 0^\circ C \text{ to } +70^\circ C$ 

Symbol	Parameter	Notes	Min	Typ <sup>(1)</sup>	Max	Units	Test Conditions
	Page Buffer Byte Write Time	2,6,7	TBD	2.1	TBD	μs	
	Page Buffer Word Write Time	2,6,7	TBD	4.1	TBD	μs	
t <sub>WHRH1</sub>	Word/Byte Program Time	2,7	4.5	6	TBD	μs	
t <sub>WHRH2</sub>	Block Program Time	2,7	TBD	0.4	2.1	sec	Byte Prog. Mode
t <sub>WHRH3</sub>	Block Program Time	2,7	TBD	0.2	1.0	sec	Word Prog. Mode
	Block Erase Time	2	0.3	0.6	10	sec	
	Full Chip Erase Time	2,7	TBD	19.2	TBD	sec	
	Erase Suspend Latency Time to Read	4	1.0	7	40	μs	
	Auto Erase Suspend Latency Time to Program		3.0	10	45	μs	

**NOTES:**

- +25°C, and nominal voltages.
- Excludes system-level overhead.
- These performance numbers are valid for all speed versions.
- Specification applies to interrupt latency for single block erase. Suspend latency for erase all unlocked blocks operation extends the maximum latency time to 270 μs.
- Sampled, but not 100% tested. Guaranteed by design.
- Assumes using the full Page Buffer to Program to Flash (256 bytes or 128 words).
- The TBD information will be available in a technical paper. Please contact Intel's Application Hotline or your local sales office for more information.

**SEE NEW DESIGN RECOMMENDATIONS**

6.0 MECHANICAL SPECIFICATIONS

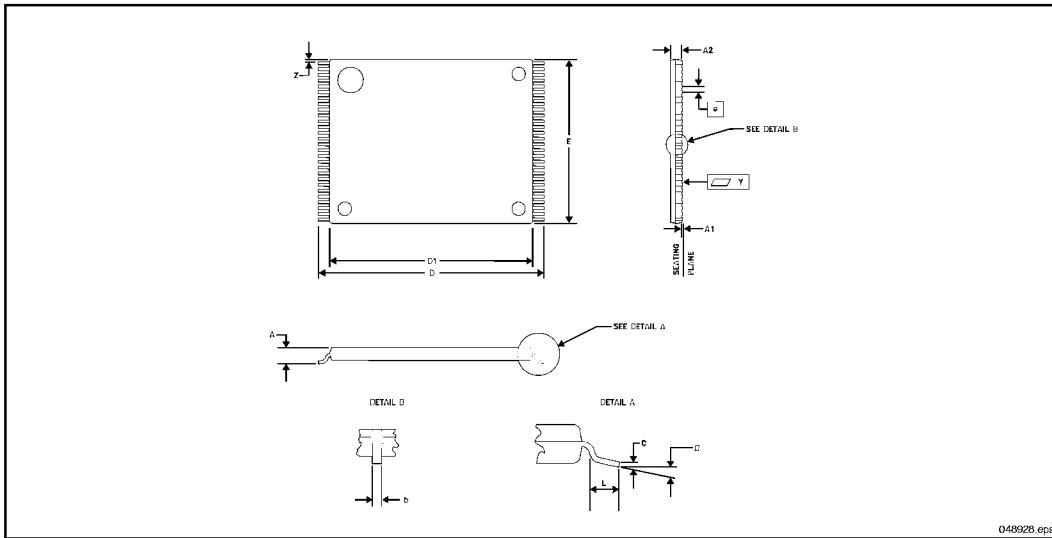

Figure 19. Mechanical Specifications of the 28F016SV 56-Lead TSOP Type I Package

Family: Thin Small Out-Line Package				
Symbol	Millimeters			Notes
	Minimum	Nominal	Maximum	
A			1.20	
A1	0.050			
A2	0.965	0.995	1.025	
b	0.100	0.150	0.200	
c	0.115	0.125	0.135	
D1	18.20	18.40	18.60	
E	13.80	14.00	14.20	
e		0.50		
D	19.80	20.00	20.20	
L	0.500	0.600	0.700	
N		56		
∅	0°	3°	5°	
Y			0.100	
Z	0.150	0.250	0.350	

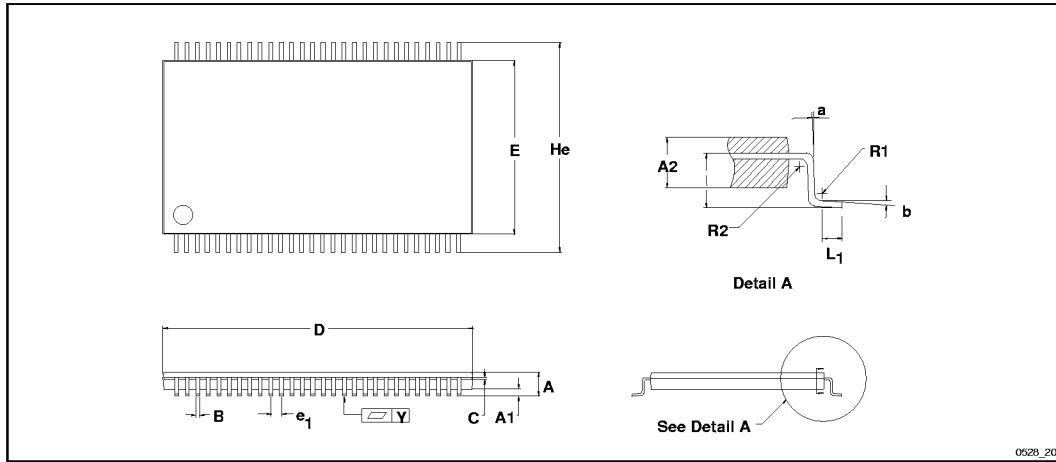

Figure 20. Mechanical Specifications of the 28F016SV 56-Lead SSOP Type I Package

Family: Shrink Small Out-Line Package				
Symbol	Millimeters			Notes
	Minimum	Nominal	Maximum	
A		1.80	1.90	
A1	0.47	0.52	0.57	
A2	1.18	1.28	1.38	
B	0.25	0.30	0.40	
C	0.13	0.15	0.20	
D	23.40	23.70	24.00	
E	13.10	13.30	13.50	
e <sub>1</sub>		0.80		
He	15.70	16.00	16.30	
N		56		
L <sub>1</sub>	0.45	0.50	0.55	
Y			0.10	
a	2°	3°	4°	
b	3°	4°	5°	
R1	0.15	0.20	0.25	
R2	0.15	0.20	0.25	

**SEE NEW DESIGN RECOMMENDATIONS**



7.0 DEVICE NOMENCLATURE AND ORDERING INFORMATION

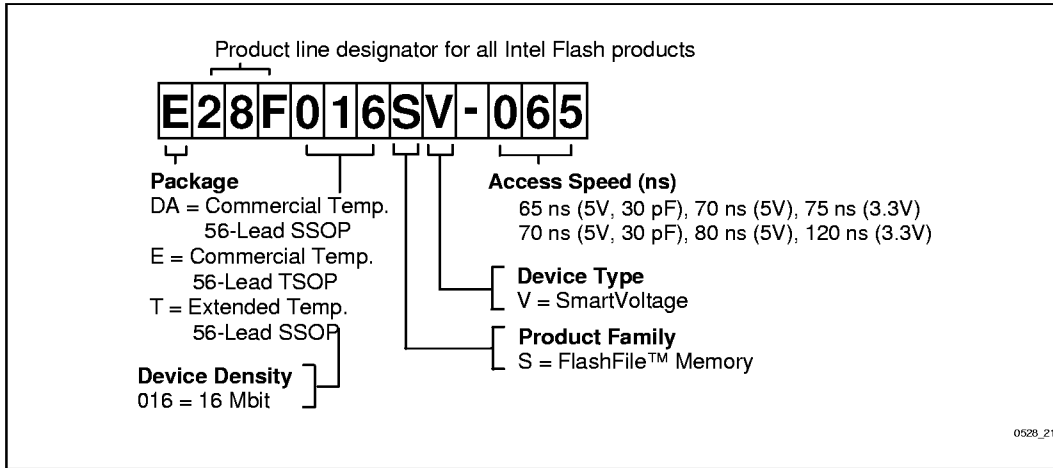

Option	Order Code	Valid Combinations		
		V <sub>CC</sub> = 3.3V ± 0.3V, 50 pF load, 1.5V I/O Levels <sup>(1)</sup>	V <sub>CC</sub> = 5V ± 10%, 100 pF load TTL I/O Levels <sup>(1)</sup>	V <sub>CC</sub> = 5V ± 5%, 30 pF load 1.5V I/O Levels <sup>(1)</sup>
1	E28F016SV 070	E28F016SV-120	E28F016SV-080	E28F016SV-070
2	E28F016SV 065	E28F016SV-075	E28F016SV-070	E28F016SV-065
3	DA28F016SV 070	DA28F016SV-120	DA28F016SV-080	DA28F016SV-070
4	DA28F016SV 065	DA28F016SV-075	DA28F016SV-070	DA28F016SV-065
5	DT28F016SV 080	DT28F016SV-100	DT28F016SV-080	DT28F016SV-080

**NOTE:**

- See Section 5.2 for Transient Input/Output Reference Waveforms and Testing Load Circuits.



### 8.0 ADDITIONAL INFORMATION

Order Number	Document/Tool
297372	16-Mbit Flash Product Family User's Manual
290608	Word-Wide FlashFile™ Memory Family 28F160S3, 28F320S3 datasheet
290609	Word-Wide FlashFile™ Memory Family 28F160S5, 28F320S5 datasheet
290598	Byte-Wide Smart 3 FlashFile™ Memory Family datasheet
290597	Byte-Wide Smart 5 FlashFile™ Memory Family datasheet
290429	28F008SA Datasheet
292126	AP-377 16-Mbit Flash Product Family Software Drivers, 28F016SA/28F016SV/28F016XS/28F016XD
292144	AP-393 28F016SV Compatibility with 28F016SA
292159	AP-607 Multi-Site Layout Planning with Intel's FlashFile™ Components, Including ROM Capability
292163	AP-610 Flash Memory In-System Code and Data Update Techniques
292165	AB-62 Compiled Code Optimizations for Flash Memories
297554	28F016SV Specification Update
297508	FLASHBuilder Utility
Contact Intel/Distribution Sales Office	Flash Cycling Utility
Contact Intel/Distribution Sales Office	28F016SV iBIS Model
Contact Intel/Distribution Sales Office	28F016SV VHDL
Contact Intel/Distribution Sales Office	28F016SV Timing Designer Library Files
Contact Intel/Distribution Sales Office	28F016SV Orcad and ViewLogic Schematic Symbols

**NOTES:**

1. Please call the Intel Literature Center at (800) 548-4725 to request Intel documentation. International customers should contact their local Intel or distribution sales office.
2. Visit Intel's World Wide Web home page at <http://www.Intel.com> for technical documentation and tools.

**SEE NEW DESIGN RECOMMENDATIONS**