



AAT4651 5V/3V PC Card Power Switch

SmartSwitch™

General Description

The AAT4651 SmartSwitch™ is a single channel PC Card (PCMCIA) power switch. It is used to select between two different voltage inputs, each between 2.7V and 5.5V. An internal switch powers the circuitry from whichever input voltage is higher. The device's output, V_{CC} , is slew rate controlled and current limited, in compliance with PC Card specifications. The current limit response time to a short circuit is typically 1 μ s. The internal P-Channel MOSFET switches are configured to break before make, that is, both switches cannot be closed at the same time. Controlled by a 2 bit parallel interface, the three states for V_{CC} are V_{CC5} , V_{CC3} , or Ground. When in the ground state, V_{CC} is pulled to ground by an 200 Ω resistor. An open drain FAULT output is asserted during over-current conditions. During power up slewing, FAULT also signals that V_{CC} is out of tolerance. An internal over temperature sensor forces V_{CC} to a high impedance state when an over-temperature condition exists. Quiescent current is typically a low 15 μ A, as long as I_{CC} is less than approximately 500mA. Above this load current, the quiescent current increases to 200 μ A.

The AAT4651 is available in 8-pin SOP and TSSOP packages specified over -40 to 85°C.

Features

- 2.7V to 5.5V Input voltage range
- 80m Ω (5V) typical $R_{DS(ON)}$
- Low quiescent current 15 μ A (typ)
- Reverse-blocking switches
- Short-circuit protection
- Over-temperature protection
- FAULT flag output
- Temp range -40 to 85°C
- 8 pin SOP or TSSOP package

Applications

- Notebook Computer
- PDA, Subnotebook
- Power Supply Multiplexer Circuit

Typical Application

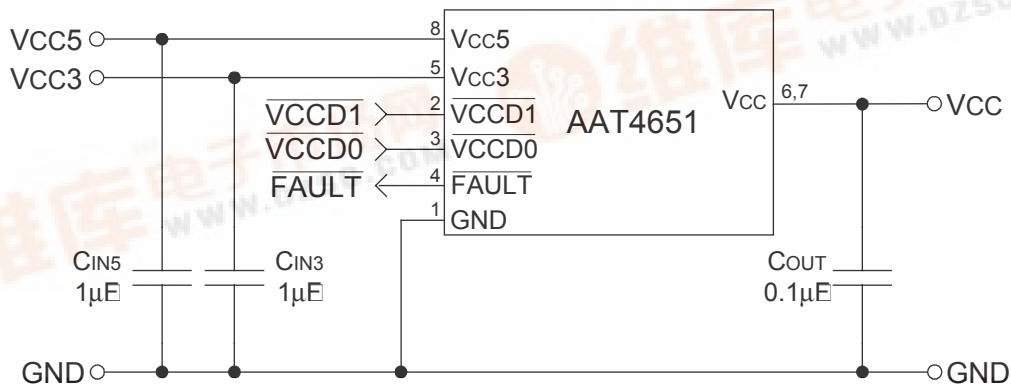

Pin Descriptions

| Pin # | Symbol | Function |
|-------|---------------------------|--|
| 1 | GND | Ground connection |
| 2 | $\overline{\text{VCCD1}}$ | Control input (see Control Logic Table below) |
| 3 | $\overline{\text{VCCD0}}$ | Control input (see Control Logic Table below) |
| 4 | $\overline{\text{FAULT}}$ | Open drain output signals over-current condition |
| 5 | V_{CC3} | 3V supply |
| 6 | V_{CC} | Output (see Control Logic Table below) |
| 7 | V_{CC} | Output (see Control Logic Table below) |
| 8 | V_{CC5} | 5V supply |

Pin Configuration

SO-8 / TSSOP-8
(Top View)

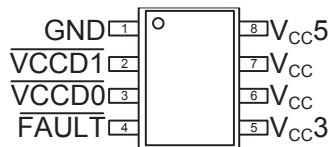

Control Logic Table

| $\overline{\text{VCCD1}}$ | $\overline{\text{VCCD0}}$ | Function | Result |
|---------------------------|---------------------------|----------|------------------------------------|
| 0 | 0 | OFF | 80 Ω V_{CC} to GND |
| 0 | 1 | 3.3V | $V_{\text{CC}}=V_{\text{CC3}}$ |
| 1 | 0 | 5V | $V_{\text{CC}}=V_{\text{CC5}}$ |
| 1 | 1 | OFF | 80 Ω V_{CC} to GND |

Absolute Maximum Ratings ($T_A=25^\circ\text{C}$ unless otherwise noted)

| Symbol | Description | Value | Units |
|--------------------|--------------------------------------|-----------------|------------------|
| V_{CC3}, V_{CC5} | IN to GND | -0.3 to 6 | V |
| V_{CC} | OUT to GND | -0.3 to 6 | V |
| I_{MAX} | Maximum Continuous Switch Current | Current Limited | A |
| T_J | Operating Junction Temperature Range | -40 to 150 | $^\circ\text{C}$ |
| V_{ESD} | ESD Rating ¹ — HBM | 4000 | V |

Note: Stresses above those listed in Absolute Maximum Ratings may cause permanent damage to the device. Functional operation at conditions other than the operating conditions specified is not implied. Only one Absolute Maximum rating should be applied at any one time.

Note 1: Human body model is a 100pF capacitor discharged through a 1.5k Ω resistor into each pin.

Thermal Characteristics

| Symbol | Description | Value | Units |
|---------------|---|-------|---------------------------|
| Θ_{JA} | Thermal Resistance (SOP-8) ² | 120 | $^\circ\text{C}/\text{W}$ |
| Θ_{JA} | Thermal Resistance (TSSOP-8) ² | 150 | $^\circ\text{C}/\text{W}$ |
| P_D | Power Dissipation (SOP-8) ² | 1.0 | W |
| P_D | Power Dissipation (TSSOP-8) ² | 833 | mW |

Note 2: Mounted on an FR4 board.

Electrical Characteristics ($V_{CC5} = 5.0\text{V}$, $V_{CC3} = 3.3\text{V}$, $T_A = -40$ to 85°C unless otherwise noted. Typical values are at $T_A=25^\circ\text{C}$; **bold** values designate full temperature range)

| Symbol | Description | Conditions | Min | Typ | Max | Units |
|---|-------------------------------|--|------------|------|-------------|-----------------------|
| V_{CC} Output | | | | | | |
| I_{CCSC} | Short Circuit Current Limit | $V_{CC}=V_{CCIN} -0.5\text{V}$, ON mode V_{CC3} or V_{CC5} selected, $T_A=25^\circ\text{C}$ | 1.0 | | 2.5 | A |
| $R_{DS(ON)}$ | On-Resistance | $V_{CC}=3.0\text{V}$, $T_A=25^\circ\text{C}$ | | 85 | 110 | m Ω |
| | | $V_{CC}=5.0\text{V}$, $T_A=25^\circ\text{C}$ | | 80 | 100 | m Ω |
| R_{CLAMP} | Clamp Resistance | $V_{CC} = \text{clamped to GND}$, $I_{CCOUT} = 10\text{mA}$ sinking | | 80 | 200 | Ω |
| T_{crds} | Switch Resistance Tempco | | | 2800 | | ppm/ $^\circ\text{C}$ |
| V_{CC} Switching Time (Refer to Figure 1) | | | | | | |
| t1 | Output Turn-On Delay Time | $V_{CC}=0\text{V}$ to 10% of 3.3V, $R_{OUT}=10\Omega$ | | 500 | 2000 | μs |
| t2 | Output Turn-On Delay Time | $V_{CC}=0\text{V}$ to 10% of 5.0V, $R_{OUT}=10\Omega$ | | 500 | 1500 | μs |
| t3 | Output Rise Time | $V_{CC}=10\%$ to 90% of 3.3V, $R_{LOAD}=10\Omega$ | 300 | 1000 | 3000 | μs |
| t4 | Output Rise Time | $V_{CC}=10\%$ to 90% of 5.0V, $R_{LOAD}=10\Omega$ | 300 | 1000 | 3000 | μs |
| t5 | Output Turn-Off Delay Time | $V_{CC}=3.3$ to 90% of 3.3V, $R_{LOAD}=10\Omega$ | | | 400 | μs |
| t6 | Output Turn-Off Delay Time | $V_{CC}=5.0$ to 90% of 5.0V, $R_{LOAD}=10\Omega$ | | | 400 | μs |
| t7 | Output Fall Time to OFF State | $V_{CC}=90\%$ to 10% of 3.3V, $R_{LOAD}=10\Omega$ | | | 200 | μs |
| t8 | Output Fall Time to OFF State | $V_{CC}=90\%$ to 10% of 5.0V, $R_{LOAD}=10\Omega$ | | | 200 | μs |

| Symbol | Description | Conditions | Min | Typ | Max | Units |
|--|--|--|------------|------|------------|-------|
| Power Supply | | | | | | |
| V _{CC3} | V _{CC3} Operation Voltage | | 2.7 | | 5.5 | V |
| V _{CC5} | V _{CC5} Operation Voltage | | 2.7 | | 5.5 | V |
| I _{CC3} | V _{CC3} Supply Current | V _{CC} =5V or OFF, V _{CC3} <V _{CC5} , I _{CC} Out=0 | | | 1 | μA |
| | | V _{CC} =3.3v, V _{CC3} <V _{CC5} , I _{CC} Out=0 | | 5 | 20 | μA |
| I _{CC5} | V _{CC5} Supply Current | V _{CC} =Off, V _{CC5} >V _{CC3} , I _{CC} Out=0 | | | 1 | μA |
| | | V _{CC} =3.3v, V _{CC5} >V _{CC3} , I _{CC} Out=0 | | 10 | 40 | μA |
| | | V _{CC} =5v, V _{CC5} >V _{CC3} , I _{CC} Out=0 | | 15 | 40 | μA |
| Parallel Interface | | | | | | |
| V _{CCD} LOW | V _{CCD} Input Low Voltage | V _{CC3} or V _{CC5} =3.0 to 5.5V ³ | | | 0.8 | V |
| V _{CCD} HI | V _{CCD} Input High Voltage | V _{CC3} or V _{CC5} =2.7 to 3.6V | 2.0 | | | V |
| | | V _{CC3} or V _{CC5} =4.5 to 5.5V | 2.4 | | | V |
| I _{SINK} $\overline{V_{CCD}}$ | V _{CCD} Input leakage | V _{CTL} = 5.5V | | 0.01 | 1 | μA |
| V _{FAULTLOW} | \overline{FAULT} Logic Output Low Voltage | I _{SINK} =1mA | | | 0.4 | V |
| I _{SINK} \overline{FAULT} | \overline{FAULT} Logic Output High Leakage Current | V _{FAULT} = 5.5V | | 0.05 | 1 | μA |
| Other | | | | | | |
| OTMP | Over Temperature Shutdown | | | 125 | | degC |

Note 3: For $\overline{V_{CCD}}$ outside this range consult Typical $\overline{V_{CCD}}$ Threshold curve.

Timing Diagram

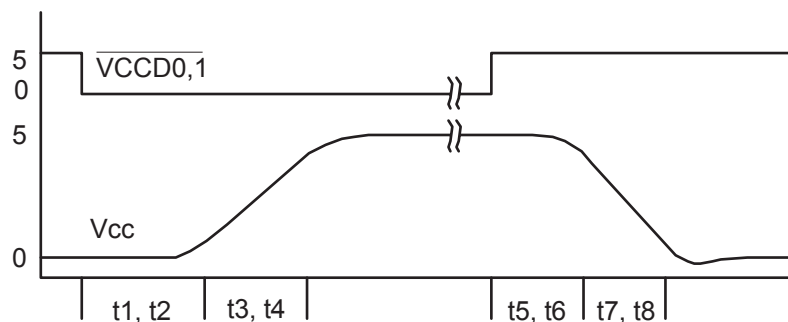

Figure 1: V_{CC} Switching Time Diagram

Refer to V_{CC} Switching Time specifications under the Electrical Characteristics section for definitions of t1 to t8.

Typical Characteristics

(Unless otherwise noted, $T_A = 25^\circ\text{C}$)

Quiescent Current vs. Temperature
(I_{CC5})

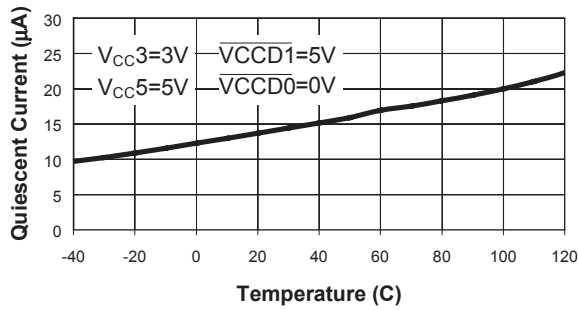

Current Limit $V_{CC}=V_{CC3}$

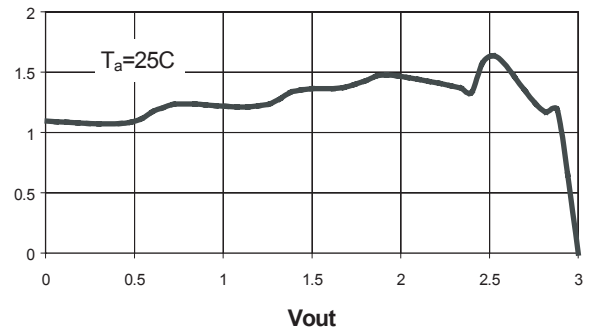

Current Limit $V_{CC}=V_{CC5}$

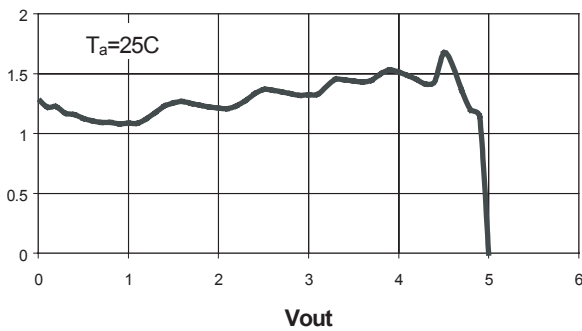

Off-Switch Current vs. Temperature (I_{CC3})

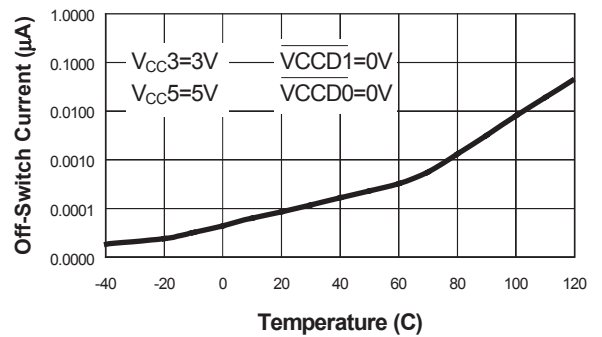

Off-Switch Current vs. Temperature I_{CC5}

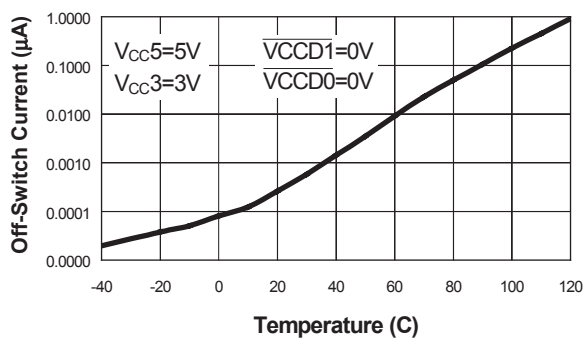

Rdson vs. Temperature

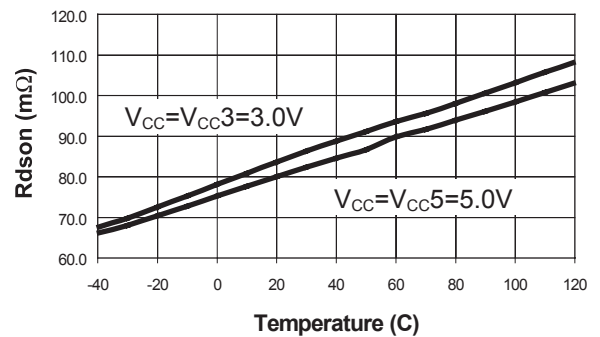

(Unless otherwise noted, $T_A = 25^\circ\text{C}$)

**Turn-ON/OFF Response with 10Ω,
1μF load ($\overline{\text{VCCD1}} = 0\text{V}$)**

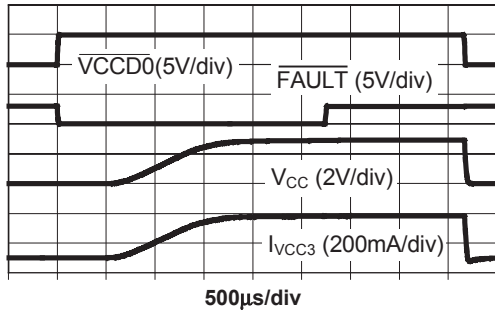

**Turn-ON/OFF Response with 15Ω,
1μF load ($\overline{\text{VCCD0}} = 0\text{V}$)**

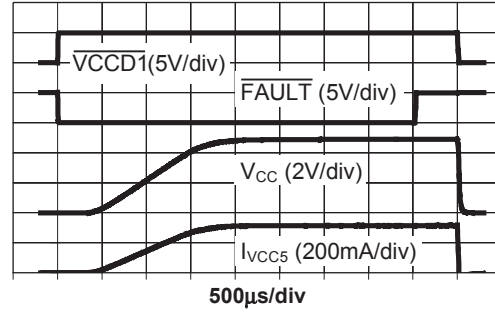

**Thermal Shutdown Response
($\overline{\text{VCCD0}} = 0\text{V}$)**

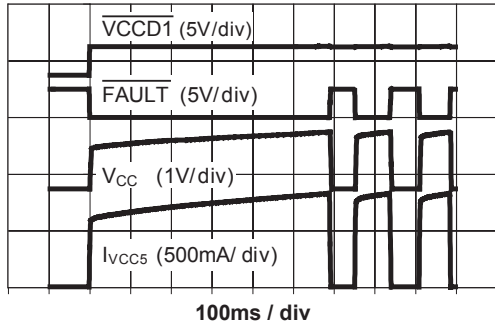

Short Circuit Through 0.3 Ohm

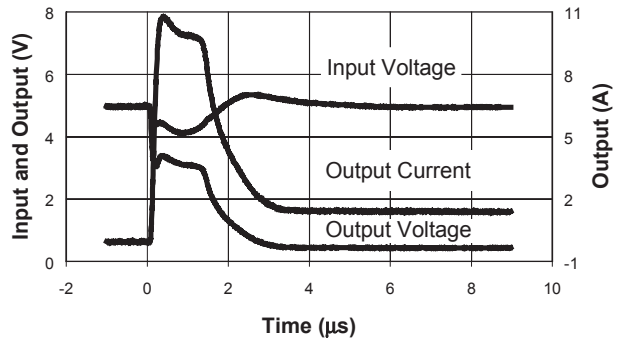

Short Circuit Through 0.6 Ohm

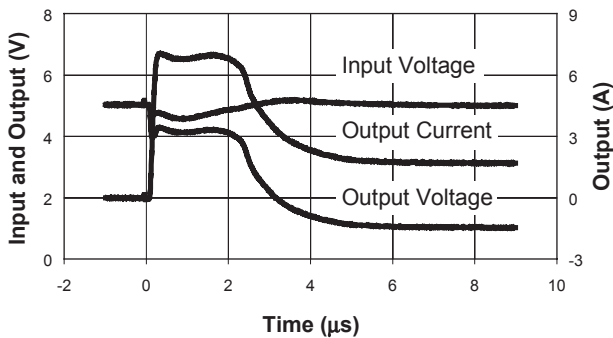

$\overline{\text{VCCD}}$ Threshold vs. V_{CC}

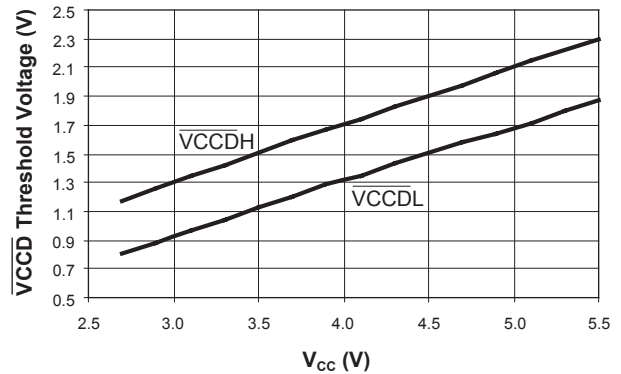

Functional Block Diagram

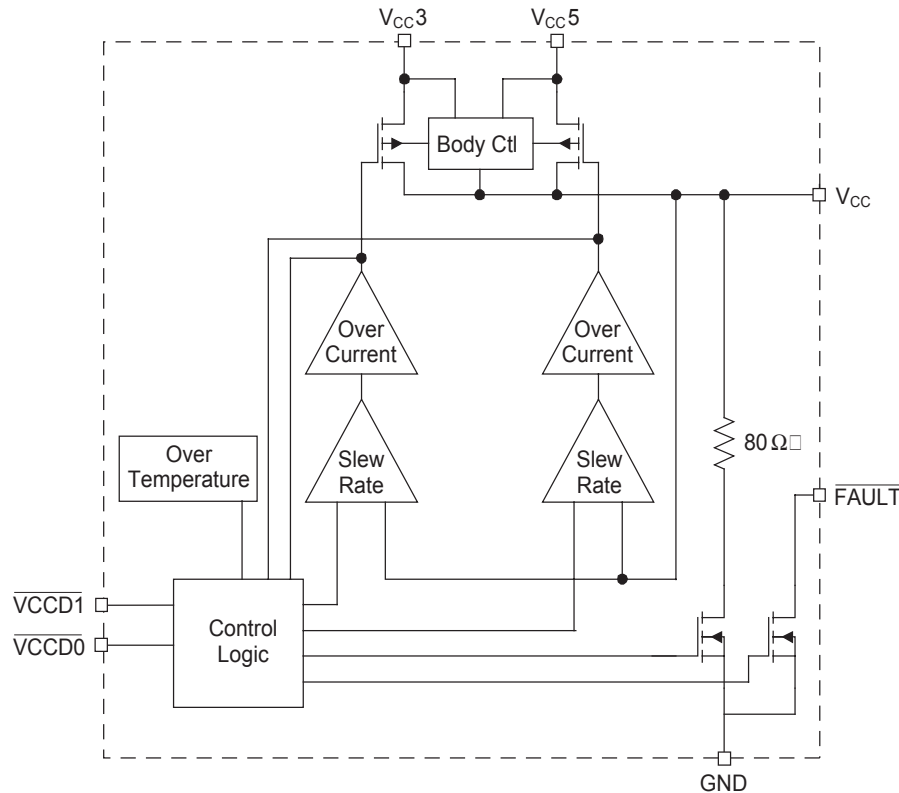

Functional Description

The AAT4651 is a single channel power switch that can be used in any application where dual power supply multiplexing is required. Typical applications for this include PC card applications not requiring a 12 volt power supply, or applications where power is switched, for example, between 5 volts for operation and 3.3 volts for standby mode. The AAT4651 operates with input voltages ranging from 2.7 to 5.5 volts in any combination and automatically powers its internal circuitry off of whichever input voltage is higher. Two identical low R_{DS} P-channel MOSFETS serve as the power multiplexing circuit with a common drain as the V_{CC} output and independent sources as the two V_{CC3} and V_{CC5} inputs. A two bit parallel interface determines the state of the multiplexer: $V_{CC}=V_{CC3}$, $V_{CC}=V_{CC5}$, or V_{CC} with resistive pull down to ground. When the state is set to either of the two inputs, the multiplexing circuit will slowly

slew the V_{CC} output to the new voltage level which protects the upstream power supply from sudden load transients. When the resistive pull down is chosen for V_{CC} , the V_{CC} output is quickly discharged by the resistive pull down. The AAT4651 always serves as an electronic fuse by limiting the load current if it exceeds the current limit threshold. During power up into a short, the current will gradually increase until the current limit is reached. During a sudden short circuit on the output, the current limit will respond in 1 μ s to isolate and protect the upstream power supply from the load short circuit. In most applications, because the response time is so fast, a short circuit to V_{CC} will not affect the upstream supply, so system functionality will not be affected. In the case of an over current condition, an open drain $\overline{\text{FAULT}}$ flag output will signal the event. The $\overline{\text{FAULT}}$ output is also active during output voltage slew, and becomes inactive once the output is within regulation.

Applications Information

Input Capacitor

Typically a 1 μ F or larger capacitor is recommended for C_{IN} . A C_{IN} capacitor is not required for basic operation, however, it is useful in preventing load transients from affecting up stream circuits. C_{IN} should be located as close to the device V_{IN} pin as practically possible. Ceramic, tantalum or aluminum electrolytic capacitors may be selected for C_{IN} . There is no specific capacitor ESR requirement for C_{IN} . However, for higher current operation, ceramic capacitors are recommended for C_{IN} due to their inherent capability over tantalum capacitors to withstand input current surges from low impedance sources such as batteries in portable devices.

Output Capacitor

A 0.1 μ F or greater capacitor is generally required between V_{CC} and GND. Likewise, with the output capacitor, there is no specific capacitor ESR requirement. If desired, C_{OUT} may be increased to accommodate any load transient condition.

Parallel Interface / Break Before Make

A two bit parallel interface determines the state of the V_{CC} output. The logic levels are compatible with CMOS or TTL logic. A logic low value must be less than 0.8 volts, and a logic high value must be greater than 2.4 volts. In cases where the interface pins rapidly change state directly from 3v to 5v (or vice versa), internal break before make circuitry prevents any back flow of current from one input power supply to the other. In addition, the body connections of the internal P-channel MOSFET switches are always set to the highest potential of V_{CC3} , V_{CC5} , or V_{CC} , which prevents any body diode conduction, power supply backflow, or possible device damage.

FAULT Output

The FAULT output is pulled to ground by an open drain N-channel MOSFET during an over current or output slew condition. It should be pulled up to the reference power supply of the controller IC via a nominal 100K Ω resistor.

Voltage Regulation

The PC Card Specification calls for a regulated 5 volt supply tolerance of +/-5%. Of this, a typical power supply will drop less than 2%, and the PCB traces will drop another 1%. This leaves 2% for the AAT4651 as the PC card switch. In the PC card application, the maximum allowable current for the

AAT4651 is dominated by voltage regulation rather than by thermal considerations, and is set by either the current limit or the maximum R_{DS} of the P-channel MOSFET. The maximum R_{DS} at 85°C is calculated by applying the R_{DS} Tempco to the maximum room temperature R_{DS} :

$$R_{DS(MAX)} = R_{DS25} \times (1 + (TC \times \Delta T)), \text{ or}$$

$$R_{DS(MAX)} = 100m\Omega \times (1 + (0.0028 \times 60)) = 116.8m\Omega$$

The maximum current is equal to the 2% tolerance of the 5 volt supply (100mV) across the AAT4651 divided by $R_{DS(MAX)}$. Or

$$I_{MAX5} = 100mV / 116.8m\Omega = 856.2mA$$

For the 3.3 volt supply in the PC card application, the conditions are a bit relaxed, with the allowable voltage regulation drop equal to 300mV. With a 2% supply, and 1% PCB trace regulation, the PC card switch can have a 200mV drop. So

$$I_{MAX3} = 200mV / 134m\Omega = 1.5A$$

Since 1.5A is the nominal current limit value, the AAT4651 will current limit before I_{MAX3} is reached..

Thermal issues are not a problem in the SO-8 package since Θ_{JA} , the package thermal resistance, is only 120°C/W. At any given ambient temperature (T_A) the maximum package power dissipation can be determined by the following equation:

$$P_{D(MAX)} = [T_{J(MAX)} - T_A] / \Theta_{JA}$$

Constants for the AAT4651 are maximum junction temperature, $T_{J(MAX)} = 125^\circ\text{C}$, and package thermal resistance, $\Theta_{JA} = 120^\circ\text{C/W}$. Worst case conditions are calculated at the maximum operating temperature where $T_A = 85^\circ\text{C}$. Typical conditions are calculated under normal ambient conditions where $T_A = 25^\circ\text{C}$. At $T_A = 85^\circ\text{C}$, $P_{D(MAX)} = 333mW$. At $T_A = 25^\circ\text{C}$, $P_{D(MAX)} = 833mW$.

Maximum current is given by the following equation:

$$I_{OUT(MAX)} = (P_{D(MAX)} / R_{ds})^{1/2}$$

For the AAT4651 at 85°C, $I_{OUT(MAX)} = 1.65A$, a value greater than the internal minimum current limit specification.

Overcurrent and Overtemperature Protection

Because many AAT4651 applications provide power to external devices, it is designed to protect its host device from malfunctions in those peripherals

through slew rate control, current limiting, and thermal limiting. The AAT4651 current limit and thermal limit serve as an immediate and reliable electronic fuse without any increase in R_{DS} for this function. Other solutions such as a poly fuse do not protect the host power supply and system from mishandling, or short circuited peripherals, they will only prevent a fire. The AAT4651 high speed current limit and thermal limit not only prevent fires, they also isolate the power supply and entire system from any activity at the external port, and report a mishap by means of a FAULT signal.

Overcurrent and overtemperature go hand in hand. Once an overcurrent condition exists, the current supplied to the load by the AAT4651 is limited to the overcurrent threshold. This results in a voltage drop across the AAT4651 which causes excess power dissipation and a package temperature increase. As the die begins to heat up, the overtemperature circuit is activated. If the temperature reaches the maximum level, the AAT4651 automatically switches off the P-channel MOSFETs. While they are off, the overtemperature circuit remains active. Once the temperature has cooled by approximately 10°C , the P-channel MOSFETs are switched back on. In this manner, the AAT4651 is thermally cycled on and off until the short circuit is removed. Once the short is removed, normal operation automatically resumes.

To save power, the full high speed overcurrent circuit is not activated until a lower threshold of current (approximately 500mA) is exceeded in the power device. When the load current exceeds this

crude threshold, the AAT4651 quiescent current increases from $15\mu\text{A}$ to $200\mu\text{A}$. The high speed overcurrent circuit works by linearly limiting the current when the current limit is reached. As the voltage begins to drop on V_{CC} due to current limiting, the current limit magnitude varies, and generally decreases as the V_{CC} voltage drops to 0 volts.

Switching Vcc Voltage

The AAT4651 meets PC card standards for switching the V_{CC} output by providing a ground path for V_{CC} as well as "off" state. The PC card protocol for determining low voltage operations is to first power the peripheral with 5 volts and poll for 3.3 volt operation. When transitioning from 5 volts to 3.3 volts, V_{CC} must be discharged to less than 0.8 volts to provide a hard reset. The resistive ground state ($V_{CCD0}=V_{CCD1}$) will accommodate this. The ground state will also guarantee the V_{CC} voltage to be discharged within the specified 100ms amount of time.

Printed Circuit Board Layout Recommendations

For proper thermal management, to minimize PCB trace resistance, and to take advantage of the low $R_{DS(ON)}$ of the AAT4651, a few circuit board layout rules should be followed: V_{CC3} , V_{CC5} , and V_{CC} should be routed using wider than normal traces, the two V_{CC} pins (6 and 7) should be connected to the same wide PCB trace, and GND should be connected to a ground plane. For best performance, C_{IN} and C_{OUT} should be placed close to the package pins.

Typical PC Card Application Circuit

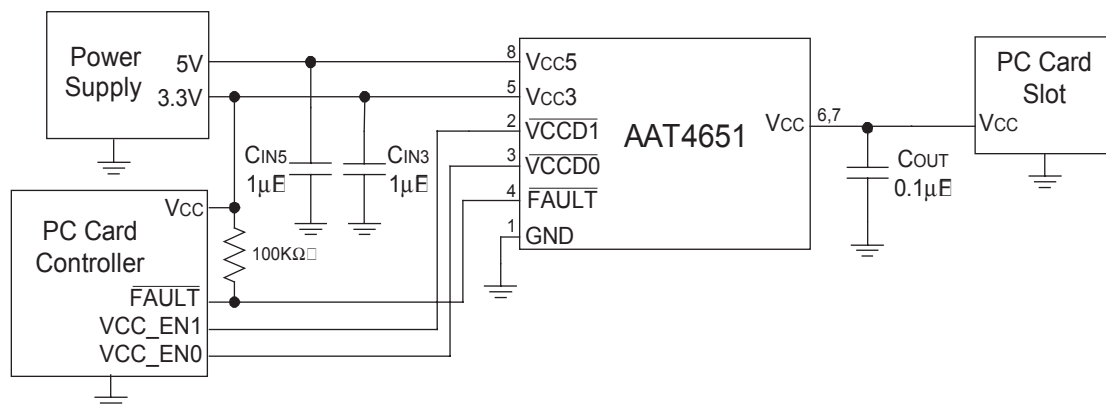

Evaluation Board Layout

The AAT4651 evaluation layout follows the printed circuit board layout recommendations, and can be used for good applications layout.

Note: Board layout shown is not to scale.

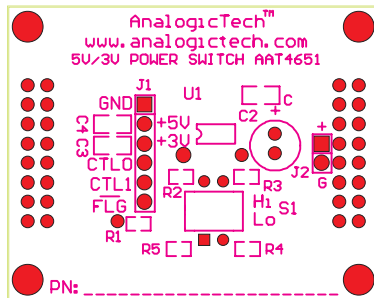

Figure 2: Evaluation board top side silk screen layout / assembly drawing

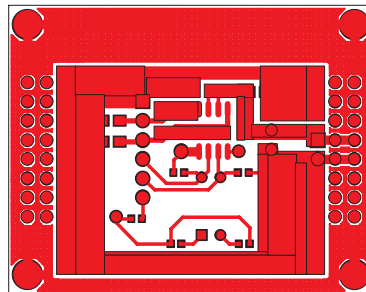

Figure 3: Evaluation board component side layout

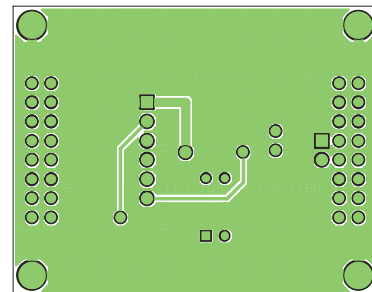

Figure 4: Evaluation board solder side layout

Ordering Information

| Package | Marking | Part Number (Tape and Reel) |
|---------|---------|-----------------------------|
| SOP-8 | 4651 | AAT4651IAS-T1 |
| TSSOP-8 | 4651 | AAT4651IHS-T1 |

Note: Sample stock is generally held on all part numbers listed in **BOLD**.

Package Information

SOP-8

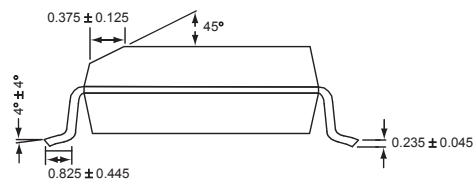
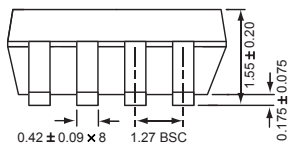
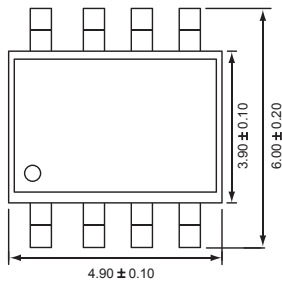

All dimensions in millimeters.

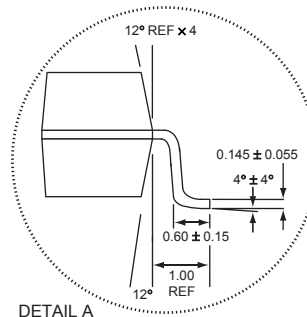
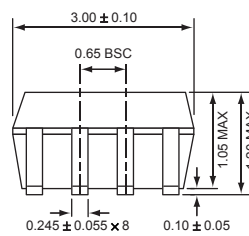
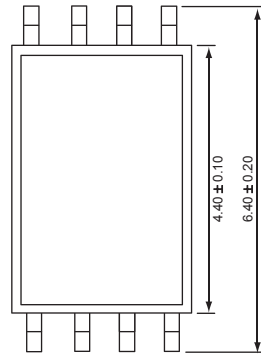
TSSOP-8

DETAIL A

All dimensions in millimeters.

AnalogicTech cannot assume responsibility for use of any circuitry other than circuitry entirely embodied in an AnalogicTech product. No circuit patent licenses, copyrights, mask work rights, or other intellectual property rights are implied.

AnalogicTech reserves the right to make changes to their products or specifications or to discontinue any product or service without notice, and advise customers to obtain the latest version of relevant information to verify, before placing orders, that information being relied on is current and complete. All products are sold subject to the terms and conditions of sale supplied at the time of order acknowledgement, including those pertaining to warranty, patent infringement, and limitation of liability.

AnalogicTech warrants performance of its semiconductor products to the specifications applicable at the time of sale in accordance with AnalogicTech's standard warranty. Testing and other quality control techniques are utilized to the extent AnalogicTech deems necessary to support this warranty. Specific testing of all parameters of each device is not necessarily performed.

Advanced Analogic Technologies, Inc.
 830 E. Arques Avenue, Sunnyvale, CA 94085
 Phone (408) 737-4600
 Fax (408) 737-4611