

12-Dot LED Display Driver

IR2431/IR2432/IR2433

IR2431/IR2432/IR2433

12-Dot LED Display Driver

Description

The IR2431/IR2432/IR2433 is suitable for driving 12 LED level meters.

The IR2433 is cascadable for 144 dots of bar graphic display.

Features

1. LED current can be set by an external resistor
2. IR2431 is a log-scale driver
IR2432 is a VU meter scale driver
IR2433 is a linear-scale driver
3. Cascaded connection is possible for IR2433
4. 22-pin dual-in-line package

Pin Connections

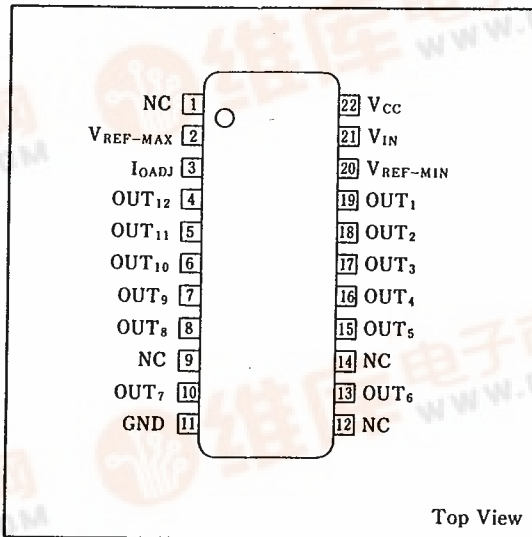

Block Diagram

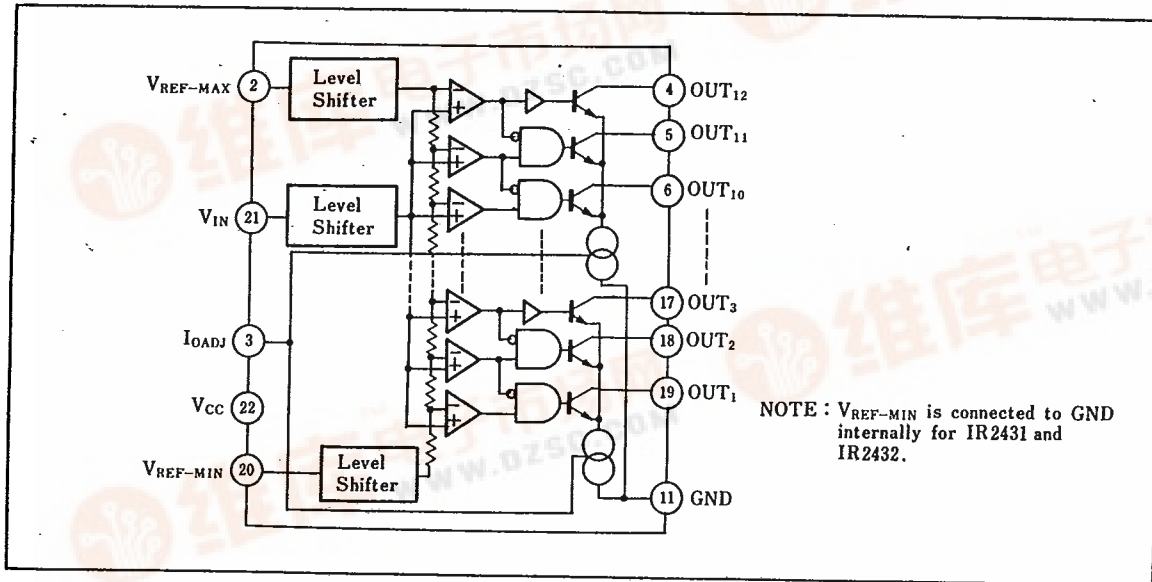

SHARP

12-Dot LED Display Driver

IR2431/IR2432/IR2433

Absolute Maximum Ratings

Parameter	Symbol	Condition	Rating	Unit
Supply voltage	V _{CC}		18	V
Input voltage	V _{IN}	V _{CC} < 10V	10	V
Reference voltage	V _{REF-MAX}	V _{CC} < 10V	10	V
	V _{REF-MIN}		10	
Power dissipation	P _D	T _a ≤ 25°C	1,000	mW
P _D derating ratio	ΔP _D /°C	T _a > 25°C	10	mW/°C
Operating temperature	T _{OPR}		-20 ~ +75	°C
Storage temperature	T _{STG}		-25 ~ +125	°C

Electrical Characteristics

(V_{CC} = 12V, T_a = 25°C)

Parameter	Symbol	Condition	MIN.	TYP.	MAX.	Unit
Operating supply voltage	V _{CC}		8	12	16	V
Supply current	I _{CC}			4	6	mA
Operating reference voltage	V _{REF-MAX}	V _{CC} - V _{REF-MAX} ≥ 2.5V IR2431	5.5		6.0	V
		IR2432	0.6	0.8	1.6	
		V _{CC} - V _{REF-MAX} ≥ 2.5V IR2433	0.5		6.0	
Input current	I _{IN}	Take the current flowing into IC for positive.	-1			μA
	I _{REF-MAX}		-1			
	I _{REF-MIN}	Applies to IR2433			1	
Output current	I _{OUT}	V _{IN} = 6.5V, R _O = 96kΩ	7.5	10	12.5	mA
Output leakage current	I _{OL}				10	μA

Description of Operation

With V_{REF-MAX} and V_{REF-MIN} (IR2431 and IR2432 are connected inside to the GND) given, the reference voltage is 12-divided by the resistance ratio. This is compared with the V_{IN} in each of the comparator circuits to cause the output "High" or "Low" in the AND gate to turn the corresponding transistor on and the LED will glow.

Basic Connection Diagram

(Example GL112R9 Series)

Apply the power supply voltage across the V_{CC}-GND and apply to V_{REF-MAX} and V_{REF-MIN} their reference voltage (IR2431, IR2432 and V_{REF-MIN} are connected inside to the GND). Apply the input voltage to V_{IN}. The current to flow through the LED, I_{LED} can be altered by varying R_O.

The current I_{LED} can be given by the following equation.

$$I_{LED} = 90 \times \frac{V_{CC} - 1.3}{R_O + 1} \text{ (mA)}$$

V_{CC}: V, R_O: kΩ

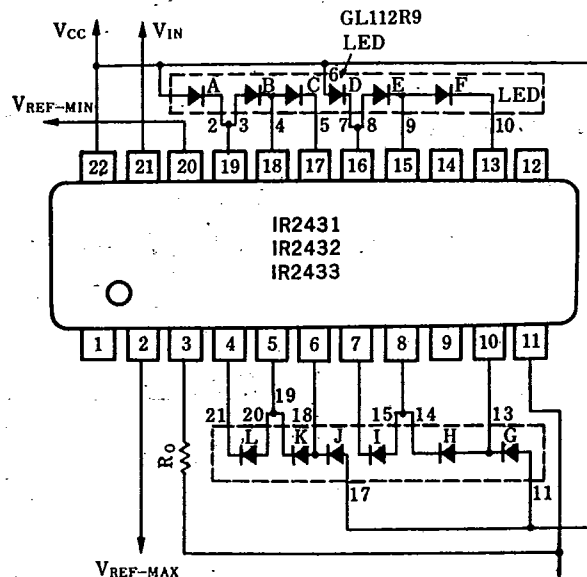

12-Dot LED Display Driver

IR2431/IR2432/IR2433

■ Comparator Level
IR2431, IR2432

		(Unit: dB)											
Model	LED	A	B	C	D	E	F	G	H	I	J	K	L
IR2431		-44	-40	-36	-32	-28	-24	-20	-16	-12	-8	-4	0
IR2432		-20	-15	-10	-7	-4	-2	-1	0	+1	+2	+3	+6

IR2433

As V_{IN} is increased from 0V, the bar type LEDs light up in order. The input level at which the n-th LED lights up can be nearly represented by the following formula.

$$V_n = n \frac{V_{REF-MAX} - V_{REF-MIN}}{12} + V_{REF-MIN}$$

■ Example of IR2433 Circuit Application

(1) 2-chip cascaded

V_{CC} , V_{IN} , $V_{REF-MIN}$, $V_{REF-MAX}$ and BND are connected as shown in the right Fig.

By selecting $R_1 = R_2$, $V_{REF-MAX} - V_{REF-MIN}$ can be divided into 24 equal voltage.

Also, the desired division is possible provided that R_1 and R_2 satisfy the following formula.

$$\frac{V_{REF-MAX} - V_{REF-MIN}}{R_1 + R_2} > 100 \text{ } (\mu A)$$

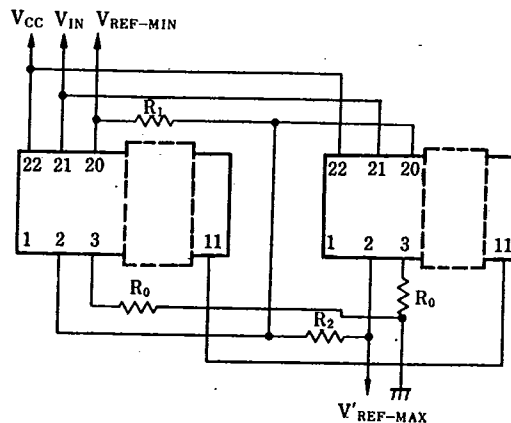

For the connection, refer to the typical connection diagram.

(2) 3~12-chip cascaded

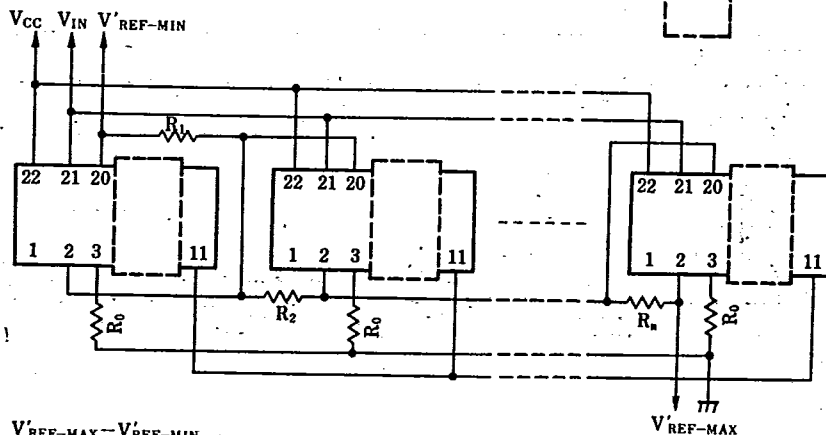

$$\frac{V_{REF-MAX} - V_{REF-MIN}}{\sum R_i} > (n-1) \times 100 \text{ } (\mu A)$$

(i=1,2,...,n)

