

9097247 TOSHIBA. ELECTRONIC

02E 17046 D

TA7292P
TA7293P

T-74-05-01

5.8W DUAL AUDIO POWER AMPLIFIER.
22W BTL AUDIO POWER AMPLIFIER.

The TA7292P/TA7293P are dual audio power amplifier for consumer applications. It is designed for high power, low distortion and low noise. It also contains various kind of protectors. It is suitable for car-audio power amplifier with high performance. The kinds of pin configuration are Available: Normal (TA7292P) and Reverse (TA7293P) for easier layout design of PC-board when used in BTL-stereo application.

• High Power

- POUT(1)=22W(TYP.)
(VCC=14.4V, f=1kHz, THD=10%, RL=4Ω, BTL)
- POUT(2)=19W(TYP.)
(VCC=13.2V, f=1kHz, THD=10%, RL=4Ω, BTL)
- POUT(3)=15W(TYP.)
(VCC=13.2V, f=1kHz, THD=1%, RL=4Ω, BTL)
- POUT(4)=5.8W(TYP.)/ch
(VCC=13.2V, f=1kHz, THD=10%, RL=4Ω, DUAL)

• Low Distortion

- THD(1)=0.03%(TYP.)
(VCC=13.2V, f=1kHz, POUT=4W, RL=4Ω, Gv=40dB, BTL)
- THD(2)=0.06%(TYP.)
(VCC=13.2V, f=1kHz, POUT=1W, RL=4Ω, Gv=52dB, DUAL)

• Low Noise

- VNO(1)=0.14mVrms(TYP.)
(VCC=13.2V, RL=4Ω, Gv=40dB, Rg=0, DIN Noise:DIN45405)
- VNO(2)=0.7mVrms(TYP.)
(VCC=13.2V, RL=4Ω, Gv=52dB, Rg=10kΩ, BW=20Hz~20kHz, DUAL)

• Protector Circuit

Thermal Shut Down, Over Voltage Protection.
Out-VCC Short, Out-GND Short and Out-Out Short Protection.

• Operating Supply Voltage Range

VCC(opr.)=9~18V

Unit in mm

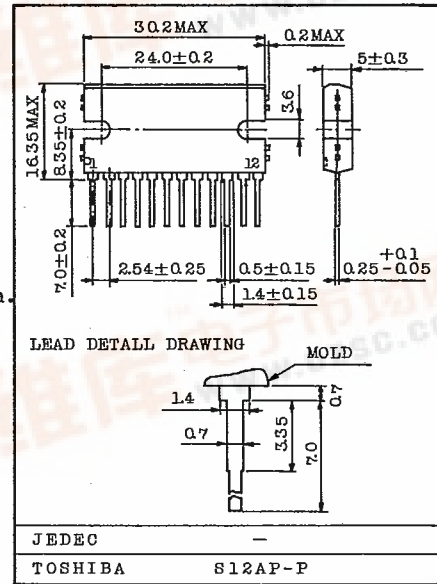

Weight : 7.9g (TYP.)

AUDIO LINEAR IC



9097247 TOSHIBA. ELECTRONIC

02E 17047 D

TA7292P
TA7293P

T-74-05-01

MAXIMUM RATINGS (Ta=25°C)

CHARACTERISTIC	SYMBOL	RATING	UNIT
Peak Supply Voltage (0.2 sec)	VCC surge	45	V
DC Supply Voltage	VCC DC	25	V
Operating Supply Voltage	VCC opr	18	V
Output Current (peak)	IO(peak)	4.5	A
Power Dissipation	PD	25	W
Operating Temperature	Topr	-30~85	°C
Storage Temperature	Tstg	-55~150	°C

ELECTRICAL CHARACTERISTICS

(Unless otherwise specified, VCC=13.2V, RL=4Ω, Rg=600Ω, f=1kHz, Ta=25°C)

CHARACTERISTIC	SYMBOL	TEST CIR-CUIT	TEST CONDITION	MIN.	TYP.	MAX.	UNIT
Quiescent Current	ICQ	2	VIN=0	-	80	145	mA
BTL CONNECTION MODE	Output Power	POUT(1)	1 VCC=14.4V, THD=10%	-	22	-	W
		POUT(2)	1 THD=10%	16	19	-	
		POUT(3)	1 THD=1%	12	15	-	
		THD(1)	1 POUT=4W, Gv=40dB	-	0.03	0.25	
Output Offset Voltage	VOFF	1	VIN=0	-	0	0.35	V
Voltage Gain	Gv(1)	1	VOUT=0dBm	-	40	-	dB
Output Noise Voltage	VNO(1)	1	Rg=0 DIN45405 Noise Filter	-	0.14	-	mVrms
Ripple Rejection Ratio	R.R(1)	1	fripple=100Hz Vripple=0dBm	-	-52	-40	dB
DUAL MODE	Output Power	POUT(4)	2 THD=10%	5	5.8	-	W
	Total Harmonic Distortion	THD(2)	2 POUT=1W	-	0.06	0.30	%
	Voltage Gain	Gv(2)	2 VOUT=0dBm	50	52	54	dB
	Voltage Gain Ratio	ΔGv	2 VOUT=0dBm	-1	0	1	dB
	Output Noise Voltage	VNO(2)	2 Rg=10kΩ BW=20Hz-20kHz	-	0.7	1.5	mVrms
	Ripple Rejection Ratio	R.R(2)	2 fripple=100Hz Vripple=0dBm	-	-52	-40	dB
	Cross Talk	C.T	2 VOUT=0dBm	-	-57	-	dB
Input Resistance	RIN	2 f=1kHz	-	33	-	kΩ	

TOSHIBA

TA7292P
TA7293P
T-74-05-01

TEST CIRCUIT/APPLICATION CIRCUIT

TA7292P

(1) BTL

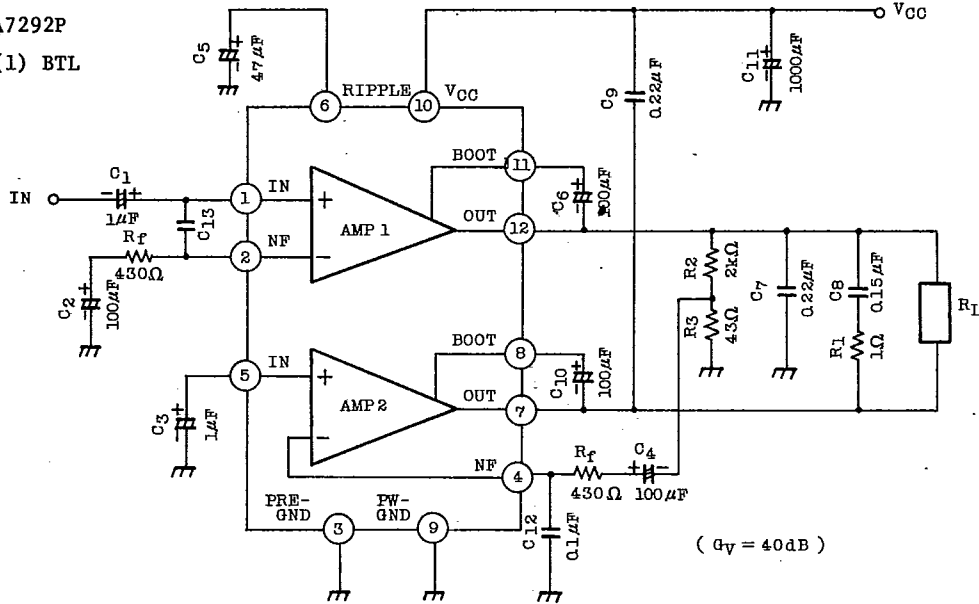

(2) DUAL

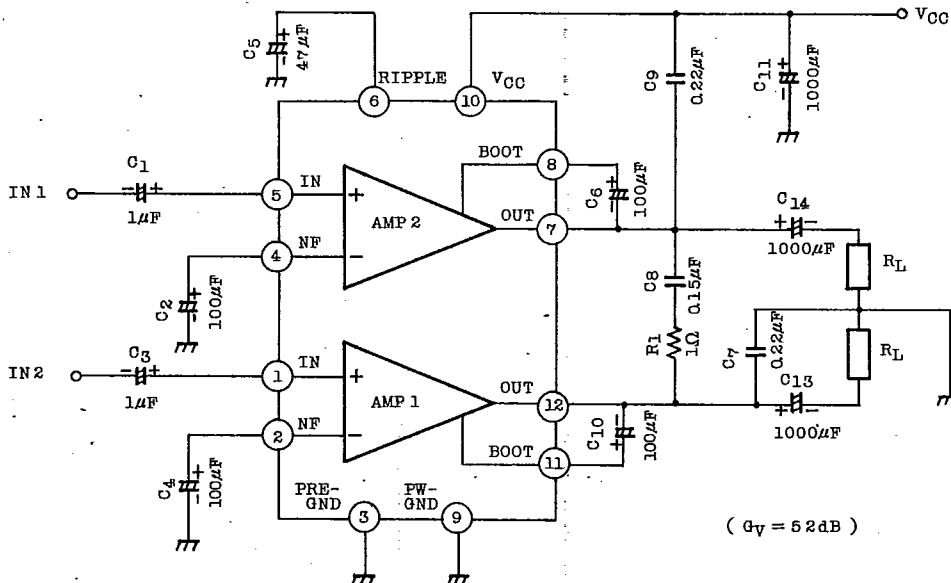

TA7292P
TA7293P

T-74-05-01

TA7293P

(1) BTL

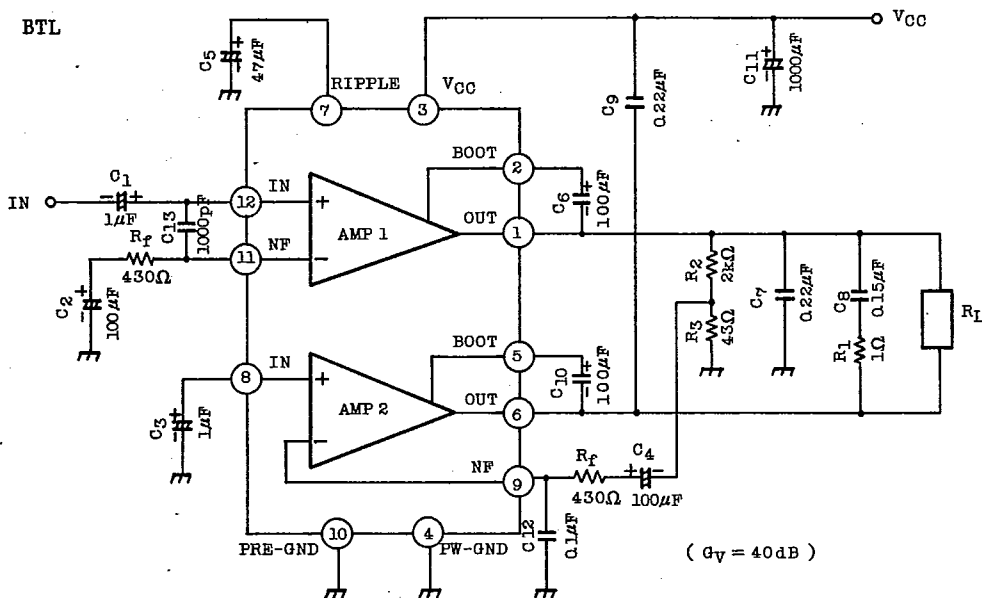

(2) DUAL

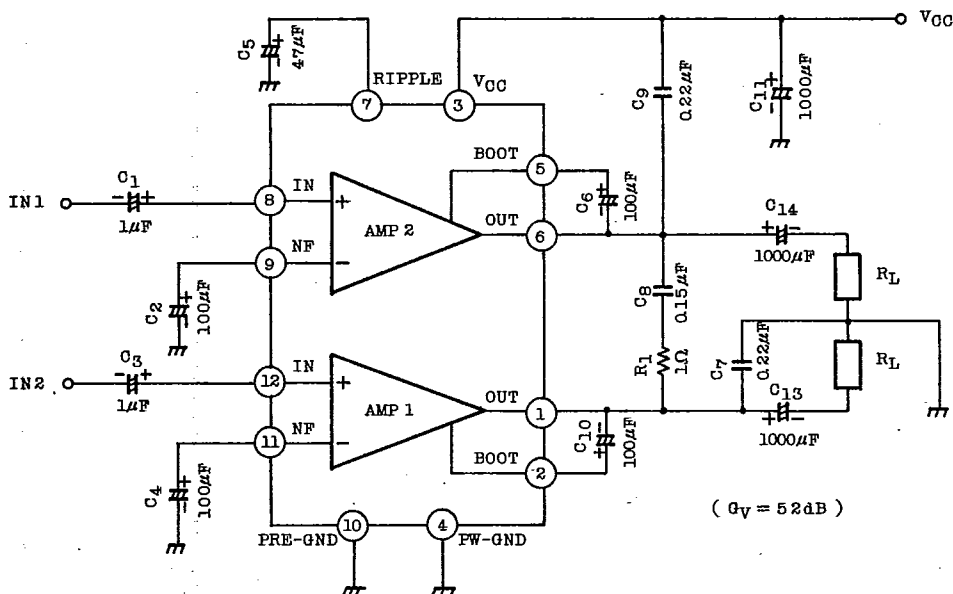

TA7292P TA7293P

T-74-05-01

TYPICAL DC VOLTAGE OF EACH TERMINAL
(V_{CC}=13.2V, T_a=25°C, DUAL MODE CIRCUIT)

TERMINAL No.		1	2	3	4	5	6	7	8	9	10	11	12
DC VOLTAGE (V)	TA7292P	1.5	1.5	GND	1.5	1.5	6.4	6.4	12.3	GND	V _{CC}	12.3	6.4
	TA7293P	6.4	12.3	V _{CC}	GND	12.3	6.4	6.4	1.5	1.5	GND	1.5	1.5

APPLICATION INFORMATION

(This explanatory terminal number is for TA7292P)

1. VOLTAGE GAIN ADJUSTMENT

(1) DUAL AMPLIFIER

The voltage gain G_v is determined by R₁, R₂ and R_f in Fig. 1.

$$G_v = 20 \log \frac{R_f + R_1 + R_2}{R_f + R_1} \quad (\text{dB})$$

In case of R_f=0

The voltage gain is set as follows:

$$G_v = 52 \text{dB (TYP.)}$$

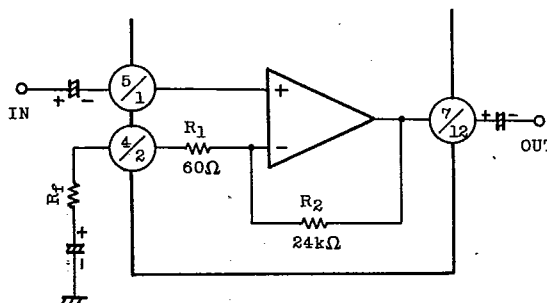

Fig. 1

(2) BTL AMPLIFIER

The recommended BTL connection amplifier shown in Fig. 2.

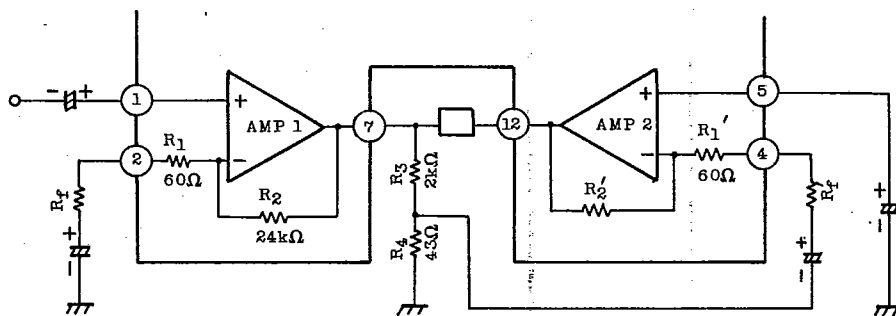

Fig. 2

TA7292P
TA7293P

T-74-05-01

AMP. 1 is noninverting amplifier and AMP. 2 is invert one.
The output voltage is divided by resistors R3 and R4.
The divided voltage is applied to inverting input of AMP. 2.
R3 and R4 are determined in the following equation.

$$\frac{R3+R4}{R3} = 20 \log \frac{Rf+R1+R2}{Rf+R1} \quad (\text{dB}) \quad Gv \text{ in Dual Mode}$$

The voltage gain in this circuit is 6dB higher than that in Dual Mode.

$$Gv = 20 \log \frac{Rf+R1+R2}{Rf+R1} + 6 \quad (\text{dB})$$

In case of $Rf=0$
 $Gv=52+6=58(\text{dB})$

In case of $Rf=430$
 $Gv=34+6=40(\text{dB})$

Each voltage gain can be set as shown above.

2. MUTING

Audio muting can be accomplished by connecting pin 6 (ripple filter) to GND as shown in Fig. 3.

Then, the bias circuits are cut off.

However, caution must be exercised to the following items.

- (1) The recovery time from the muting operation is determined by the capacities of the ripple filter capacitor between 6 pin and GND, and of the capacitor for NF.
- (2) As this muting system is operated by the short-circuit of ripple filter: C5, the ripple rejection ratio becomes worse in the muting condition.
At mute ON, some pop noises of breaking the bias are produced.

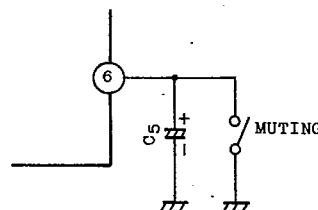

TA7292P
TA7293P

T-74-05-01

The output waveform at muting ON/OFF during BTL, are shown in Fig. 4.
(Provided $V_{CC}=13.2V$, $R_L=4\Omega$, non-signal.)
50dB or more can be obtained for muting amount.

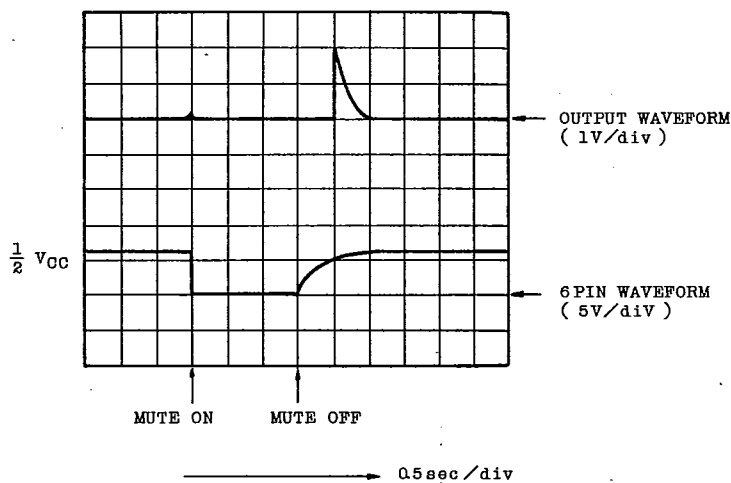

$V_{CC}=13.2V$, $R_L=4\Omega$, INPUT SHORT, BTL

Fig. 4

3. MEASURES AGAINST OSCILLATION

C7, C8, C9, C12 : The capacitor of polyester film having small variation of the temperature characteristics is recommended as the capacitor for oscillation prevention.

C13 : Reduces the gain in the high range frequency (150kHz or over) and increases the oscillation allowance.

R1 : Increases the oscillation allowance at output clipping of the low range frequency (100Hz or less).

Since the oscillation allowance varies according to the following items, carry out the temperature test to confirm the oscillation allowance.

1. Gain to be used (Gv setting).
2. Capacity of capacitor
3. Kinds of capacitor
4. Layout of printed board

TA7292P
TA7293P

T-74-05-01

It is recommended to use the capacitor having the capacity exceeding the oscillation stopping value.

At using with the voltage gain G_v lowered or with the high range frequency and the oscillation becomes liable to be produced.

Therefore, application with $G_v=40\text{dB}$ or over is advisable.

Especially for using with the gain lowered in DUAL operation, insert 1000pF between NF (2 pin and 4 pin) and GND.

This capacitor reduces the gain of the high range frequency and is effective for oscillation prevention.

4. OUTPUT WAVEFORM AT POWER SUPPLY ON/OFF

BTL and dual Amplifier DC output waveforms in the condition of $V_{CC}=13.2\text{V}$, $R_L=4\Omega$ at non-signal (input short) are shown in Fig. 5 and 6.

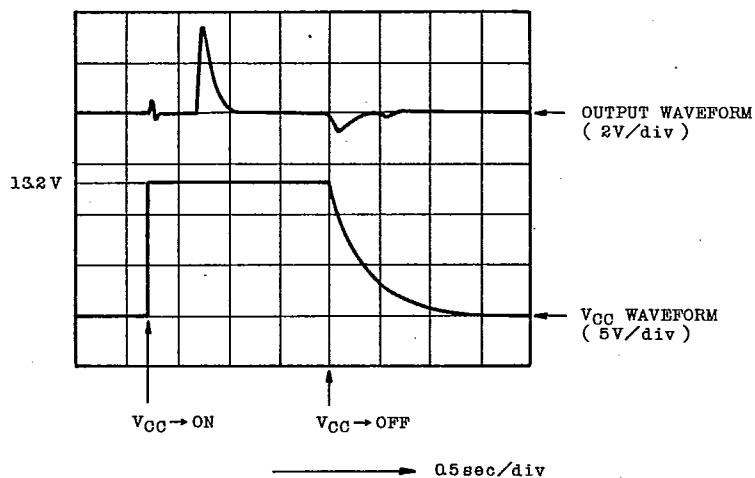

Fig. 5 BTL OPERATION

TA7292P
TA7293P

T-74-05-01

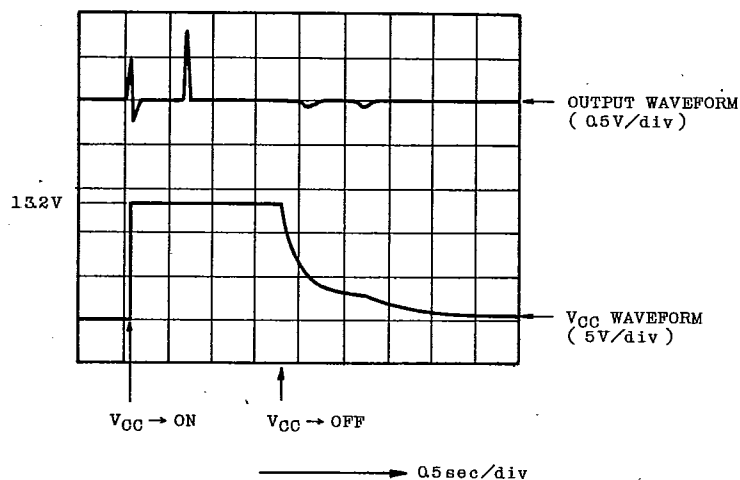

Fig. 6 DUAL OPERATION

The popping time at power supply ON/OFF varies according to the rise and fall times.

The condition in which the power supply is rapidly and repeatedly made ON/OFF, that is, the condition in which the charge is made on the external capacitor of IC is different from the conditions shown in Fig. 5 and Fig. 6.

9097247 TOSHIBA, ELECTRONIC

02E 17055 D

TA7292P
TA7293P

T-74-05-01

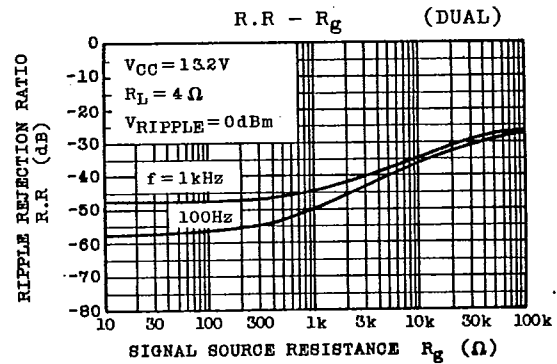
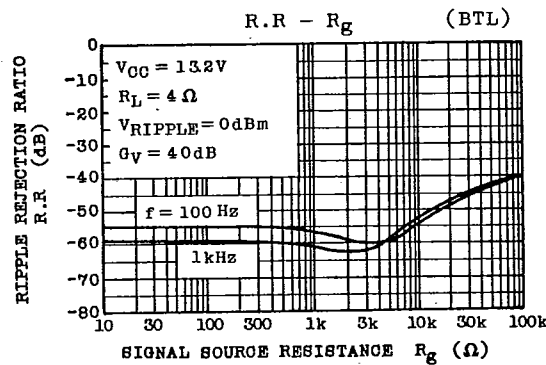
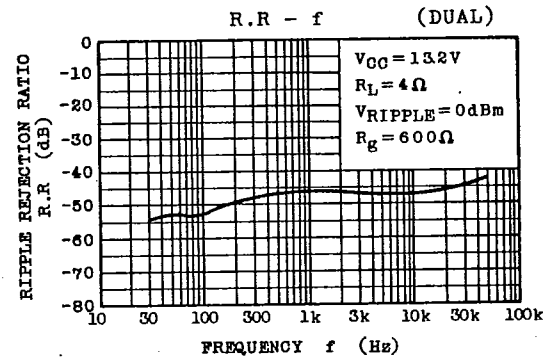
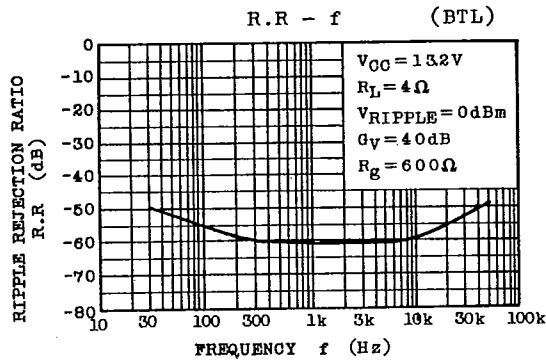
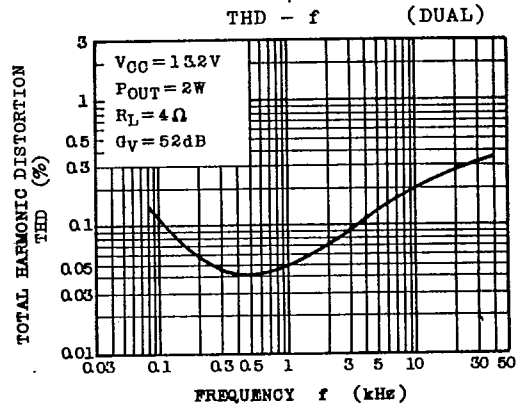
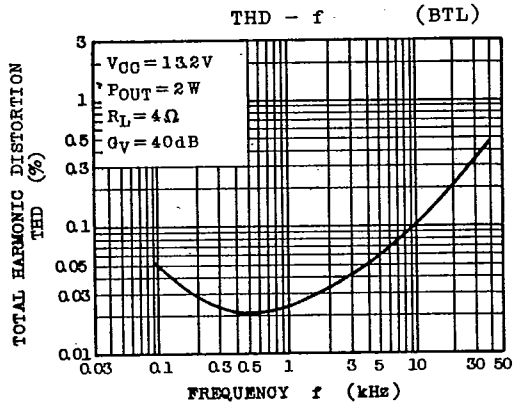

9097247 TOSHIBA, ELECTRONIC

02E 17056 D

TA7292P TA7293P

T-74-05-01

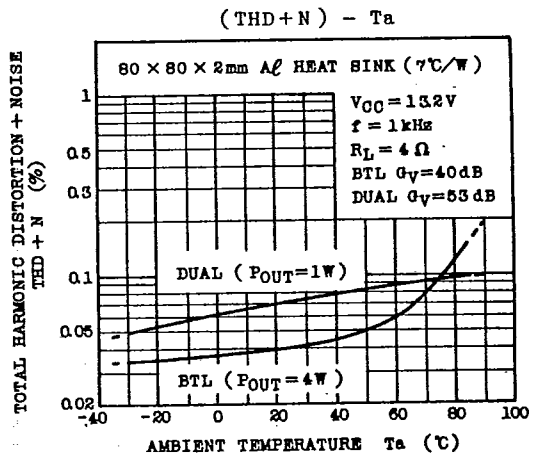
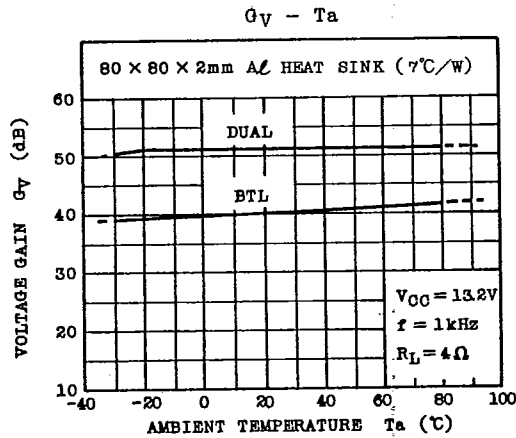
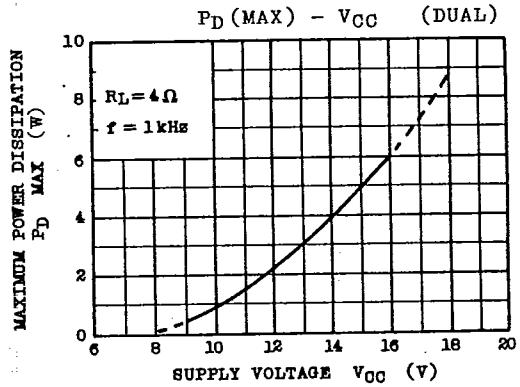
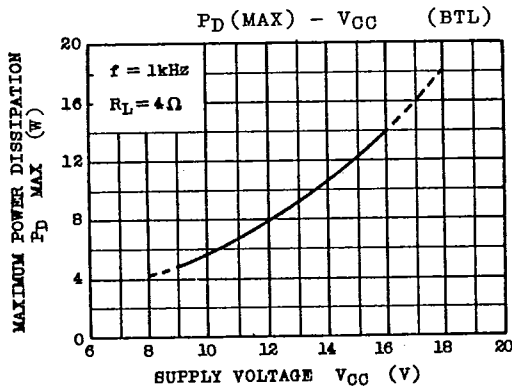
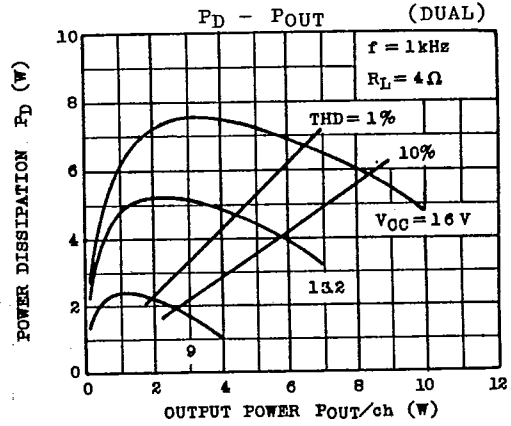
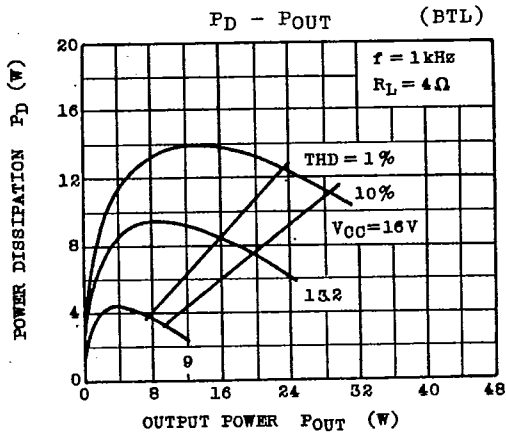

AUDIO LINEAR IC

TA7292P
TA7293P

T-74-05-01

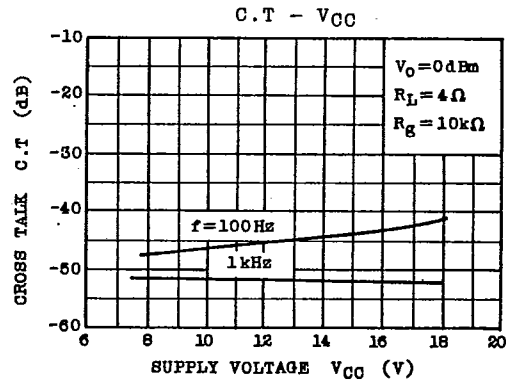
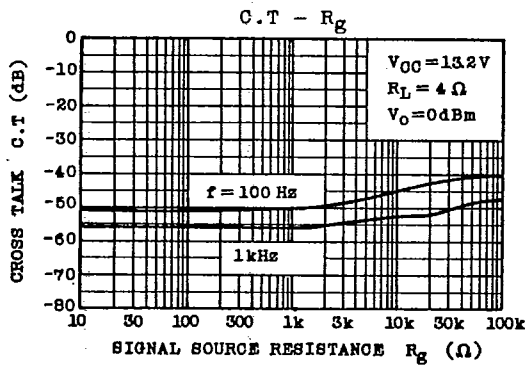
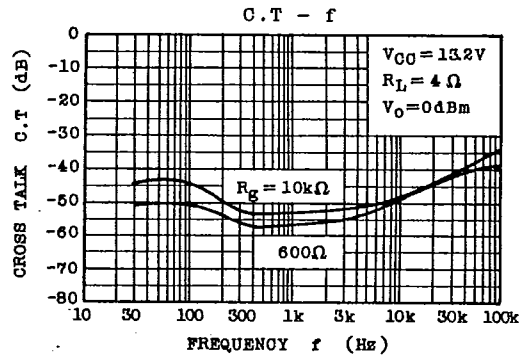
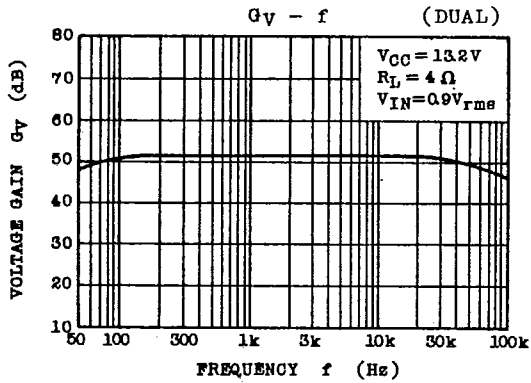
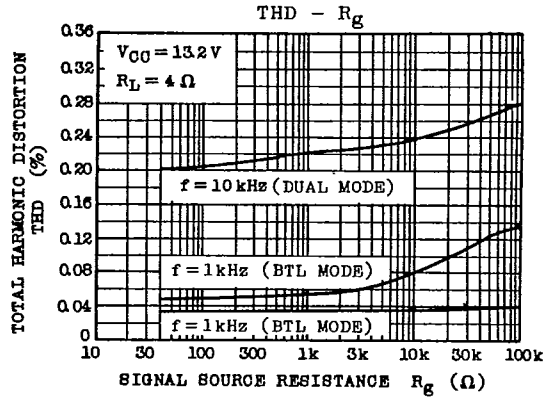
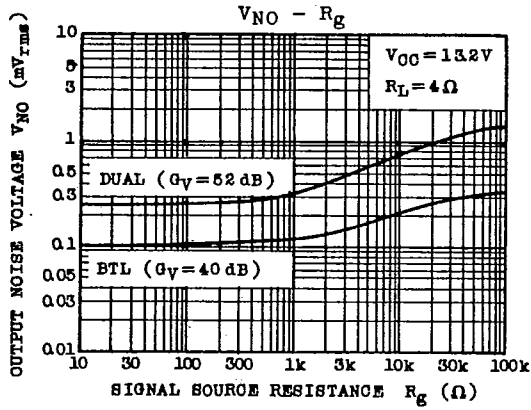

9097247 TOSHIBA, ELECTRONIC

02E 17058 D

TA7292P
TA7293P

T-74-05-01

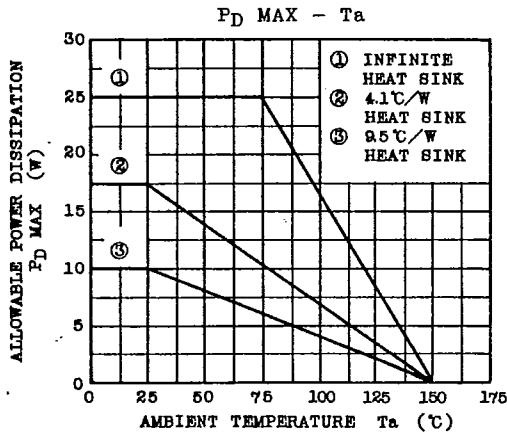
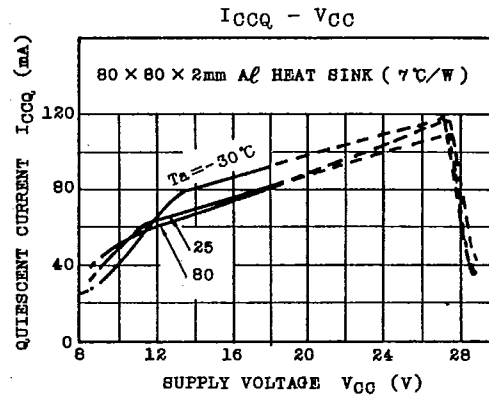
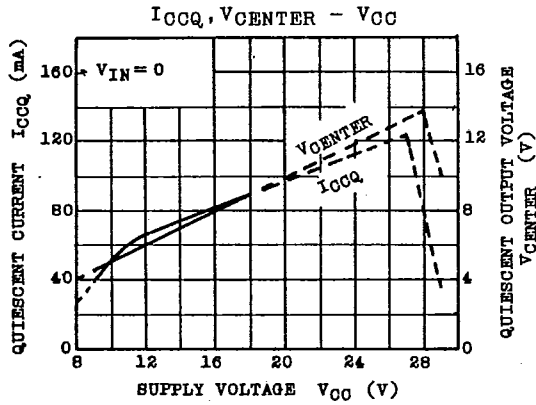

AUDIO LINEAR IC