



UTRON

Rev. 1.4

UT6264C

8K X 8 BIT LOW POWER CMOS SRAM

REVISION HISTORY

REVISION	DESCRIPTION	Date
Preliminary Rev. 0.1	Original.	May 3 ,2001
Rev. 1.0	Revised - The timing waveforms add CE2 control pin	Jun.4,2001
Rev. 1.1	Revised - Package outline dimension - Waveform.	Jan 15,2002
Rev. 1.2	Revised - Improve I _{DR} from 20μA to 10μA (LL-version , max.) - 28-pin PDIP package outline dimension	May 14,2002
Rev. 1.3	1. Add Extended temperature : -20 ~85 2. Revised Operating : 45/30 mA (typ.)→40/30 mA (typ.) 3. Revised CMOS Standby : 2→0.3mA (typ.) normal 4. Revised DC characteristics : a. I _{cc} (-35) : 45→40mA (typ.), 60→50 mA (max) b. I _{cc} (-70) : 45→40mA (max.) c. I _{cc} 1(Tcycle=1us)= 10mA(max.) d. I _{cc} 2(Tcycle=500ns)=20mA(max.) 5. Revised "Order information" : add Extended parts	Jul 30,2002
Rev. 1.4	Add order information for lead free product	May 15,2003





FEATURES

- Access time : 35/70ns (max.)
- Low power consumption :
Operating : 40/30 mA (typ.)
CMOS Standby : 0.3mA (typ.) normal
2 μ A (typ.) L-version
1 μ A (typ.) LL-version
- Single 4.5V~5.5V power supply
- Operating temperature :
Commercial : 0 ~70
Extended : -20 ~85
- All inputs and outputs TTL compatible
- Fully static operation
- Three state outputs
- Data retention voltage : 2V (min.)
- Package : 28-pin 600 mil PDIP
28-pin 330 mil SOP

FUNCTIONAL BLOCK DIAGRAM

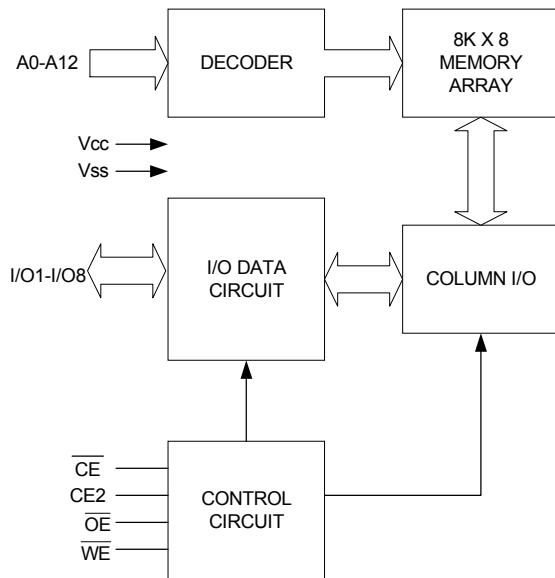

GENERAL DESCRIPTION

The UT6264C is a 65,536-bit low power CMOS static random access memory organized as 8,192 words by 8 bits. It is fabricated using high performance, high reliability CMOS technology.

Easy memory expansion is provided by using two chip enable input.(\overline{CE} ,CE2),and supports low data retention voltage for battery back-up operation with low data retention current.

The UT6264C operates from a single 4.5V~5.5V power supply and all inputs and outputs are fully TTL compatible.

PIN CONFIGURATION

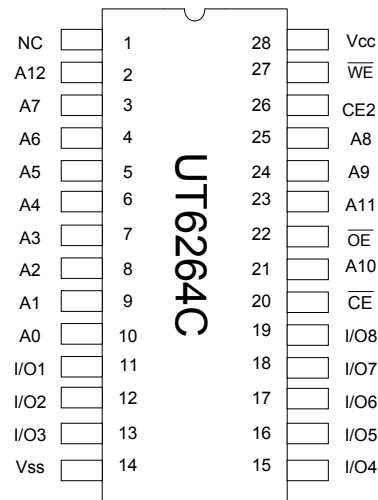

PDIP/SOP

PIN DESCRIPTION

SYMBOL	DESCRIPTION
A0 - A12	Address Inputs
I/O1 - I/O8	Data Inputs/Outputs
\overline{CE} ,CE2	Chip Enable Inputs
\overline{WE}	Write Enable Input
\overline{OE}	Output Enable Input
V _{CC}	Power Supply
V _{SS}	Ground
NC	No connection



UTRON

UT6264C

Rev. 1.4

8K X 8 BIT LOW POWER CMOS SRAM

ABSOLUTE MAXIMUM RATINGS*

PARAMETER	SYMBOL	RATING	UNIT
Terminal Voltage with Respect to V _{SS}	V _{TERM}	-0.5 to 7.0	V
Operating Temperature	Commercial	TA	0 to 70
	Extended	TA	-20 to 85
Storage Temperature	T _{STG}	-65 to 150	
Power Dissipation	P _D	1	W
DC Output Current	I _{OUT}	50	mA
Soldering Temperature (under 10 sec)	T _{solder}	260	

*Stresses greater than those listed under "Absolute Maximum Ratings" may cause permanent damage to the device. This is a stress rating only and functional operation of the device or any other conditions above those indicated in the operational sections of this specification is not implied. Exposure to the absolute maximum rating conditions for extended period may affect device reliability.

TRUTH TABLE

MODE	\overline{CE}	CE2	\overline{OE}	\overline{WE}	I/O OPERATION	SUPPLY CURRENT
Standby	H	X	X	X	High - Z	ISB, ISB1
Standby	X	L	X	X	High - Z	ISB, ISB1
Output Disable	L	H	H	H	High - Z	I _{CC} , I _{CC1} , I _{CC2}
Read	L	H	L	H	D _{OUT}	I _{CC} , I _{CC1} , I _{CC2}
Write	L	H	X	L	D _{IN}	I _{CC} , I _{CC1} , I _{CC2}

note: H = V_{IH}, L = V_{IL}, X = Don't care.

DC ELECTRICAL CHARACTERISTICS (V_{CC} = 4.5V~5.5V, T_A = 0 to 70 / -20 to 85 (E))

PARAMETER	SYMBOL	TEST CONDITION	MIN.	TYP.	MAX.	UNIT	
Input High Voltage	V _{IH} ^{*1}		2.2	-	V _{CC} +0.5	V	
Input Low Voltage	V _{IL} ^{*2}		- 0.5	-	0.8	V	
Input Leakage Current	I _{LI}	V _{SS} V _{IN} V _{CC}	- 1	-	1	μA	
Output Leakage Current	I _{LO}	V _{SS} V _{I/O} V _{CC} ; \overline{CE} = V _{IH} ; or CE2 = V _{IL} ; or \overline{OE} = V _{IH} ; or \overline{WE} = V _{IL}	- 1	-	1	μA	
Output High Voltage	V _{OH}	I _{OH} = -1mA	2.4	-	-	V	
Output Low Voltage	V _{OL}	I _{OL} = 4mA	-	-	0.4	V	
Operating Power Supply Current	I _{CC}	\overline{CE} = V _{IL} , I _{I/O} = 0mA, Cycle=Min.	- 35	-	40	50	mA
			- 70	-	30	40	mA
	I _{CC1}	\overline{CE} = 0.2V; I _{I/O} = 0mA; CE2 = V _{CC} -0.2V; other pins at 0.2V or V _{CC} -0.2V	T _{cycle} = 1μs	-	-	10	mA
I _{CC2}		T _{cycle} = 500ns	-	-	20	mA	
Standby Power Supply Current	I _{SB}	\overline{CE} = V _{IH} or CE2 = V _{IL}	normal	-	1	10	mA
	I _{SB1}	\overline{CE} V _{CC} -0.2V or CE2 0.2V		0.3	5	mA	
	I _{SB}	\overline{CE} = V _{IH} or CE2 = V _{IL}	-L/-LL	-	-	3	mA
	I _{SB1}	\overline{CE} V _{CC} -0.2V or CE2 0.2V	-L	-	2	100	μA
-LL			-	1	50	μA	

Notes:

1. Overshoot : V_{CC}+2.0v for pulse width less than 10ns.
2. Undershoot : V_{SS}-2.0v for pulse width less than 10ns.
3. Overshoot and Undershoot are sampled, not 100% tested.



UTRON

Rev. 1.4

UT6264C

8K X 8 BIT LOW POWER CMOS SRAM

CAPACITANCE ($T_A=25$, $f=1.0\text{MHz}$)

PARAMETER	SYMBOL	MIN.	MAX	UNIT
Input Capacitance	C_{IN}	-	8	pF
Input/Output Capacitance	$C_{I/O}$	-	10	pF

Note : These parameters are guaranteed by device characterization, but not production tested.

AC TEST CONDITIONS

Input Pulse Levels	0V to 3.0V
Input Rise and Fall Times	5ns
Input and Output Timing Reference Levels	1.5V
Output Load	$C_L = 100\text{pF}$, $I_{OH}/I_{OL} = -1\text{mA}/4\text{mA}$

AC ELECTRICAL CHARACTERISTICS ($V_{CC} = 4.5\text{V}\sim 5.5\text{V}$, $T_A = 0$ to 70 / -20 to 85 (E))

(1) READ CYCLE

PARAMETER	SYMBOL	UT6264C-35		UT6264C-70		UNIT
		MIN.	MAX.	MIN.	MAX.	
Read Cycle Time	t_{RC}	35	-	70	-	ns
Address Access Time	t_{AA}	-	35	-	70	ns
Chip Enable Access Time	t_{ACE}	-	35	-	70	ns
Output Enable Access Time	t_{OE}	-	25	-	35	ns
Chip Enable to Output in Low-Z	t_{CLZ}^*	10	-	10	-	ns
Output Enable to Output in Low-Z	t_{OLZ}^*	5	-	5	-	ns
Chip Disable to Output in High-Z	t_{CHZ}^*	-	25	-	35	ns
Output Disable to Output in High-Z	t_{OHZ}^*	-	25	-	35	ns
Output Hold from Address Change	t_{OH}	5	-	5	-	ns

(2) WRITE CYCLE

PARAMETER	SYMBOL	UT6264C-35		UT6264C-70		UNIT
		MIN.	MAX.	MIN.	MAX.	
Write Cycle Time	t_{WC}	35	-	70	-	ns
Address Valid to End of Write	t_{AW}	30	-	60	-	ns
Chip Enable to End of Write	t_{CW}	30	-	60	-	ns
Address Set-up Time	t_{AS}	0	-	0	-	ns
Write Pulse Width	t_{WP}	25	-	50	-	ns
Write Recovery Time	t_{WR}	0	-	0	-	ns
Data to Write Time Overlap	t_{DW}	20	-	30	-	ns
Data Hold from End of Write-Time	t_{DH}	0	-	0	-	ns
Output Active from End of Write	t_{OW}^*	5	-	5	-	ns
Write to Output in High-Z	t_{WHZ}^*	-	15	-	25	ns

*These parameters are guaranteed by device characterization, but not production tested.



TIMING WAVEFORMS

READ CYCLE 1 (Address Controlled) (1,2)

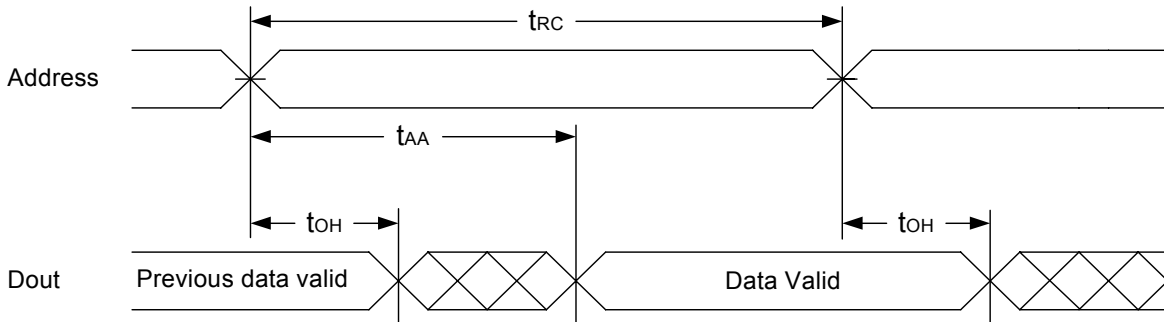

READ CYCLE 2 (\overline{CE} and CE2 and \overline{OE} Controlled) (1,3,4,5)

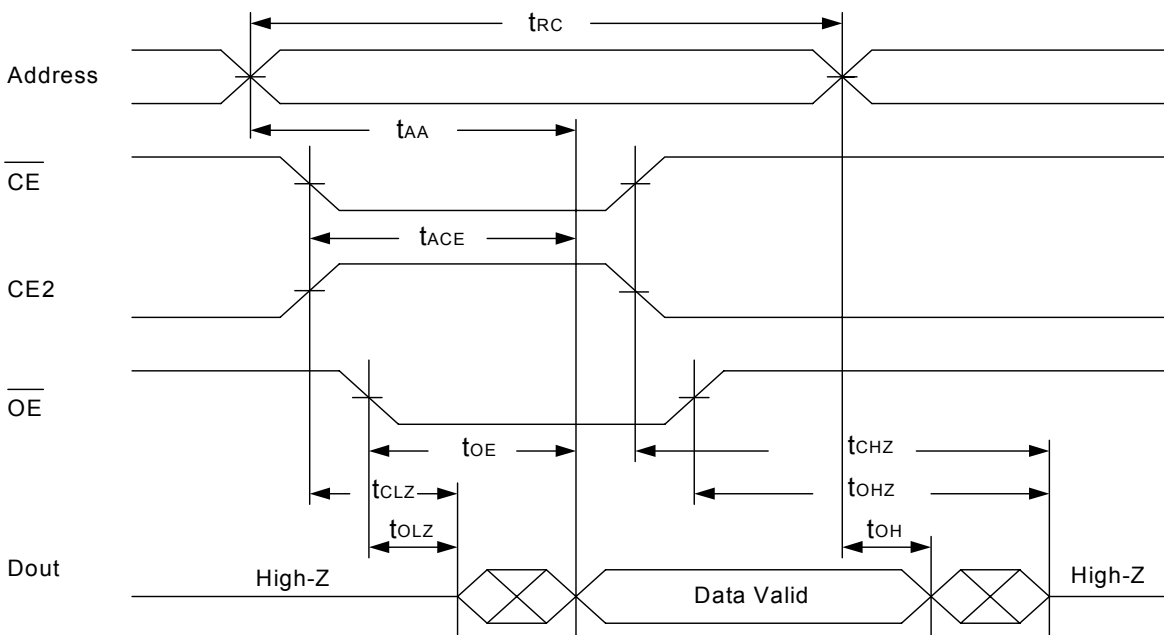

Notes :

1. \overline{WE} is high for read cycle.
2. Device is continuously selected \overline{OE} =low, \overline{CE} =low, CE2=high.
3. Address must be valid prior to or coincident with \overline{CE} =low, CE2=high; otherwise t_{AA} is the limiting parameter.
4. t_{CLZ} , t_{OLZ} , t_{CHZ} and t_{OHZ} are specified with $C_L=5pF$. Transition is measured $\pm 500mV$ from steady state.
5. At any given temperature and voltage condition, t_{CHZ} is less than t_{CLZ} , t_{OHZ} is less than t_{OLZ} .



WRITE CYCLE 1 (\overline{WE} Controlled) (1,2,3,5,6)

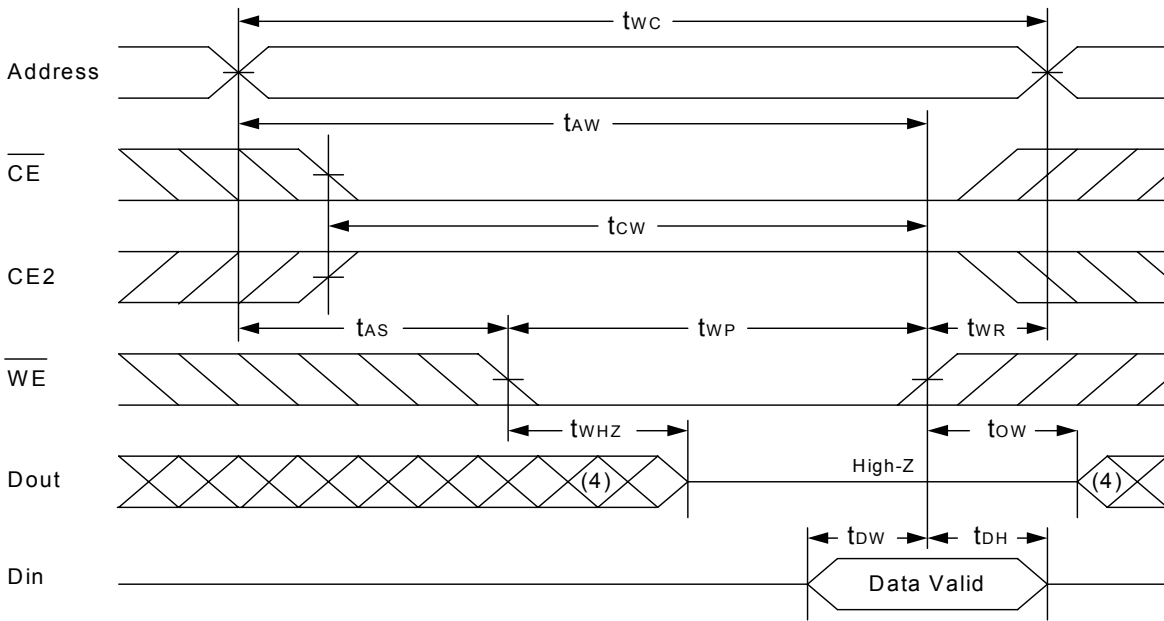

WRITE CYCLE 2 (\overline{CE} and $\overline{CE2}$ Controlled) (1,2,5,6)

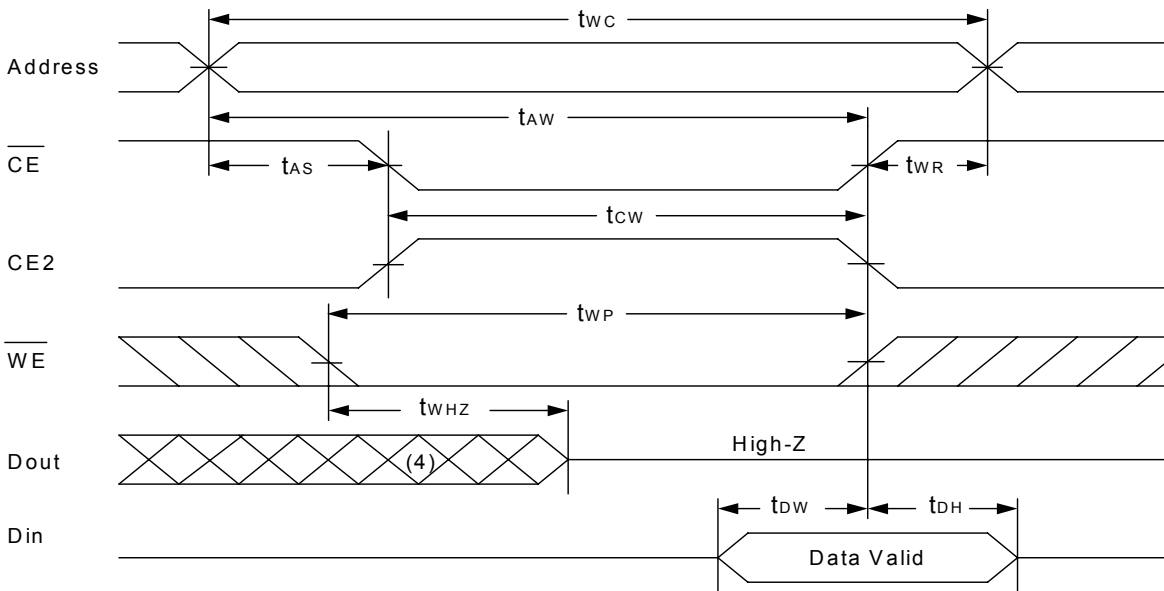



Notes :

1. \overline{WE} , \overline{CE} must be high or $CE2$ must be low during all address transitions.
2. A write occurs during the overlap of a low \overline{CE} , high $CE2$, low \overline{WE} .
3. During a \overline{WE} controlled write cycle with \overline{OE} low, t_{WP} must be greater than $t_{WHZ} + t_{DW}$ to allow the drivers to turn off and data to be placed on the bus.
4. During this period, I/O pins are in the output state, and input signals must not be applied.
5. If the \overline{CE} low transition and $CE2$ high transition occurs simultaneously with or after \overline{WE} low transition, the outputs remain in a high impedance state.
6. t_{LOW} and t_{WHZ} are specified with $C_L = 5pF$. Transition is measured $\pm 500mV$ from steady state.

DATA RETENTION CHARACTERISTICS ($T_A = 0$ to 70 / -20 to 85 (E))

PARAMETER	SYMBOL	TEST CONDITION	MIN.	TYP.	MAX.	UNIT
Vcc for Data Retention	V_{DR}	\overline{CE} $V_{CC}-0.2V$ or $CE2 \leq 0.2V$	2.0	-	5.5	V
Data Retention Current	I_{DR}	$V_{CC}=2V$	-L	1	50	μA
		\overline{CE} $V_{CC}-0.2V$ or $CE2 \leq 0.2V$	-LL	0.5	10	μA
Chip Disable to Data Retention Time	t_{CDR}	See Data Retention Waveforms (below)	0	-	-	ns
Recovery Time	t_R		t_{RC}^*	-	-	ns

t_{RC}^* = Read Cycle Time

DATA RETENTION WAVEFORM

Low Vcc Data Retention Waveform (1) (\overline{CE} controlled)

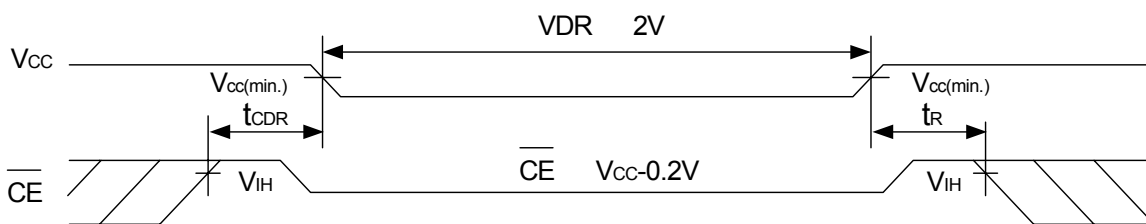

Low Vcc Data Retention Waveform (2) ($CE2$ controlled)

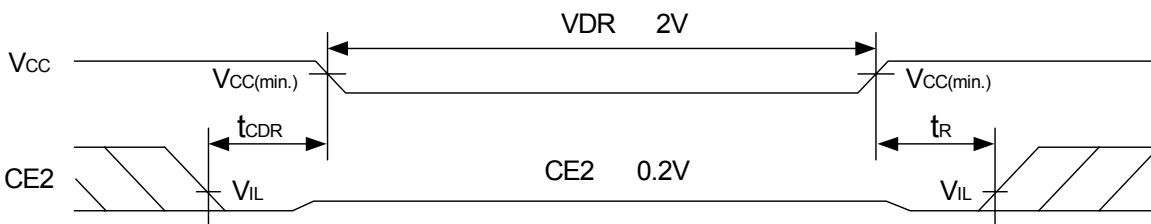



UTRON

Rev. 1.4

UT6264C

8K X 8 BIT LOW POWER CMOS SRAM

PACKAGE OUTLINE DIMENSION

28 pin (600mil) PDIP Package Outline Dimension

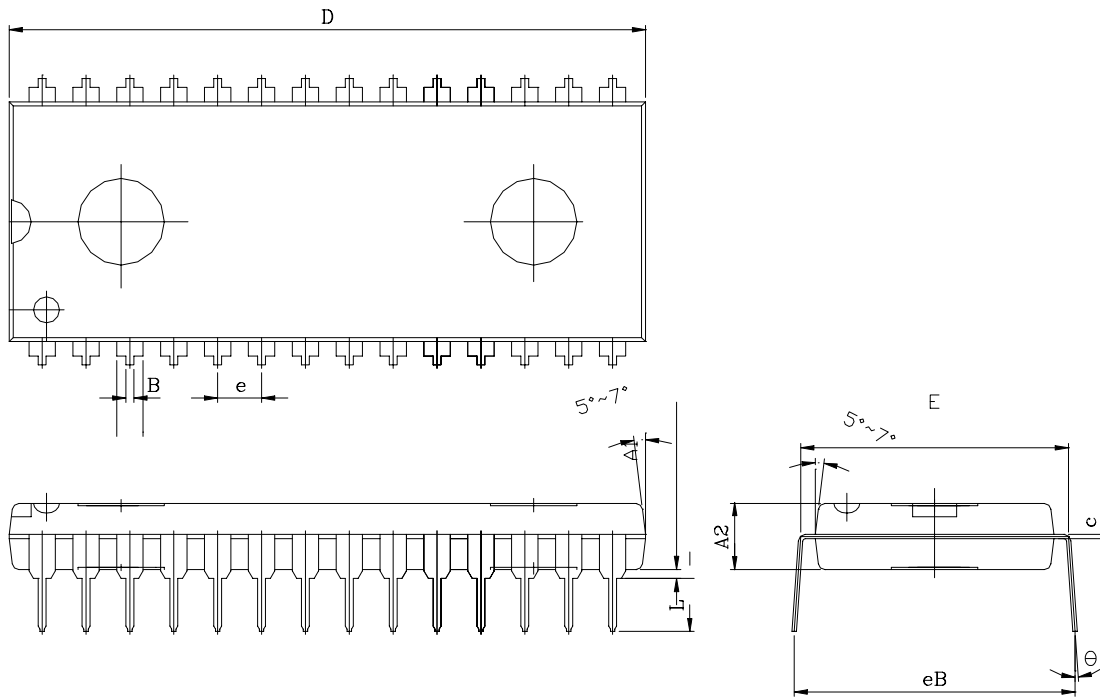

SYMBOL	UNIT	INCH(BASE)	MM(REF)
A1		0.010 (MIN)	0.254 (MIN)
A2		0.150 ± 0.01	3.810 ± 0.254
B		0.018 ± 0.005	0.457 ± 0.127
c		0.010 ± 0.004	0.254 ± 0.102
D		1.460 ± 0.005	37.084 ± 0.127
E		0.600 ± 0.010	15.240 ± 0.254
e		0.100 (TYP)	2.540 (TYP)
eB		0.640± 0.03	16.256 ± 0.762
L		0.130 ± 0.010	3.302 ± 0.254
		0° 15°	0° 15°



UTRON

Rev. 1.4

UT6264C

8K X 8 BIT LOW POWER CMOS SRAM

28 pin 330 mil SOP Package Outline Dimension

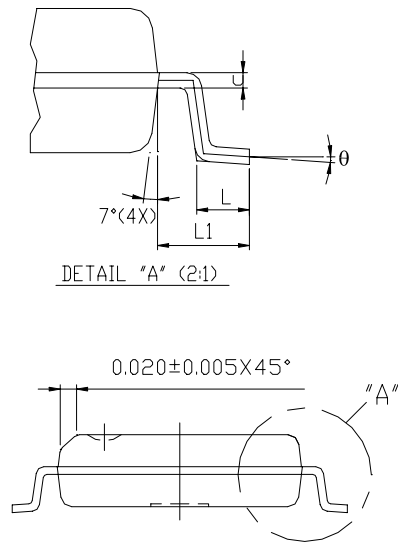
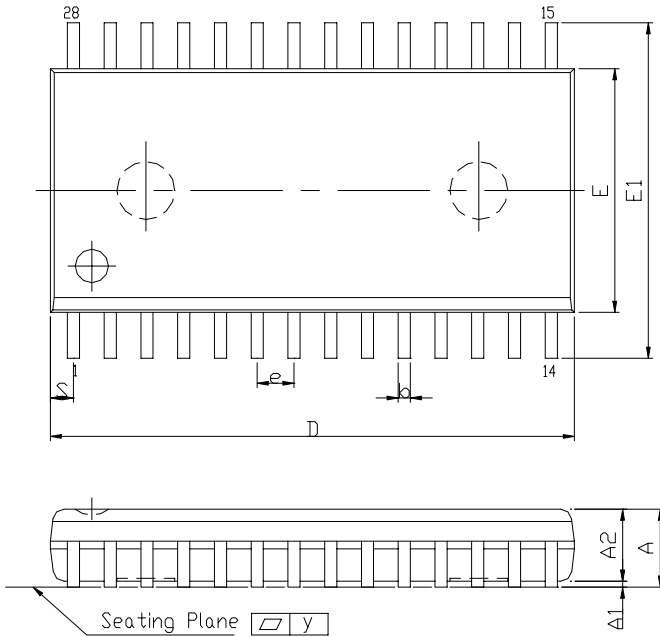

SYMBOL \ UNIT	INCH(BASE)	MM(REF)
A	0.112(max)	2.845(max)
A1	0.004(MIN)	0.102(MIN)
A2	0.098±0.005	2.489±0.127
b	0.016(TYP)	0.406(TYP)
c	0.010(TYP)	0.254(TYP)
D	0.713±0.005	18.110±0.127
E	0.331±0.005	8.407±0.127
E1	0.465±0.012	11.811±0.305
e	0.050(TYP)	1.270(TYP)
L	0.0404±0.008	1.0255±0.203
L1	0.067±0.008	1.702±0.203
S	0.047(MAX)	1.194(MAX)
y	0.003(MAX)	0.076(MAX)
θ	0°~10°	0°~10°



UTRON

Rev. 1.4

UT6264C

8K X 8 BIT LOW POWER CMOS SRAM

ORDERING INFORMATION

Commerical temperature

PART NO.	ACCESS TIME (ns)	STANDBY CURRENT (μ A) (TYP.)	PACKAGE
UT6264CPC-35	35	0.3mA	28 PIN PDIP
UT6264CPC-35L	35	2 μ A	28 PIN PDIP
UT6264CPC-35LL	35	1 μ A	28 PIN PDIP
UT6264CPC-70	70	0.3mA	28 PIN PDIP
UT6264CPC-70L	70	2 μ A	28 PIN PDIP
UT6264CPC-70LL	70	1 μ A	28 PIN PDIP
UT6264CSC-35	35	0.3mA	28 PIN SOP
UT6264CSC-35L	35	2 μ A	28 PIN SOP
UT6264CSC-35LL	35	1 μ A	28 PIN SOP
UT6264CSC-70	70	0.3mA	28 PIN SOP
UT6264CSC-70L	70	2 μ A	28 PIN SOP
UT6264CSC-70LL	70	1 μ A	28 PIN SOP

Extended temperature

PART NO.	ACCESS TIME (ns)	STANDBY CURRENT (μ A) (TYP.)	PACKAGE
UT6264CPC-35E	35	0.3mA	28 PIN PDIP
UT6264CPC-35LE	35	2 μ A	28 PIN PDIP
UT6264CPC-35LLE	35	1 μ A	28 PIN PDIP
UT6264CPC-70E	70	0.3mA	28 PIN PDIP
UT6264CPC-70LE	70	2 μ A	28 PIN PDIP
UT6264CPC-70LLE	70	1 μ A	28 PIN PDIP
UT6264CSC-35E	35	0.3mA	28 PIN SOP
UT6264CSC-35LE	35	2 μ A	28 PIN SOP
UT6264CSC-35LLE	35	1 μ A	28 PIN SOP
UT6264CSC-70E	70	0.3mA	28 PIN SOP
UT6264CSC-70LE	70	2 μ A	28 PIN SOP
UT6264CSC-70LLE	70	1 μ A	28 PIN SOP



UTRON

Rev. 1.4

UT6264C

8K X 8 BIT LOW POWER CMOS SRAM

ORDERING INFORMATION (for lead free product)

Commerical temperature

PART NO.	ACCESS TIME (ns)	STANDBY CURRENT (μA) (TYP.)	PACKAGE
UT6264CPCL-35	35	0.3mA	28 PIN PDIP
UT6264CPCL-35L	35	2 μ A	28 PIN PDIP
UT6264CPCL-35LL	35	1 μ A	28 PIN PDIP
UT6264CPCL-70	70	0.3mA	28 PIN PDIP
UT6264CPCL-70L	70	2 μ A	28 PIN PDIP
UT6264CPCL-70LL	70	1 μ A	28 PIN PDIP
UT6264CSCL-35	35	0.3mA	28 PIN SOP
UT6264CSCL-35L	35	2 μ A	28 PIN SOP
UT6264CSCL-35LL	35	1 μ A	28 PIN SOP
UT6264CSCL-70	70	0.3mA	28 PIN SOP
UT6264CSCL-70L	70	2 μ A	28 PIN SOP
UT6264CSCL-70LL	70	1 μ A	28 PIN SOP

Extended temperature

PART NO.	ACCESS TIME (ns)	STANDBY CURRENT (μA) (TYP.)	PACKAGE
UT6264CPCL-35E	35	0.3mA	28 PIN PDIP
UT6264CPCL-35LE	35	2 μ A	28 PIN PDIP
UT6264CPCL-35LLE	35	1 μ A	28 PIN PDIP
UT6264CPCL-70E	70	0.3mA	28 PIN PDIP
UT6264CPCL-70LE	70	2 μ A	28 PIN PDIP
UT6264CPCL-70LLE	70	1 μ A	28 PIN PDIP
UT6264CSCL-35E	35	0.3mA	28 PIN SOP
UT6264CSCL-35LE	35	2 μ A	28 PIN SOP
UT6264CSCL-35LLE	35	1 μ A	28 PIN SOP
UT6264CSCL-70E	70	0.3mA	28 PIN SOP
UT6264CSCL-70LE	70	2 μ A	28 PIN SOP
UT6264CSCL-70LLE	70	1 μ A	28 PIN SOP



UTRON

Rev. 1.4

UT6264C

8K X 8 BIT LOW POWER CMOS SRAM

THIS PAGE IS LEFT BLANK INTENTIONALLY.