

T-25-01

Maximum Ratings	Symbol	Units	D PACK THYRISTOR (25 mm.)		POWER PACK THYRISTORS (28mm.)						MEGA PACK THYRISTORS (33mm.)					
			D 220	D 510	E, F 180	E, F 220	E, F 300	E, F 400	E, F 500	E, F 600	G 300	G 400	G 500	G 650	G 850	G 950
RMS Forward Current	$I_T(RMS)$	A	330	510	330	370	450	550	600	650	490	600	690	785	850	950
Ave. Forward Current	$I_T(AV)$	A	210	324	210	235	290	350	380	420	310	380	440	500	545	600
Peak One-Cycle Surge @ 8.3 ms	I_{TSM}	kA	4.0	6.0	3.5	3.5	4.5	5.0	6.0	6.5	5.0	6.0	6.5	7.5	8.0	9.5
$I^2 t$ @ 8.3 ms	$I^2 t$	$A^2 \text{ sec.} \times 10^3$	65	150	51	51	85	100	150	175	100	150	175	234	270	375
① Forward Voltage Drop	V_{TM}	V	2.00	1.20	3.00	2.60	2.00	1.50	1.35	1.20	2.60	2.00	1.70	1.50	1.35	1.20
Max. Operating Temperature	T_j	°C	125	125	125	125	125	125	125	125	125	125	125	125	125	125
⑩ Max. Voltage Rating	V_{RRM} V_{DRM}	V	1500	1500	3000	2600	2000	1800	1800	1200	3000	2600	2000	1800	2000	1800
② 3Ø DC Bridge, air cooled	$I_{(DC)}$	A			310	360	470	570	600	680	440	530	620	700	760	830
③ 3Ø Double Wye (I.P.T.), H ₂ O cooled	$I_{(DC)}$	A			1140	1300	1600	1960	2140	2360	1600	1940	2240	2580	2820	3100
④ 1Ø or 3Ø AC Switch, air cooled	$I_{(RMS)}$	A			230	270	350	420	450	500	350	430	500	570	620	680
Characteristics and Ratings																
⑤ *Max. Rate-of-Rise On-State Cur.	di/dt	A/ μ s	200				200									400
Peak Rev. and Fwd. Blocking Current	I_{RRM} I_{DRM}	mA	20				20									35
⑩ Storage Temperature Range	$T_{stg.}$	°C	- 40 +125				- 40 +125									- 40 +125
Max. Holding Current	I_H	mA	200				200									200
Max. Latching Current	I_L	A	1.0				1.0									1.0
⑥ *Min. Critical Rate-of-Rise of Off-State Volt.	dv/dt	V/ μ s			200 (400 TYPICAL)											200
Max. Delay Time	t_d	μ s	2				2									2
⑦ Turn-Off Time (typical)	t_q	μ s	200				200									200
Reverse Recovery Time (typical)	t_{rr}	μ s	12				12									16
Peak Rev. Recovery Current (typical)		A	6				6									8
Max. Ave. Gate Power Dissipation	$P_{G(AV)}$	W	5				5									5
Max. Peak Gate Power Dissipation	P_{GM}	W	20				20									20
Max. Peak Positive Gate Current	I_{GM}	A	4				4									4
⑧ Max. Negative Gate Voltage	V_{GM}	V	5				5									5
⑨ Max. Gate Voltage to Trigger	V_{GT}	V	3.0				3.0									3.0
⑨ Max. Gate Current to Trigger	I_{GT}	mA	225				150									150
Min. Gate Pulse Width to Trigger		μ s	10				10									10
Max. Gate Voltage Not to Trigger	V_{GD}	V	.15				.15									.15
Max. Gate Current Not to Trigger	I_{GD}	mA	10				5									5
Mounting Force	F	kg/lbs	400/800				500/1100									1000/2200
Max. Thermal Resistance J-C (DC)	R_{θ}	°C/W	.08				.09									.06
Max. Thermal Resistance C-Sink (Single Side)	R_{θ}	°C/W	.03				.02									.012
Weight (typical), 1 kg = 2.2 lbs.	W	kg	.0568				.090/.140									.200

(1) V_{TM} @ 2500A Peak for Z and ZD types; V_{TM} @ 500 A Peak for D, E, F, and G types; V_{TM} @ 5000 A Peak for J, JD
 (2) DC output Current using a type 62RLB assembly, ambient temperature = 50°C, air flow = 1000 LFM (5m/sec.)
 (3) DC output Current using a type 62HSW assembly, water temperature = 25°C, water flow = 1.0 GPM (1.06 ltr/sec.)
 (4) AC RMS line Current using a type 22RLA assembly, ambient temperature = 50°C, air flow = 1000 LFM (5m/sec.)
 Higher output ratings are available using larger heatsinks, higher cooling flow rates, one in series with the cooling medium or lower ambient conditions.

Except Z, ZD Types are in a 11 XM Type air cooled heatsink and J, JD Types are in special heatsinks.

PLEASE NOTE: The above summary is only a convenient introduction to the PSI thyristor family. Much more detail is available from the factory on:
 • Paralleling characteristics • Special dv/dt to 1000 V/ μ sec • Reverse recovery characteristics • Welding characteristics
 Please contact the factory or your nearest PSI representatives for more details.

T-01-01
T-25-01

ASTRO PACK THYRISTORS (52mm.)								SPECIAL THYRISTORS				DIODE TYPES											
Z 800	Z 1000	Z 1200	Z 1400	Z 1600	Z 1800	Z 2000	Z 2300	J 1800	J 2200	J 2600	J 3000	FD 600	FD 900	GD 800	GD 1400	ZD 1500	ZD 2100	ZD 2500	ZD 3000	JD 2300	JD 4000	JD 6000	
1085	1280	1550	1860	2050	2170	2400	2900	2120	2420	2875	3345	670	1250	1200	1800	1900	2700	3400	3800	2720	4700	7500	
700	825	1000	1200	1325	1400	1550	1900	1350	1540	1830	2130	430	800	640	1150	1200	1700	2160	2400	1730	3000	4750	
14.0	16.0	18.0	20.0	24.0	26.0	26.0	28.0	28.0	32.0	36.0	42.0	5.5	7.0	10.0	12.0	20.0	25.0	25.0	30.0	35	50	70	
820	1070	1350	1670	2400	2815	2815	3265	3255	4250	5378	7320	125	205	400	600	1670	2600	2600	3740	5084	10375	20335	
2.85	2.30	1.80	1.45	1.25	1.15	1.15	.97	2.45	2.15	1.67	1.30	1.50	1.10	1.20	1.00	1.60	1.00	1.00	.88	2.2	1.14	.84	
125	125	125	125	125	125	150	150	125	125	125	125	150	190	150	190	150	150	190	190	150	150	190	
3000	2600	2000	1800	1400	600	600	200	3000	2600	2200	1400	3000	2000	3000	2000	3000	2000	1200	600	4400	2500	600	
1200	1380	1660	1970	2210	2510	2680	3350	1950	2100	2550	3000	710	1330	1000	1760	2300	3320	4350	4890	2600	4500	7200	
3280	3800	4580	5400	6060	6840	7360	8680	8100	9240	10980	12780	2240	4140	3440	6040	5960	8780	10900	12300	10380	18000	28500	
890	1020	1230	1460	1630	1860	1980	2480	1440	1550	1890	2220	-	-	-	-	-	-	-	-	-	-	-	
400								400				-		-		-		-		-		-	
50								100				40		40		50		100		200			
- 40 +125								- 40 +150				- 40 +150		- 40 +190		- 40 +150		- 40 +190		- 40 +190			
500								500				500		-		-		-		-			
2.0								2.0				2.0		-		-		-		-			
200 (400 TYPICAL)								200 (400 TYPICAL)				-		-		-		-					
2								2				2		-		-		-		-			
300								300				300		-		-		-		-			
20								20				30		12		16		20		30			
10								10				20		6		8		10		20			
10								10				10		-		-		-		-			
30								30				30		-		-		-		-			
5								5				5		-		-		-		-			
5								5				5		-		-		-		-			
3.0								3.0				3.0		-		-		-		-			
300								300				300		-		-		-		-			
10								10				20		-		-		-		-			
.15								.15				.10		-		-		-		-			
5								5				5		-		-		-		-			
2000/4400								2000/4400				6000/13200		500/1100		1000/2200		2000/4400		6000/13200			
.025								.025				.013		.09		.06		.025		.013			
.01								.01				.006		.02		.012		.01		.006			
.430								.430				2.5		.140		.200		.430		2.5			

(5) $V_s \leq 1000V$, $I_{TM} \geq 2 \times I_{T(AV)}$, $T_J = 125^\circ C$, Rep Rate 60 Hz, Gate Drive - see below*

(6) @ Max. T_J , to 80% of rated V_{DRM} , (linear)

(7) $T_J = 125^\circ C$, $I_{TM} = 500A$, $V_R \leq 50V$, $di/dt = -10A/\mu s$, Reapplied Volt. -linear to V_{DRM}

(8) Caution: This could cause triggering and is not recommended

(9) $T_J = 25^\circ C$ $V_D = 9V$

(10) Derate V_{DRM} , V_{RRM} , 10% for Operation below $0^\circ C$.

*Standard Gate Drive: Open Circuit Voltage = 20V, Source Impedance = 10 ohms. Pulse width = 10 μs . Rise Time $\leq 2 \mu s$

T-01-01
T-25-01

STANDARD OPTIONS

The P S I devices specified herein are based on standard devices that have proven most successful in service. Certain options have proven very valuable and are available on most P S I pressure mounted thyristors on special order.

1. Differential Voltage Ratings

On standard devices the voltage rating is determined by the lowest reading of five voltages, i.e. V_{DRM} V_{RRM} @25°C and at 125°C, plus dv/dt . However, there are applications and circuits that place widely different requirements on V_{DRM} , V_{RRM} and dv/dt . Savings can often be realized on such units as shown below:

PRICE RATIO	
A. F400-12	1.0
B. F400-18	1.5
C. F400-12/15/18	1.2

Thyristor A and B are measured by the standard method, while unit C offers V_{RRM} of 1800V, V_{DRM} of 1500V and dv/dt of 100V/usec at 1200V. Thus, the vital V_{RRM} is available at less cost than if all criteria had to be met.

This option is particularly valuable on certain D.C. bridge applications where V_{DRM} and dv/dt are not quite as important as V_{RRM} .

2. Suppression Rating

This refers to the ability of a thyristor to block voltage in the forward direction immediately following surge current. This property is particularly important on protective systems known as "ride through", whereby the equipment phases back to a safe value immediately following a current overload.*

FIG. 1 illustrates this property and a typical specification would read as follows: "from a starting T_j of 100°C device must block V_{DRM} of 1800 volts 4 milliseconds following 16000 amp surge."

For more complete characterization of this property it is necessary that the user supply the following information:

- A. Junction temperature prior to surge
- B. Magnitude and duration of surge
- C. Magnitude of reapplied voltage
- D. Interval between surge and reapplied voltage

*For more details refer to IEEE paper available from P S I.

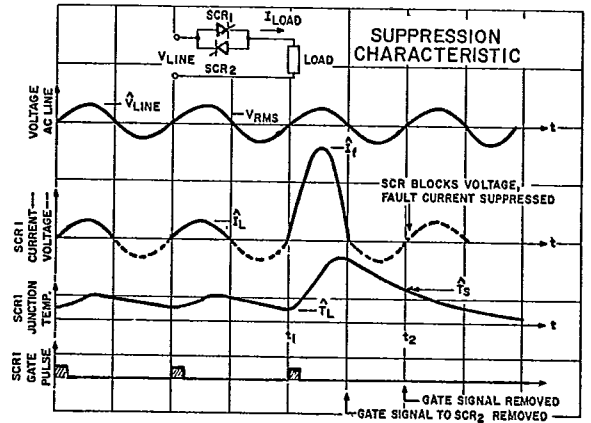
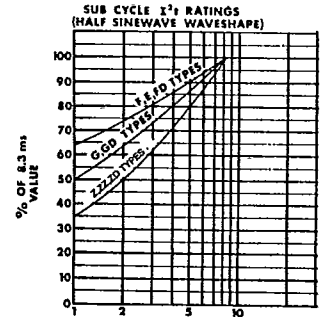
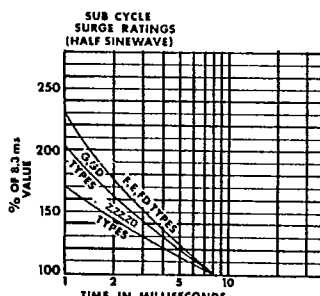
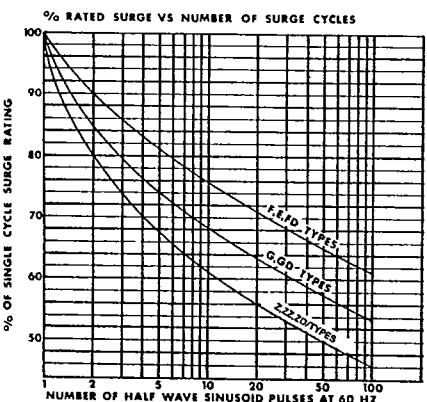

FIG. 1 SUPPRESSION CHARACTERISTICS

GENERAL INFORMATION ON SURGE; I²T



T-01-01
T-25-01

E & F SERIES POWER PACKS (28mm.)

**CASE TEMPERATURE
vs
FORWARD CURRENT**

POWER DISSIPATION

Rectangular Wave Form* – Double Side Cooled

360° or DC CONDUCTION

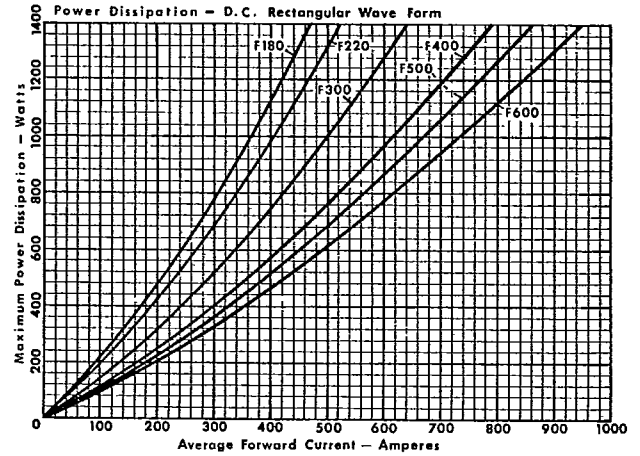
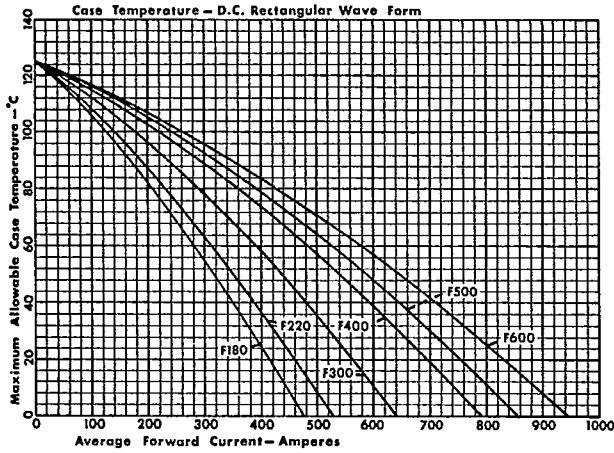

120° CONDUCTION

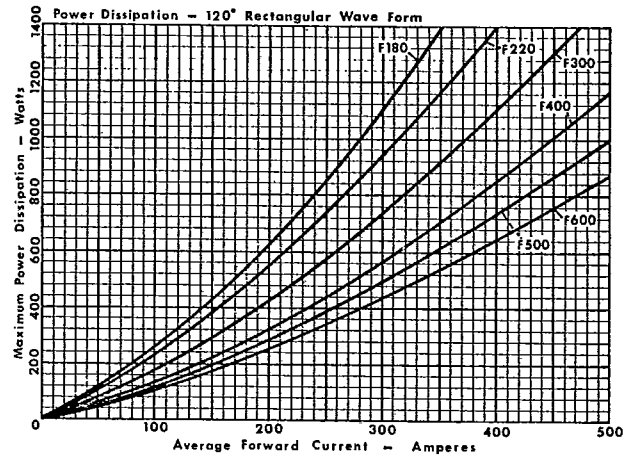
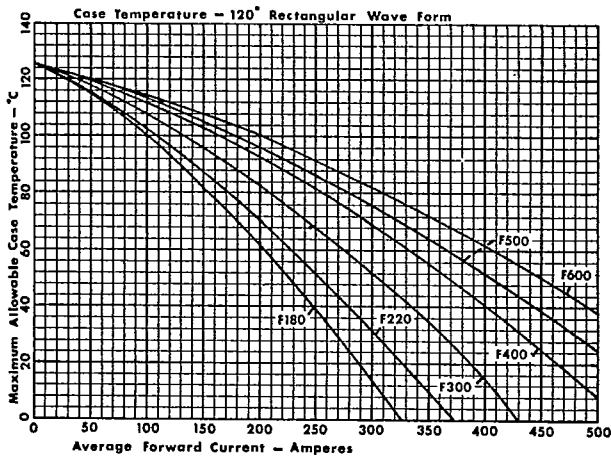

90° CONDUCTION

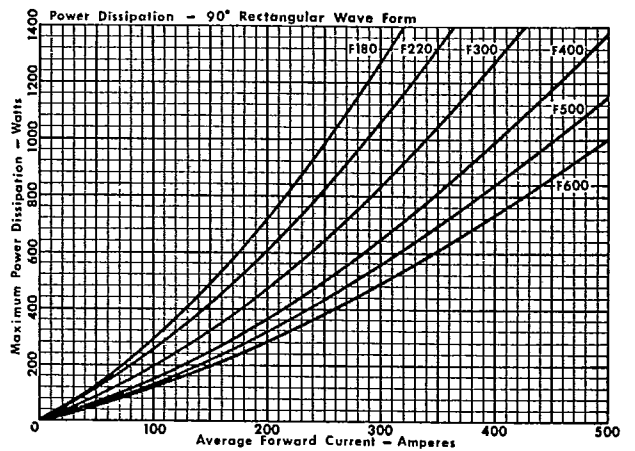
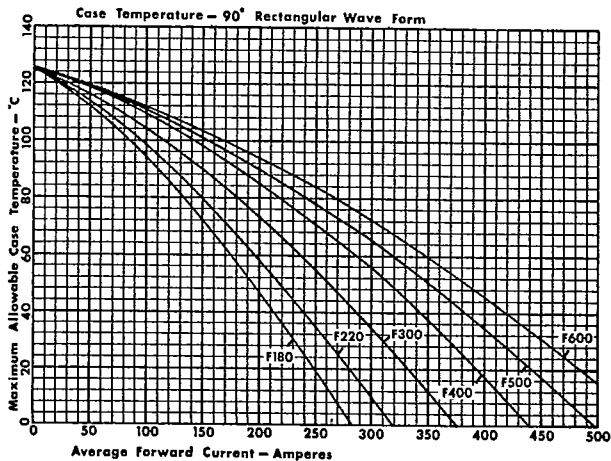

*Use 120° rectangular values for 180° sine wave applications.

T-01-01
T-25-01

E & F SERIES POWER PACKS (28mm.)

**CASE TEMPERATURE
VS
FORWARD CURRENT**

POWER DISSIPATION

60° CONDUCTION

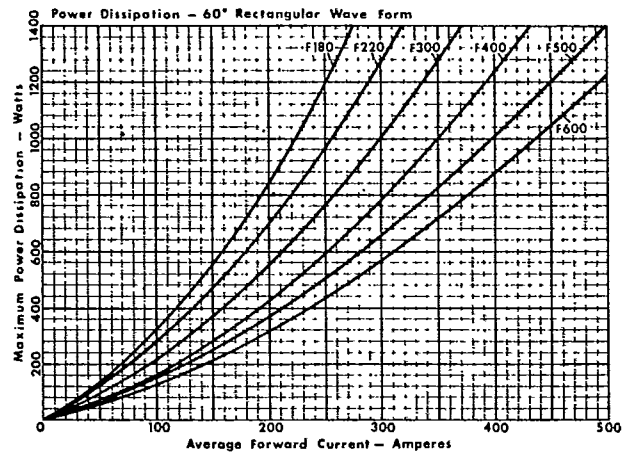
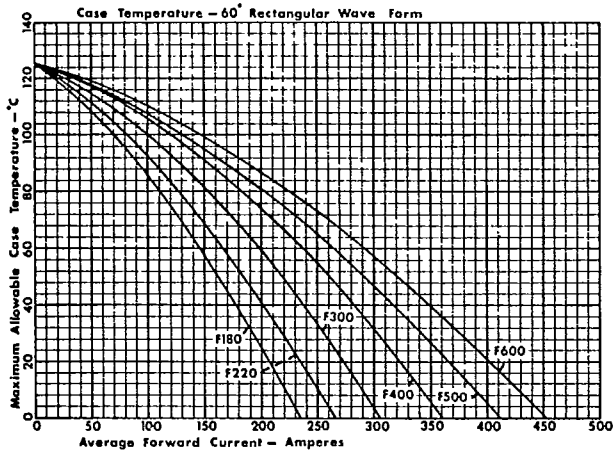

30° CONDUCTION

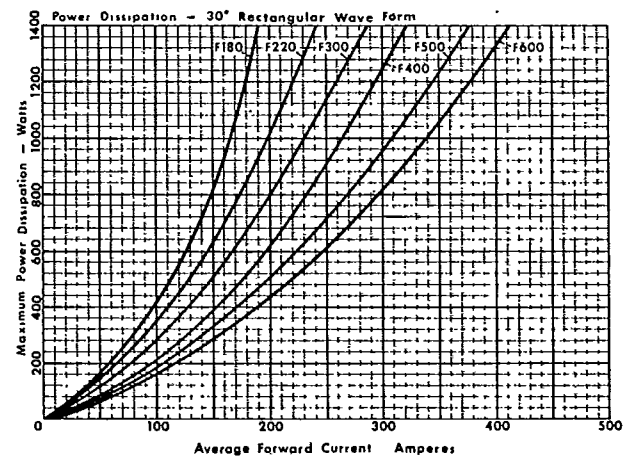
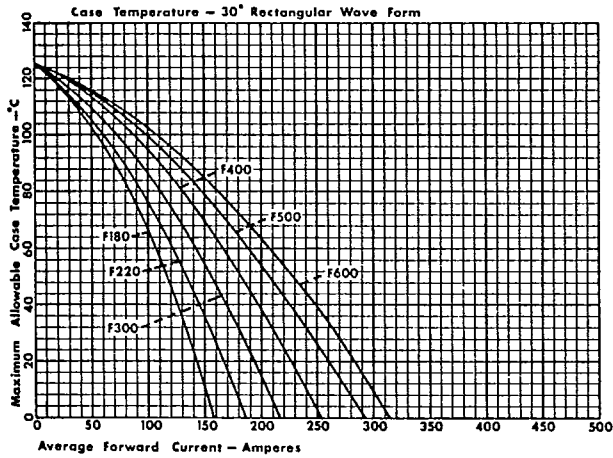

MAXIMUM FORWARD VOLTAGE DROP @125°C

**TRANSIENT THERMAL IMPEDANCE
Junction to Case, Double Side Cooling**

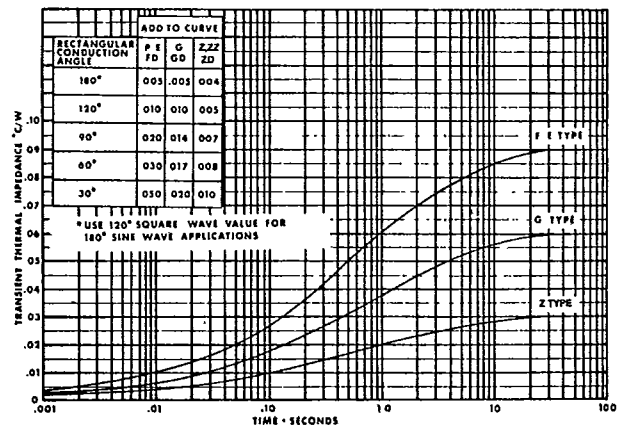
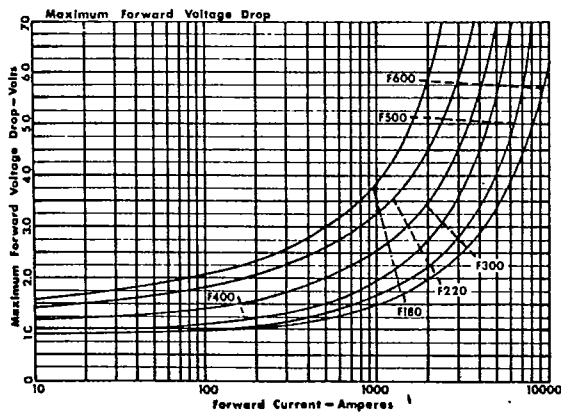

T-01-01
T-25-01

G SERIES MEGA PACKS (33mm.)

**CASE TEMPERATURE
VS
FORWARD CURRENT**

POWER DISSIPATION

**Rectangular Wave Form* — Double Side Cooled
360° or DC CONDUCTION**

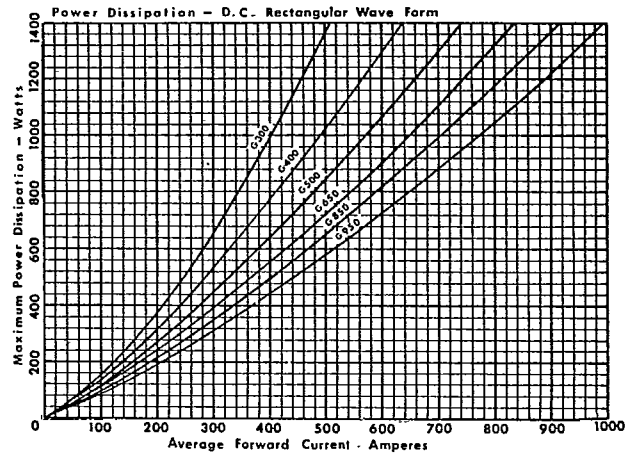
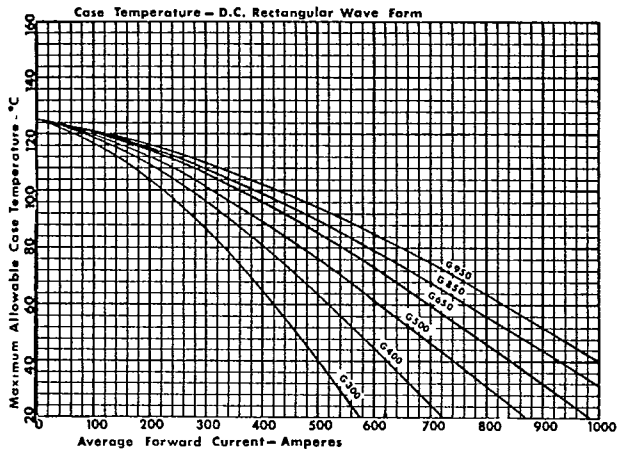

120° CONDUCTION

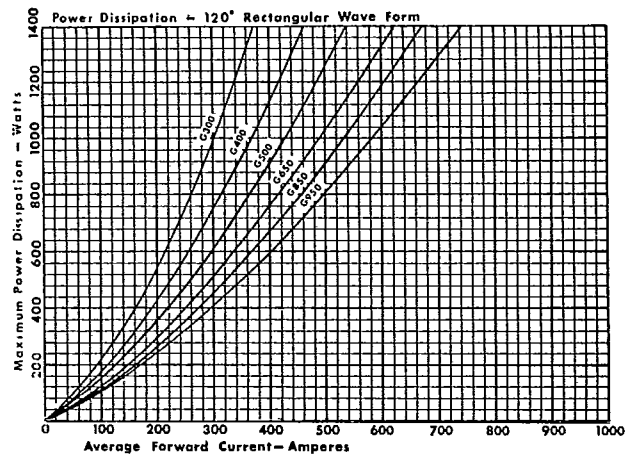
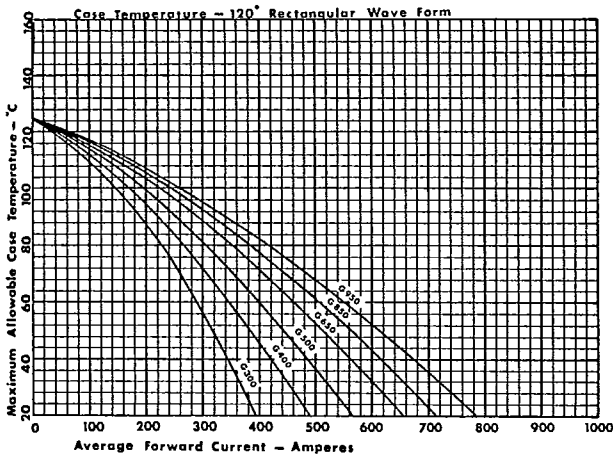

90° CONDUCTION

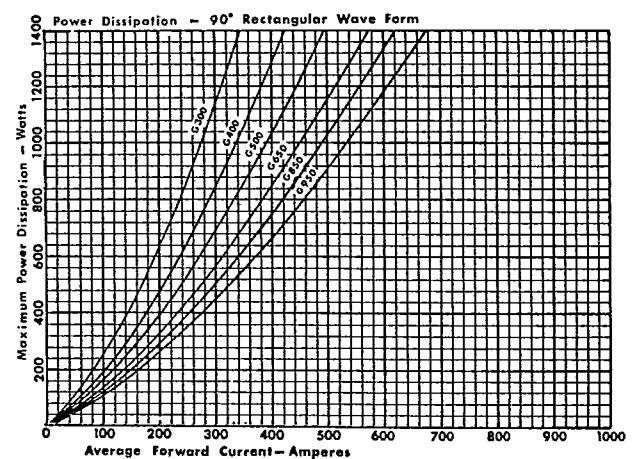
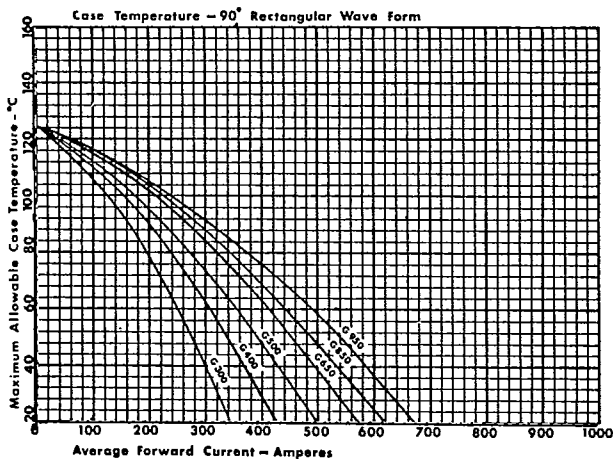

*Use 120° rectangular values for 180° sine wave applications.

T-01-01

T-25-01

G SERIES MEGA PACKS (33mm.)

CASE TEMPERATURE
VS
FORWARD CURRENT

POWER DISSIPATION

60° CONDUCTION

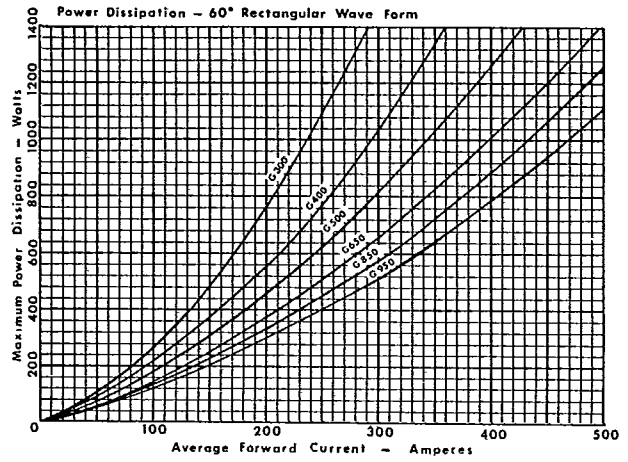
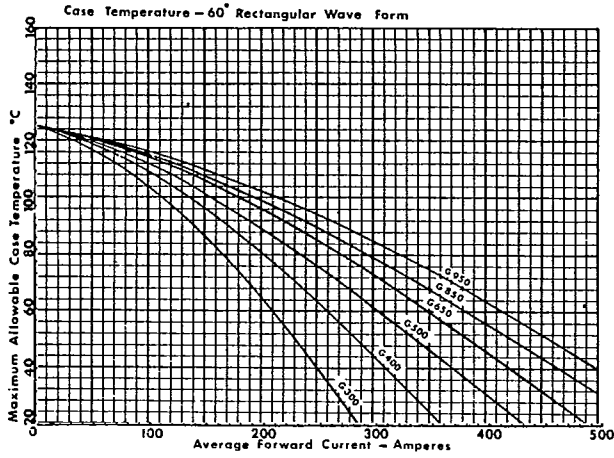

30° CONDUCTION

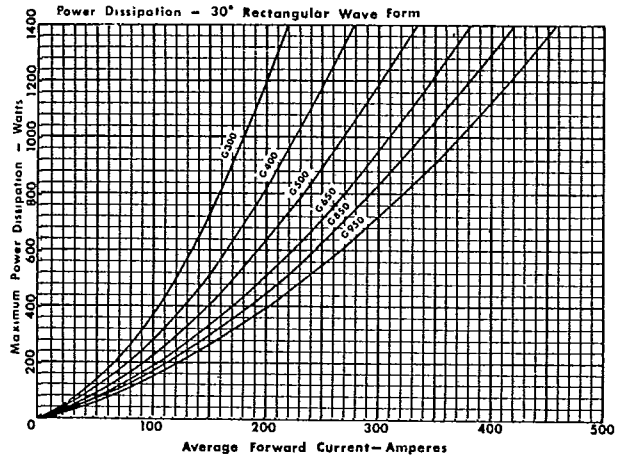
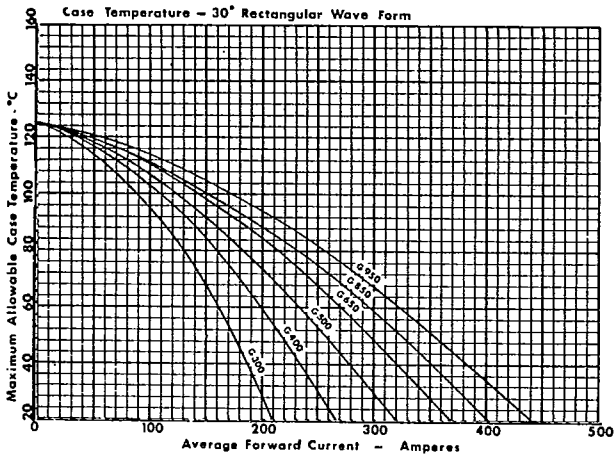

MAXIMUM FORWARD VOLTAGE DROP @ 125°C

TRANSIENT THERMAL IMPEDANCE

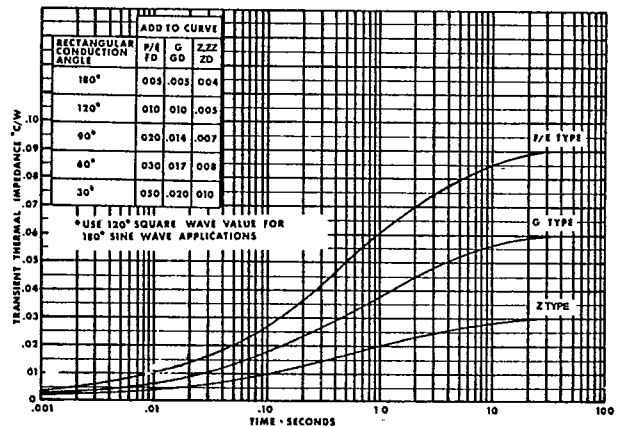
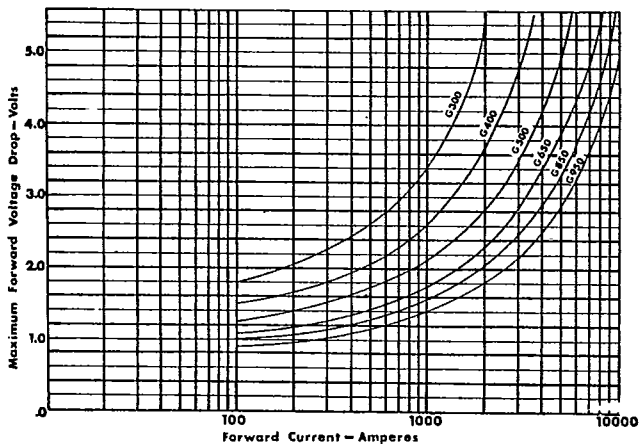

T-01-01
T-25-01

Z SERIES ASTRO PACKS (52mm.)

CASE TEMPERATURE
VS
FORWARD CURRENT

POWER DISSIPATION

Rectangular Wave Form* – Double Side Cooled

360° or DC CONDUCTION

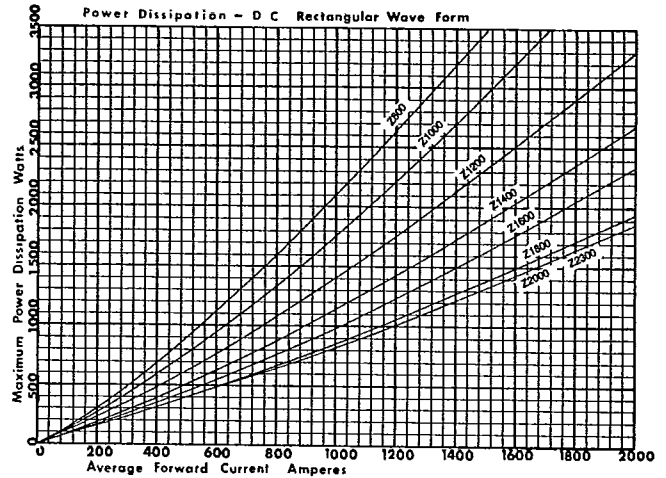
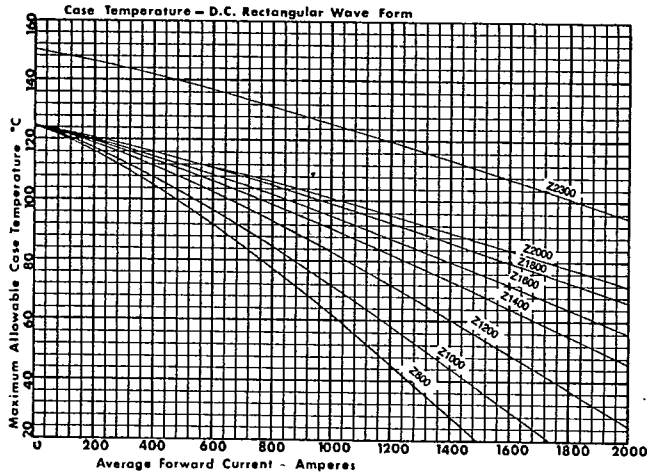

120° CONDUCTION

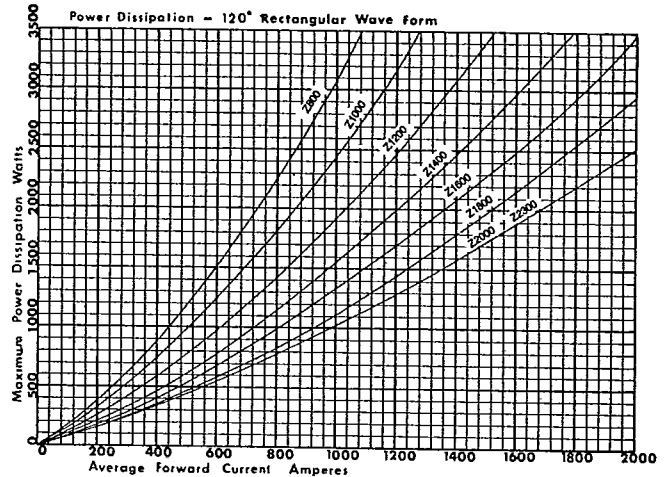
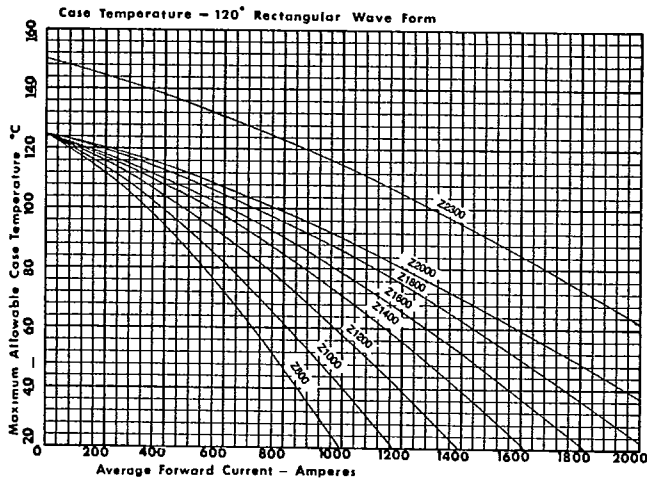

90° CONDUCTION

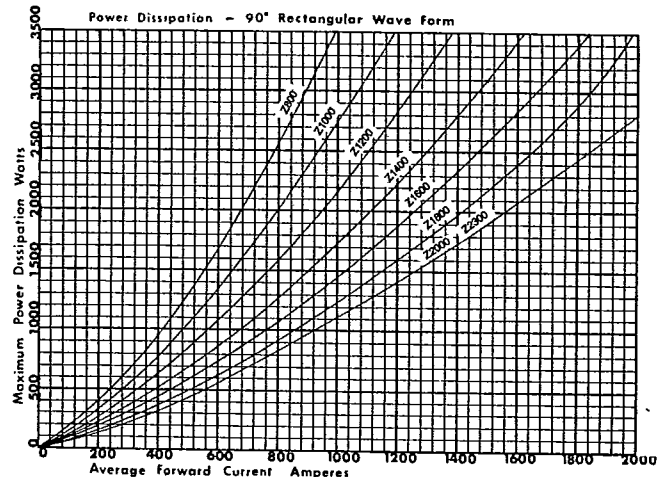
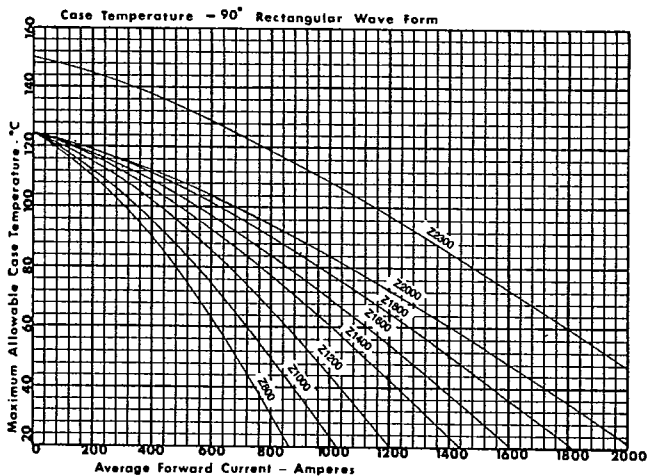

*Use 120° rectangular values for 180° sine wave applications.

T-01-01
T-25-01

Z SERIES ASTRO PACKS (52mm.)

CASE TEMPERATURE
VS
FORWARD CURRENT

POWER DISSIPATION

60° CONDUCTION

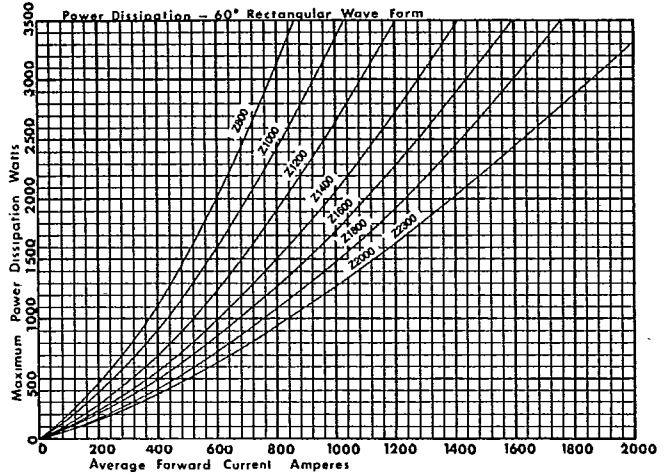
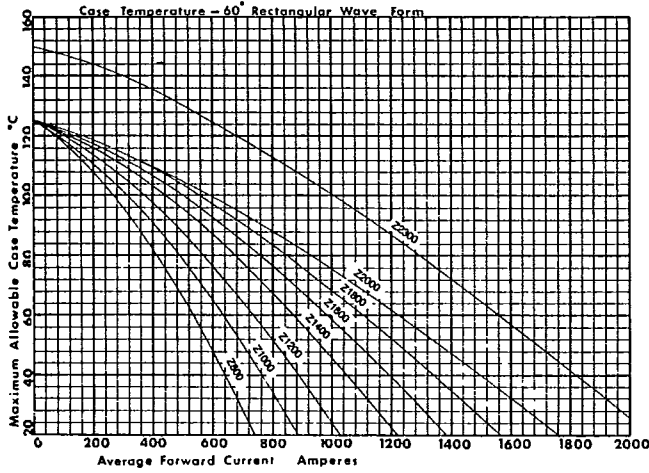

30° CONDUCTION

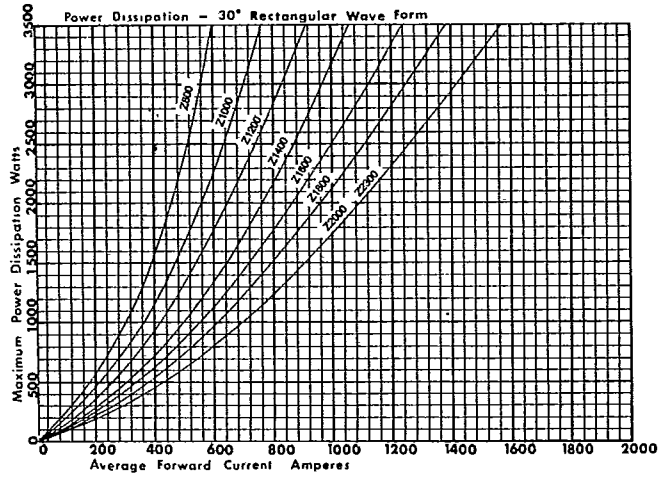
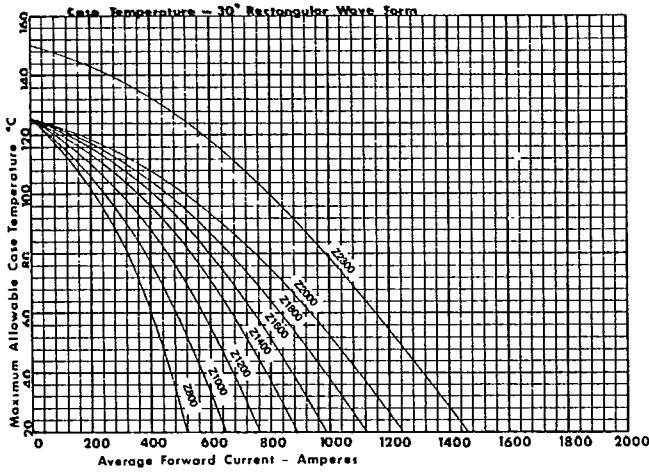

MAXIMUM FORWARD VOLTAGE DROP @ 125°C

TRANSIENT THERMAL IMPEDANCE

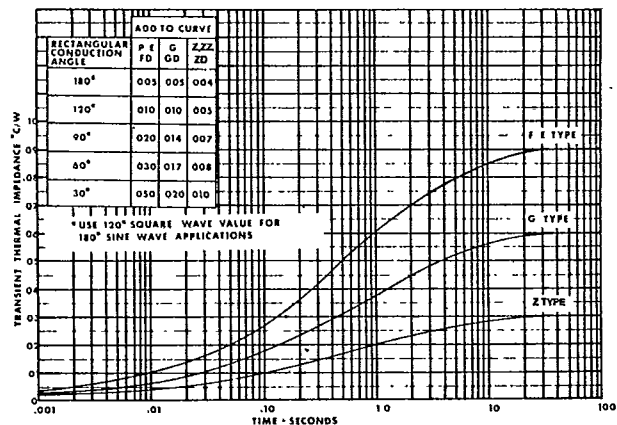
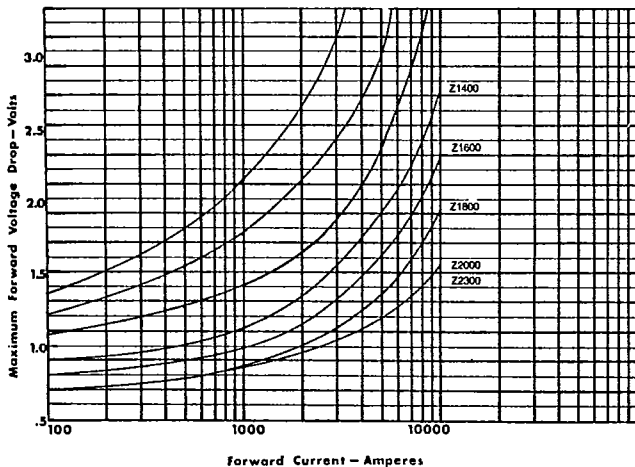

T-01-01
T-25-01

76mm J-PACK, J-D, 102mm K-PACK, K-D

CASE TEMPERATURE
VS
FORWARD CURRENT

POWER DISSIPATION

120° CONDUCTION

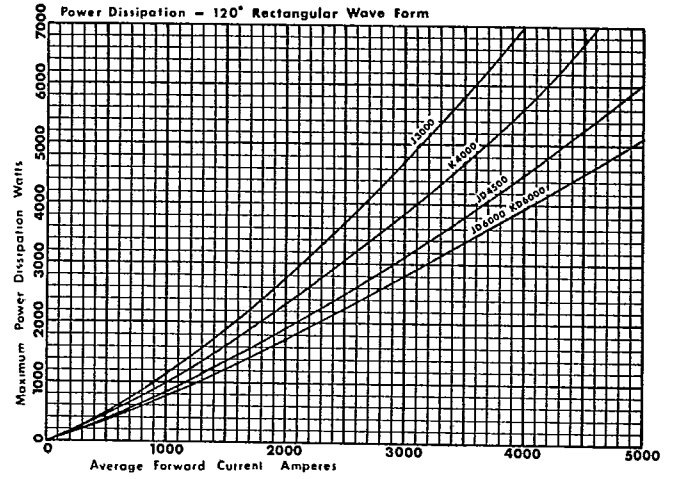
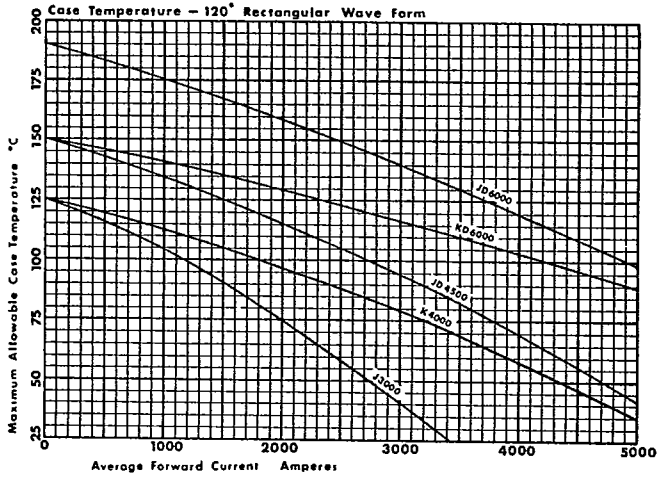

60° CONDUCTION

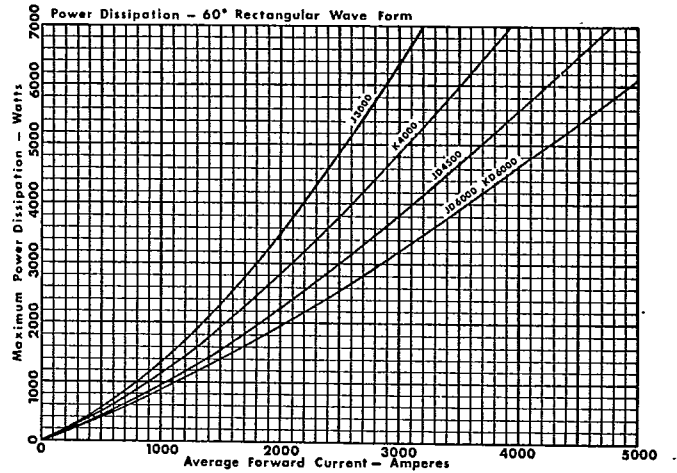
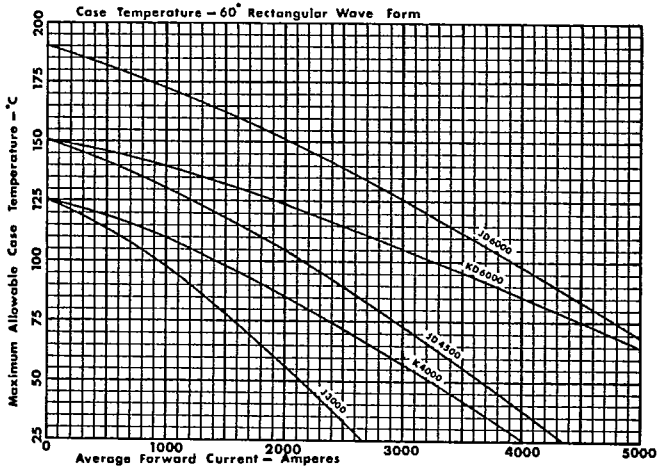

MAXIMUM FORWARD VOLTAGE DROP @ 125°C

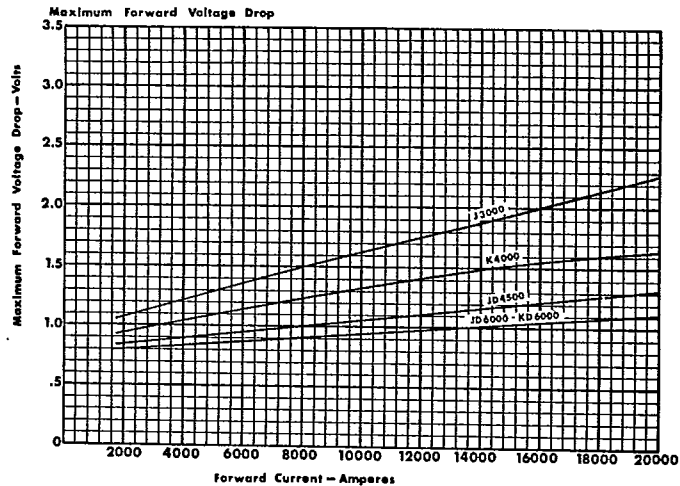

T-01-01
T-25-01

INTERCHANGEABILITY GUIDE

W	PSI	IR	PSI	GE	PSI
T520 - 13	E 180/D 220	175 PA	E 300/D 400	C 350	E 220/D 220
T620 - 13	E 180/D 220	250 PA	E 400/D 400	C 380	E 400/D 400
T620 - 15	E 220/D 220	300 PA	E 500/D 510	A 390	ED 900
T620 - 20	E 300/D 400	350 PL	E 600		
T620 - 28	E 400/D 400			C 430	E 600*
T620 - 30	E 500/D 510			C 450	Z 1600
R620 - 30	ED 600				
R620 - 40	ED 600				
R620 - 50	ED 900				
T720 - 13	F 180	801 PD	GD 1400	C 501	G 950
T720 - 15	F 220	801 PDB	GD 1400	C 507	G 650
T720 - 20	F 300				
T720 - 25	F 400	420 PA 420 PL	G 650 G 850	A 500	GD 1400
T720 - 35	G 650	470 PA	G 850	A 540	GD 1400
T720 - 45	G 850	470 PB 500 PA	G 950 G 850	A 570	GD 1500
T720 - 55	G 950	550 PA	G 950		
		801 PD	GD 1400		
		801 PDB	GD 1400		
T920 - 06	Z 800	700 PA	Z 1000	C 602	Z 800
T920 - 07	Z 1000	700 PK	Z 1000	C 601	Z 1000
T920 - 08	Z 1200	850 PA	Z 1200	C 600	Z 1200
T920 - 09	Z 1200	850 PK	Z 1200	C 701	Z 1600
T920 - 10	Z 1400	1000 PA	Z 1400		
R920 - 11	ZD 1500	1000 PK	Z 1400		
R920 - 16	ZD 2100	1600 PA	Z 2000		
R920 - 20	ZD 2500	2001 PD	ZD 2500		

NOTE Above listing is for guidance only, detailed comparisons should be made from specification sheets.

*E 600 is closest part to C 430; consult factory.

DIODE SERIES FD, GD, ZD (28, 33, 52mm.)

T-01-01
T-25-01

CASE TEMPERATURE
VS
FORWARD CURRENT

POWER DISSIPATION

Rectangular Wave Form* – Double Side Cooled
360° or DC CONDUCTION

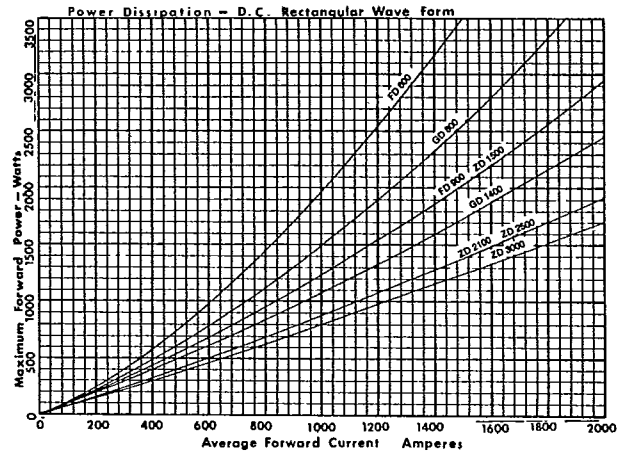
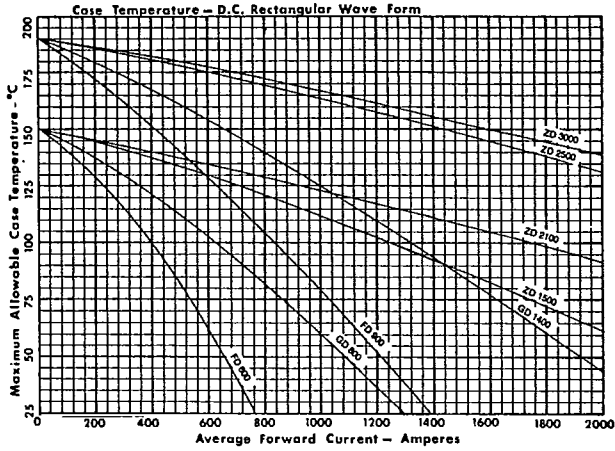

120° CONDUCTION

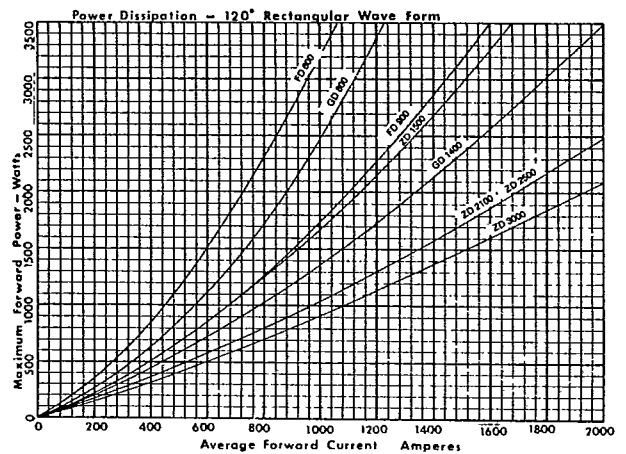
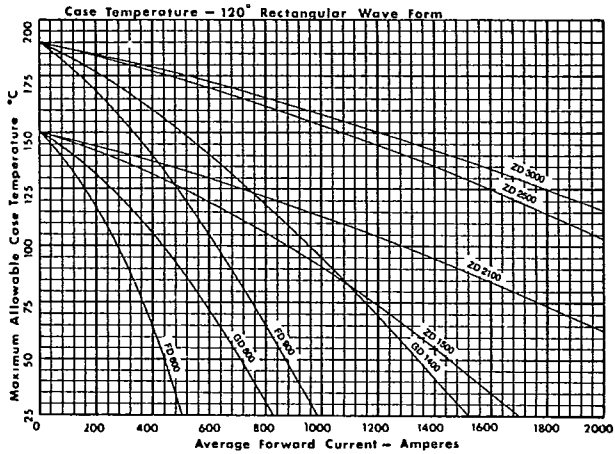

90° CONDUCTION

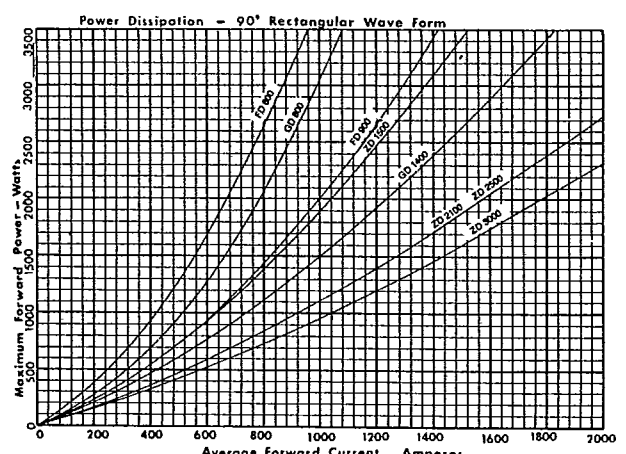
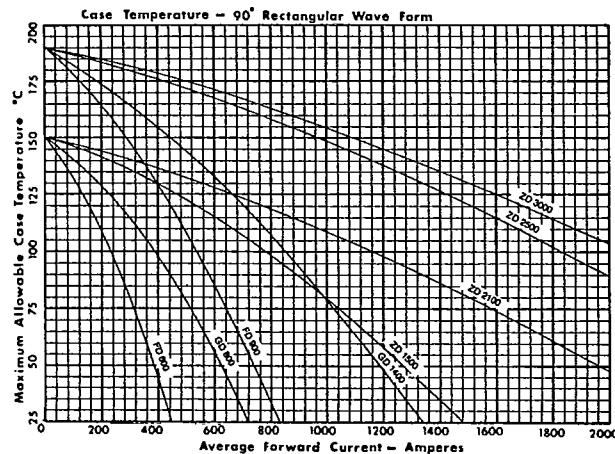

*Use 120° rectangular values for 180° sine wave applications.

T-01-01
T-25-01

P S I POWER PACKAGE ASSEMBLIES

As the first power semiconductor manufacturer to switch completely to pressure mounted devices, P S I was forced to develop hardware and cooling systems before most other suppliers. With the introduction of the 52mm ASTRO-PACK, the 76mm and 102mm units, we had to update this work to mount and cool devices approximately 2.5 times larger than those in general use.

You will see many examples of our results on the next pages, but please remember that all such designs are available to users of P S I semiconductors. P S I has no vested interest in assemblies themselves and will gladly share the details of any standard unit you see on the next page.

(Obviously the custom assemblies we build for many clients remain their exclusive property).

With this thought in mind many customers turn to P S I standard Power Packages for prototype and low volume production, building their own with P S I assistance if ultimate volume warrants. By using common parts they can take advantage of P S I inventories to supplement their own or for emergency service.

Others prefer to let P S I handle the "whole job" in view of the fact that they have enough details to worry about without the following:

What it requires to assemble a Power Package:

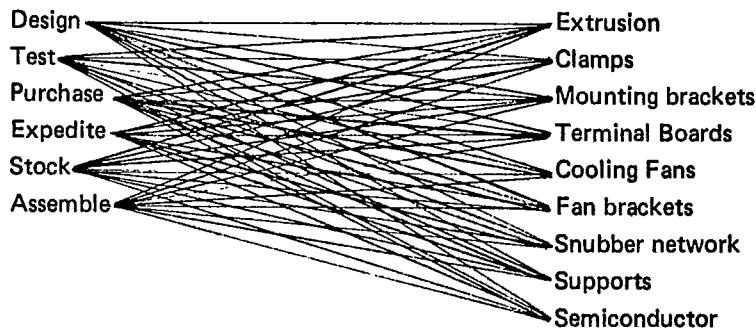

Six steps times nine materials versus the P S I Power Package customer who simply purchases a proven assembly.

How to find the best Power Package for your job.

1. First determine the necessary circuit configuration i.e. A.C. switch, D.C. bridge, star or double wye — single or three phase., e.g. controlling a 100 H.P. A.C. motor requires an A.C. switch.
2. Then, the necessary current to be rectified or controlled, under the most severe possible conditions of temperature, conduction angle, coolant flow, overloads, etc., e.g., continuous line current is 220 amps RMS.
3. What type of cooling is available and desirable. Liquid cooling of course is most effective, then forced air or free convection.

Basic reliability runs in the reverse order, with free convection ideal for relatively light loads and liquid cooling requiring the most attention to many details, e.g. forced air is permissible for our starter example.

4. You can then aim for basic areas from the load current listing on pages 2 and 3. These give close approximations of current available from various P S I devices, using the most popular cooling scheme, heatsinks and flow. e.g. this corresponds to the F-500, on an RL heatsink. We then turn to pages 17A - 17L for more details.

T-01-01
T-25-01

ASSEMBLY ORDERING CODE

A typical basic part number would be as follows:

Code No. -	1	2	3	4	5	6	7	8	
PSI -	6	2	RL	A	F	03	08	SAA	example

Code No.

1. Number of devices in assembly.

2. Number of devices in series with cooling flow.

3. Type of Heatsink:

- UL 6" U-Channel (for F and G Types)
- WM 4.5" Medium (for F and G Types)
- RL 6" Type 42 (for F, G, and Z Types)
- RX 6" Type 42 Copper (for F, G, and Z Types)
- WL 7.5" Large (for F, G, and Z Types)
- AS 6" Astrosink (for F, G, and Z Types)
- XM (for Z and J Types)
- HS Water Cooled (for F, G, and Z Types)
- HL Water Cooled (for J and K Types)

4. Type of Circuit:

- A - AC switch
 - B - Bridge
 - S - Star
 - W - Double Wye
 - P - Parallel
- } cathodes common

5. Device Family:

- F - Power Pack 28mm SCR
- G - Mega Pack 33mm SCR
- H - Astro Pack 52mm SCR
- D - Diode all diodes
- J - J Pack 76mm SCR
- K - K Pack 102mm SCR

6. Type of Device:

Device part number divided by 100
example Z 1000 → 10 G850 → 08

7. Voltage rating of device divided by 100

example 1000V → 10 800V → 08

8. Suffix Letters:

- | | |
|--|--|
| SAA - Mounting tabs, "Fast Access" | SBA - Mounting tabs |
| SAB - Tabs and fan, "Fast Access" | SBB - Tabs and fan |
| SAC - Tabs and 2 fans, "Fast Access" | SBC - Tabs and 2 fans |
| SAD - Phenolic mounting rails | SBD - Phenolic mounting rails |
| SAE - No mounting rails | SBE - No mounting rails |
| SAF - Phenolic mounting rails and 2 fans | SBF - Phenolic mounting rails and 2 fans |

example above

(6 devices)

(2 devices)

(RL Type 42)

(AC Switch)

(F Pack)

(F300)

(800V)

(Mounting Tabs)

example 3 phase 6 SCR Bridge, 2 in series with airflow in a type 42 Heatsink using Z1000-12 with "Fast Access" feature

answer 62RLB Z10-12 SAA

THE ASSEMBLIES ARE SHOWN BELOW WITH OPTIONAL PHENOLIC MOUNTING RAILS:

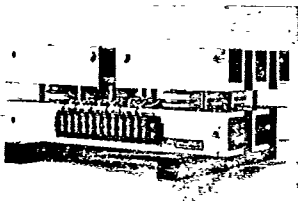

TYPE U

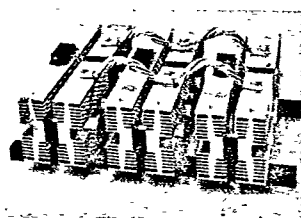

TYPE RL

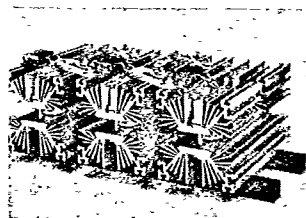

TYPE WM

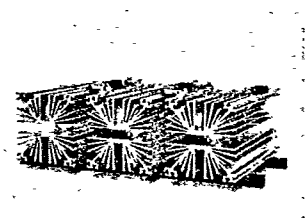

TYPE WL

Note: Types AS, XM come in single heatsinks only. Types HS come in single (11HS), double (22HS) or triple (33HS) only. Types UL, WM, RL, WL, are available in 63 or 33 - assemblies (3 in series with air flow).

T-01-01
T-25-01

HEATSINK THERMAL RESISTANCE (HS. to AMBIENT in °C/W)

AIR COOLED HEATSINKS	NO. IN SERIES with AIR FLOW	0 m/s 0 LFM	2.5 m/s 500 LFM	5.0 m/s 1000 LFM	7.5 m/s 1500 LFM	10.0 m/s 2000 LFM
11 UL	1	1.5	.47	.33	.24	.20
22 UL	2	1.7	.50	.35	.26	.22
33 UL	3	1.9	.53	.37	.28	.24
11 WM	1	.60	.19	.15	.18	.17
22 WM	2	.66	.27	.21	.19	.18
33 WM	3	.70	.32	.23	.20	.19
11 RL	1	.60	.13	.09	.07	.06
22 RL	2	.70	.18	.11	.08	.07
33 RL	3	.80	.23	.15	.12	.10
11 WL	1	.32	.12	.09	.075	.07
22 WL	2	.35	.13	.095	.080	.075
33 WL	3	.40	.14	.10	.085	.08
11 AS	1	.50	.12	.08	.06	.05
11 RX	1	.55	.10	.07	.06	.05
11 XM	1	.24	.06	.04	.035	.03
22 XM	2	.30	.07	.05	.04	.035

WATER COOLED HEATSINKS	NO. IN SERIES with WATER FLOW	.03 l/s .5 GPM	.06 l/s 1.0 GPM	.09 l/s 1.5 GPM	.12 l/s 2.0 GPM
11 HS	1	.03	.02	.015	.01
22 HS	2	.04	.03	.025	.02
33 HS	3	.05	.04	.035	.03
11 HL	1	—	.007	—	—
21 HL	1	—	.007	—	—

T-01-01
T-25-01

3 Ø DC BRIDGE THYRISTOR POWER ASSEMBLY
AIR COOLED UL TYPE HEATSINK
(Two in Series with Air Flow, 120° Conduction)

40°C AIR			DEVICE TYPE	MAX. VOLT. RATING	50°C AIR		
62 ULB –					62 ULB –		
0 m/s 0 LFM	2.5 m/s 500 LFM	5.0 m/s 1000 LFM			0 m/s 0 LFM	2.5 m/s 500 LFM	5.0 m/s 1000 LFM
55	120	174	F 180	3000	40	108	155
70	150	216	F 220	2600	55	132	189
85	210	297	F 300	2000	75	180	261
100	270	354	F 400	1800	90	225	321
120	285	372	F 500	1800	105	240	336
130	300	432	F 600	1000	115	294	381
70	200	260	G 300	3000	55	170	230
85	240	320	G 400	2600	75	210	280
100	290	260	G 500	2000	90	260	330
120	320	410	G 650	1800	105	290	370
140	350	440	G 850	1800	120	310	400
160	380	480	G 950	1600	140	340	430

3 Ø DC BRIDGE THYRISTOR POWER ASSEMBLY
AIR COOLED WM TYPE HEATSINK
(Two in Series with Air Flow, 120° Conduction)

40°C AIR			DEVICE TYPE	MAX. VOLT. RATING	50° AIR		
62 WMB –					62 WMB –		
0 m/s 0 LFM	2.5 m/s 500 LFM	5.0 m/s 1000 LFM			0 m/s 0 LFM	2.5 m/s 500 LFM	5.0 m/s 1000 LFM
150	210	252	F 180	3000	130	180	219
180	255	300	F 220	2600	160	225	270
215	330	390	F 300	2000	195	300	360
265	390	480	F 400	1800	245	360	435
290	420	510	F 500	1800	270	390	450
340	495	585	F 600	1000	310	450	525
170	310	360	G 300	3000	150	280	330
230	420	510	G 500	2000	210	380	460
270	480	580	G 650	1800	420	430	520
300	520	620	G 850	1800	270	430	560
330	560	680	G 950	1600	300	510	620

T-01-01
T-25-01

3 Ø DC BRIDGE THYRISTOR POWER ASSEMBLY
AIR COOLED RL TYPE HEATSINK
(Two in Series with Air Flow, 120° Conduction)

40° C AIR				DEVICE TYPE	MAX. VOLT. RATING	50° C AIR			
62 RLB -						62 RLB -			
0 m/s 0 LFM	2.5 m/s 500 LFM	5.0 m/s 1000 LFM	7.5 m/s 1500 LFM			0 m/s 0 LFM	2.5 m/s 500 LFM	5.0 m/s 1000 LFM	7.5 m/s 1500 LFM
120	270	340	380	F 180	3000	100	240	310	340
150	330	400	450	F 220	2600	130	290	360	400
190	420	520	580	F 300	2000	170	380	470	520
250	510	630	700	F 400	1800	230	460	570	640
290	540	670	750	F 500	1800	260	480	600	670
320	620	750	840	F 600	1000	290	550	680	760
170	380	480	550	G 300	3000	150	350	440	500
200	460	590	670	G 400	2600	180	420	530	610
230	540	680	770	G 500	2000	210	490	620	700
270	620	770	890	G 650	1800	240	560	700	800
300	660	840	950	G 850	1800	270	600	760	860
330	720	920	1040	G 950	1600	300	650	830	950
200	610	820	980	Z 800	3000	180	550	740	890
270	690	940	1120	Z 1000	2600	250	620	850	1010
330	830	1130	1350	Z 1200	2000	300	750	1020	1220
360	990	1350	1600	Z 1400	1800	330	890	1220	1450
390	1110	1510	1800	Z 1600	1400	360	1000	1360	1630
440	1270	1720	2050	Z 1800	600	390	1140	1560	1850
480	1310	1810	2170	Z 2000	600	420	1180	1630	1960
600	1640	2250	2680	Z 2300	400	510	1520	2080	2480

T-01-01
T-25-01

3 Ø DC BRIDGE THYRISTOR POWER ASSEMBLY
AIR COOLED WL TYPE HEATSINK
(Two in Series with Air Flow, 120° Conduction)

40° C AIR				DEVICE TYPE	MAX. VOLT. RATING	50° C AIR			
62 WLB -						62 WLB -			
0 m/s 0 LFM	2.5 m/s 500 LFM	5.0 m/s 1000 LFM	7.5 m/s 1500 LFM			0 m/s 0 LFM	2.5 m/s 500 LFM	5.0 m/s 1000 LFM	7.5 m/s 1500 LFM
170	320	360	380	F 180	3000	150	280	320	340
220	380	430	450	F 220	2600	190	340	380	400
300	480	540	580	F 300	2000	260	440	490	520
350	590	660	700	F 400	1800	320	530	600	640
370	630	700	750	F 500	1800	340	560	640	670
420	710	800	840	F 600	1600	380	640	720	760
260	450	510	550	G 300	3000	230	400	470	500
320	550	630	670	G 400	2600	280	490	570	610
360	640	720	770	G 500	2000	330	580	660	700
410	720	830	890	G 650	1800	370	650	750	800
440	780	900	950	G 850	1800	400	700	810	860
480	850	950	1040	G 950	1600	430	770	870	950
380	740	900	980	Z 800	3000	340	670	800	890
430	860	1020	1120	Z 1000	2600	380	770	930	1010
510	1030	1230	1350	Z 1200	2000	460	930	1110	1220
610	1220	1460	1600	Z 1400	1800	540	1100	1340	1450
680	1370	1630	1800	Z 1600	1400	610	1230	1480	1130
780	1560	1880	2050	Z 1800	600	700	1410	1700	1850
790	1640	1980	2170	Z 2000	600	710	1470	1800	1960
1000	2040	2460	2680	Z 2300	400	920	1880	2260	2480

**3 Ø DC BRIDGE THYRISTOR POWER ASSEMBLY
AIR COOLED AS TYPE HEATSINK
(One in Series with Air Flow, 120° Conduction)**

T-01-01
T-25-01

40° C AIR			DEVICE TYPE	MAX. VOLT. RATING	50° C AIR		
62 ASB -					62 ASB -		
5.0 m/s 1000 LFM	7.5 m/s 1500 LFM	10.0 m/s 2000 LFM			5.0 m/s 1000 LFM	7.5 m/s 1500 LFM	10.0 m/s 2000 LFM
980	1120	1210	Z 800	3000	890	1010	1100
1120	1290	1390	Z 1000	2600	1010	1170	1260
1350	1550	1680	Z 1200	2000	1220	1400	1520
1600	1840	1990	Z 1400	1800	1450	1670	1800
1800	2070	2230	Z 1600	1400	1630	1870	2020
1050	2340	2530	Z 1800	600	1850	2130	2300
2170	2500	2710	Z 2000	600	1960	2260	2450
2680	3070	2210	Z 2300	400	2480	2840	3080

**3 Ø DC BRIDGE THYRISTOR POWER ASSEMBLY
AIR COOLED XM TYPE HEATSINK
(One in Series with Air Flow, 120° Conduction)**

40° C AIR			DEVICE TYPE	MAX. VOLT. RATING	50° C AIR		
61 XMB -					61 XMB -		
5.0 m/s 1000 LFM	7.5 m/s 1500 LFM	10.0 m/s 2000 LFM			5.0 m/s 1000 LFM	7.5 m/s 1500 LFM	10.0 m/s 2000 LFM
1320	1380	1450	Z 800	3000	1200	1260	1320
1520	1600	1680	Z 1000	2600	1380	1450	1520
1830	1920	2020	Z 1200	2000	1660	1740	1830
2170	2280	2390	Z 1400	1800	1970	2070	2170
2440	2560	2680	Z 1600	1400	2210	2320	2440
2760	2890	3030	Z 1800	600	2510	2630	2760
1960	3110	3260	Z 2000	600	2680	2820	2960
3600	3770	3950	Z 2300	400	3350	3510	3680

T-01-01
T-25-01

**1 Ø and 3 Ø AC SWITCH THYRISTOR POWER ASSEMBLY
AIR COOLED UL TYPE HEATSINK
(Two in Series with Air Flow, 180° Conduction)**

40° C AIR			DEVICE TYPE	MAX. VOLT. RATING	50° C AIR		
22 ULA – or 62 ULA –					22 ULA – or 62 ULA –		
0 m/s 0 LFM	2.5 m/s 500 LFM	5.0 m/s 1000 LFM			0 m/s 0 LFM	2.5 m/s 500 LFM	5.0 m/s 1000 LFM
40	90	130	F 180	3000	30	80	113
50	110	160	F 220	2600	40	98	140
65	160	220	F 300	2000	55	133	193
75	200	260	F 400	1800	70	167	238
80	210	280	F 500	1800	75	178	249
85	220	310	F 600	1000	80	218	282
50	150	190	G 300	3000	40	120	170
60	180	240	G 400	2600	55	150	210
75	210	270	G 500	2000	65	190	240
85	240	300	G 650	1800	75	210	270
100	260	330	G 800	1800	90	230	290
120	280	360	G 950	1600	100	250	320

**1 Ø and 3 Ø AC SWITCH THYRISTOR POWER ASSEMBLY
AIR COOLED WM TYPE HEATSINK
(Two in Series with Air Flow, 180° Conduction)**

40° C AIR			DEVICE TYPE	MAX. VOLT. RATING	50° C AIR		
22 WMA – or 62 WMA –					22 WMA – or 62 WMA –		
0 m/s 0 LFM	2.5 m/s 500 LFM	5.0 m/s 1000 LFM			0 m/s 0 LFM	2.5 m/s 500 LFM	5.0 m/s 1000 LFM
110	155	185	F 180	3000	95	130	160
130	199	220	F 220	2600	120	165	200
160	245	290	F 300	2000	145	220	265
195	290	355	F 400	1800	180	265	320
215	310	380	F 500	1800	200	290	330
250	365	430	F 600	1000	230	330	390
125	230	270	G 300	3000	110	210	240
150	270	320	G 400	2600	130	240	290
170	310	380	G 500	2000	155	280	340
200	350	430	G 650	1800	175	320	380
220	380	460	G 850	1800	200	350	410
245	410	500	G 950	1600	220	380	460

1 Ø and 3 Ø AC SWITCH THYRISTOR POWER ASSEMBLY
 AIR COOLED RL TYPE HEATSINK
 (Two in Series with Air Flow, 180° Conduction)

T-01-01
 T-25-01

40° C AIR				DEVICE TYPE	MAX. VOLT. RATING	50° C AIR			
22 RLA – or 62 RLA –						22 RLA – or 62 RLA –			
0 m/s 0 LFM	2.5 m/s 500 LFM	5.0 m/s 1000 LFM	7.5 m/s 1500 LFM			0 m/s 0 LFM	2.5 m/s 500 LFM	5.0 m/s 1000 LFM	7.5 m/s 1500 LFM
85	200	250	280	F 180	3000	75	180	230	250
110	240	300	330	F 220	2600	95	210	270	300
140	310	380	430	F 300	2000	125	280	350	380
185	380	470	520	F 400	1800	170	340	420	470
215	400	500	560	F 500	1800	190	360	450	500
235	460	560	620	F 600	1000	215	410	500	560
125	280	350	410	G 300	3000	110	260	320	370
145	340	430	490	G 400	2600	130	310	390	450
170	400	500	570	G 500	2000	155	360	460	520
200	460	570	660	G 650	1800	175	410	520	590
220	490	620	700	G 850	1800	200	440	560	630
245	530	680	770	G 950	1600	220	480	610	700
145	450	610	730	Z 800	3000	130	410	550	660
200	510	700	830	Z 1000	2600	185	460	630	750
245	610	840	1000	Z 1200	2000	220	560	750	900
265	730	1000	1180	Z 1400	1800	240	660	900	1070
290	820	1120	1330	Z 1600	1400	260	740	1000	1210
320	940	1270	1520	Z 1800	600	290	840	1150	1370
350	970	1340	1610	Z 2000	600	310	870	1200	1450
440	1210	1670	1980	Z 2300	400	380	1120	1540	1840

1 Ø and 3 Ø AC SWITCH THYRISTOR POWER ASSEMBLY
 AIR COOLED WL TYPE HEATSINK
 (Two in Series with Air Flow, 180° Conduction)

T-01-01
 T-25-01

40° C AIR				DEVICE TYPE	MAX. VOLT. RATING	50° C AIR			
22 WLA - or 62 WLA -						22 WLA - or 62 WLA -			
0 m/s 0 LFM	2.5 m/s 500 LFM	5.0 m/s 1000 LFM	7.5 m/s 1500 LFM			0 m/s 0 LFM	2.5 m/s 500 LFM	5.0 m/s 1000 LFM	7.5 m/s 1500 LFM
130	240	270	280	F 180	3000	110	210	240	250
160	280	320	330	F 220	2600	140	250	280	300
220	360	400	430	F 300	2000	190	330	360	380
260	440	490	520	F 400	1800	240	390	440	470
270	470	520	560	F 500	1800	250	410	470	500
310	530	590	620	F 600	1000	280	470	530	560
190	330	380	410	G 300	3000	170	290	350	370
230	410	460	490	G 400	2600	210	360	420	450
260	470	530	570	G 500	2000	240	430	490	520
300	530	610	660	G 650	1800	270	480	550	590
320	580	660	700	G 850	1800	290	520	600	630
350	630	700	770	G 950	1600	320	570	640	700
280	550	670	730	Z 800	3000	250	500	590	660
320	640	750	830	Z 1000	2600	280	570	690	750
380	760	910	1000	Z 1200	2000	340	690	820	900
450	900	1080	1180	Z 1400	1800	400	810	990	1070
500	1010	1210	1330	Z 1600	1400	450	910	1100	1200
580	1150	1390	1510	Z 1800	600	520	1040	1260	1370
585	1210	1470	1610	Z 2000	600	530	1090	1330	1450
740	1510	1820	1980	Z 2300	400	680	1390	1670	1840

T-01-01
T-25-01

1 Ø and 3 Ø AC SWITCH THYRISTOR POWER ASSEMBLY
AIR COOLED ASA TYPE HEATSINK
(One in Series with Air Flow, 180° Conduction)

40° C AIR			DEVICE TYPE	MAX. VOLT. RATING	50° C AIR		
22 ASA – or 62 ASA –					22 ASA – or 62 ASA –		
5.0 m/s 1000 LFM	7.5 m/s 1500 LFM	10.0 m/s 2000 LFM			5.0 m/s 1000 LFM	7.5 m/s 1500 LFM	10.0 m/s 2000 LFM
720	830	890	Z 800	3000	660	750	810
830	950	1030	Z 1000	2600	750	860	930
1000	1150	1240	Z 1200	2000	900	1030	1120
1180	1360	1470	Z 1400	1800	1070	1230	1330
1330	1530	1650	Z 1600	1400	1200	1380	1490
1520	1730	1870	Z 1800	600	1370	1570	1700
1600	1850	2000	Z 2000	600	1450	1670	1810
1980	2270	2450	Z 2300	400	1830	2100	2280

1 Ø and 3 Ø AC SWITCH THYRISTOR POWER ASSEMBLY
AIR COOLED XM TYPE HEATSINK
(One in Series with Air Flow 180° Conduction)

40° C AIR			DEVICE TYPE	MAX. VOLT. RATING	50° C AIR		
22 XMA – or 62 XMA –					22 XMA – or 62 XMA –		
5.0 m/s 1000 LFM	7.5 m/s 1500 LFM	10.0 m/s 2000 LFM			5.0 m/s 1000 LFM	7.5 m/s 1500 LFM	10.0 m/s 2000 LFM
970	1020	1070	Z 800	3000	890	930	970
1120	1180	1240	Z 1000	2600	1020	1070	1120
1350	1420	1490	Z 1200	2000	1230	1290	1350
1600	1690	1770	Z 1400	1800	1460	1530	1600
1800	1890	1980	Z 1600	1400	1630	1710	1800
2040	2140	2240	Z 1800	600	1860	1940	2040
2190	2300	2410	Z 2000	600	1980	2080	2190
2660	2790	2920	Z 2300	400	2480	2600	2720

T-01-01
T-25-01

**3 Ø DC BRIDGE DIODE POWER ASSEMBLY
AIR COOLED UL TYPE HEATSINK
(Two in Series with Air Flow, 120° Conduction)**

40° C AIR			DEVICE TYPE	MAX. VOLT. RATING	50° C AIR		
62 ULB -					62 ULB -		
0 m/s 0 LFM	2.5 m/s 500 LFM	5.0 m/s 1000 LFM			0 m/s 0 LFM	2.5 m/s 500 LFM	5.0 m/s 1000 LFM
100	360	450	FD 600	3000	90	340	420
190	610	780	FD 900	2000	180	580	730
135	450	580	GD 800	3000	120	410	530
250	730	950	GD 1400	2000	230	680	890

**3 Ø DC BRIDGE DIODE POWER ASSEMBLY
AIR COOLED WM TYPE HEATSINK
(Two in Series with Air Flow, 120° Conduction)**

40° C AIR			DEVICE TYPE	MAX. VOLT. RATING	50° C AIR		
62 WMB -					62 WMB -		
0 m/s 0 LFM	2.5 m/s 500 LFM	5.0 m/s 1000 LFM			0 m/s 0 LFM	2.5 m/s 500 LFM	5.0 m/s 1000 LFM
250	510	610	FD 600	3000	230	480	560
490	910	1080	FD 900	2000	460	850	1020
330	660	810	GD 800	3000	300	630	750
590	1120	1360	GD 1400	2000	550	1050	1280

**3 Ø DC BRIDGE DIODE POWER ASSEMBLY
AIR COOLED RL TYPE HEATSINK
(Two in Series with Air Flow, 120° Conduction)**

*T-01-01
T-25-01*

40° C AIR				DEVICE TYPE	MAX. VOLT. RATING	50° C AIR			
62 RLB-						62 RLB-			
0 m/s 0 LFM	2.5 m/s 500 LFM	5.0 m/s 1000 LFM	7.5 m/s 1500 LFM			0 m/s 0 LFM	2.5 m/s 500 LFM	5.0 m/s 1000 LFM	7.5 m/s 1500 LFM
240	630	760	840	FD 600	3000	220	590	780	780
470	1140	1400	1560	FD 900	2000	430	1070	1330	1480
320	860	1080	1220	GD 800	3000	290	790	1000	1140
560	1450	1860	2130	GD 1400	2000	530	1360	1760	2010
380	1130	1540	1830	ZD 1500	3000	340	1040	1430	1700
520	1580	2180	2610	ZD 2100	2000	480	1450	2010	2410
700	2070	2830	3370	ZD 2500	1200	660	1950	2670	3190
770	2290	3150	3770	ZD 3000	600	720	2160	2970	3560

**3 Ø DC BRIDGE DIODE POWER ASSEMBLY
AIR COOLED WL TYPE HEATSINK
(Two in Series with Air Flow, 120° Conduction)**

40° C AIR				DEVICE TYPE	MAX. VOLT. RATING	50° C AIR			
62 WLB -						62 WLB -			
0 m/s 0 LFM	2.5 m/s 500 LFM	5.0 m/s 1000 LFM	7.5 m/s 1500 LFM			0 m/s 0 LFM	2.5 m/s 500 LFM	5.0 m/s 1000 LFM	7.5 m/s 1500 LFM
450	720	800	840	FD 600	3000	420	670	750	780
780	1320	1480	1560	FD 900	2000	730	1240	1400	1480
580	1000	1140	1220	GD 800	3000	530	930	1060	1140
950	1720	1980	2130	GD 1400	2000	890	1620	1870	2010
700	1400	1670	1830	ZD 1500	3000	640	1290	1540	1700
950	1960	2380	2610	ZD 2100	2000	870	1810	2190	2410
1260	2550	3090	3370	ZD 2500	1200	1190	2410	2760	3190
1390	2840	3430	3770	ZD 3000	600	1310	2680	3240	3560

T-01-01
T-25-01

**3 Ø DC BRIDGE DIODE POWER ASSEMBLY
AIR COOLED AS TYPE HEATSINK
(One in Series with Air Flow, 120° Conduction)**

40° C AIR			DEVICE TYPE	MAX. VOLT. RATING	50° C AIR		
62 ASB –					62 ASB –		
5.0 m/s 1000 LFM	7.5 m/s 1500 LFM	10.0 m/s 2000 LFM			5.0 m/s 1000 LFM	7.5 m/s 1500 LFM	10.0 m/s 2000 LFM
1830	2100	2270	ZD 1500	3000	1700	1950	2110
2610	3020	3280	ZD 2100	2000	2410	2790	3030
3370	3890	4210	ZD 2500	1200	3190	3680	3980
3770	4356	4720	ZD 3000	600	3560	4110	4470

**3 Ø DC BRIDGE DIODE POWER ASSEMBLY
AIR COOLED XM TYPE HEATSINK
(One in Series with Air Flow, 120° Conduction)**

40° C AIR			DEVICE TYPE	MAX. VOLT. RATING	50° C AIR		
62 XMB –					62 XMB –		
5.0 m/s 1000 LFM	7.5 m/s 1500 LFM	10.0 m/s 2000 LFM			5.0 m/s 1000 LFM	7.5 m/s 1500 LFM	10.0 m/s 2000 LFM
2470	2590	2710	ZD 1500	3000	2300	2410	2520
3590	3780	3970	ZD 2100	2000	3320	3500	3680
4590	4950	5070	ZD 2000	1200	4350	4570	4800
5160	5430	5700	ZD 3000	600	4890	5140	5400

**6 Ø STAR DIODE POWER ASSEMBLY
AIR COOLED AS TYPE HEATSINK
(One in Series with Air Flow, 60° Conduction)**

40° C AIR			DEVICE TYPE	MAX. VOLT. RATING	50° C AIR		
62 ASS –					62 ASS –		
5.0 m/s 1000 LFM	7.5 m/s 1500 LFM	10.0 m/s 2000 LFM			5.0 m/s 1000 LFM	7.5 m/s 1500 LFM	10.0 m/s 2000 LFM
3050	3440	3690	ZD 1500	3000	2840	3210	3450
4490	5130	5540	ZD 2100	2000	4170	4770	5140
5720	6510	6990	ZD 2000	1200	5430	6180	6650
6450	7360	7920	ZD 3000	600	6120	6980	7520

**6 Ø STAR DIODE POWER ASSEMBLY
AIR COOLED XM TYPE HEATSINK
(One in Series with Air Flow, 60° Conduction)**

40° C AIR			DEVICE TYPE	MAX. VOLT. RATING	50° C AIR		
62 XMS –					62 XMS –		
5.0 m/s 1000 LFM	7.5 m/s 1500 LFM	10.0 m/s 2000 LFM			5.0 m/s 1000 LFM	7.5 m/s 1500 LFM	10.0 m/s 2000 LFM
3980	4150	4330	ZD 1500	3000	3720	3880	4050
6010	6290	6580	ZD 2100	2000	5580	5850	6120
7580	7930	8280	ZD 2500	1200	7200	7530	7870
8600	9000	9400	ZD 3000	600	8160	8540	8930

**6 Ø STAR DIODE POWER ASSEMBLY
AIR COOLED RL TYPE HEATSINK
(Two in Series with Air Flow, 60° Conduction)**

*T-01-01
T-25-01*

40° C AIR				DEVICE TYPE	MAX. VOLT. RATING	50° C AIR			
62 RLS -						62 RLS -			
0 m/s 0 LFM	2.5 m/s 500 LFM	5.0 m/s 1000 LFM	7.5 m/s 1500 LFM			0 m/s 0 LFM	2.5 m/s 500 LFM	5.0 m/s 1000 LFM	7.5 m/s 1500 LFM
	990	1190	1290	FD 600	3000		920	1100	1220
	1884	2250	2460	FD 900	2000		1790	2130	2340
	1400	1740	1930	GD 800	3000		1310	1620	1820
	2500	3140	3540	GD 1400	2000		2370	2980	3350
	1970	2600	3050	ZD 1500	3000		1830	2430	2840
	2820	3800	4490	ZD 2100	2000		2600	3520	4170
	3630	4860	5720	ZD 2500	1200		3440	4610	5430
	4070	5470	6450	ZD 3000	600		3840	5180	6120

**6 Ø STAR DIODE POWER ASSEMBLY
AIR COOLED WL TYPE HEATSINK
(Two in Series with Air Flow, 60° Conduction)**

40° C AIR				DEVICE TYPE	MAX. VOLT. RATING	50° C AIR			
62 WLS -						62 WLS -			
0 m/s 0 LFM	2.5 m/s 500 LFM	5.0 m/s 1000 LFM	7.5 m/s 1500 LFM			0 m/s 0 LFM	2.5 m/s 500 LFM	5.0 m/s 1000 LFM	7.5 m/s 1500 LFM
730	1130	1240	1290	FD 600	3000	680	1040	1160	1220
1350	2120	2350	2460	FD 900	2000	1280	2020	2230	2340
980	1620	1830	1930	GD 800	3000	900	1510	1710	1820
1690	2930	3320	3540	GD 1400	2000	1590	2770	3150	3350
1250	2390	2810	3050	ZD 1500	3000	1180	2210	2620	2840
1760	3450	4110	4490	ZD 2100	2000	1610	3200	3810	4170
2290	4430	5250	5720	ZD 2500	1200	2160	4190	4970	5430
2540	4970	5910	6450	ZD 3000	600	2400	4710	5610	6120

AIR COOLED ASSEMBLY OUTLINES

TYPE 22 ULA-

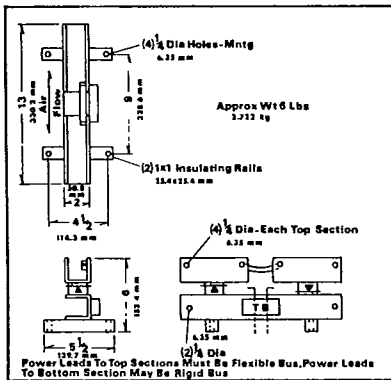

TYPE 62 ULB-

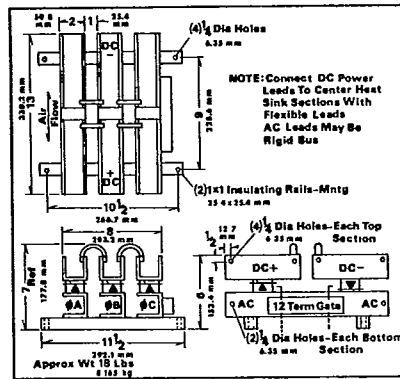

TYPE 62 ULA-

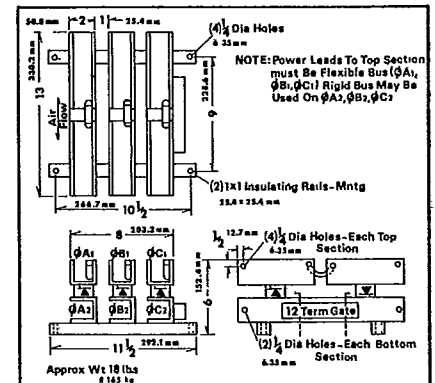

TYPE 22 WMA-, WLA-

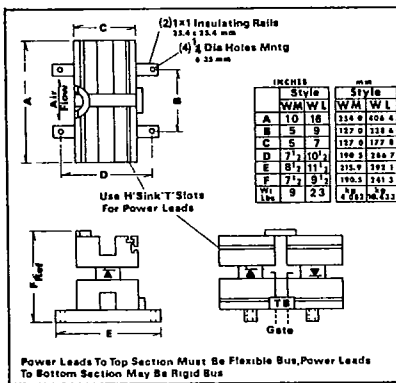

TYPE 62 WMB-, WLB-

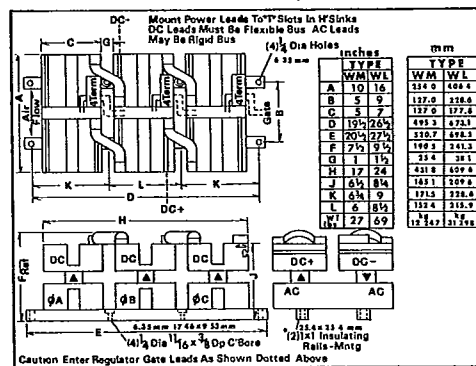

TYPE 62 WMA-, 62 WLA-

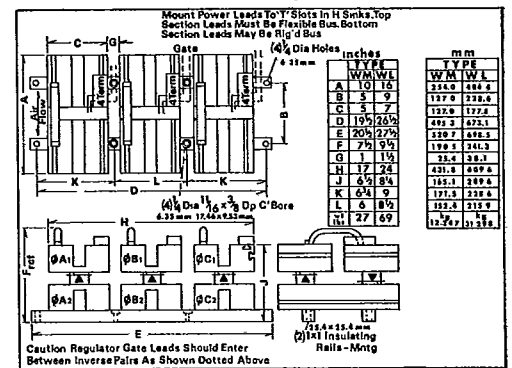

TYPE 22 RLA-

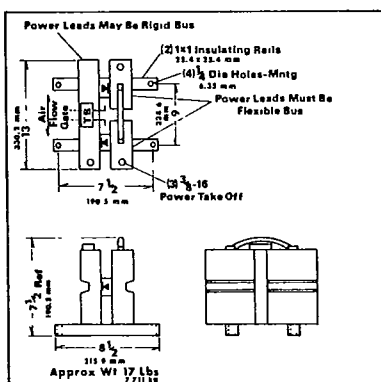

TYPE 62 RLB-

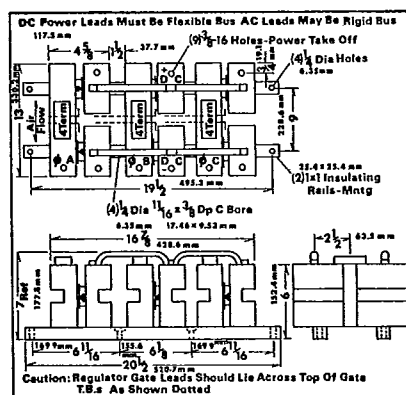

TYPE 62 RLA-

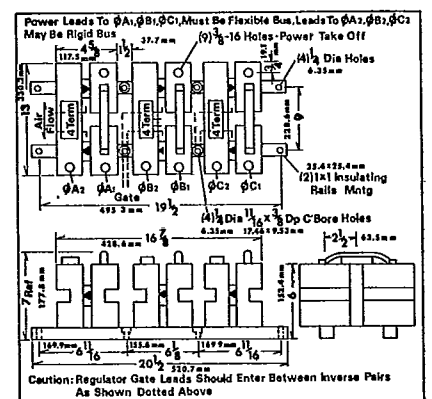

TYPE XM

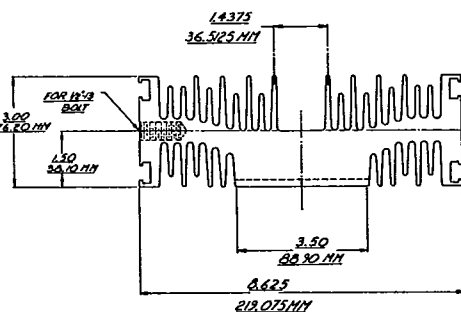

TYPE AS

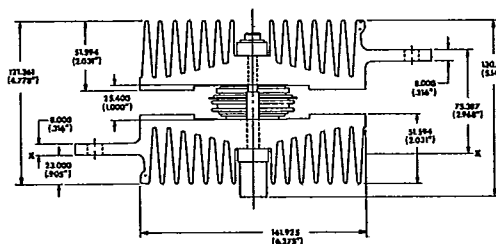

Type AS extrusion is furnished in 6" (152mm) lengths, type XM is available in 6", 8" (203mm) and 12" (305mm) lengths.

1 Ø and 3 Ø AC SWITCH THYRISTOR POWER ASSEMBLY
 WATER COOLED HS TYPE HEATSINK
 (Two in Series with Water Flow, 180° Conduction)

T-25-01

25° C WATER		DEVICE TYPE	MAX. VOLT. RATING	35° C WATER	
22 HSA— or 62 HSA—				22 HSA— or 62 HSA—	
.06 l/s 1.0 GPM	.12 l/s 2.0 GPM			.06 l/s 1.0 GPM	.12 l/s 2.0 GPM
420	440	F 180	3000	380	410
480	500	F 220	2600	440	470
590	630	F 300	2000	550	580
730	750	F 400	1800	670	700
790	840	F 500	1800	730	770
870	920	F 600	1000	810	850
590	630	G 300	3000	550	580
720	760	G 400	2600	670	710
830	890	G 500	2000	770	820
950	1010	G 650	1800	890	940
1040	1110	G 850	1800	960	1030
1150	1220	G 950	1600	1060	1120
1210	1350	Z 800	3000	1120	1260
1410	1570	Z 1000	2600	1300	1450
1700	1880	Z 1200	2000	1560	1740
2000	2220	Z 1400	1800	1850	2060
2240	2500	Z 1600	1400	2070	2310
2530	2810	Z 1800	600	2340	2600
2720	3030	Z 2000	600	2510	2800
3210	3550	Z 2300	400	3020	3340

WATER COOLED HEATSINKS	NO. IN SERIES with WATER FLOW	.03 l/s .5 GPM	.06 l/s 1.0 GPM	.09 l/s 1.5 GPM	.12 l/s 2.0 GPM
11 HS	1	.03	.02	.015	.01
22 HS	2	.04	.03	.025	.02
33 HS	3	.05	.04	.035	.03

T-01-01
T-25-01

3 Ø DC BRIDGE THYRISTOR POWER ASSEMBLY
WATER COOLED HS TYPE HEATSINK
(Two in Series with Water Flow, 120° Conduction)

25° C WATER 62 HSB -		DEVICE TYPE	MAX. VOLT. RATING	35° C WATER 62 HSB -	
.06 l/s 1.0 GPM	.12 l/s 2.0 GPM			.06 l/s 1.0 GPM	.12 l/s 2.0 GPM
570	600	F 180	3000	510	550
650	680	F 220	2600	600	630
800	850	F 300	2000	740	780
980	1020	F 400	1800	910	950
1070	1130	F 500	1800	980	1040
1180	1240	F 600	1000	1090	1150
800	850	G 300	3000	740	780
970	1030	G 400	2600	910	960
1120	1200	G 500	2000	1040	1110
1290	1370	G 650	1800	1200	1270
1410	1500	G 850	1800	1300	1390
1550	1650	G 950	1600	1430	1520
1640	1830	Z 800	3000	1520	1700
1900	2120	Z 1000	2600	1760	1960
2290	2540	Z 1200	2000	2110	2350
2700	3000	Z 1400	1800	2500	2780
3030	3380	Z 1600	1400	2800	3120
3420	3800	Z 1800	600	3160	3520
3680	4090	Z 2000	600	3400	3790
4340	4800	Z 2300	400	4080	4520

T-01-01
T-25-01

6 Ø STAR AND DOUBLE WYE WITH INTERPHASE
TRANSFORMER THYRISTOR POWER ASSEMBLY
WATER COOLED 6 Ø STAR 62 HSS- (60° Conduction)
WATER COOLED DOUBLE WYE 62 HSW- (120° Conduction)
(Two in Series with Water Flow)

25° C WATER				DEVICE TYPE	MAX. VOLT. RATING	35° C WATER			
6 Ø STAR		DOUBLE WYE				6 Ø STAR		DOUBLE WYE	
.06 l/s 1.0 GPM	.12 l/s 2.0 GPM	.06 l/s 1.0 GPM	.12 l/s 2.0 GPM			.06 l/s 1.0 GPM	.12 l/s 2.0 GPM	.06 l/s 1.0 GPM	.12 l/s 2.0 GPM
880	920	1140	1200	F 180	3000	810	850	1020	1100
1000	1050	1300	1360	F 220	2600	920	960	1200	1260
1220	1260	1600	1700	F 300	2000	1130	1180	1480	1560
1450	1510	1960	2040	F 400	1800	1360	1400	1820	1900
1650	1720	2140	2260	F 500	1800	1520	1590	1960	2080
1800	1870	2360	2480	F 600	1000	1660	1730	2180	2300
1220	1280	1600	1700	G 300	3000	1130	1210	1480	1560
1490	1580	1940	2060	G 400	2600	1390	1460	1820	1920
1750	1850	2240	2400	G 500	2000	1620	1720	2080	2220
2010	2120	2580	2740	G 650	1800	1880	1980	2400	2540
2210	2200	2820	3000	G 850	1800	2050	2170	2600	2780
2440	2570	3100	3300	G 950	1600	2260	2400	2860	3040
2630	2900	3280	3660	Z 800	3000	2450	2690	3040	3400
3090	3410	3800	4240	Z 1000	2600	2860	3160	3520	3920
3680	4040	4580	5080	Z 1200	2000	3410	3760	4220	4700
4330	4760	5400	6000	Z 1400	1800	4020	4420	5000	5560
4870	5360	6060	6760	Z 1600	1400	4520	4970	5600	6240
5450	5980	6840	7600	Z 1800	600	5060	5570	6320	7040
5840	6390	7360	8180	Z 2000	600	5440	5960	6800	7580
6760	7380	8680	9600	Z 2300	400	6400	7000	8160	9040

T-01-01
T-25-01

**3 Ø DC BRIDGE DIODE POWER ASSEMBLY
WATER COOLED HS TYPE HEATSINK
(Two in Series with Water Flow, 120° Conduction)**

25°C WATER		DEVICE TYPE	MAX VOLT RATING	35°C WATER	
62HSB--				62HSB--	
.06 l/s 1.0 GPM	.12 l/s 2.0 GPM			.06 l/s 1.0 GPM	.12 l/s 2.0 GPM
1120	1180	FD 600	3000	1060	1110
2070	2180	FD 900	2000	1980	2080
1720	1830	GD 800	2000	1620	1720
3020	3230	GD 1400	2000	2880	3070
2980	3310	ZD 1500	3000	2800	3120
4390	4910	ZD 2100	2000	4110	4600
5450	6080	ZD 2500	1200	5190	5800
6150	6870	ZD 3000	600	5850	6540

**6 Ø STAR AND DOUBLE WYE WITH INTERPHASE
TRANSFORMER DIODE POWER ASSEMBLY
6 Ø STAR 62HSS--(60° Conduction) and DOUBLE WYE 62HSW--(120° Conduction)
(Two in Series with Water Flow)**

25°C WATER				DEVICE TYPE	MAX VOLT RATING	35°C WATER			
6 Ø STAR		DOUBLE WYE				6 Ø STAR		DOUBLE WYE	
.06 l/s 1.0 GPM	.12 l/s 2.0 GPM	.06 l/s 1.0 GPM	.12 l/s 2.0 GPM			.06 l/s 1.0 GPM	.12 l/s 2.0 GPM	.06 l/s 1.0 GPM	.12 l/s 2.0 GPM
1680	1760	2240	2360	FD 600	3000	1580	1650	2120	2220
3120	3240	4140	4360	FD 900	2000	3000	3110	3960	4160
2600	2730	3440	3660	GD 800	3000	2470	2600	3240	3440
4850	5140	6040	6460	GD 1400	2000	4640	4920	5760	6140
4730	5180	5960	6620	ZD 1500	3000	4460	4900	5600	6240
7240	8010	8780	9820	ZD 2100	2000	6800	7530	8220	9200
8870	9790	10900	12160	ZD 2500	1200	8480	9360	10380	11600
10080	11150	12300	13740	ZD 3000	600	9630	10650	11700	13080

T-01-01
T25-01

TYPE HS LIQUID COOLED POWER PACKAGES



Single Cell
11HS

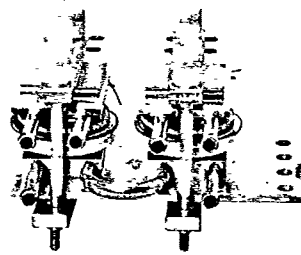

Double Cell
22HS

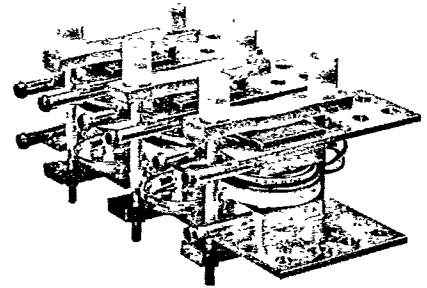

Triple Cell
33HS

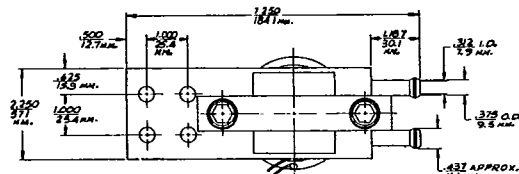

Single Cell

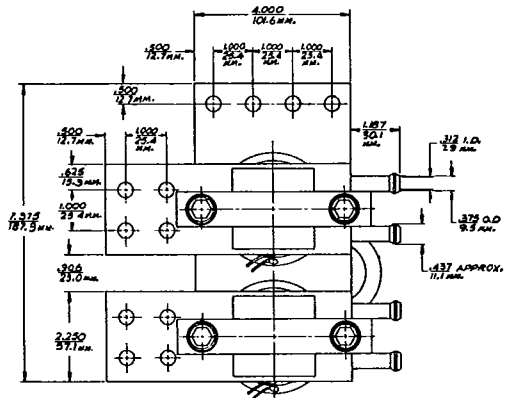
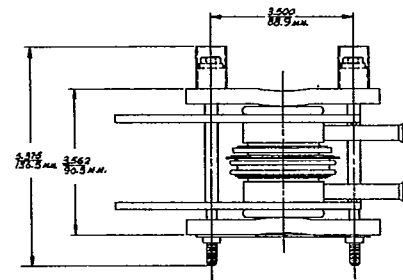

Double Cell

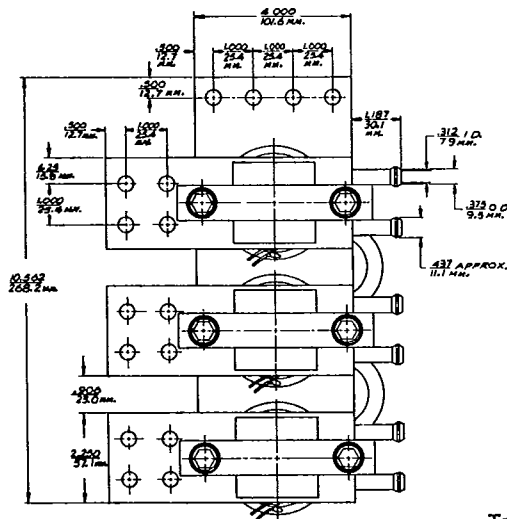
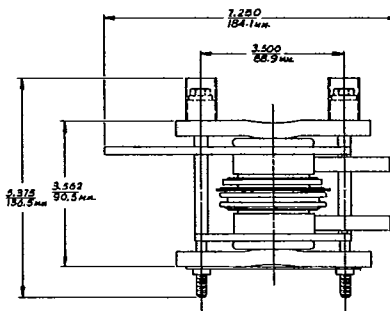

Triple Cell

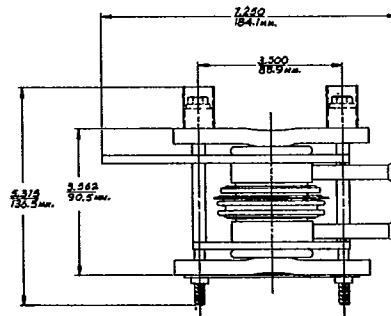

MOUNTING

The HS type heatsinks are generally mounted by bolting one terminal to a bus, with the other terminal(s) connected by means of flexible straps.

If flexible connections are made to both terminals the HS heatsink can be supported by stand off insulators threaded for the 1/4-20" clamp bolts.

T-01-01
T-25-01

"Fast Access" Power Packages

Another example of P S I leadership is the introduction of a complete line of "Fast Access" heatsinks and mounting hardware.

This equipment makes possible inspection and/or replacement of a thyristor or diode in less than a minute. Several types are available. The V.I.P. package (FIG. A) features a complete assembly, with or without cabinet for either D C bridge or A C switch service.

A more flexible arrangement is shown in FIG. B whereby universal mounting feet are added to several types of heatsinks (RL, WM and WL). These mounting feet are bolted to various electrical and mechanical mounting accessories and can be easily removed.

Standoff insulators can be used or extruded insulating channel with or without a complete bus system as shown in FIG. C. The advantage of this system is simplicity of design, low cost and low tooling cost should you care to make your own.

Note that the feet themselves add 1 3/4" (44.5mm.) length to each end, while the extruded insulating channel or bus system adds another 1 3/4" (44.5mm.) to each end for a total of 7" (178mm.) overall.

If integral fans are desired, another 2" (51 mm) is added for each. The two fan system shown in (FIG. B) is particularly popular for reliability considerations, as the assembly is sized to operate with just one fan functioning.

Fast access has proven to be a most effective selling tool for the progressive control manufacturer, particularly when used with the new "fuseless" design philosophies so popular in drives and electro-chemical supplies.

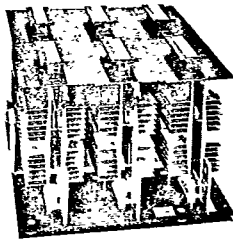

FIG. A

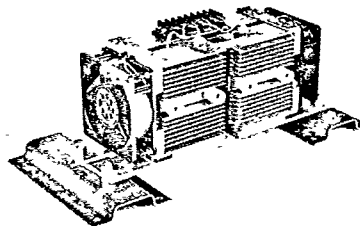

FIG. B

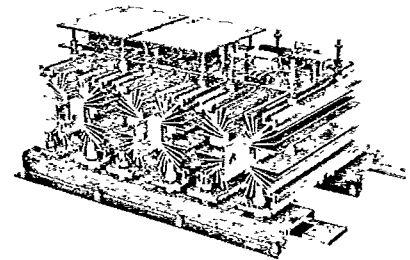

FIG. C

The Type "AS" Astrosink

Shown in FIG. D the ASTROSINK is a specialized shape used primarily for upgrading of a very popular European semiconductor. Originally designed for 28 mm and 33 mm wafers, the ASTROSINK can now accommodate the 52 mm ASTROPACK and thus offer present users the chance to upgrade their design for more surge capability, continuous current or both.

While only slightly better than the RL type heatsink in terms of thermal efficiency the ASTROSINK has also gained acceptance as a sturdy work horse on which pressure mounted or stud type semiconductors can be mounted, with the convenient mounting tabs offering simple connection to buswork. Available in 6" lengths as standard the thermal impedance figures are given in FIG. E.

Convert-a-Pack

While the industry has rapidly switched from stud to pressure mounted semiconductors, many customers wish to upgrade existing controls using stud type heatsinks to take advantage of pressure mount without a major redesign.

The P S I Convert-a-Pack answers this need (FIG. F), with special mounting hardware and auxiliary heatsinks fitting inside of existing extrusions and bus connections. Each Convert-a-Pack is specifically designed by P.S.I. for individual objectives. They offer the control manufacturer the fastest method of enjoying most of the advantages of pressure mounted units.

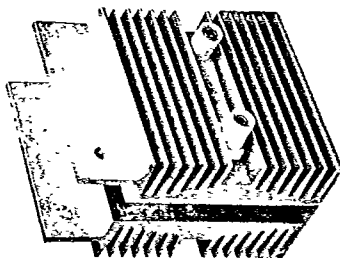

FIG. D

AIR VELOCITY		θ HS-AMB.
2.5m/sec	500 LFM	.12°C/Watt
5.0m/sec	1000 LFM	.08
7.5m/sec	1500 LFM	.06
10.0m/sec	2000 LFM	.05

For a pair of ASTROSINKS
149 mm. (5.87")

FIG. E

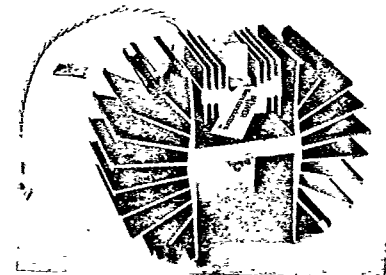
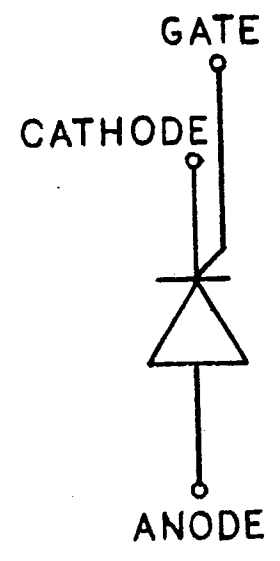
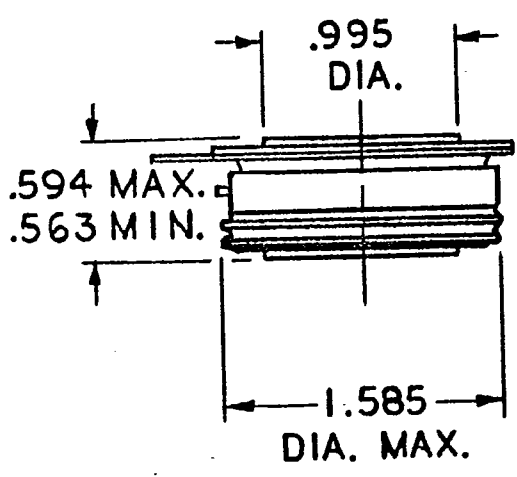
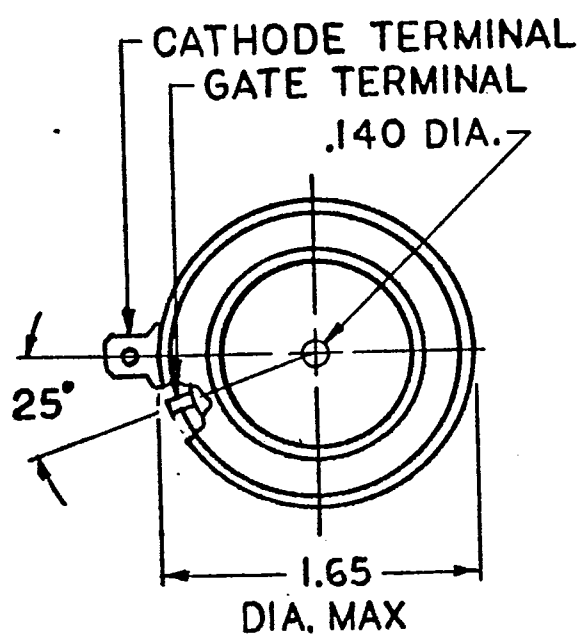

FIG. F

T-91-20



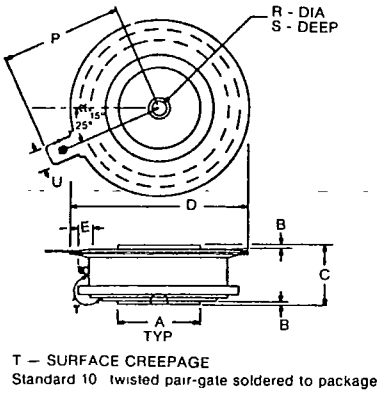

FIG. 1

TABLE OF DIMENSIONS
Conversion Table

SYM	DECIMAL INCHES		METRIC MM	
	MIN	MAX	MIN	MAX
A	.744	.752	18.897	19.101
B	.030	.060	.762	1.524
C	.515	.565	13.081	14.351
D	1.600	1.656	40.64	42.06
E	.110	—	2.794	—
P	1.090	1.125	27.69	28.55
R	.135	.145	3.429	3.683
S	.067	.083	1.701	2.108
T	.340	—	8.636	—
U	.186	.189	4.724	4.801

OUTLINE DRAWINGS

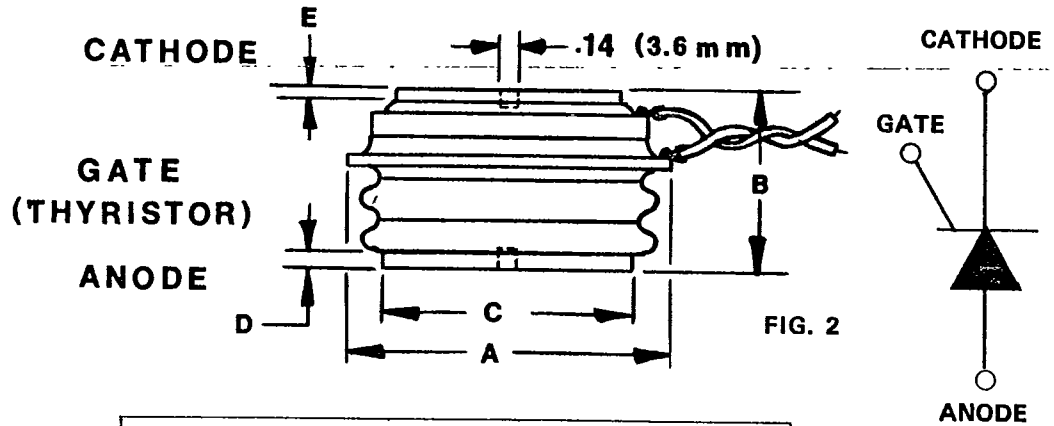

FIG. 2

SYM	FIG. 2				
	E, ED- Power Pack	F, FD- Power Pack	G, GD- Mega Pack	H, HH-HD- Astro Pack	J-JD J-Pack
A	1.73 (44)	1.73 (44)	1.93 (49)	2.75 (70)	4.80 (122)
B	.625 (16)	.97 (25)	.97 (25)	.97 (25)	1.38 (35.0)
C	1.14 (29)	1.00 (25.4)	1.25 (32)	1.75 (44.5)	3.0 (76.2)
D	.025 (.6)	.08 (2.0)	.08 (2.0)	.07 (1.8)	.14 (3.5)
E	.025 (.6)	.11 (2.8)	.12 (3.05)	.07 (1.8)	.14 (3.5)

Note: Thyristors have gate and aux. cathode leads of #18 stranded wire, 10" (255mm) length standard.

JEDEC Outline TO-48

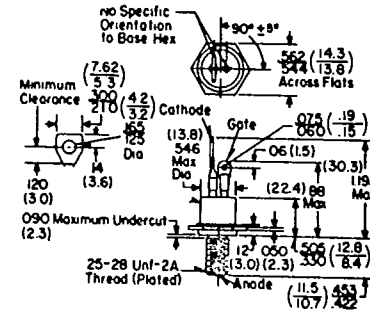

FIG. 6

JEDEC Outline TO-94

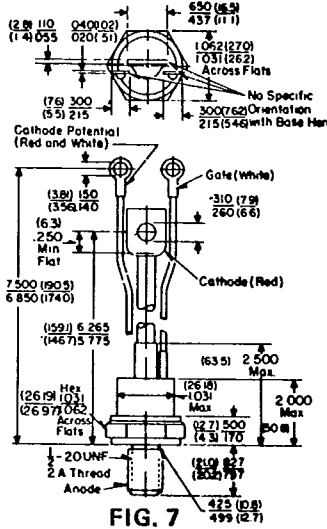

FIG. 7

JEDEC Outline TO-93

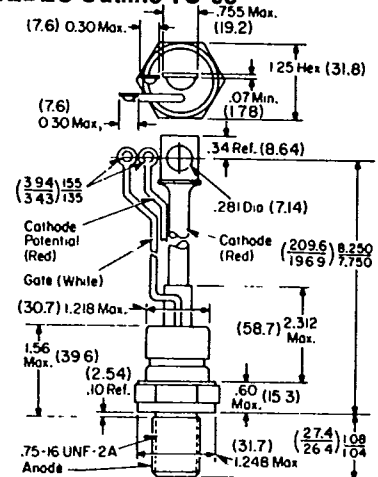

FIG. 8

JEDEC Outline DO-5

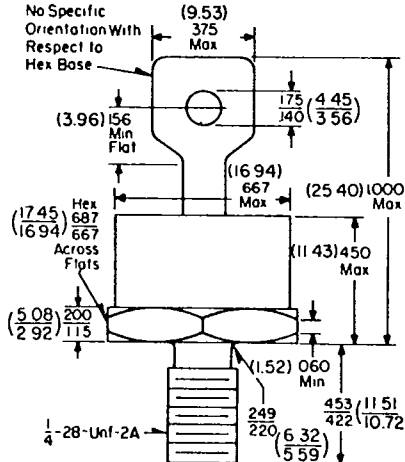

FIG. 9

JEDEC Outline DO-8

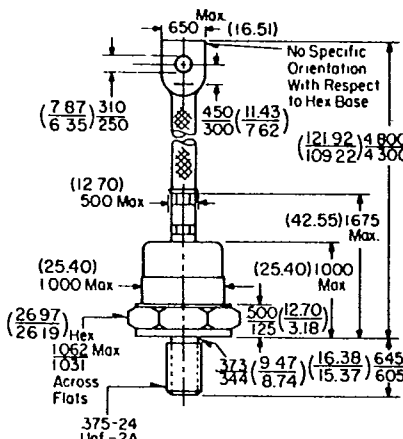

FIG. 10

JEDEC Outline DO-9

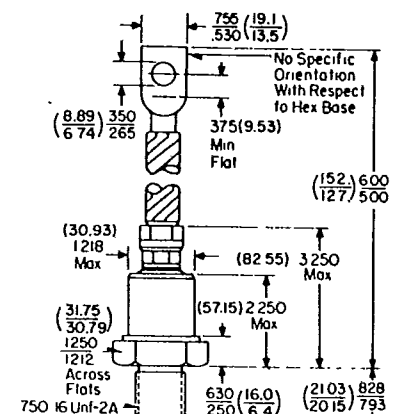

FIG. 11

MOUNTING INSTRUCTIONS

The contact faces of the heat sink should be kept clean and should be flat to within .001"/" T.I.R. The contact pedestals of the POWER PACK should be treated carefully as they are copper and easily damaged. We recommend the use of Penetrox "A" available from Burndy Corporation as heat sink compound. For proper use of this material, contact the factory.

Assembly drawings of the PSI clamps are shown below. The force applied to the heat sinks is controlled by the number of turns made on the bolts. The bolts are first tightened "finger" tight (10 inch-lbs.) using a torque indicating device.

The drawings show the number of turns and the tightening sequence for a range of forces between 500 kg. (1,100 lb.) and 2000 kg. (4,400 lb.) This method of assembly will insure that the force applied to the device will be within ± 20% of the specified value and that the thermal impedance (junction to heat sink) will not exceed the value specified on the spec. sheets of the individual devices. Bolts should be tightened in quarter turn increments.

The J-Pack clamp tightening sequence is 5 ft-lbs. followed by 1-1/4 turns. See Figure on page 19.

ASSEMBLY ORDER

1. Bolt
2. Two steel washers
3. Aluminum washer
4. Insulator
5. Aluminum washer
6. One Spring Bar
7. Heat sinks and device
8. One Spring Bar
9. Nut Holder

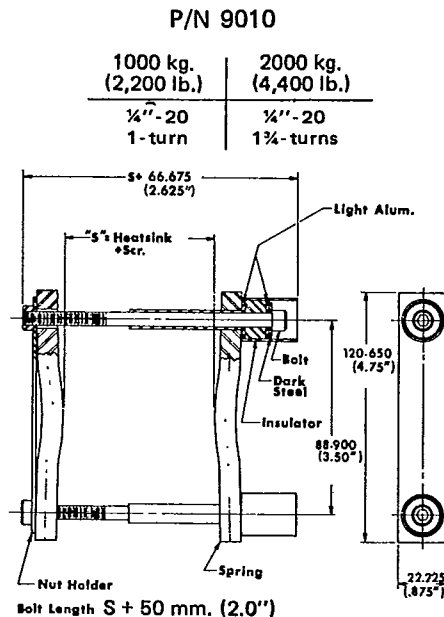
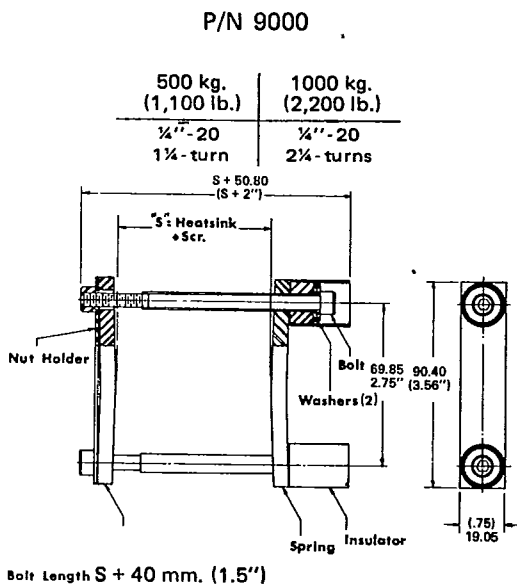

THESE ARE TEMPLATES FOR THE MOST POPULAR SIZES OF SCR'S. JUST PLACE YOUR PART ON THE TEMPLATE AND IDENTIFY WHICH SERIES YOU HAVE. WITH THIS INFORMATION PLUS THE VOLTAGE AND HORSEPOWER RATING OF THE SYSTEM IN WHICH IT IS INSTALLED. WE CAN THEN DO A CROSS REFERENCE.

T-91-20

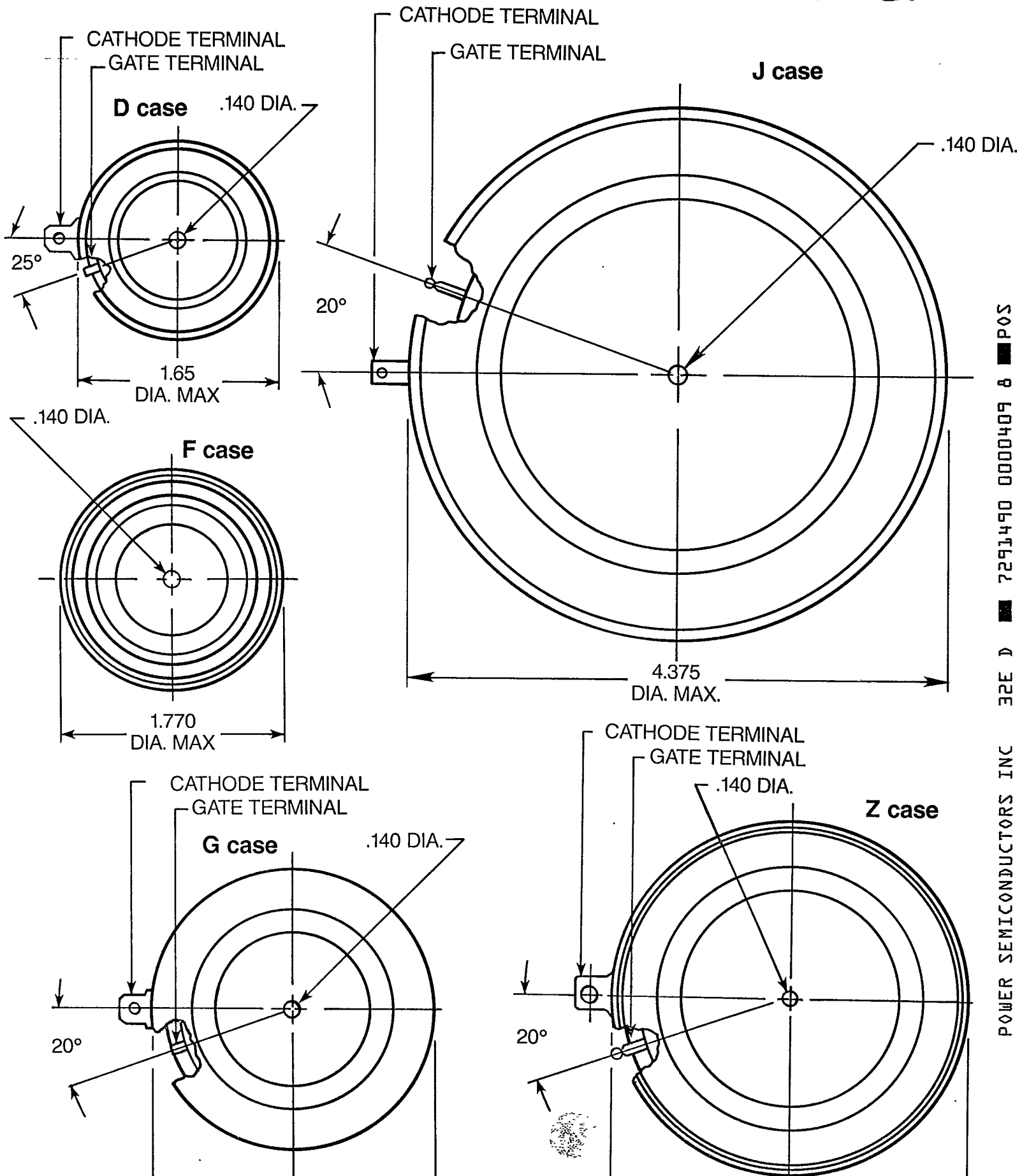

POWER SEMICONDUCTORS INC 32E D 7291490 0000409 & POS